



[www.violetlighting.com](http://www.violetlighting.com)



浙江省慈溪市慈东滨海区金海路885号 NO.885 Jinhai Rd, Binhai Zone, Cidong, Cixi, Zhejiang, China  
PC : 315338 TEL : 0086-574-5899 9996 FAX : 0086-574-5899 9889 Email : [marketing@violetlighting.com](mailto:marketing@violetlighting.com)



专注·共赢·志在超越 Focus, Win and Beyond  
IP65防水灯, 办公灯具, 电器制造商  
IP65 Waterproof Lighting, Office Lighting, Lighting Electronics



# CATALOGUE

LED Light





Office Building

## About us

Ningbo Violet Lighting Electric Co., Ltd. locates in the beautiful and affluent eastern China, East-Cixi Industrial Zone, where is convenient in land, sea and air transportation. The company has been well reputed as a professional producer of IP65 waterproof LED lights, fluorescent lights and lighting electronics, integrates product designing, developing, manufacturing and sales.

**NINGBO VIOLET LIGHTING ELECTRIC CO.,LTD is Philips Lighting strategic supplier in Great China Region for more than 15 years, offering the total lighting solutions including LED board and LED drivers for Waterproof batten and Panel families. Violet is growing up together with Philips to stay in the lead in lighting industry and offer the best solutions for customers!**

Adhering to the guidelines of "dedication, win-win and pursuit of excellence", Violet has built up its core strengths through decades efforts. The company is well organized and managed through ERP system, supported by a modernized workshop of 60,000 square meters, a comfortable staff dormitory, an R&D and technical team of over 50 people, an experienced management team, a TUV Reinland TMPL laboratory and a full set of processing equipments including tooling, injection moulding, punching, spray coating, SMT, AI, led-free soldering and aging. It has fully passed ISO9001:2008, ISO14001:2004, OHSAS18001:2007 and SA8000:2008 system certification. All products have passed CE, GS, BS, UL, VDE and CCC approvals. It has obtained over 40 patents and has been awarded as a National High-tech Enterprise.



Injection Molding Workshop

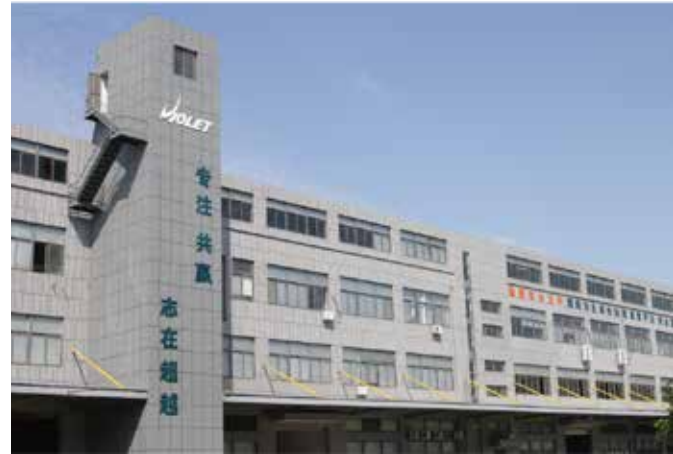

Production Workshop



Reception Desk



Show Room

Violet remains good faith by improving service, strengthening management, and constantly innovating. Based on high quality & high specialty, Violet has won the domestic and foreign customers' praise and recognition. Its products have been exported to Europe, North America, South America, Africa, the Middle East and Southeast Asia.

To pursue excellent quality and comfortable lighting is our ultimate goal. Hope to cooperate with you sincerely, to join hands in creating a bright future!





# Laboratory Instruments & Equipments



Integrating Sphere



IES Light Intensity Tester



Dustproof test box



MAX.1.5m cold and hot impact test box



Glow wire test box



Temperature and humidity cycle test box



ROHS Tester



Salt spray anti-corrosion test box



Electrostatic discharge generator



High and low temperature test box



Needle flame test instrument



Ultraviolet weather resistance test box



IP testing chamber



X-ray tester



# Laboratory Instruments & Equipments



Auto SMTSM421



Vertical AI 6360B



Horizontal 6241BAI



Plug-in Molding Chamber



Manual Plug-in Line



SMTLine



# Production Equipment



Rust-proof Phosphating



Auto Spray Production Line



Manual Punching



Press Brake



High Speed CNC Auto-punching



Injection Moulding

# Contents

## Waterproof LED light

---

### Whole-seal series



VE-GH / 01



VE-GF / 02



VE-GF02 / 03



VE-X1 / 04



VE-GI / 05

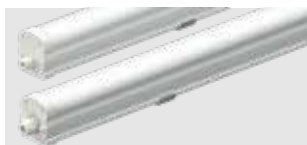

VE-GB/GB03 / 06



VE-GM / 07



VE-GM02 / 08

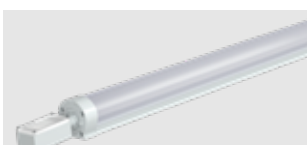

VE-GM-M/MD / 09

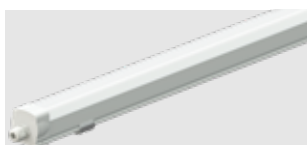

VE-GS / 11



VE-GE02 / 12

### Clips-free series



VE-SA / 13



VE-SB / 14

### Aluminium housing series

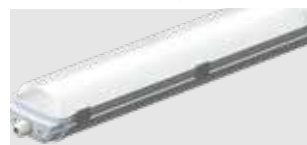

VE-FA / 15

### LED Light traditional housing



VE-SC / 16



VE-SE / 17



VE-N / 19



T8-DS / 20



VWP-LC001 / 21



T8-D / 22



T8-G / 23

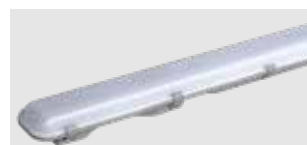

T8-DN / 24



VLOE-T / 25



T5-B / 26



T5-C / 27

---

### Whole-seal series



VE-DL-S / 28



VE-DL-SU / 29



DB-TO / 30



VE-DB-02 / 31

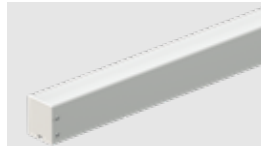

VE-DC / 32

---

### Bulkhead



VC-PL / 33



VC112E / 34



VC-FA/FB / 35



VC-FG / 36

---

### LED Panel Light

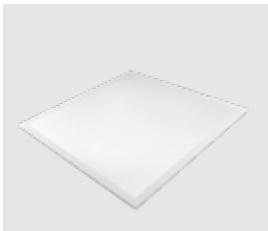

VDP-PL / 37

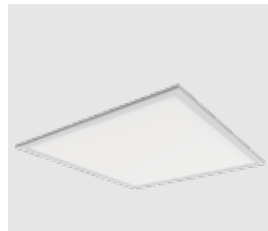

VE-EMP/EM / 38

### Highbay



CFL001 / 39



CFL001P / 40

---

### Horticulture Light (HL)



GM-HL / 41



GI-HL / 43



HL-T / 44

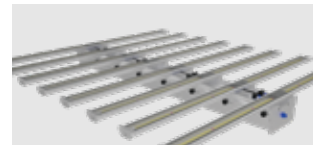

HL-01V / 45

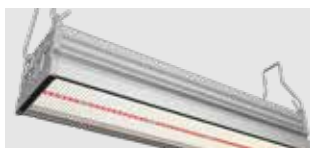

HL-02V-600 / 47



HL-02V-1200 / 48



HL-04V / 49

---

### Waterproof connectors



VE24A / 51

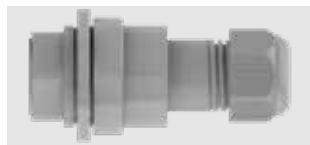

VE24B / 52

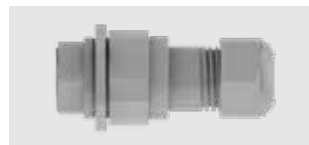

VE24C / 52



# Application places



Office

Underground parking garage



Tunnel

Warehouse





**Workshop**

**Pharmaceutical  
industry**



**Assembly line**

**Food shop**





# Application places



**Office**

**Meeting room**



**Corridor**





**Shops**



**Station hall**



**Sitting room**

# VE-GH IP65 Waterproof LED light

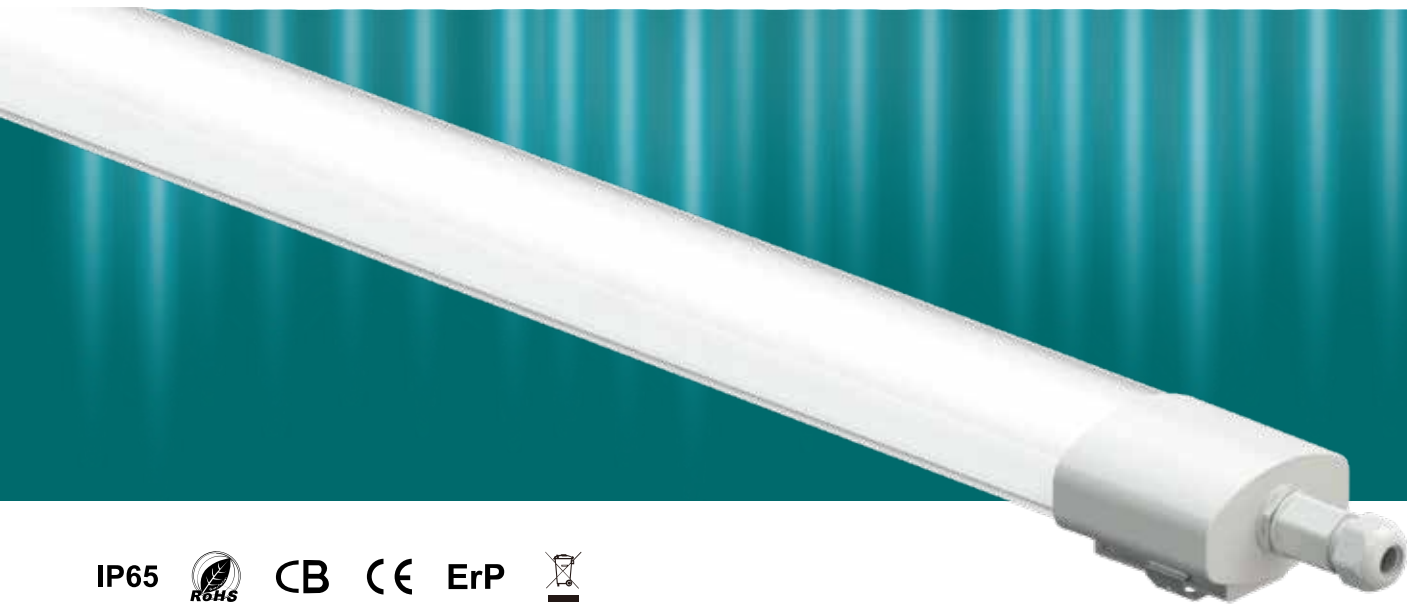

## General characteristics:

1. An IP65 waterproof LED light;
2. Integrates PC cover with light diffusing agent and colored PC housing;
3. Housing caps solidly bonded with housing by our innovative joint-melt technology;
4. The rotating structure of connector is easy for wiring.
5. No clips, no gaskets.

## Applications recommendation:

Can be applied in wet interior, dusty place and outdoor places such as Cellars, Sheds, Plant rooms, Warehouses, Open and closed parking areas, Workstations, Corridors etc

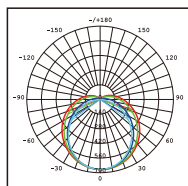

VE112GH Photometric

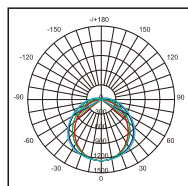

VE115GH Photometric

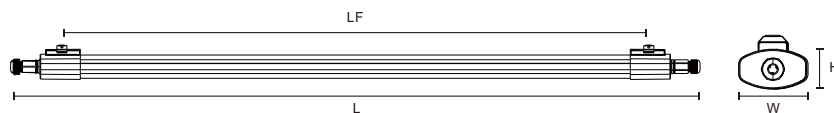

Type	Power	Luminous	CCT	Dimensions(L×W×H×LF)	Q'ty/ctn	Packing size
VE112GH	36W	5200lm	4000K	1260×80×55×1065mm	12PCS	1330×270×250mm
VE115GH	42W	6000lm	4000K	1560×80×55×1365mm	9PCS	1630×270×195mm

Attention: The lumen tolerance is ± 10%.

# VE-GF IP65 Waterproof LED light



## General characteristics:

1. Durable design: protection grade is up to IP65 and IK08, use clips to connect body and diffuser
2. Easy installation: screw, brackets and the others accessories in put into the light
3. Two optional diffuser( DS: matte + stripes cover BS: prism+ stripes cover)
4. Economical and practical: through optimum design for the size, lights has highlight efficiency
5. Uniform luminance.
6. SDCM  $\leq 5$ , CRI  $> 80$
7. 110LM/W (standard version), 115LM/W ( updated version); other parameter requirements need to be customized
8. Lifespan: 30000hrs
9. ambient temperature:  $-20 \sim +40^{\circ}\text{C}$

## Applications recommendation:

Supermarket, shopping mall, dining room, school, Hospital, parking lot, warehouse, corridor etc.

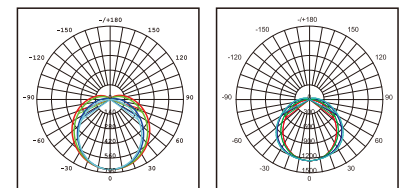
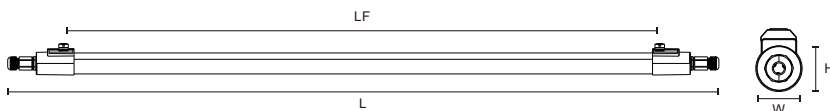

VE112GF Photometric

VE115GF Photometric

Type	Power	Luminous	CCT	Dimensions(L×W×H)	Q'ty/ctn	Packing size
VE112GF	18W	2600lm	4000K	1280×43×50x1080mm	15PCS	1350×250×180mm
VE115GF	23W	3300lm	4000K	1570×43×50x1370mm	15PCS	1640×250×180mm

Attention: The lumen tolerance is  $\pm 10\%$ .



# VE-GF02 IP66 Waterproof LED light

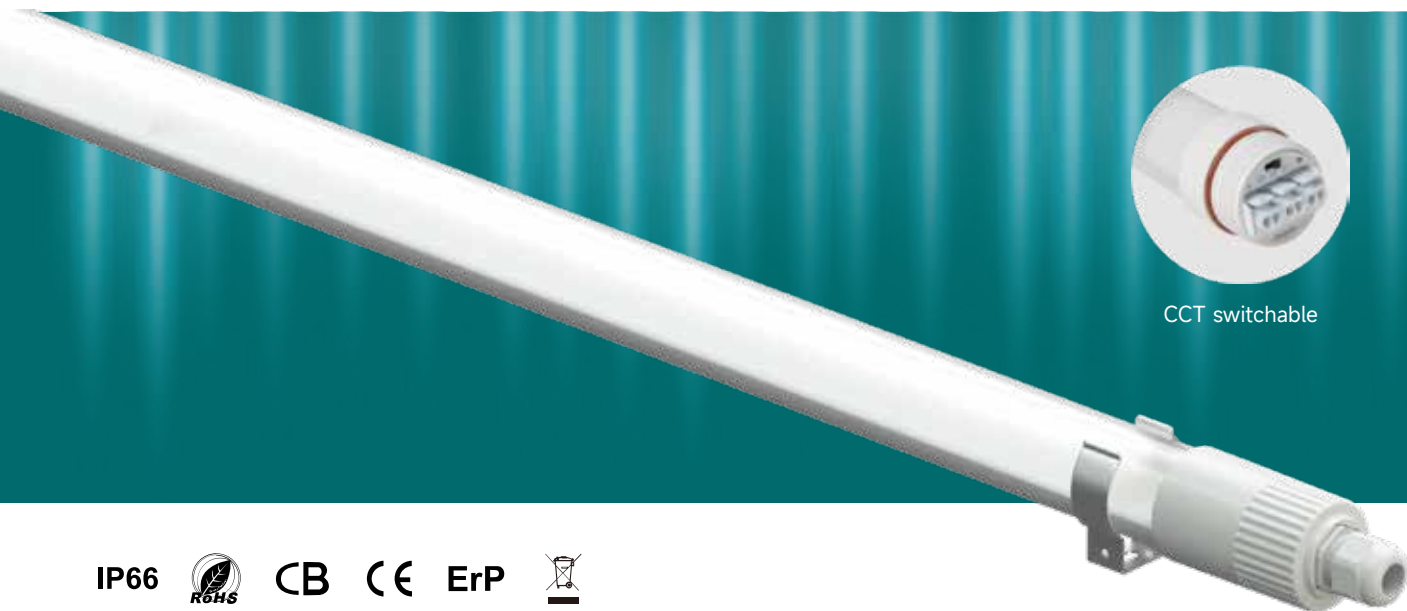

IP66  CB  ErP 

## General characteristics:

1. An IP66 waterproof LED light;
2. Integrates PC cover with light diffusing agent and colored PC housing;
3. Housing caps solidly bonded with housing by our innovative joint-melt technology;
4. The rotating structure of connector is easy for wiring.
5. No clips, no gaskets.

## Applications recommendation:

Can be applied in wet interior, dusty place and outdoor places such as Cellars, Sheds, Plant rooms, Warehouses, Open and closed parking areas, Workstations, Corridors etc

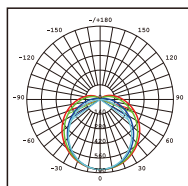

VE112GF02 Photometric

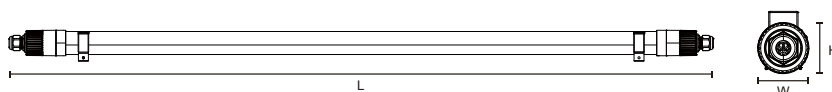

Type	Power	Luminous	CCT	Dimensions(L×W×H×LF)	Q'ty/ctn	Packing size
VE112GF02-20D83065	20W	3000lm	3000K/4500K/6500K	1200×43×43mm	36PCS	1250×310×315mm
VE112GF02-20D84065	20W	3000lm	4000K/5200K/6500K	1200×43×43mm	36PCS	1250×310×315mm
VE112GF02-20830	20W	3000lm	3000K	1200×43×43mm	36PCS	1250×310×315mm
VE112GF02-20840	20W	3000lm	4000K	1200×43×43mm	36PCS	1250×310×315mm
VE112GF02-20865	20W	3000lm	6500K	1200×43×43mm	36PCS	1250×310×315mm

Attention: The lumen tolerance is ± 10%.

# VE-X1 IP69K Waterproof LED light

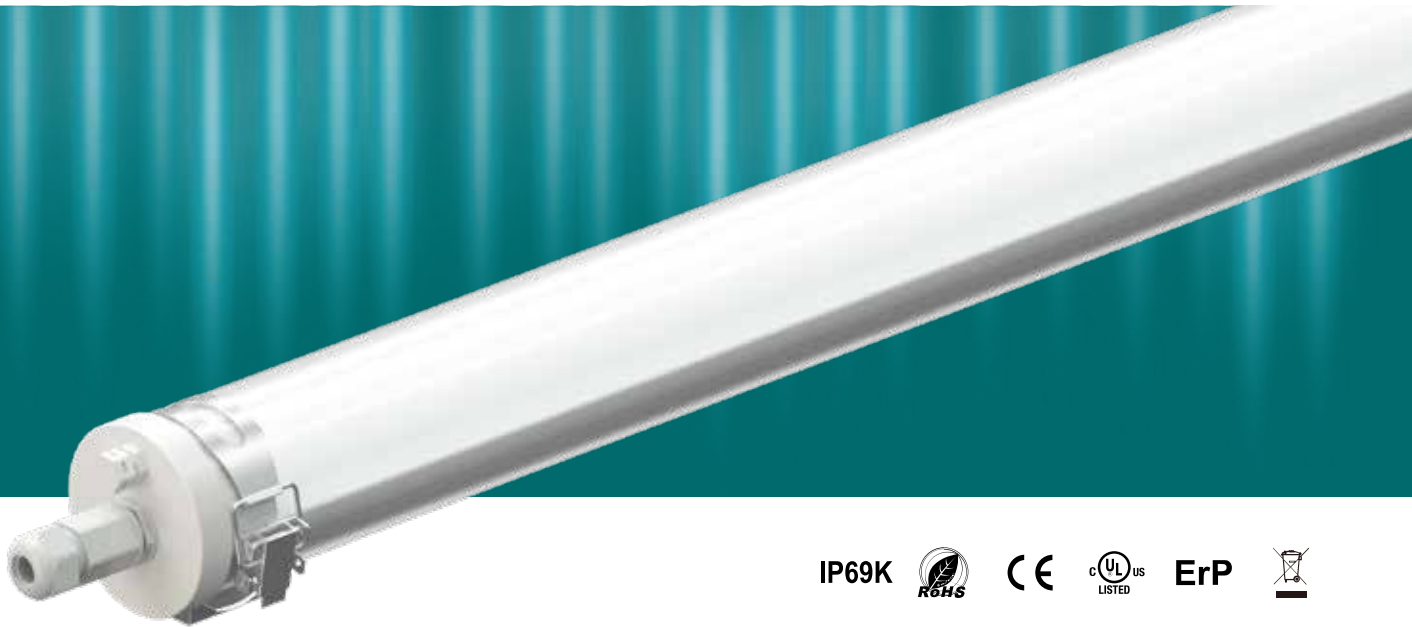

## General characteristics:

1. An IP69K waterproof LED light;
2. Integrates cover with light diffusing agent and colored PMMA housing;
3. Housing and caps are sealed by hot melting;
4. Violet-Patented waterproof instant coupler eases external wiring, no need to open the housing or housing cap;
5. No clips.

## Applications recommendation:

Can be applied in wet interior, dusty place and outdoor places such as Cellars, Sheds, Plant rooms, Warehouses, Open and closed parking areas, Workstations, Corridors etc.

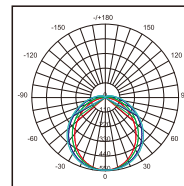
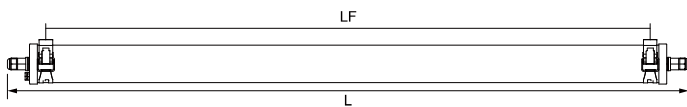

VE106X1 Photometric

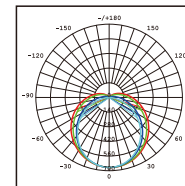

VE112X1 Photometric

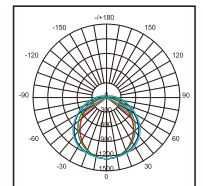

VE115X1 Photometric

Type	Power	Luminous	CCT	Dimensions(L×W×H)	Q'ty/ctn	Packing size
VE106X1	18W	2430lm	4000K	686×74×74×532mm	12PCS	716×323×251mm
VE112X1	36W	5040lm	4000K	1281×74×74×1122mm	9PCS	1313×246×251mm
VE115X1	48W	6720lm	4000K	1581×74×74×1422mm	6PCS	1613×246×174mm

Attention: The lumen tolerance is ± 10%.



# VE-GI IP65 Waterproof LED light



## General characteristics:

1. An IP65 waterproof LED light;
2. Integrates PC cover with light diffusing agent and colored PC housing;
3. Housing caps solidly bonded with housing by our innovative joint-melt technology;
4. Violet-Patented waterproof instant coupler eases external wiring, no need to open the housing or housing cap;
5. Multiple installation methods by cap brackets or rotatable housing bottom bracket, which improves convenience during external wiring.
6. No clips, no gaskets.

## Applications recommendation:

Can be applied in wet interior, dusty place and outdoor places such as Cellars, Sheds, Plant rooms, Warehouses, Open and closed parking areas, Workstations, Corridors etc

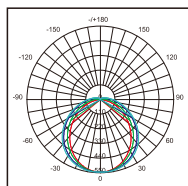

VE106GI Photometric

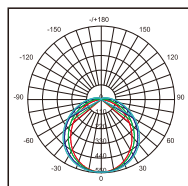

VE112GI Photometric

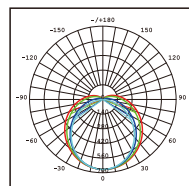

VE115GI Photometric

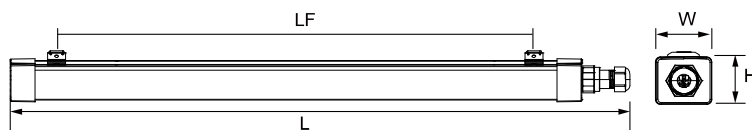

Type	Power	Luminous	CCT	Dimensions(L×W×H×LF)	Q'ty/ctn	Packing size
VE106GI	14.5W	1890lm	4000K	645×53×46mm	20PCS	729×242×269mm
VE112GI	28W	3640lm	4000K	1214×53×46mm	15PCS	1289×185×269mm
VE115GI	44W	5720lm	4000K	1494×53×46mm	15PCS	1569×185×269mm
VE106GI-TW1	14.5W	1890lm	4000K	707×53×46mm	20PCS	782×242×269mm
VE112GI-TW1	28W	3640lm	4000K	1267×53×46mm	15PCS	1342×185×269mm
VE115GI-TW1	44W	5720lm	4000K	1547×53×46mm	15PCS	1622×185×269mm

Attention: The lumen tolerance is ± 10%.

# VE-GB IP65 Waterproof LED light



## General characteristics:

1. An IP65 waterproof LED light;
2. Integrates PC cover with light diffusing agent and colored PC housing;
3. Housing caps sealed by silicon rubber gasket;
4. Drawer type junction box (our patent) eases external wiring;
5. No clips.

## Applications recommendation:

Can be applied in wet interior, dusty place and outdoor places such as Cellars, Sheds, Plant rooms, Warehouses, Open and closed parking areas, Workstations, Corridors etc.

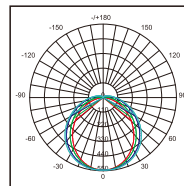
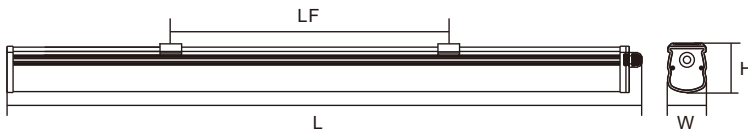

VE106GB Photometric

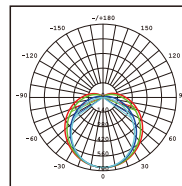

VE112GB Photometric

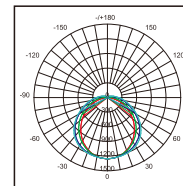

VE115GB Photometric

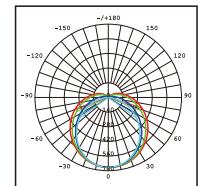

VE112GB-UL Photometric

Type	Power	Luminous	CCT	Dimensions(L×W×H)	Q'ty/ctn	Packing size
VE106GB	18W	2430lm	3000K/4000K/6500K	656×64×76×300mm	12PCS	745×300×260mm
VE112GB	36W	4860lm	3000K/4000K/6500K	1256×64×76×600mm	12PCS	1345×300×260mm
VE115GB	48W	6480lm	3000K/4000K/6500K	1556×64×76×750mm	9PCS	1645×230×260mm
VE112GB-UL	36W	4860lm	4000K/6500K	1256×64×76×600mm	12PCS	1345×300×260mm
VE106GB-03	19W	2570lm	3000K/4000K/6500K	615×63×75×300mm	12PCS	692×300×260mm
VE112GB-03	35W	4730lm	3000K/4000K/6500K	1175×63×75×600mm	12PCS	1257×300×260mm
VE115GB-03	50W	6750lm	3000K/4000K/6500K	1456×63×75×750mm	9PCS	1532×230×260mm

Attention: The lumen tolerance is ± 10%.

# VE-GM IP65 Waterproof LED light



IP65  CB  ErP 

## General characteristics:

1. An IP65 waterproof LED light;
2. Integrates PC cover with light diffusing agent and colored PC housing;
3. Housing caps solidly bonded with housing by our innovative joint-melt technology;
4. The rotating structure of connector is easy for wiring.
5. No clips

## Applications recommendation:

Can be applied in wet interior, dusty place and outdoor places such as Cellars, Sheds, Plant rooms, Warehouses, Open and closed parking areas, Workstations, Corridors etc

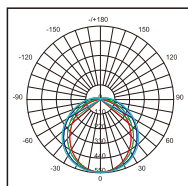

VE106GM Photometric

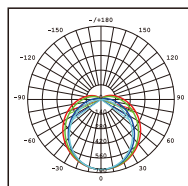

VE112GM Photometric

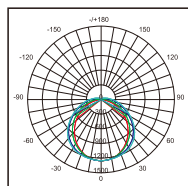

VE115GM Photometric



Type	Power	Luminous	CCT	Dimensions(L×W×H×LF)	Q'ty/ctn	Packing size
VE106GM	20W	2600lm	4000K	606×70×69×300mm	12PCS	646×327×242mm
VE112GM	36W	4600lm	4000K	1167×70×69×600mm	12PCS	1207×327×242mm
VE115GM	50W	6500lm	4000K	1448×70×69×750mm	9PCS	1488×249×242mm

Attention: The lumen tolerance is ± 10%.

# VE-GM02 IP65 Waterproof LED light



## General characteristics:

1. An IP65 waterproof LED light;
2. Integrates PC cover with light diffusing agent and colored PC housing;
3. Housing caps solidly bonded with housing by our innovative joint-melt technology;
4. The rotating structure of connector is easy for wiring.
5. No clips

## Applications recommendation:

Can be applied in wet interior, dusty place and outdoor places such as Cellars, Sheds, Plant

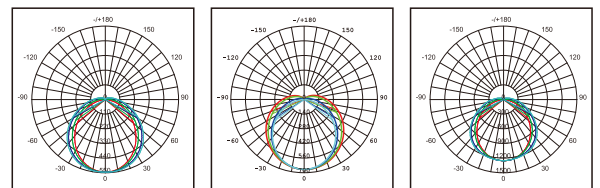
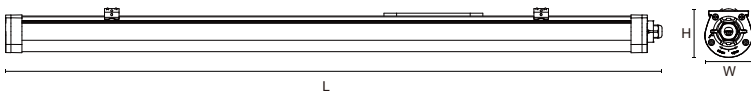

VE106GM02 Photometric VE112M02 Photometric VE115M02 Photometric

Type	Power	Luminous	CCT	Dimensions(L×W×H)	Q'ty/ctn	Packing size
VE106GM02	19W	2500lm	4000K	606×70×69×300mm	12PCS	646×327×242mm
VE112GM02	19W	2500lm	4000K	1167×70×69×600mm	12PCS	1207×327×242mm
VE112GM02	35W	4600lm	4000K	1167×70×69×600mm	12PCS	1207×327×242mm
VE115GM02	28W	3800lm	4000K	1448×70×69×750mm	9PCS	1488×249×242mm
VE115GM02	53W	7200lm	4000K	1448×70×69×750mm	9PCS	1488×249×242mm

Attention: The lumen tolerance is ± 10%.

# VE-GM02-M/MD IP65 Waterproof LED light

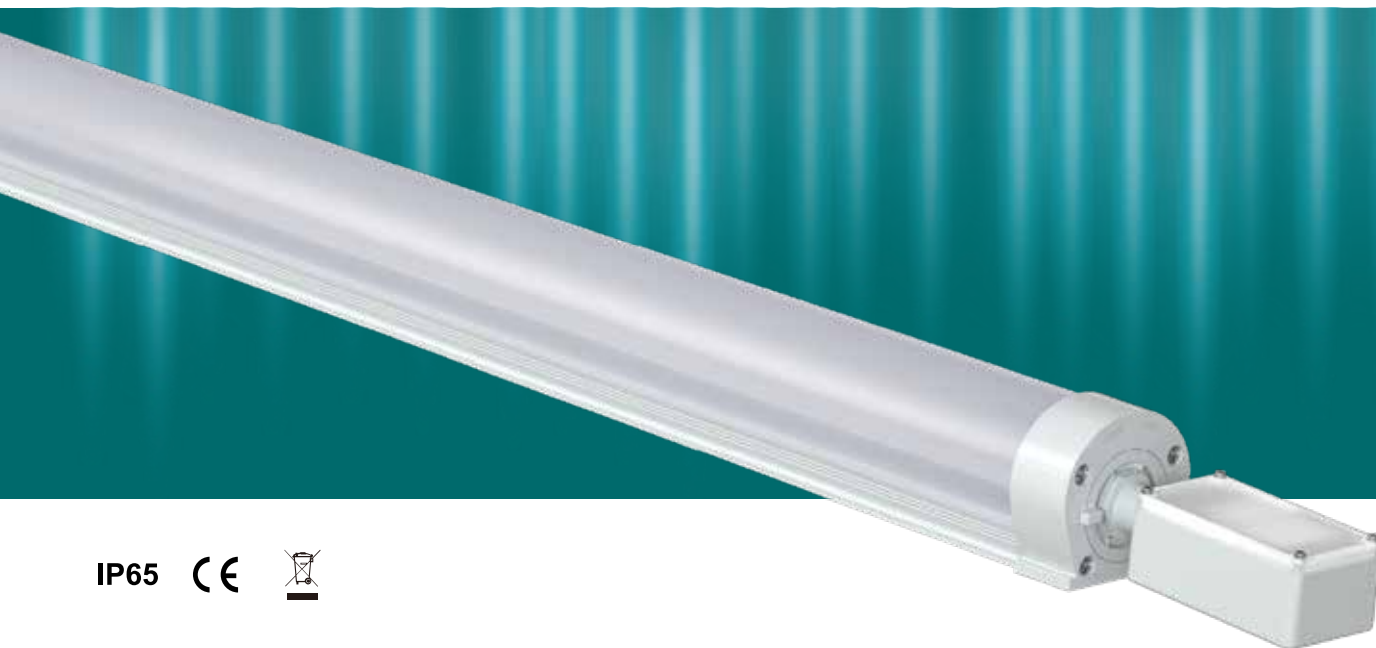

IP65 CE 

## General characteristics:

1. An IP65 waterproof LED light;
2. Integrates PC cover with light diffusing agent and colored PC housing;
3. Housing caps solidly bonded with housing by our innovative joint-melt technology;
4. The rotating structure of connector is easy for wiring.
5. No clips

## Applications recommendation:

Can be applied in wet interior, dusty place and outdoor places such as Cellars, Sheds, Plant rooms, Warehouses, Open and closed parking areas, Workstations, Corridors etc

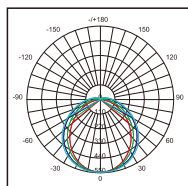

VE112GM02-M Photometric

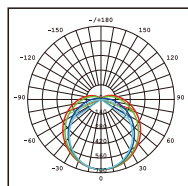

VE112GM02-MD Photometric

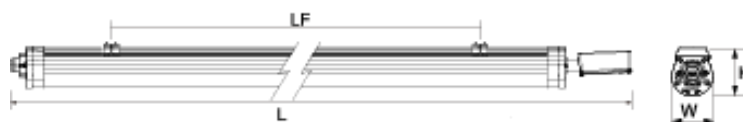

Type	Power	Luminous	CCT	Dimensions(L×W×H×LF)	Q'ty/ctn	Packing size
VE112GM02-M	18W	2600lm	4000K	1295×70×69mm	12PCS	1315×236×244mm
VE112GM02-MD	18W	2600lm	4000K	1295×70×69mm	12PCS	1315×236×244mm
VE112GM02-M	35W	4600lm	4000K	1295×70×69mm	12PCS	1315×236×244mm
VE112GM02-MD	35W	4600lm	4000K	1295×70×69mm	12PCS	1315×236×244mm
VE115GM02-M	53W	7200lm	4000K	1576×70×69mm	12PCS	1595×236×244mm
VE115GM02-MD	53W	7200lm	4000K	1576×70×69mm	12PCS	1595×236×244mm

Attention: The lumen tolerance is ± 10%.



# LED sensor light



On/Off Control

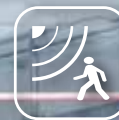

Detection Area



Daylight Sensor



Hold Time



Stand-by period



Stand-by dimming level

## Automatically ON/OFF function (VE-GM02-M/MD)

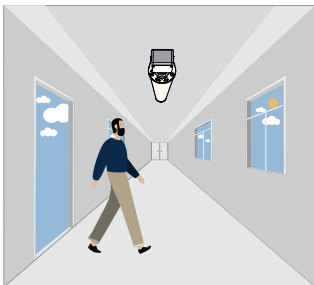

With sufficient daylight, even when motion detected, light remains OFF.



With insufficient daylight, the sensor turns light ON when motion gets detected.



The sensor turns OFF light automatically after the holdtime when there's no motion detected.

## Corridor Function, Bi-level Dimmable (VE-GB02-MD)

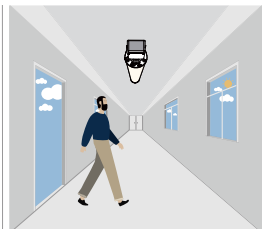

With sufficient daylight, the sensor keeps light OFF even motion gets detected.



With insufficient daylight, the sensor turns light ON when motion gets detected.

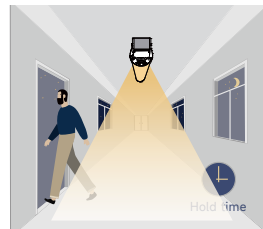

After there's no motion detected, the sensor keeps light ON 100% for holdtime.

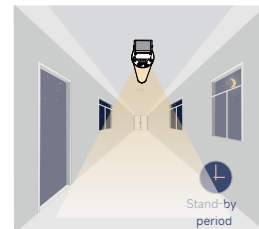

After holdtime, sensor dims light to standby dimming level for standby period.

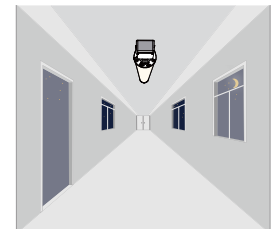

The sensor turns OFF light automatically after the standby period when there's no motion detected.



# VE-GS IP65 Waterproof LED light

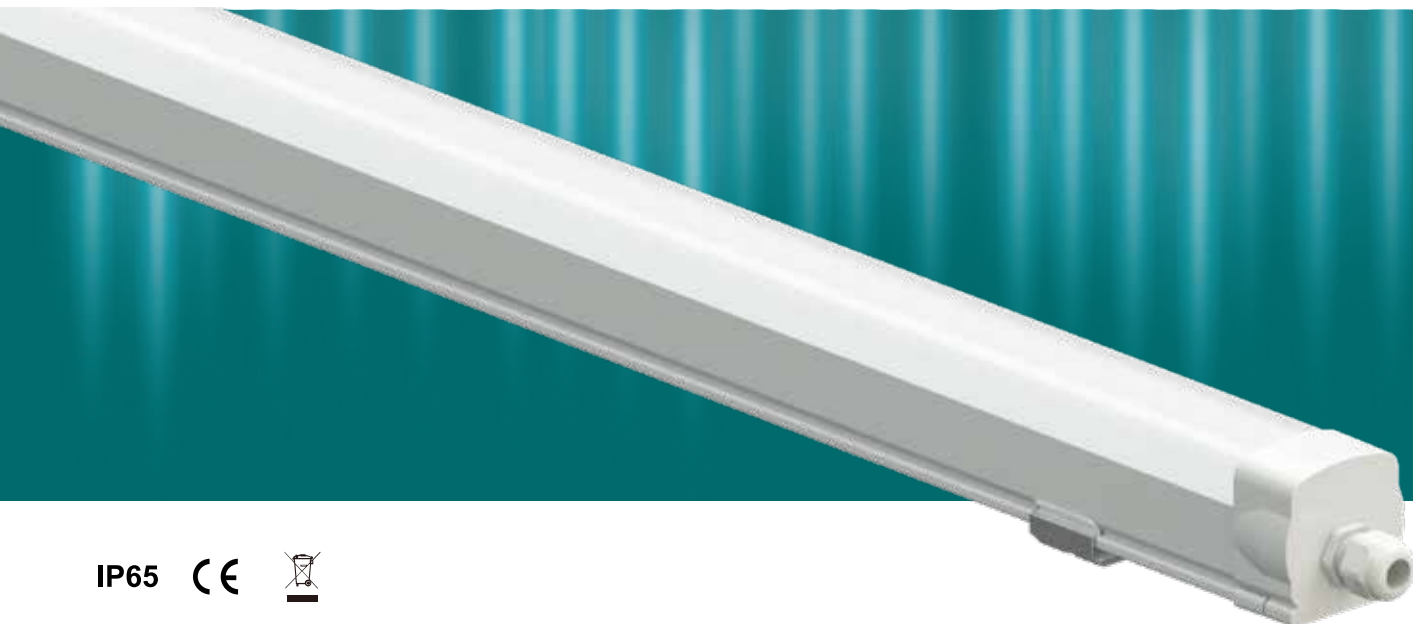

IP65 CE 

## General characteristics:

1. An IP65 waterproof LED light;
2. Integrates PC cover with light diffusing agent and colored PC housing;
3. Housing caps solidly bonded with housing by our innovative joint-melt technology;
4. The rotating structure of connector is easy for wiring.
5. No clips

## Applications recommendation:

Can be applied in wet interior, dusty place and outdoor places such as Cellars, Sheds, Plant rooms, Warehouses, Open and closed parking areas, Workstations, Corridors etc

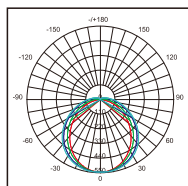

VE106GS Photometric

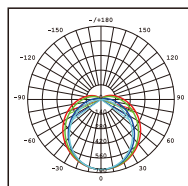

VE112GS Photometric

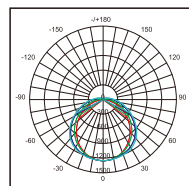

VE115GS Photometric



Type	Power	Luminous	CCT	Dimensions(L×W×H)	Q'ty/ctn	Packing size
VE106GS	18W	2350lm	4000K	605×56×63mm	12pcs	650×240×220mm
VE112GS	36W	4700lm	4000K	1205×56×63mm	12pcs	1250×240×220mm
VE115GS	48W	6300lm	4000K	1405×56×63mm	9pcs	1450×200×220mm
VE106GS-TW1	18W	2350lm	4000K	655×56×63mm	12pcs	700×240×220mm
VE112GS-TW1	36W	4700lm	4000K	1255×56×63mm	12pcs	1300×240×220mm
VE115GS-TW1	48W	6300lm	4000K	1455×56×63mm	9pcs	1500×200×220mm

Attention: The lumen tolerance is ± 10%.

# VE-GE02 IP65 Waterproof LED light



## General characteristics:

1. An IP65 waterproof LED light;
2. Integrates PC cover with light diffusing agent and colored PC housing;
3. Housing caps sealed by silicon rubber gasket;
4. Adopt male and female quick connector, making the wiring easier;
5. No clips.

## Applications recommendation:

Can be applied in wet interior, dusty place and outdoor places such as Cellars, Sheds, Plant rooms, Warehouses, Open and closed parking areas, Workstations, Corridors etc.

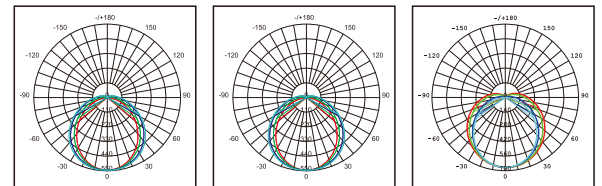
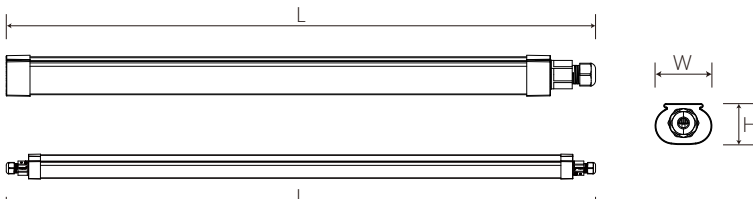

VE106GE02 Photometric    VE112GE02 Photometric    VE115GE02 Photometric

Type	Power	Luminous	CCT	Dimensions(L×W×H)	Q'ty/ctn	Packing size
VE106GE02	18W	2400lm	4000K	620×60×43mm	12PCS	650×204×204mm
VE112GE02	30W	4200lm	4000K	1180×60×43mm	12PCS	1210×204×204mm
VE115GE02	40W	5500lm	4000K	1460×60×43mm	12PCS	1490×204×204mm
VE106GE02 - TW1	18W	2400lm	4000K	675×60×52mm	12PCS	715×204×238mm
VE112GE02 - TW1	30W	4200lm	4000K	1235×60×52mm	12PCS	1265×204×238mm
VE115GE02 - TW1	40W	5500lm	4000K	1515×60×52mm	12PCS	1555×204×238mm

Attention: The lumen tolerance is ± 10%.

# VE-SA IP65 Waterproof LED light



IP65 CE 

## General characteristics:

1. An IP65 waterproof LED light;
2. Integrates PC cover with light diffusing agent and colored PC housing;
3. Housing caps solidly bonded with housing by our innovative joint-melt technology;
4. The rotating structure of connector is easy for wiring.
5. No clips

## Applications recommendation:

Can be applied in wet interior, dusty place and outdoor places such as Cellars, Sheds, Plant rooms, Warehouses, Open and closed parking areas, Workstations, Corridors etc

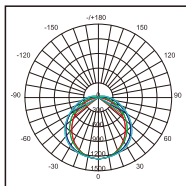

VE112SA Photometric

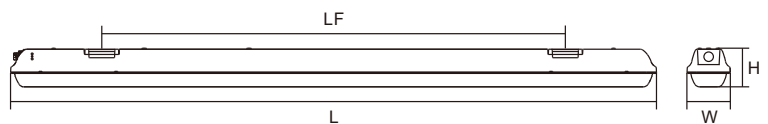

Type	Power	Luminous	CCT	Dimensions(L×W×H×LF)	Q'ty/ctn	Packing size
VE112SA	36W	3600lm	4000K/6500K	1265×80×90×600mm	9PCS	1315×285×185mm

Attention: The lumen tolerance is ± 10%.

# VE-SB IP65 Waterproof LED light

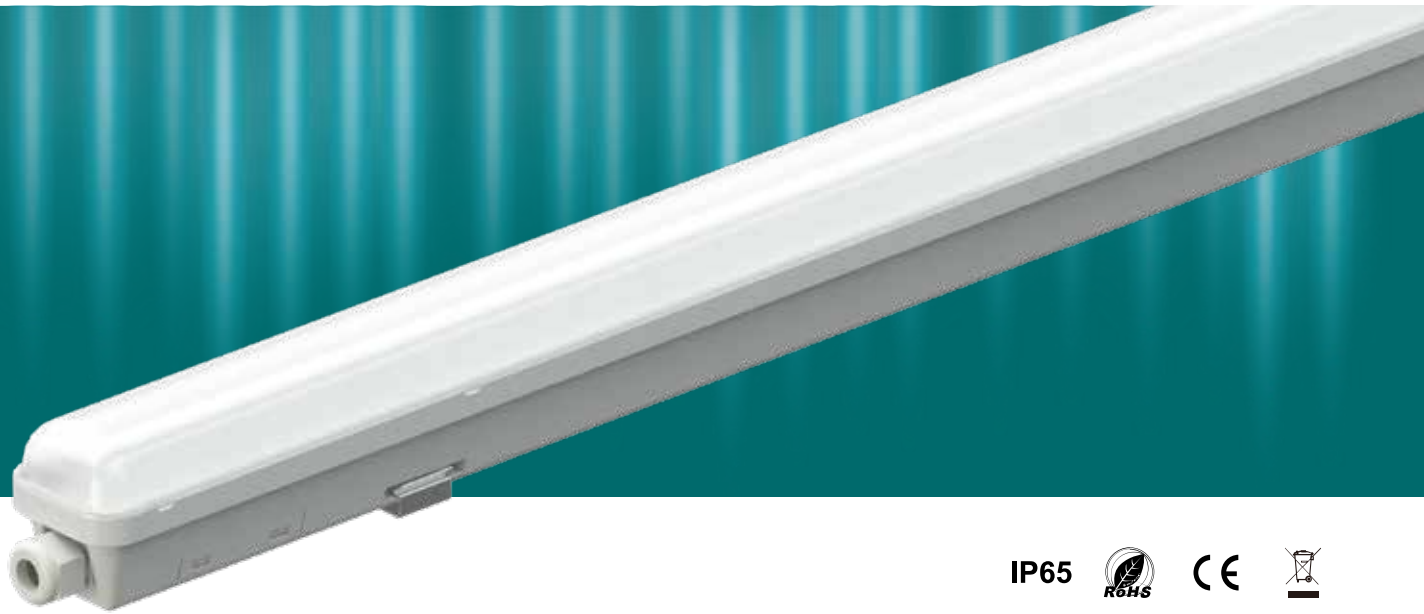

## General characteristics:

1. An IP65 waterproof LED light;
2. Integrates PC cover with light diffusing agent and colored PC housing;
3. Housing caps solidly bonded with housing by our innovative joint-melt technology;
4. The rotating structure of connector is easy for wiring.
5. No clips

## Applications recommendation:

Can be applied in wet interior, dusty place and outdoor places such as Cellars, Sheds, Plant rooms, Warehouses, Open and closed parking areas, Workstations, Corridors etc

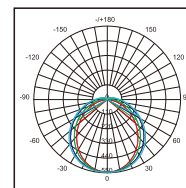

VE106SB Photometric

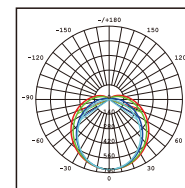

VE112SB Photometric

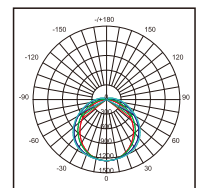

VE115SB Photometric

Type	Power	Luminous	CCT	Dimensions(L×W×H)	Q'ty/ctn	Packing size
VE106SB	18W	2160lm	4000K/6500K	650×60×57×350mm	9PCS	675×219×206mm
VE112SB	36W	4350lm	4000K/6500K	1250×60×57×900mm	6PCS	1275×219×144mm
VE115SB	48W	5800lm	4000K/6500K	1550×60×57×1200mm	6PCS	1575×219×144mm

Attention: The lumen tolerance is  $\pm 10\%$ .

# VE-FA IP65 Waterproof LED light

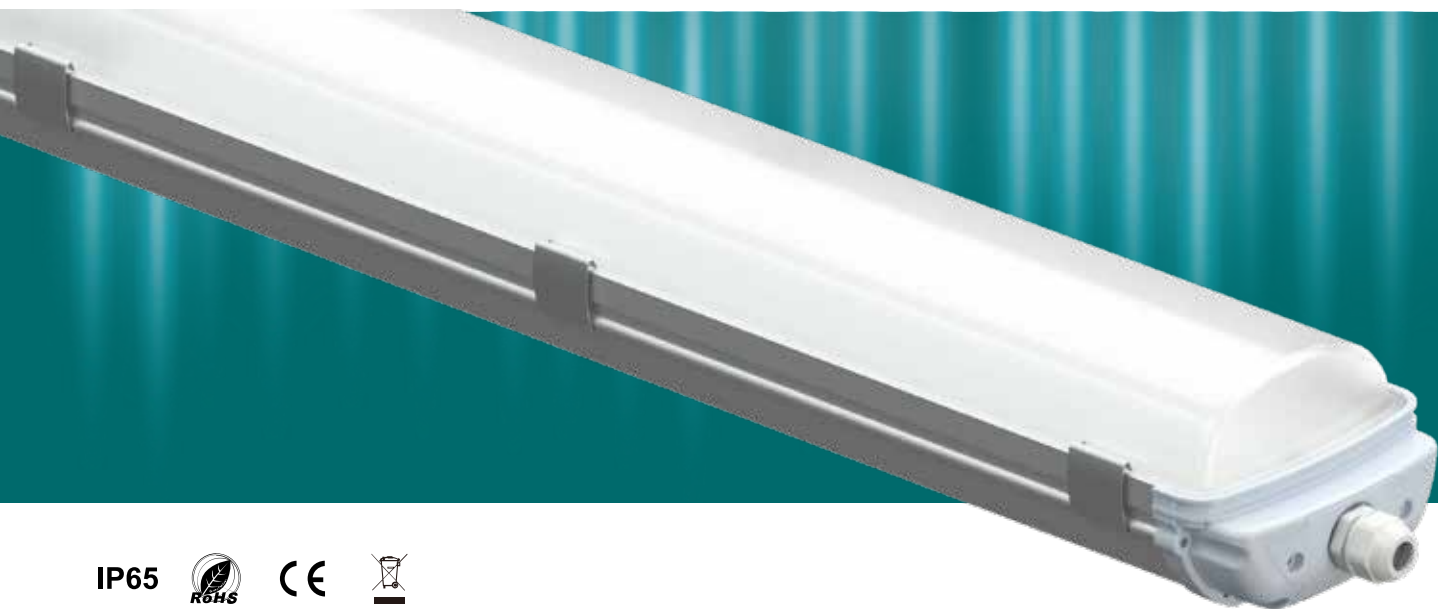

## General characteristics:

1. An IP65 waterproof LED light fixture, anode oxidation treated aluminium housing with PC caps;
2. LM-80 LED chips, lifespan > 50,000 hours, mild light, no flicker, no glare and no noise;
3. Opaque PC cover with light diffusing agent, light transmittance  $\geq 80\%$ ;
4. Sensitive microwave inductor with quick response, wide range and high stability, ignores influence of temperature, air flow, dust, ash, fogs, etc.;
5. Unique drawer type junction box (our patent) eases external wiring;
6. Stainless steel clips.

## Applications recommendation:

Can be applied in wet interior, dusty place and outdoor places such as Cellars, Sheds, Plant rooms, Warehouses, Open and closed parking areas, Workstations, Corridors etc.

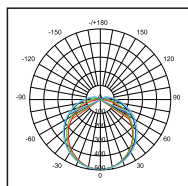

VE210FA Photometric

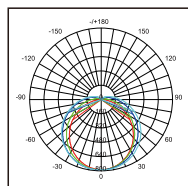

VE220FA Photometric

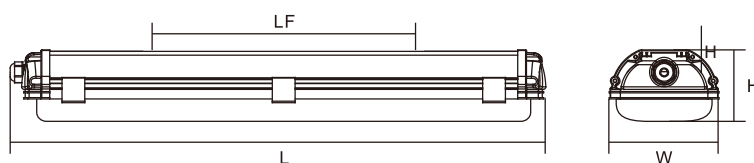

Type	Power	Luminous	CCT	Dimensions(L×W×H×LF)	Q'ty/ctn	Packing size
VE210FA	20W	1700lm	4000K/5000K/6500K	635×126×90×300mm	9PCS	650×400×324mm
VE210FAG	20W	2400lm	4000K/5000K/6500K	635×126×90×300mm	9PCS	650×400×324mm
VE220FA	40W	3000lm	4000K/5000K/6500K	1195×126×90×600mm	6PCS	1220×400×220mm
VE220FAG	40W	4800lm	4000K/5000K/6500K	1195×126×90×600mm	6PCS	1220×400×220mm

Attention: The lumen tolerance is  $\pm 10\%$ .

# VE-SC IP65 Waterproof LED light



## General characteristics:

1. An IP65 waterproof LED light;
2. Injected PC cover with light diffusing agent and gasket PC housing;
3. Housing caps sealed by silicon rubber gasket;
4. The unique quick connection structure makes the connection of wires outside and installation more easily;

## Applications recommendation:

Can be applied in wet interior, dusty place and outdoor places such as Cellars, Sheds, Plant rooms, Warehouses, Open and closed parking areas, Workstations, Corridors etc.

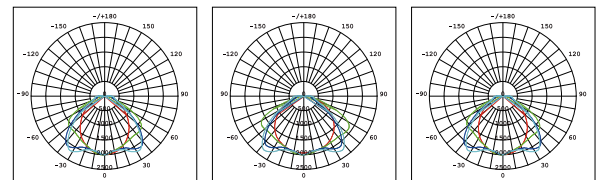
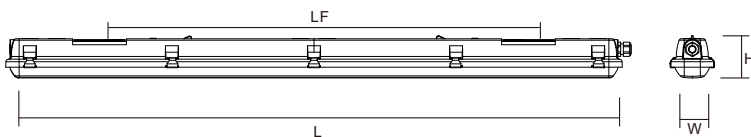

VE112SC Photometric

VE115SC Photometric

VE112SC UL Photometric

Type	Power	Luminous	CCT	Dimensions(L×W×H)	Q'ty/ctn	Packing size
VE112SCU	36W	3600lm	4000K	1170×83×73.5×800mm	6PCS	1245×351×244mm
VE112SC	36W	4000lm	4000K/6500K	1150×82×73.5×650mm	6PCS	1227×280×180mm
VE115SC	50W	6000lm	4000K/6500K	1430×82×73.5×900mm	6PCS	1507×280×180mm

Attention: The lumen tolerance is ± 10%.



# VE-SE IP66 Waterproof LED light

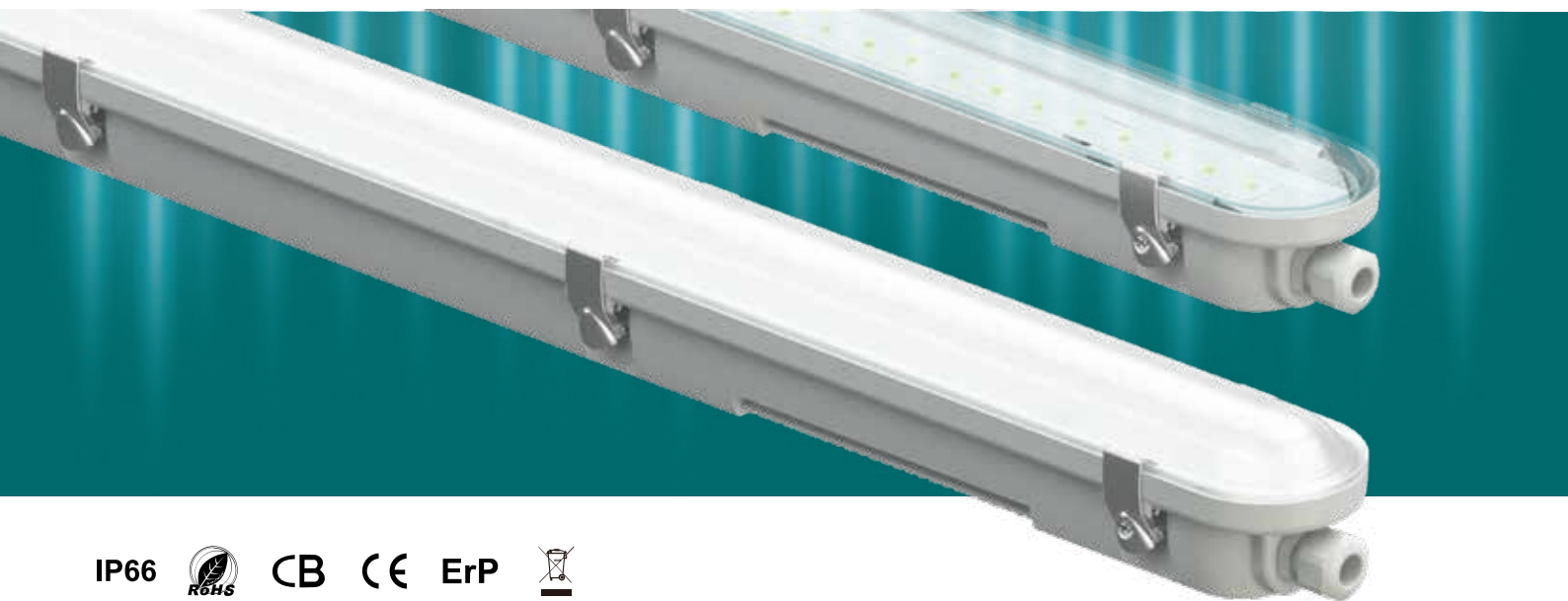

IP66  CB  ErP 

## General characteristics:

1. An IP66 waterproof LED light;
2. Injected PC cover with light diffusing agent and PC housing;
3. Housing caps sealed by silicon rubber gasket;
4. The unique quick connection structure makes the connection of wires outside and installation more easily;
5. Two kinds of cover optional.

## Applications recommendation:

Can be applied in wet interior, dusty place and outdoor places such as Cellars, Sheds, Plant rooms, Warehouses, Open and closed parking areas, Workstations, Corridors etc.

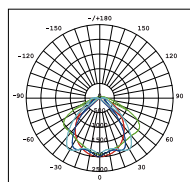

VE106SE Photometric

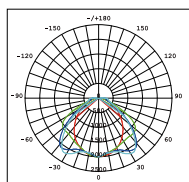

VE112SE Photometric

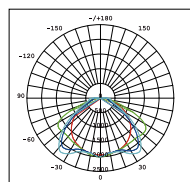

VE115SE Photometric

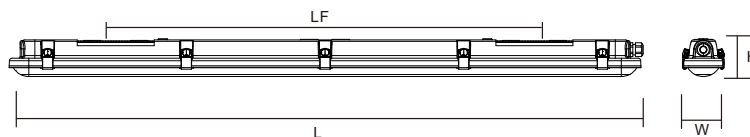

Type	Power	Luminous	CCT	Dimensions(L×W×H×LF)	Q'ty/ctn	Packing size
VE106SE	17W	2550lm	4000K	607×75×70×290mm	9PCS	658×240×263mm
VE112SE	32W	4800lm	4000K	1207×75×70×800mm	6PCS	1258×240×182mm
VE115SE	52W	7800lm	4000K	1507×75×70×1060mm	6PCS	1558×240×182mm

Attention: The lumen tolerance is ± 10%.



**Waterproof LED light**

# VE-N (GRP) IP65 Waterproof LED light



IP66



ErP



## General characteristics:

1. An IP65 waterproof LED light;
2. Injected PC cover with light diffusing agent and GRP housing;
3. Housing caps sealed by silicon rubber gasket;
4. 304 clips.

## Applications recommendation:

Can be applied in wet interior, dusty place and outdoor places such as Cellars, Plant rooms, Warehouses, chicken farm, chemical plant etc

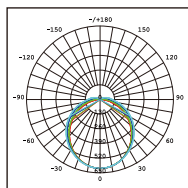

VE106N Photometric

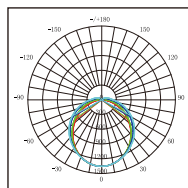

VE112N Photometric

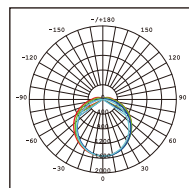

VE115N Photometric

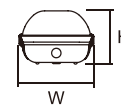
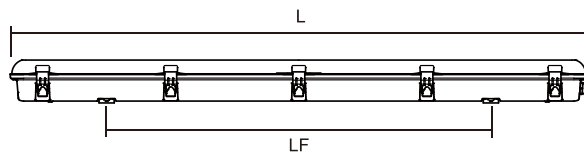

Type	Power	Luminous	CCT	Dimensions(L×W×H×LF)	Q'ty/ctn	Packing size
VE-106N	22W	2900lm	4000K/6500K	620×105×88×340mm	8PCS	630×225×385mm
VE-112N	42W	5500lm	4000K/6500K	1220×105×88×800mm	6PCS	1230×225×295mm
VE-115N	58W	7600lm	4000K/6500K	1520×105×88×1100mm	4PCS	1530×225×205mm

Attention: The lumen tolerance is ± 10%.



# T8BS/DS-LM IP65 Waterproof LED light



## General characteristics:

1. An IP65 waterproof LED light fixture, PC housing resistant to UV & impacts, silicon rubber gasket;
2. Quality LED chips, lifespan > 50,000 hours, mild light, no flicker, no glare and no noise;
3. Opaque PC cover with light diffusing agent, light transmittance up to 83%;
4. PC clips or stainless steel clips, two of them suspended to hang the cover while opening;
5. Reflector: t=0.4mm cold rolled iron plate, U-shaped high intensity bending, phosphating, spraying and powder coating

## Applications recommendation:

Can be applied in wet interior, dusty place and outdoor places such as Cellars, Sheds, Plant rooms, Warehouses, Open and closed parking areas, Workstations, Corridors etc.

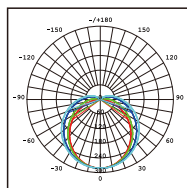
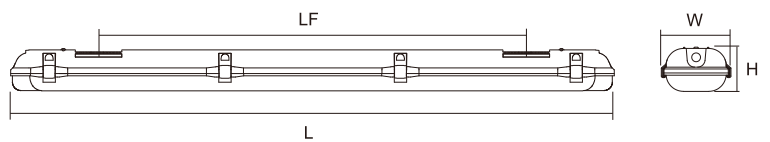

V3118BS-LM Photometric

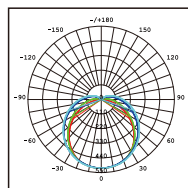

V3136BS-LM Photometric

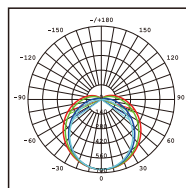

V3158BS-LM Photometric

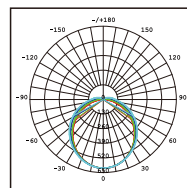

V3218BS-LM Photometric

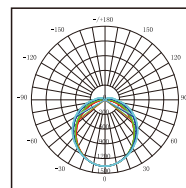

V3236BS-LM Photometric

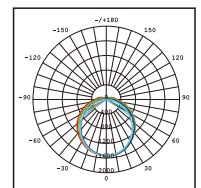

V3258BS-LM Photometric

Type	Power	Luminous	CCT	Dimensions(L×W×H)	Q'ty/ctn	Packing size
V3118BS/DS-LM	12W	1600lm	4000K/6500K	650×82×86×347mm	12PCS	671×343×290mm
V3136BS/DS-LM	24W	3200lm	4000K/6500K	1260×82×86×900mm	9PCS	1281×261×290mm
V3158BS/DS-LM	26W	3400lm	4000K/6500K	1560×82×86×1200mm	9PCS	1581×270×290mm
V3218BS/DS-LM	23W	3100lm	4000K/6500K	650×127×86×347mm	9PCS	671×399×284mm
V3236BS/DS-LM	47W	6000lm	4000K/6500K	1260×127×86×900mm	6PCS	1281×399×196mm
V3258BS/DS-LM	52W	6600lm	4000K/6500K	1560×127×86×1200mm	6PCS	1581×399×196mm

Attention: The lumen tolerance is ± 10%.

# VWP-LC001 IP65 Waterproof LED light

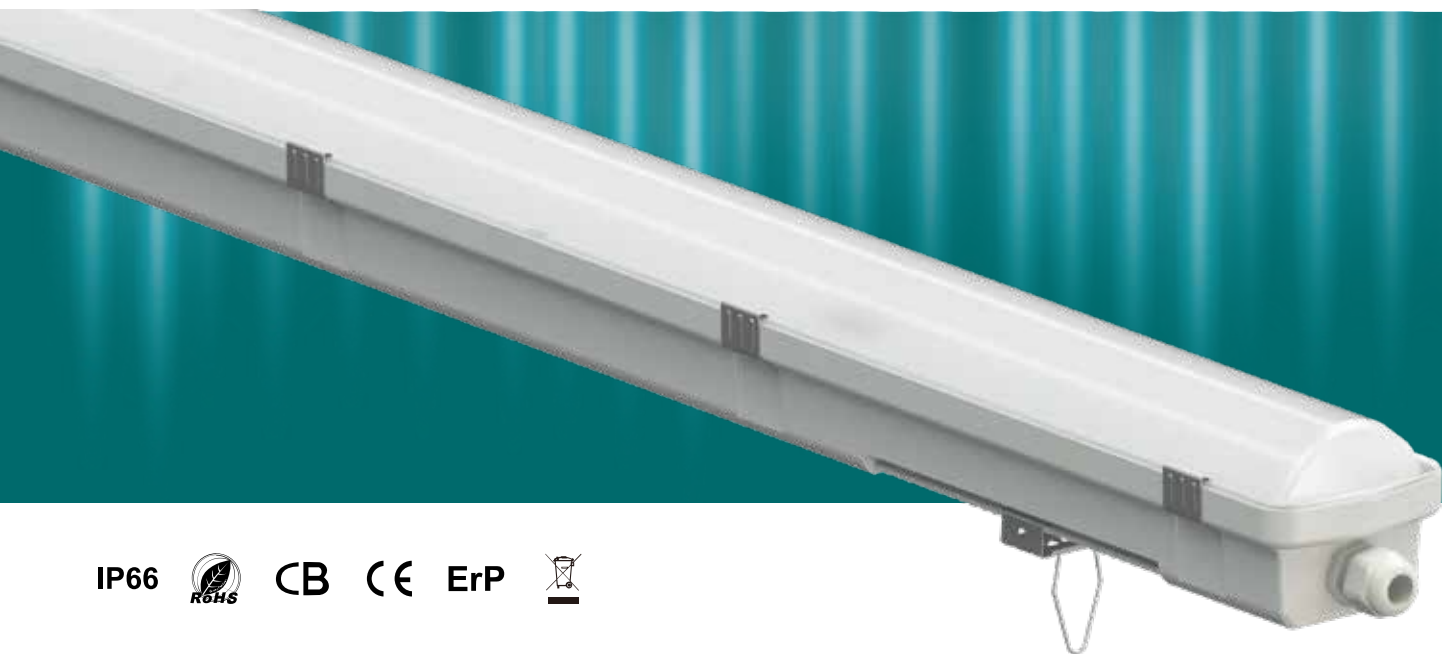

## General characteristics:

1. Durable design: protection grade is up to IP65 and IK08, use clips to connect body and diffuser
2. Easy installation: screw, brackets and the others accessories in put into the light
3. Economical and practical: through optimum design for the size, lights has highlight efficiency
4. Uniform luminance.
5. SDCM  $\leq$  5, CRI  $>$  80
6. 180LM/W other parameter requirements need to be customized
7. Lifespan: 50000hrs
8. ambient temperature:  $-20\sim+40^{\circ}\text{C}$

## Applications recommendation:

Supermarket, shopping mall, dining room, school, Hospital, parking lot, warehouse, corridor etc.

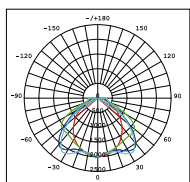
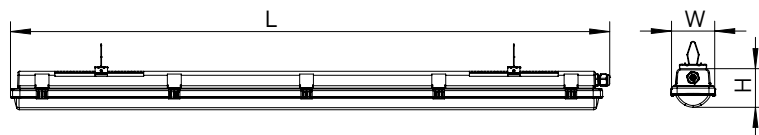

VWP-LC001-600

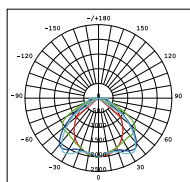

VWP-LC001-1200

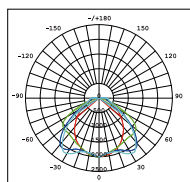

VWP-LC001-1500

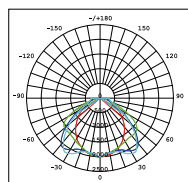

VWP-LC001-1800

Type	Power	Luminous	CCT	Dimensions(L×W×H)	Q'ty/ctn	Packing size
VWP-LC001-600 18W	18	3240lm	4000K	600×89×78	9PCS	620×290×265mm
VWP-LC001-1200 36W	36	6480lm	4000K	1200×89×78	6PCS	1220×290×185mm
VWP-LC001-1500 50W	50	9000lm	4000K	1500×89×78	6PCS	1520×290×185mm
VWP-LC001-1800 70W	70	12600lm	4000K	1800×89×78	4PCS	1820×200×185mm

Attention: The lumen tolerance is  $\pm 10\%$ .



# T8D-LM IP65 Waterproof LED light



## General characteristics:

1. An IP65 waterproof LED light fixture, PC housing resistant to UV & impacts, silicon rubber gasket;
2. Quality LED chips, lifespan > 50,000 hours, mild light, no flicker, no glare and no noise;
3. Opaque PC cover with light diffusing agent, light transmittance up to 83 %;
4. PC clips or stainless steel clips, two of them suspended to hang the cover while opening;
5. Aluminum reflector, anode oxidation treated, thermal conductivity > 190W/M.K.

## Applications recommendation:

Can be applied in wet interior, dusty place and outdoor places such as Cellars, Sheds, Plant rooms, Warehouses, Open and closed parking areas, Workstations, Corridors etc.

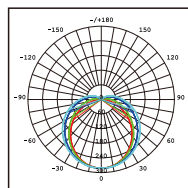
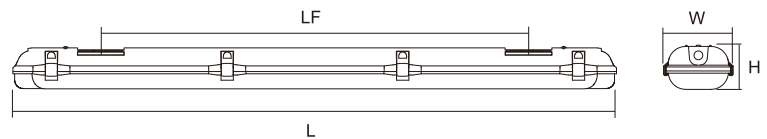

V3118D-LM Photometric

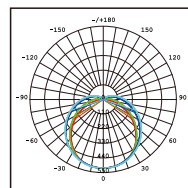

V3136D-LM Photometric

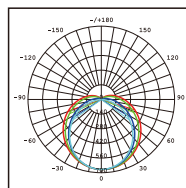

V3158D-LM Photometric

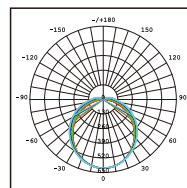

V3218D-LM Photometric

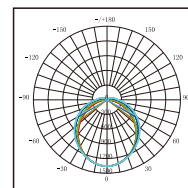

V3236D-LM Photometric

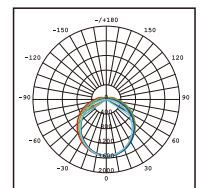

V3258D-LM Photometric

Type	Power	Luminous	CCT	Dimensions(L×W×H)	Q'ty/ctn	Packing size
V3118D-LM	12W	1360lm	4000K	664×90×90×350mm	12PCS	685×395×300mm
V3218D-LM	24W	2700lm	4000K	664×140×90×350mm	9PCS	685×450×300mm
V3136D-LM	24W	2700lm	4000K	1274×90×90×900mm	9PCS	1295×300×300mm
V3236D-LM	48W	5500lm	4000K	1274×140×90×900mm	6PCS	1295×450×205mm
V3158D-LM	27W	3000lm	4000K	1574×90×90×1200mm	9PCS	1595×300×300mm
V3258D-LM	54W	6000lm	4000K	1574×140×90×1200mm	6PCS	1595×450×205mm

Attention: The lumen tolerance is ± 10%.

# T8G-LM IP65 Waterproof LED light



IP66



## General characteristics:

1. An IP65 waterproof LED light fixture, PC housing resistant to UV & impacts, silicon rubber gasket;
2. Opaque PC cover with light diffusing agent;
3. Plastic gear tray holders connected to the body for easy installation & maintenance;
4. PC clips or stainless steel clips, two of them suspended to hang the cover while opening;
5. Aluminum reflector, anode oxidation treated, thermal conductivity >190W/M.K.

## Applications recommendation:

Can be applied in wet interior, dusty place and outdoor places such as Cellars, Sheds, Plant rooms, Warehouses, Open and closed parking areas, Workstations, Corridors etc.

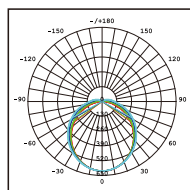
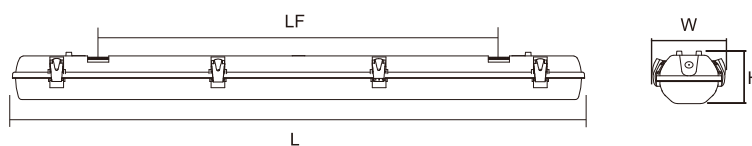

V3218G-LM Photometric

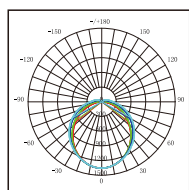

V3236G-LM Photometric

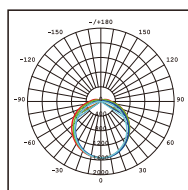

V3258G-LM Photometric

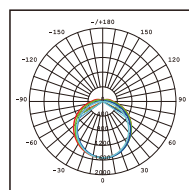

V3270G-LM Photometric

Type	Power	Luminous	CCT	Dimensions(L×W×H×LF)	Q'ty/ctn	Packing size
V3218G-LM	25W	2500lm	4000K/6500K	670×162×110×480mm	9PCS	685×460×230mm
V3236G-LM	50W	5000lm	4000K/6500K	1274×162×110×890mm	4PCS	1295×305×160mm
V3258G-LM	60W	6000lm	4000K/6500K	1574×162×110×1000mm	4PCS	1595×305×160mm
V3270G-LM	70W	7000lm	4000K/6500K	1860×145×103×930mm	4PCS	1880×305×160mm

Attention: The lumen tolerance is ± 10%.

# T8DN-LM IP65 Waterproof LED light



## General characteristics:

1. An IP65 waterproof LED light fixture, PC housing resistant to UV & impacts, silicon rubber gasket;
2. Opaque PC cover with light diffusing agent;
3. PC clips or stainless steel clips, two of them suspended to hang the cover while opening;
4. Aluminum reflector, anode oxidation treated, thermal conductivity >190W/M.K.

## Applications recommendation:

Can be applied in wet interior, dusty place and outdoor places such as Cellars, Sheds, Plant rooms, Warehouses, Open and closed parking areas, Workstations, Corridor etc.

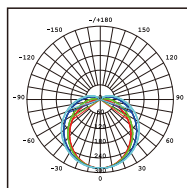
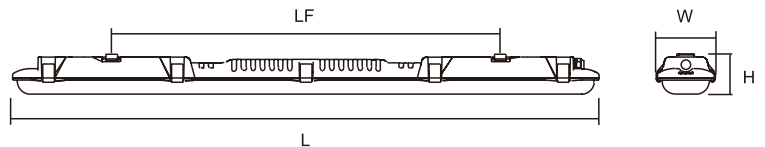

V3118D-LM Photometric

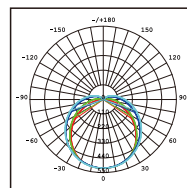

V3136D-LM Photometric

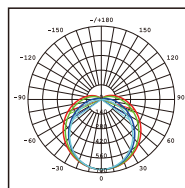

V3158D-LM Photometric

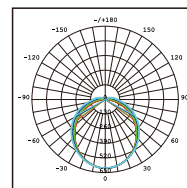

V3218D-LM Photometric

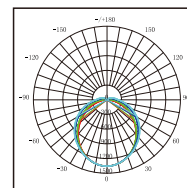

V3236D-LM Photometric

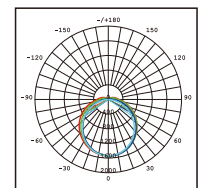

V3258D-LM Photometric

Type	Power	Luminous	CCT	Dimensions(L×W×H)	Q'ty/ctn	Packing size
V3118DN-LM	13W	1300lm	4000K	653×83×80×420mm	12PCS	680×367×280mm
V3218DN-LM	25W	2500lm	4000K	653×128×80×420mm	9PCS	680×410×280mm
V3136DN-LM	25W	2500lm	4000K	1263×83×80×835mm	9PCS	1290×280×280mm
V3236DN-LM	52W	5200lm	4000K	1263×128×80×835mm	6PCS	1290×410×190mm
V3158DN-LM	30W	3000lm	4000K	1563×83×80×1036mm	9PCS	1590×280×280mm
V3258DN-LM	65W	6500lm	4000K	1563×128×80×1090mm	6PCS	1590×410×190mm

Attention: The lumen tolerance is ± 10%.

# VLOE-T IP65 Waterproof LED light

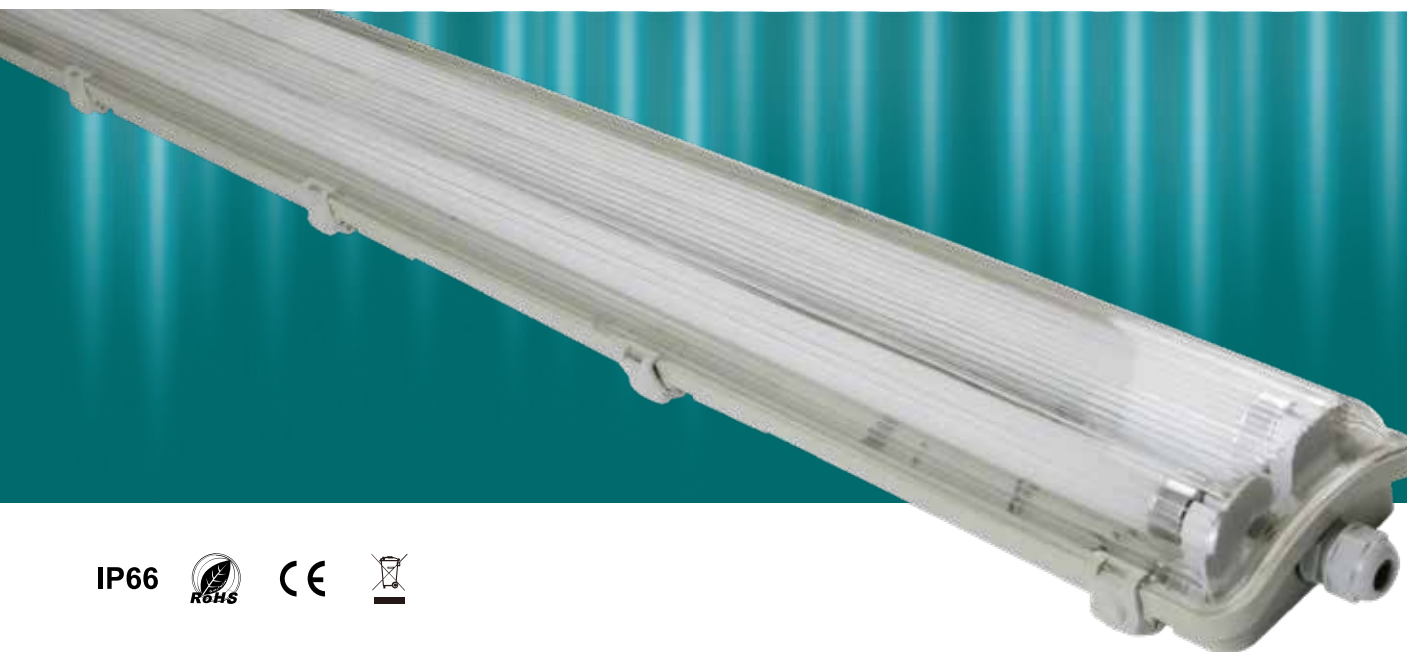

IP66



## PRODUCT FEATURES

- LED: International first-class quality LED light source with a variety of color temperature for choice.
- Lamp body: Injection moulded with strengthening ribs, opaque UV stabilized PC material, sealing strip in natural silicone rubber.
- Clips: PC or metal material. The clips at two sides of the cover have the suspending function that could connect cover and body all the time once it is opened. The clips are designed for easy open by hand without tools.
- Lamp cover: Injection moulded, high impact resistant PC material with light diffusing agent which could shed soft light. Light transmittance >85%.
- Reflector: no reflector

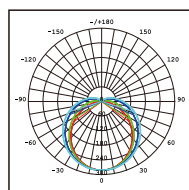
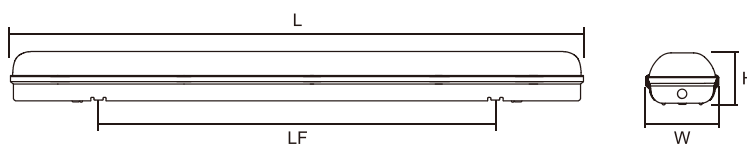

VLOE-106T Photometric

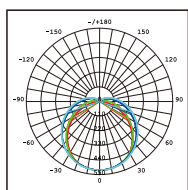

VLOE-112T Photometric

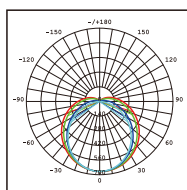

VLOE-115T Photometric

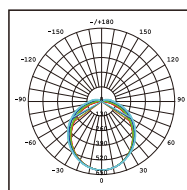

VLOE-206T Photometric

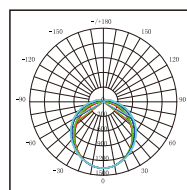

VLOE-212T Photometric

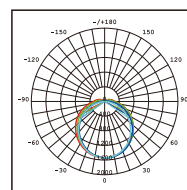

VLOE-215T Photometric

Type	Voltage	Power	CCT	Dimensions(L×W×H×LF)	Q'ty/ctn	Packing size
VLOE-106T	220-240V	1X9W	4000K/6500K	668x73x57x316mm	15PCS	693×243×320mm
VLOE-112T	220-240V	1X18W	4000K/6500K	1280x73x57x860mm	12PCS	305×243×260mm
VLOE-115T	220-240V	1X24W	4000K/6500K	1580x73x57x1105mm	12PCS	1605×243×260mm
VLOE-206T	220-240V	2X9W	4000K/6500K	668x116x56x316mm	10PCS	760×260×320mm
VLOE-212T	220-240V	2X18W	4000K/6500K	1270x116x56x860mm	8PCS	1360×260×260mm
VLOE-215T	220-240V	2X24W	4000K/6500K	1568x116x56x1105mm	8PCS	1660×260×260mm

Attention: The lumen tolerance is ± 10%.



# T5B-LM IP65 Waterproof LED light



## General characteristics:

1. An IP65 waterproof LED light fixture;
2. Mild light, no flicker, no glare and no noise;
3. Cost-saving and eco-friendly, lifespan > 50000h ;
4. Opaque PC cover with light diffusing agent, transmittance > 83%, with high resistance to UV & impacts;
5. "T" shape rotatable reflector supports, linked by plastic brace;
6. Gasket sealed.

## Applications recommendation:

Can be applied in wet interior, dusty place and outdoor places such as Cellars, Sheds, Plant rooms, Warehouses, Open and closed parking areas, Workstations, Corridors etc.

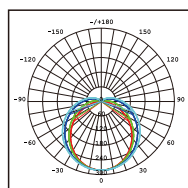
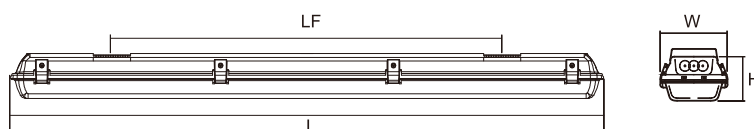

V5114B-LM Photometric

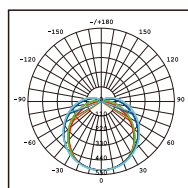

V5128B-LM Photometric

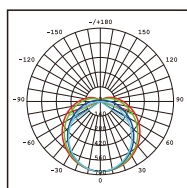

V5135B-LM Photometric

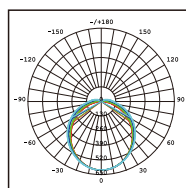

V5214B-LM Photometric

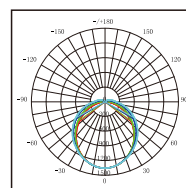

V5228B-LM Photometric

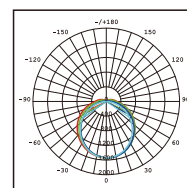

V5235B-LM Photometric

Type	Power	Luminous	CCT	Dimensions(L×W×H)	Q'ty/ctn	Packing size
V5114B-LM	11W	1430lm	4000K/6500K	618×81×74×411mm	12PCS	630×325×235mm
V5128B-LM	21W	2730lm	4000K/6500K	1215×81×74×800mm	12PCS	1230×325×235mm
V5135B-LM	27W	3510lm	4000K/6500K	1515×81×74×1000mm	12PCS	1530×325×235mm
V5214B-LM	21W	2730lm	4000K/6500K	618×116×74×411mm	8PCS	630×305×240mm
V5228B-LM	45W	5850lm	4000K/6500K	1215×116×74×800mm	8PCS	1230×305×240mm
V5235B-LM	55W	7150lm	4000K/6500K	1515×116×74×1000mm	8PCS	1530×305×240mm

Attention: The lumen tolerance is ± 10%.



# T5C-LM IP65 Waterproof LED light



IP65



## General characteristics:

1. An IP65 waterproof LED light fixture, PC housing resistant to UV & impacts, silicon rubber gasket;
2. Quality LED chips, lifespan > 30,000 hours, mild light, no flicker, no glare and no noise;
3. Opaque PC cover with light diffusing agent, light transmittance > 83%;
4. Plastic gear tray holders connected to the body for easy installation & maintenance;
5. PC clips or stainless steel clips, two of them suspended to hang the cover while opening;
6. Aluminum reflector, anode oxidation treated, thermal conductivity > 190W/M.K.

## Applications recommendation:

Can be applied in wet interior, dusty place and outdoor places such as Cellars, Sheds, Plant rooms, Warehouses, Open and closed parking areas, Workstations, Corridors etc.

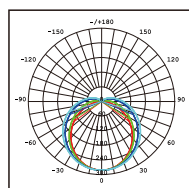
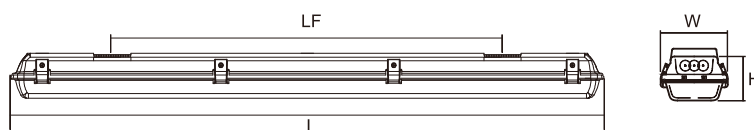

V5114C-LM Photometric

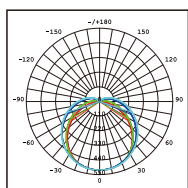

V5128C-LM Photometric

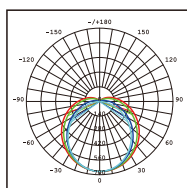

V5135C-LM Photometric

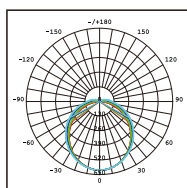

V5214C-LM Photometric

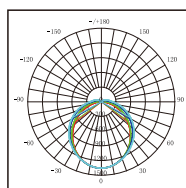

V5228C-LM Photometric

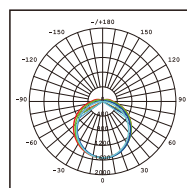

V5235C-LM Photometric

Type	Power	Luminous	CCT	Dimensions(L×W×H×LF)	Q'ty/ctn	Packing size
V5114C-LM	11W	1430lm	4000K/6500K	618×81×74×411mm	12PCS	705×340×190mm
V5128C-LM	21W	2730lm	4000K/6500K	1215×81×74×800mm	12PCS	1245×340×190mm
V5135C-LM	27W	3510lm	4000K/6500K	1515×81×74×1000mm	12PCS	1545×345×190mm
V5214C-LM	21W	2730lm	4000K/6500K	618×116×74×411mm	8PCS	645×245×245mm
V5228C-LM	45W	5850lm	4000K/6500K	1215×116×74×800mm	8PCS	1245×245×245mm
V5235C-LM	55W	7150lm	4000K/6500K	1515×116×74×1000mm	8PCS	1545×245×245mm

Attention: The lumen tolerance is ± 10%.

# VE-DL-S Batten/Linear LED light

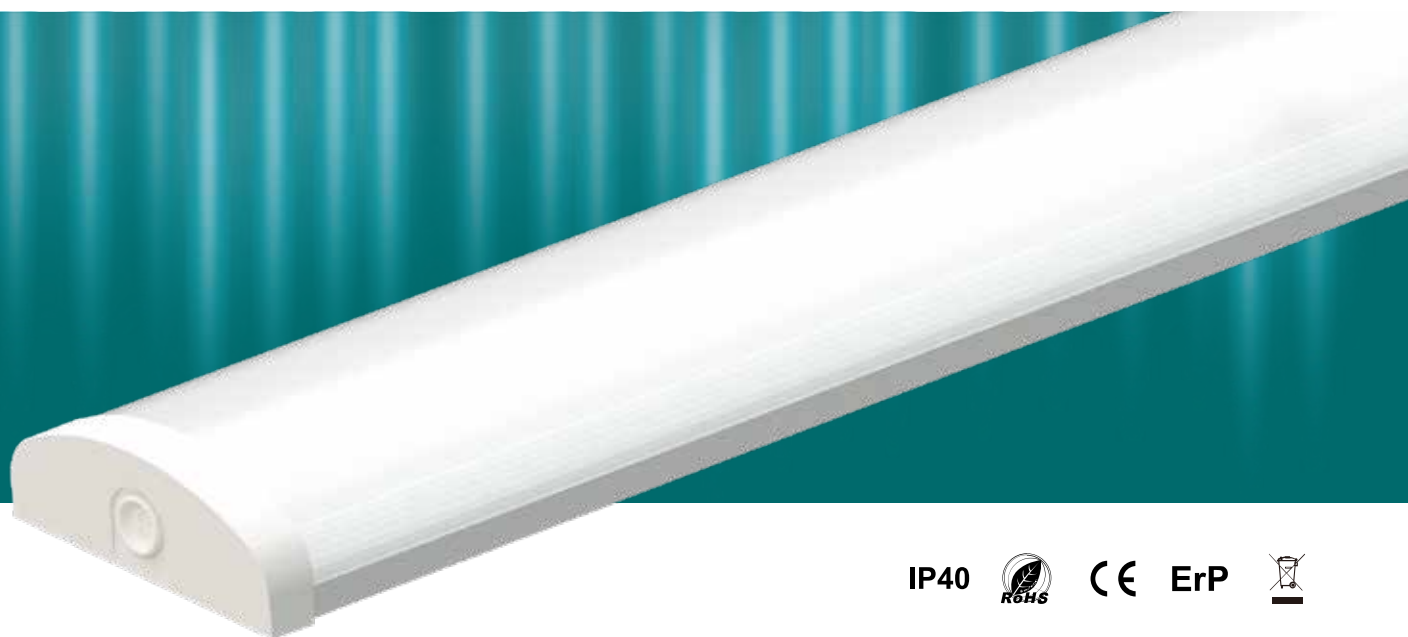

## General characteristics:

1. Ultra wide luminescent surface, ultra thin size
2. Lamps and lanterns need to open lamp cover to wire, the lamp cover adopts the limit fixed, disassembly is convenient
3. The back of housing welding mounting plate can be installed according to the selection of the accessories both for ceiling and suspension, no need to remove the attachment
4. Clip-free, simple and concise appearance

## Applications recommendation:

Supermarkets, warehouses, corridors, subway stations, offices, etc.

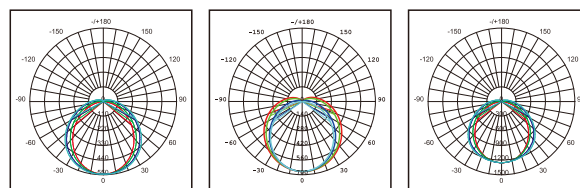
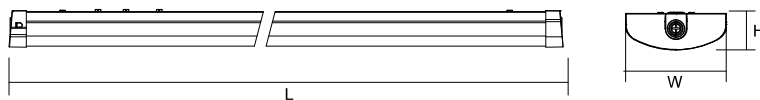

VE106DL-S Photometric VE112DL-S Photometric VE115DL-S Photometric

Type	Power	Luminous	CCT	Dimensions(L×W×H×LF)	Q'ty/ctn	Packing size
VE106DL-S	20W	2000lm	4000K	590×142×53×440mm	6PCS	655×350×165mm
VE112DL-S	35W	3500lm	4000K	1150×142×53×1000mm	6PCS	1215×350×165mm
VE115DL-S	35W	3500lm	4000K	1430×142×53×1280mm	6PCS	1495×350×165mm
VE112DL-S	45W	4500lm	4000K	1150×142×53×1000mm	6PCS	1215×350×165mm
VE115DL-S	58W	5800lm	4000K	1430×142×53×1280mm	6PCS	1495×350×165mm
VE118DL-S	75W	7500lm	4000K	1710×142×53×1560mm	6PCS	1775×350×165mm

Attention: The lumen tolerance is ± 10%.

# VE-DL-SU Batten/Linear LED light

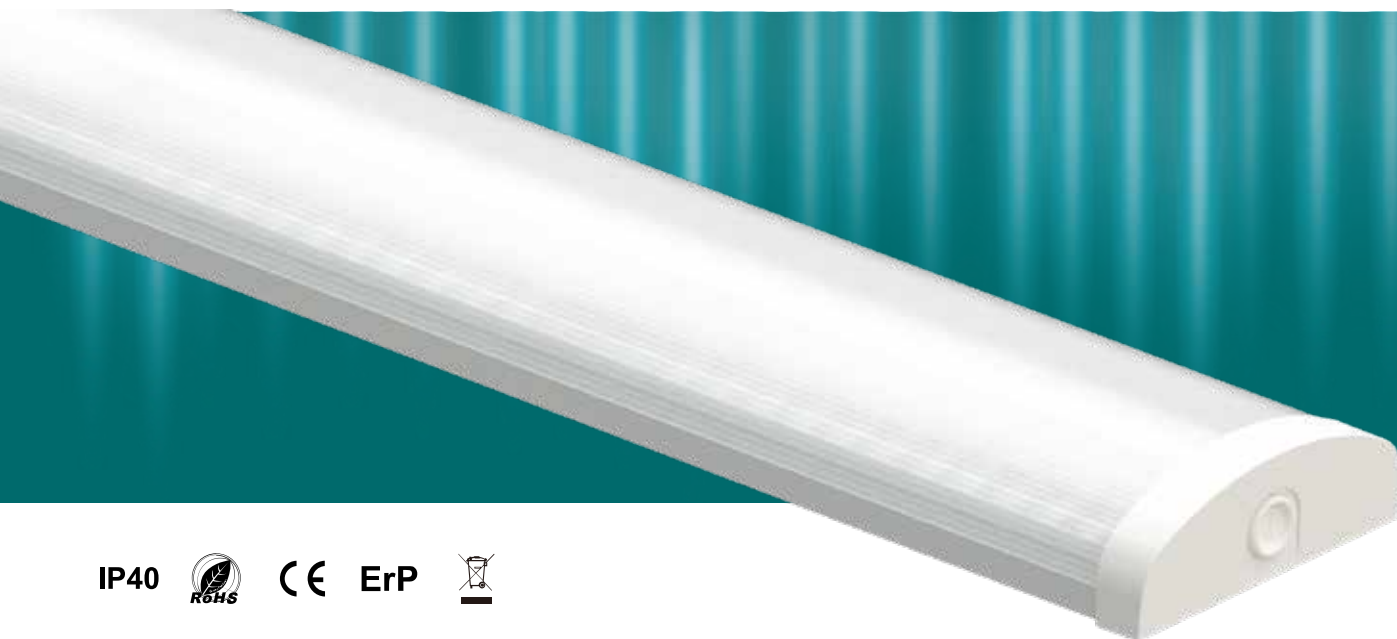

## General characteristics:

1. Ultra wide luminescent surface, ultra thin size
2. Lamps and lanterns need to open lamp cover to wire, the lamp cover adopts the limit fixed, disassembly is convenient
3. The back of housing welding mounting plate can be installed according to the selection of the accessories both for ceiling and suspension, no need to remove the attachment
4. Clip-free, simple and concise appearance
5. Use transparent PC cover, High light transmittance.

## Applications recommendation:

Supermarkets, warehouses, corridors, subway stations, offices, etc.

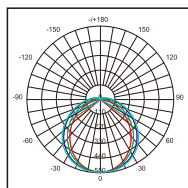

VE106DL-SU Photometric

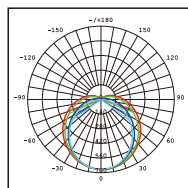

VE112DL-SU Photometric

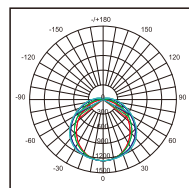

VE115DL-SU Photometric

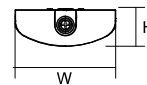
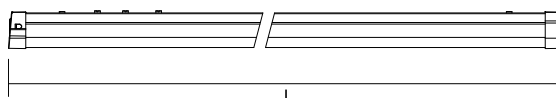

Type	Power	Luminous	CCT	Dimensions(L×W×H×LF)	Q'ty/ctn	Packing size
VE106DL-SU	20W	2000lm	4000K	590×142×53×440mm	6PCS	655×350×165mm
VE112DL-SU	35W	3500lm	4000K	1150×142×53×1000mm	6PCS	1215×350×165mm
VE115DL-SU	35W	3500lm	4000K	1430×142×53×1280mm	6PCS	1495×350×165mm
VE112DL-SU	45W	4500lm	4000K	1150×142×53×1000mm	6PCS	1215×350×165mm
VE115DL-SU	58W	5800lm	4000K	1430×142×53×1280mm	6PCS	1495×350×165mm
VE118DL-SU	75W	7500lm	4000K	1710×142×53×1560mm	6PCS	1775×350×165mm

Attention: The lumen tolerance is ± 10%.

# DB-TO Batten/Linear LED light

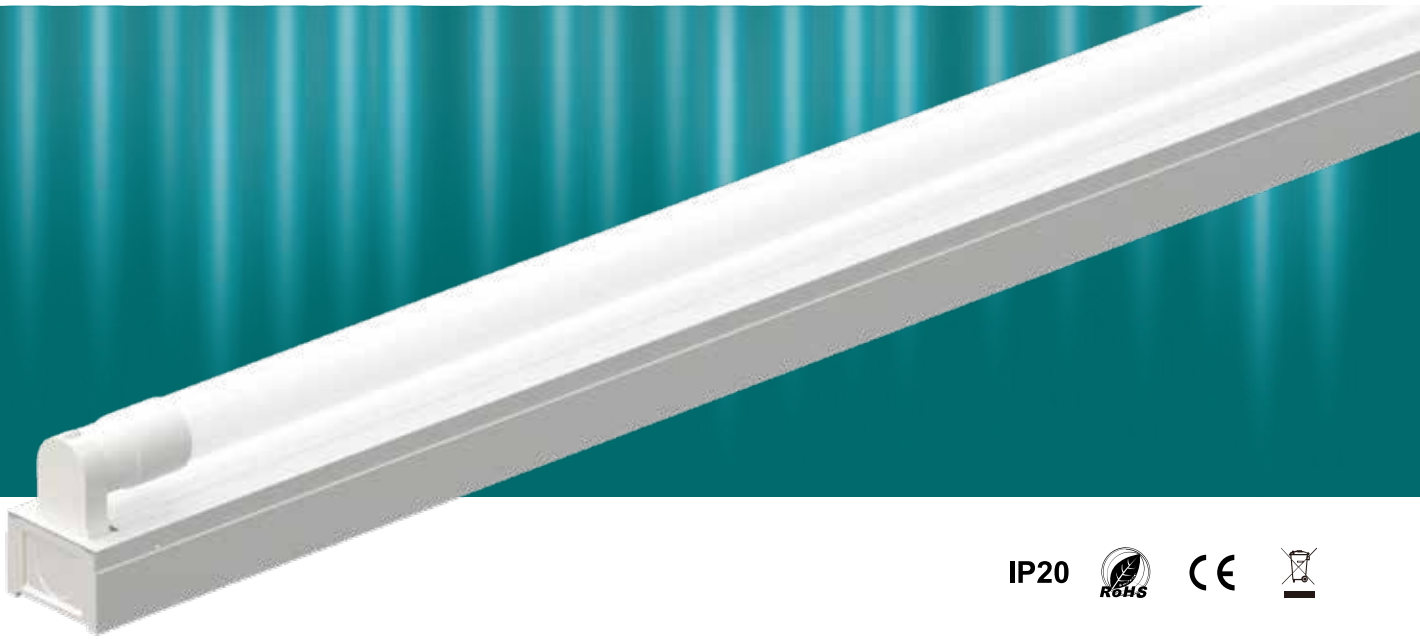

## General characteristics:

1. metal material, white spray powder lamp body.
2. T-LED tube, easy to replace.
3. Economical structure, quick installation.

## Applications recommendation:

Applicable places: parking lot, general workshop, warehouse, supermarket, etc

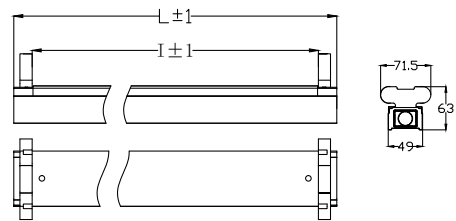
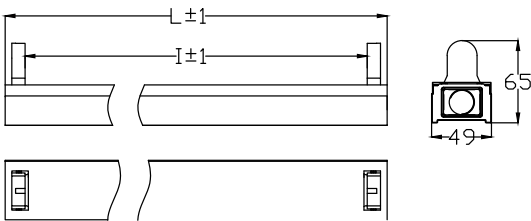

Type	Power	Luminous	CCT	Dimensions(L×W×H)	Q'ty/ctn	Packing size
VE106DB-1T08	8W	800lm	6500K	621×50×65mm	14PCS	653×220×135mm
VE106DB-1T10	10W	1000lm	6500K	621×50×65mm	14PCS	653×220×135mm
VE112DB-1T16	16W	1600lm	6500K	1230×50×65mm	14PCS	1261×220×135mm
VE112DB-1T20	20W	2000lm	6500K	1230×50×65mm	14PCS	1261×220×135mm
VE206DB-2T08	16W	1600lm	6500K	621×71×62mm	14PCS	653×220×135mm
VE206DB-2T10	20W	2000lm	6500K	621×71×62mm	14PCS	653×220×135mm
VE212DB-2T16	32W	3200lm	6500K	1230×71×62mm	14PCS	1261×220×135mm
VE212DB-2T20	40W	4000lm	6500K	1230×71×62mm	14PCS	1261×220×135mm

Attention: The lumen tolerance is  $\pm 10\%$ .

# VE-DB-02 Batten/Linear LED light

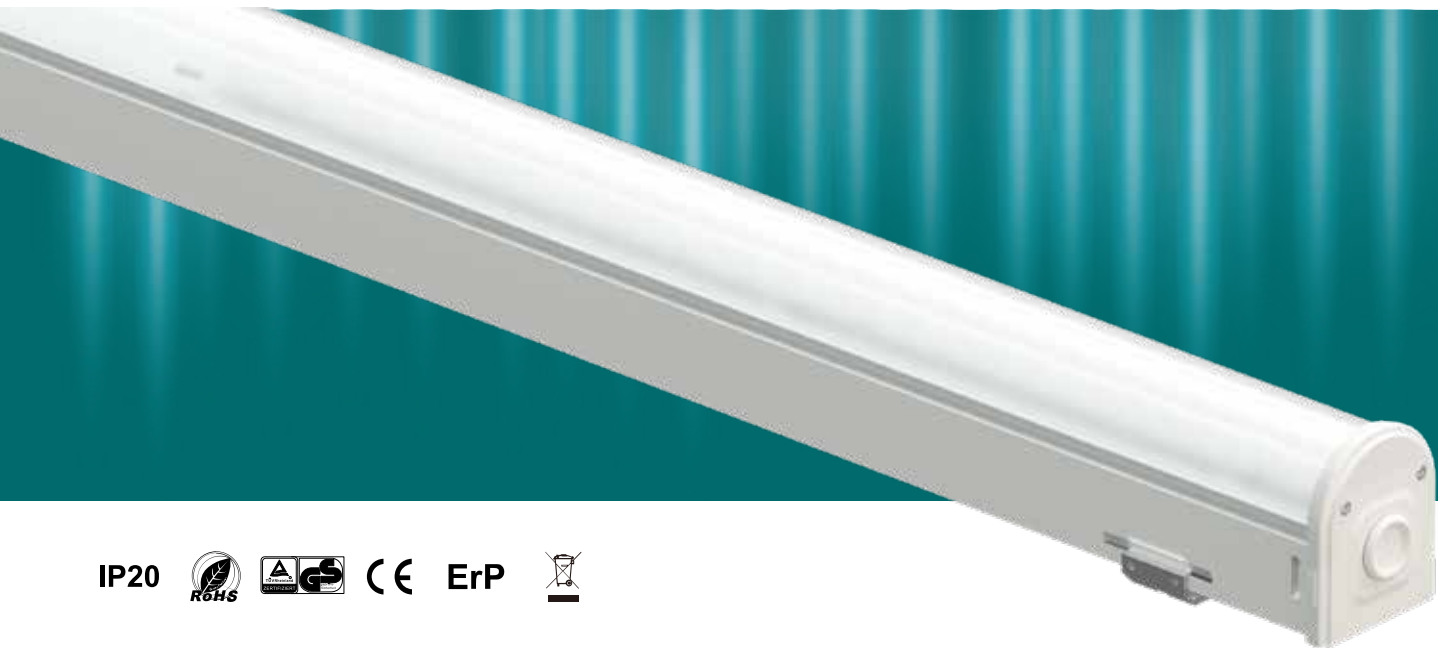

## General characteristics:

1. Punching formed housing by cold rolled steel plate, powder coated surface;
2. Opaque PC cover with light diffusing agent;
3. Drawer type structure for easily external wiring;
4. The power cable can be installed at the back of the housing too, see picture

## Applications recommendation:

Office, household, supermarket, corridor, metro, warehouse, etc.

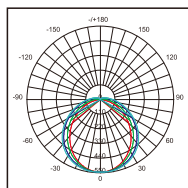

VE106DB02 Photometric

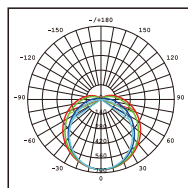

VE112DB02 Photometric

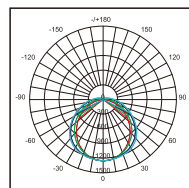

VE115DB02 Photometric

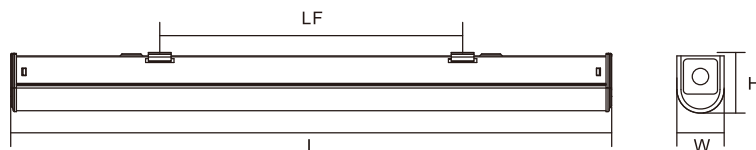

Type	Power	Luminous	CCT	Dimensions(L×W×H×LF)	Q'ty/ctn	Packing size
VE106DB-02	18W	2550lm	3000K/4000K	571×63×76×450mm	8PCS	618×300×182mm
VE112DB-02	36W	4700lm	3000K/4000K	1133×63×76×900mm	8PCS	1181×300×182mm
VE115DB-02	55W	7400lm	3000K/4000K	1415×63×76×1200mm	6PCS	1463×230×182mm

Attention: The lumen tolerance is ± 10%.



# VE-DC Batten/Linear LED light

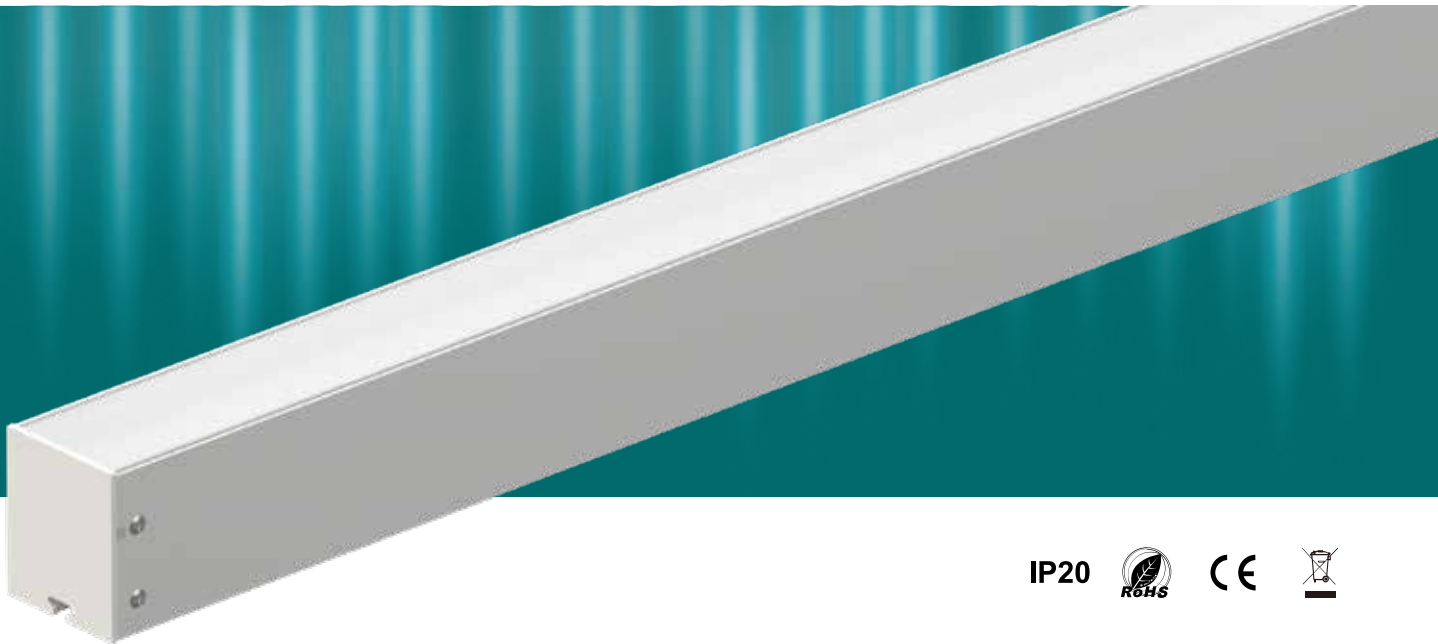

## General characteristics:

1. Ultra wide luminescent surface, ultra thin size;
2. Lamps and lanterns need to open lamp cover to wire, the lamp cover adopts the limit fixed, disassembly is convenient;
3. The back of housing welding mounting plate can be installed according to the selection of the accessories both for ceiling and suspension, no need to remove the attachmen;
4. Clip-free, simple and concise appearance.

## Applications recommendation:

Can be applied in wet interior, dusty place and outer places such as Cellars, Sheds, Plant rooms, Warehouses, Open and closed parking areas, Workstations, Corridors etc

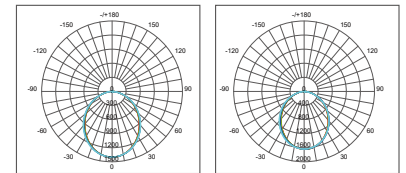
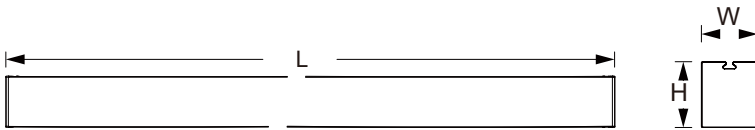

VE112DC 30W Photometric VE112DC 36W Photometric

Type	Power	Luminous	CCT	Dimensions(L×W×H)	Q'ty/ctn	Packing size
VE106DC18865	18W	2160lm	6500K	605*68*58mm	6PCS	685*200*178mm
VE106DC18865-TW1	18W	2160lm	6500K	605*68*58mm	6PCS	685*200*160mm
VE112DC30865	30W	3600lm	6500K	1205*68*58mm	6PCS	1285*200*178mm
VE112DC30865-TW1	30W	3600lm	6500K	1205*68*58mm	6PCS	1285*200*160mm
VE112DC36865	36W	4320lm	6500K	1205*68*58mm	6PCS	1285*200*178mm
VE112DC36865-TW1	36W	4320lm	6500K	1205*68*58mm	6PCS	1285*200*160mm
VE112DC30840	30W	3600lm	4000K	1205*68*58mm	6PCS	1285*200*178mm
VE112DC30840-TW1	30W	3600lm	4000K	1205*68*58mm	6PCS	1285*200*160mm
VE112DC36840	36W	4320lm	4000K	1205*68*58mm	6PCS	1285*200*178mm
VE112DC36840-TW1	36W	4320lm	4000K	1205*68*58mm	6PCS	1285*200*160mm
VE115DC45865	45W	5400lm	6500K	1505*68*58mm	6PCS	1585*200*178mm
VE115DC45865-TW1	45W	5400lm	6500K	1505*68*58mm	6PCS	1585*200*160mm
VE115DC52865	52W	6240lm	6500K	1505*68*58mm	6PCS	1585*200*178mm
VE115DC52865-TW1	52W	6240lm	6500K	1505*68*58mm	6PCS	1585*200*160mm
VE118DC60865	60W	7200lm	6500K	1805*68*58mm	6PCS	1885*200*178mm
VE118DC60865-TW1	60W	7200lm	6500K	1805*68*58mm	6PCS	1885*200*160mm
VE118DC70865	70W	8400lm	6500K	1805*68*58mm	6PCS	1885*200*178mm
VE118DC70865-TW1	70W	8400lm	6500K	1805*68*58mm	6PCS	1885*200*160mm

Attention: The lumen tolerance is ± 10%.

# VC-PL IP65 Waterproof LED light



IP20



## General characteristics:

1. PC housing resistant to UV & impacts, silicon rubber gasket IP66, IK10;
2. Quality LED chips, SMD2835, mild light, no flicker, no glare and no noise;
3. Opaque PC cover with light diffusing agent, light transmittance > 80%;
4. Clip-free.

## Applications recommendation:

Can be applied in wet interior, dusty place and outer places such as Cellars, Sheds, Plant rooms, Warehouses, Open and closed parking areas, Workstations, Corridors etc

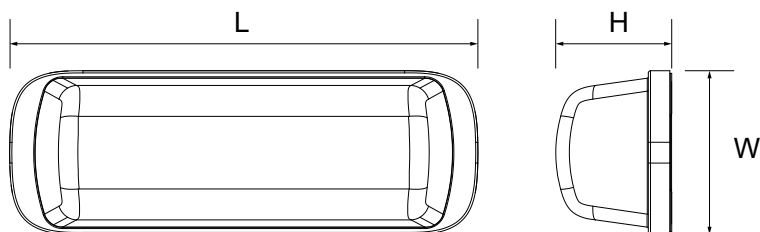

Type	Power	Luminous	CCT	Dimensions(L×W×H)	Q'ty/ctn	Packing size
VE-PL	3W	360lm	3000K/4000K	327×104×82mm	12pcs	355×330×350mm
VE-PLE (1.5w3h)	3W	360lm	3000K/4000K	327×104×82mm	12pcs	355×330×350mm
VE-PLI	3W	360lm	3000K/4000K	327×104×82mm	12pcs	355×330×350mm
VE-PL	3W	360lm	3000K/4000K	327×104×82mm	12pcs	355×330×350mm

Attention: The lumen tolerance is ± 10%.

# VC112E IP66 Waterproof LED light



IP66 IK10   ErP 

## General characteristics:

1. PC housing resistant to UV & impacts, silicon rubber gasket IP66, IK10;
2. Quality LED chips, SMD2835, mild light, no flicker, no glare and no noise;
3. Opaque PC cover with light diffusing agent, light transmittance > 80%;
4. Clip-free.

## Applications recommendation:

Can be applied in wet interior, dusty place and outer places such as Cellars, Sheds, Plant rooms, Warehouses, Open and closed parking areas, Workstations, Corridors etc

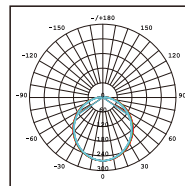
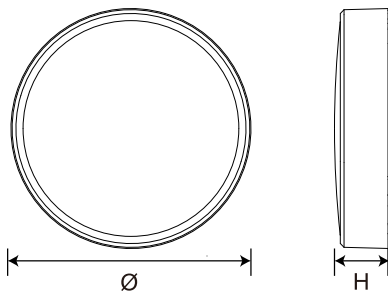

VC112E-15W Photometric

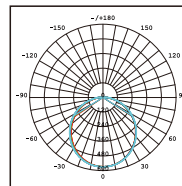

VC112E-16.5W Photometric

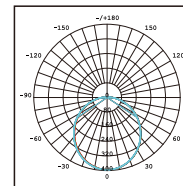

VC112E-21W Photometric

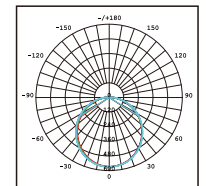

VC112E-22.5W Photometric

Type	Power	Luminous	CCT	Dimensions(Ø×H)	Q'ty/ctn	Packing size
VC112E-15W	15W	2000lm	3000/4000K	332x74mm	8PCS	680*340*348mm
VC112E-21W	21W	2750lm	3000/4000K	332x74mm	8PCS	680*340*348mm
VC112E-16.5WG	16.5W	2000lm	3000/4000K	332x74mm	8PCS	680*340*348mm
VC112E-22.5WG	22.5W	2750lm	3000/4000K	332x74mm	8PCS	680*340*348mm

Attention: The lumen tolerance is ± 10%.

# VC-FA IP65 Waterproof LED light



IP65   

## General characteristics:

1. An IP65 LED bulkhead light, ABS housing resistant;
2. Quality LED chips, SMD2835, mild light, no flicker;
3. Opaque PC cover with light diffusing agent;
4. Microwave sensor optional.

## Applications recommendation:

Bathroom room, corridor, balcony, etc.



Type	Power	Luminous	CCT	Dimensions	Q'ty/ctn	Packing size
VC108FA-12W	12W	1080lm	4000K-6500K	195×95×55mm	40	630×230×430mm
VC109FA-18W	18W	1620lm	4000K-6500K	225×100×55mm	40	630×250×480mm
VC107FB-12W	12W	1080lm	4000K-6500K	Ø175×55mm	40	630×380×380mm
VC108FB-18W	18W	1620lm	4000K-6500K	Ø210×55mm	30	680×320×460mm

Attention: The lumen tolerance is ± 10%.



# VC-FG IP54 Waterproof LED light



IP54



## General characteristics:

1. An IP54 LED bulkhead light, PC housing resistant to UV & impacts;
2. Quality LED chips, SMD2835, mild light, no flicker, no glare and no noise;
3. Opaque PC cover with light diffusing agent;
4. Microwave sensor, 3 CCT, Emergency optional.

## Applications recommendation:

Office, bedroom, living room, corridor, balcony, etc.

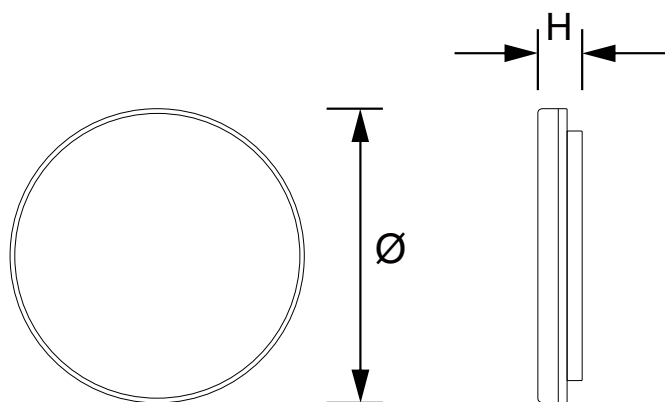

Type	Power	Luminous	CCT	Dimensions(Ø×H)	Q'ty/ctn	Packing size
VC109G-18W	18W	1620lm	4000K-6500K	Ø220×50mm	20	570×240×470mm
VC111G-24W	24W	2160lm	4000K-6500K	Ø280×50mm	10	570×300×305mm
VC112G-36W	36W	3240lm	4000K-6500K	Ø330×50mm	10	570×350×355mm

Attention: The lumen tolerance is ± 10%.

# VDP-PL LED Panel light

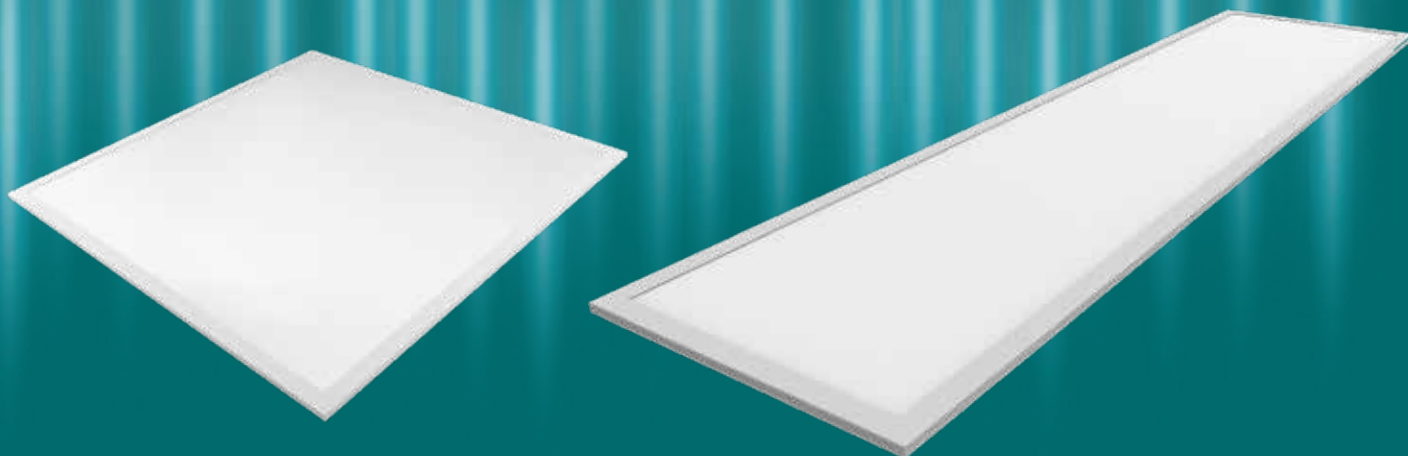

IP20   

## General characteristics:

1. Tidy and fashionable appearance, frame made with aviation aluminum, with surface abrasive blasting treatment.
2. High thermal conductivity ensured by aviation aluminum heat sink, prolongs LED life span.
3. Frame appearance to be customizable to fit unique needs from VIP clients.
4. Imported optic plate ensures high light output, pure light color, no glare and no dark zone.
5. Independent LED driver ensures Ripple<5% (flicker test based on IEEE1789-2015,no flicker when photographing), minimizes health risks to viewers

## Applications recommendation:

Office, meeting room, station hall, sitting room, corridor,shops, restaurant, etc.

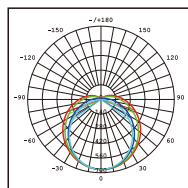

35W Photometric

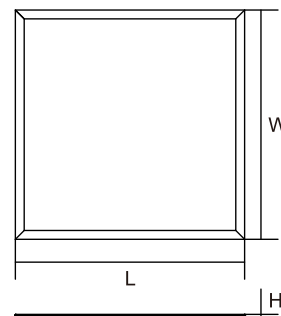
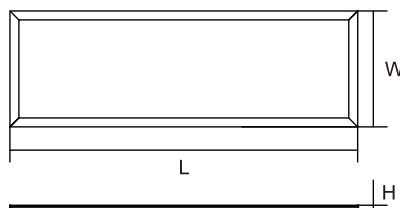

Type	Power	Luminous	CCT	Dimensions(L×W×H×LF)	Q'ty/ctn	Packing size
PLA6060C	35W	3800lm	4000K	595×595×8.5mm	5PCS	675×645×178mm
PLA30120C	35W	3500lm	4000K	1195×295×8.5mm	5PCS	1295×360×178mm
PLB6060C	35W	3800lm	4000K	595×595×33mm	6PCS	660×645×235mm
PLB30120C	35W	3500lm	4000K	1195×295×33mm	6PCS	1290×360×235mm

Attention: The lumen tolerance is ± 10%.

# VE-EMP/EM LED Panel light

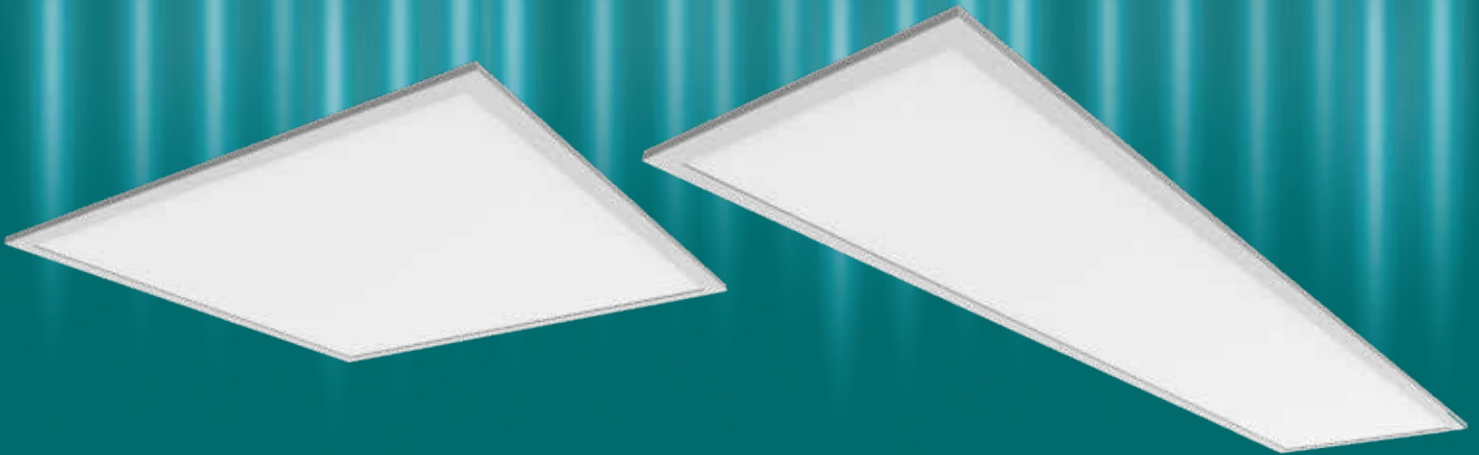

## General characteristics:

1. Tidy and fashionable appearance, frame made with aviation aluminum, with surface abrasive blasting treatment.
2. High thermal conductivity ensured by aviation aluminum heat sink, prolongs LED life span.
3. Frame appearance to be customizable to fit unique needs from VIP clients.
4. Imported optic plate ensures high light output, pure light color, no glare and no dark zone.
5. Independent LED driver ensures Ripple<5% (flicker test based on IEEE1789-2015, no flicker when photographing), minimizes health risks to viewers

## Applications recommendation:

Office, meeting room, station hall, sitting room, corridor, shops, restaurant, etc.

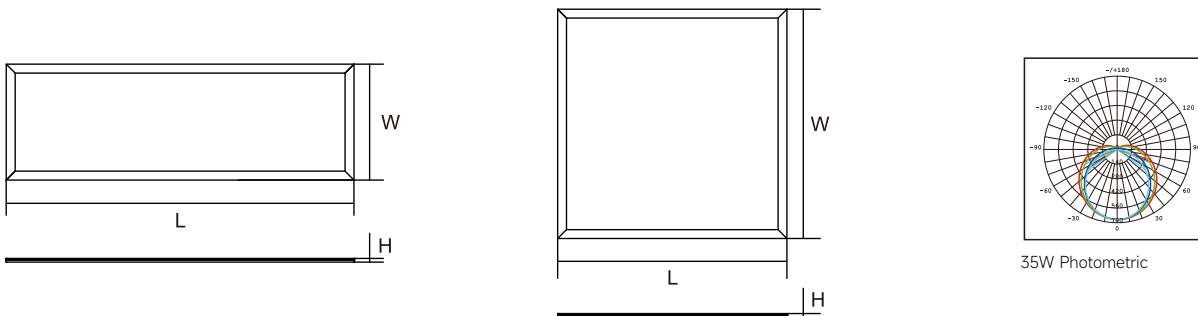

35W Photometric

Type	Power	Luminous	CCT	Dimensions(L×W×H)	Q'ty/ctn	Packing size
VE-EMP01	20W	2000lm	3000K/4000K/6500K	597×597×9.5mm	5PCS	662×662×180mm
VE-EMP02	20W	2000lm	3000K/4000K/6500K	1197×297×9.5mm	5PCS	1262×362×180mm
VE-EM01	20W	2000lm	3000K/4000K/6500K	597×597×9.5mm	2PCS	672×672×100mm
VE-EM02	20W	2000lm	3000K/4000K/6500K	1197×297×9.5mm	2PCS	1272×672×100mm

Attention: The lumen tolerance is ± 10%.

# CFL001 IP65 IK09 Ceiling fitting light(UFO)

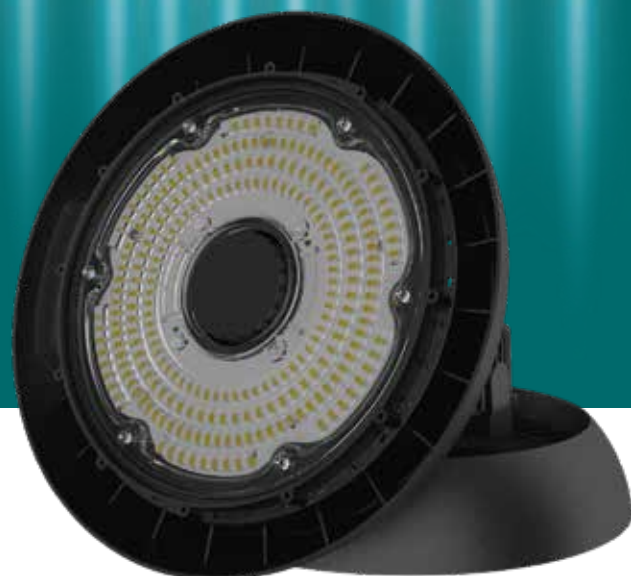

IP65 IK09



## General characteristics:

1. Reach grade B for new ERP energy efficiency level Maximum luminous efficiency up to 170lm/W, surpass most similar products on the market;
2. All aluminum die-cast lamp body; Not a cheap fin-type lamp body on the market; IK09;
3. Super heat dissipation to protect the wick. Bring higher working stability and improve service life;
4. Multi-layer PCB famous brand driver Customized high luminous efficiency LED particles.

## Applications recommendation:

Wide application prospects. Widely used in warehouse, tunnels, manufacturing, mining, petroleum, stadiums, supermarket, etc.

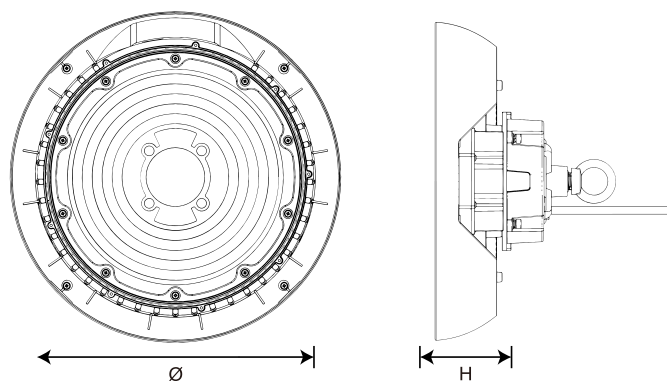

Type	Power	Luminous	CCT	Dimensions(L×W×H×LF)	Q'ty/ctn	Packing size
CFL001P-D258-100-150/7XX	100W	15000lm	6500K	258×116mm	1PCS	280×280×160mm
CFL001P-D298-150-150/7XX	150W	22500lm	6500K	298×116mm	1PCS	320×320×160mm
CFL001P-D298-200-150/7XX	200W	30000lm	6500K	298×116mm	1PCS	320×320×160mm
CFL001P-D258-100-170/7XX	100W	17000lm	6500K	258×116mm	1PCS	280×280×160mm
CFL001P-D298-150-170/7XX	150W	25500lm	6500K	298×116mm	1PCS	320×320×160mm
CFL001P-D298-200-170/7XX	200W	34000lm	6500K	298×116mm	1PCS	320×320×160mm
CFL001PV-D258-100-170/7XX	100W	17000lm	6500K	258×120mm	1PCS	280×280×160mm
CFL001PV-D298-150-170/7XX	150W	25500lm	6500K	298×120mm	1PCS	320×320×160mm
CFL001PV-D298-200-170/7XX	200W	34000lm	6500K	298×120mm	1PCS	320×320×160mm
CFL001P-D258-100-180/7XX	100W	18000lm	6500K	258×116mm	1PCS	280×280×160mm
CFL001P-D298-150-180/7XX	100W	27000lm	6500K	258×116mm	1PCS	320×320×160mm
CFL001P-D298-200-180/7XX	150W	36000lm	6500K	298×116mm	1PCS	320×320×160mm

Attention: The lumen tolerance is ± 10%.



# CFL001P IP65 IK09 Ceiling fitting light(UFO)



IP65 IK09   

## General characteristics:

1. Excellent LEDs guarantee high lumen maintain rate, low light decay;
2. All aluminum die-cast housing for the heat dissipation, higher working stability and improve service life;
3. High efficiency constant current driver;
4. IP65 Waterproof, IK09.

## Applications recommendation:

Wide application prospects. Widely used in warehouse, tunnels, manufacturing, mining, petroleum, stadiums, supermarket, etc.

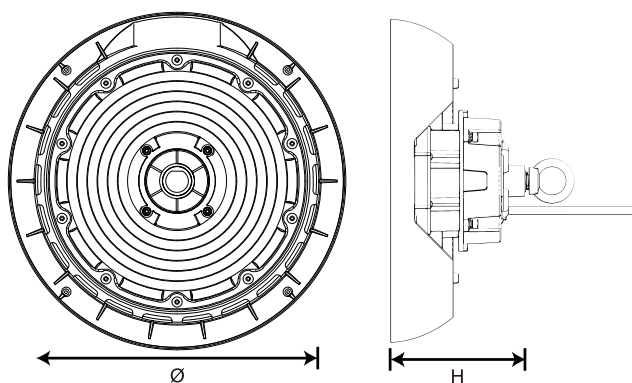

Type	Power	Luminous	CCT	Dimensions(L×W×H)	Q'ty/ctn	Packing size
CFL001-D258-100-150/7XX	100W	15000lm	6500K	258×124mm	1PCS	280×280×160mm
CFL001-D258-100-170/7XX	100W	17000lm	6500K	258×124mm	1PCS	280×280×160mm
CFL001-D298-150-150/7XX	150W	22500lm	6500K	298×124mm	1PCS	320×320×160mm
CFL001-D298-150-170/7XX	150W	25500lm	6500K	298×124mm	1PCS	320×320×160mm
CFL001-D298-200-150/7XX	200W	30000lm	6500K	298×124mm	1PCS	320×320×160mm
CFL001-D298-200-170/7XX	200W	34000lm	6500K	298×124mm	1PCS	320×320×160mm
CFL001V-D258-100-150/8XX	100W	15000lm	6500K	258×128mm	1PCS	280×280×160mm
CFL001V-D298-150-150/8XX	150W	22500lm	6500K	298×128mm	1PCS	320×320×160mm
CFL001V-D298-200-150/8XX	200W	30000lm	6500K	298×128mm	1PCS	320×320×160mm

Attention: The lumen tolerance is ± 10%.

# GM-HL IP65 Horticulture Light(HL)



IP65 CB CE 

## General characteristics:

1. Use full spectrum 2835 module.
2. The heat generated by LED plant growth fill light is less, which can avoid plant burn. Because the heat generated is less, it can be used closer to plants, improve the utilization of light, and reduce the environmental temperature.
3. Installation: Hanging or ceiling.

## Applications recommendation:

It is suitable for plants such as tomato, cucumber, pepper and rose; it is used for indoor and outdoor lighting with short time and insufficient light

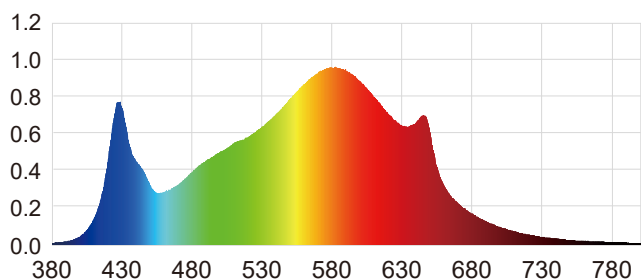

Type	Power	PPF(umol/s)	PPE(umol/s/W)	Dimensions(L×W×H)	Q'ty/ctn	Packing size
VE112GM-HL	36W	76	2.1	1191×70×69mm	12PCS	1240×327×242mm

Attention: The lumen tolerance is  $\pm 10\%$ .

# LED Horticultural Light





# GI-HL IP65 Horticulture Light(HL)



IP65 CB CE 

## General characteristics:

1. Use full spectrum 2835 module.
2. The heat generated by LED plant growth fill light is less, which can avoid plant burn. Because the heat generated is less, it can be used closer to plants, improve the utilization of light, and reduce the environmental temperature.
3. Installation: Hanging or ceiling.

## Applications recommendation:

It is suitable for plants such as tomato, cucumber, pepper and rose; it is used for indoor and outdoor lighting with short time and insufficient light.

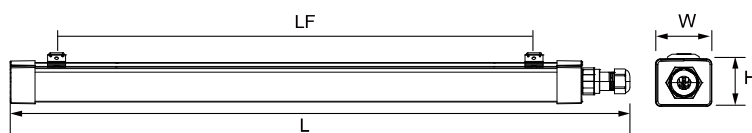
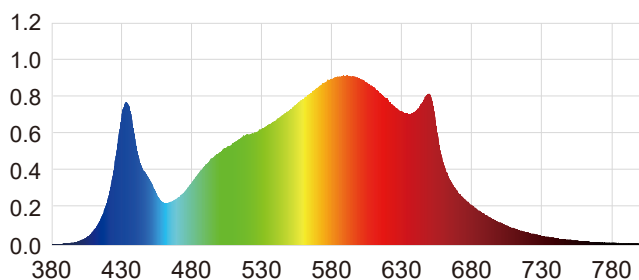

Type	Power	PPF(umol/s)	PPE(umol/s/W)	Dimensions(L×W×H)	Q'ty/ctn	Packing size
VE112GI-HL	28W	59	2.1	1267×53×46mm	15PCS	1342×185×269mm

Attention: The lumen tolerance is  $\pm 10\%$ .



# HL-T IP65 Horticulture Light(HL)

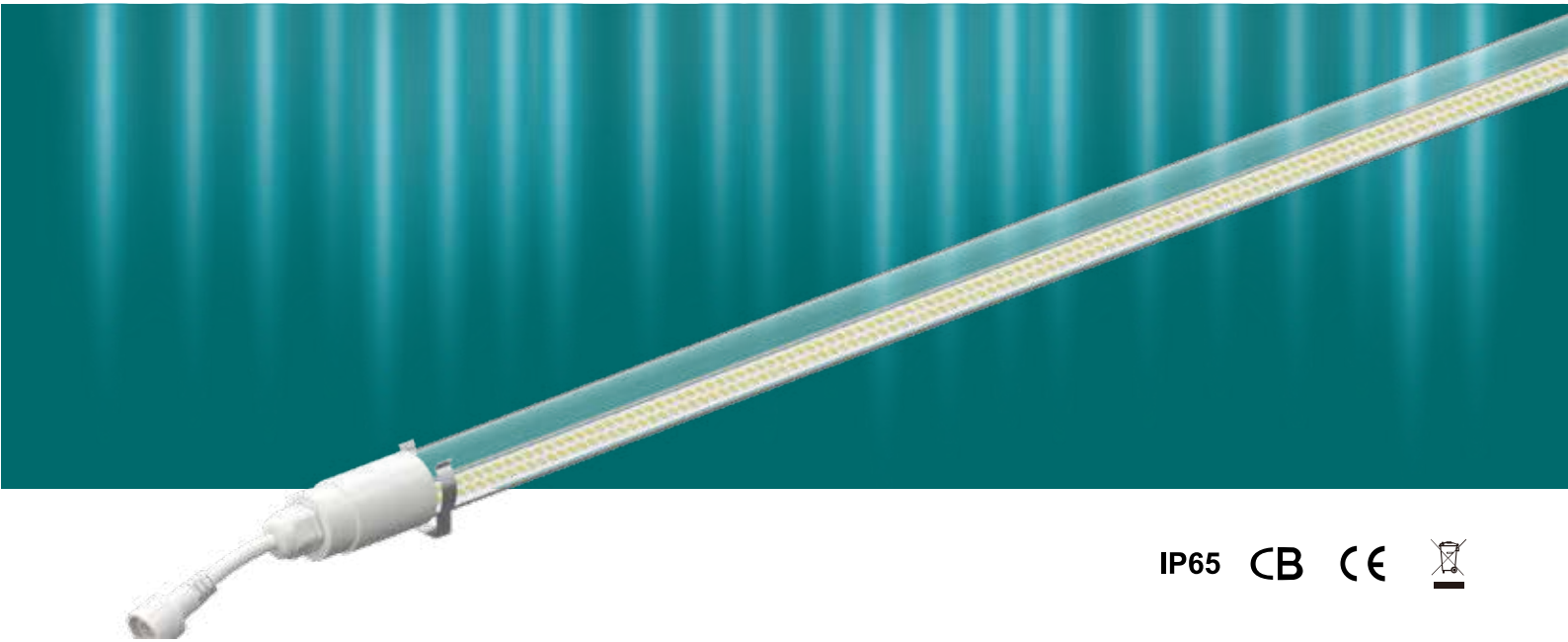

IP65 CB CE 

## General characteristics:

1. Use full spectrum 2835 module.
2. The heat generated by LED plant growth fill light is less, which can avoid plant burn. Because the heat generated is less, it can be used closer to plants, improve the utilization of light, and reduce the environmental temperature.
3. Installation: Hanging or ceiling.

## Applications recommendation:

It is suitable for plants such as tomato, cucumber, pepper and rose; it is used for indoor and outdoor lighting with short time and insufficient light.

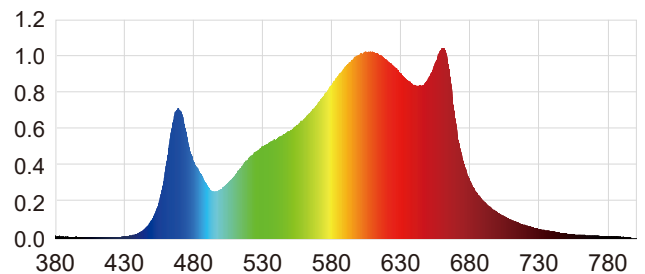
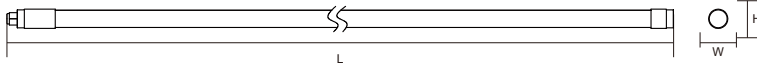

Type	Power	PPF(umol/s)	PPE(umol/s/W)	Dimensions(L×W×H)	Q'ty/ctn	Packing size
HL-T	20W	48	2.35	902×28×28mm	50PCS	1045×330×170mm
HL-T	30W	71	2.45	1790×28×28mm	40PCS	1900×262×152mm

Attention: The lumen tolerance is  $\pm 10\%$ .

# HL-01V Horticulture Light(HL)

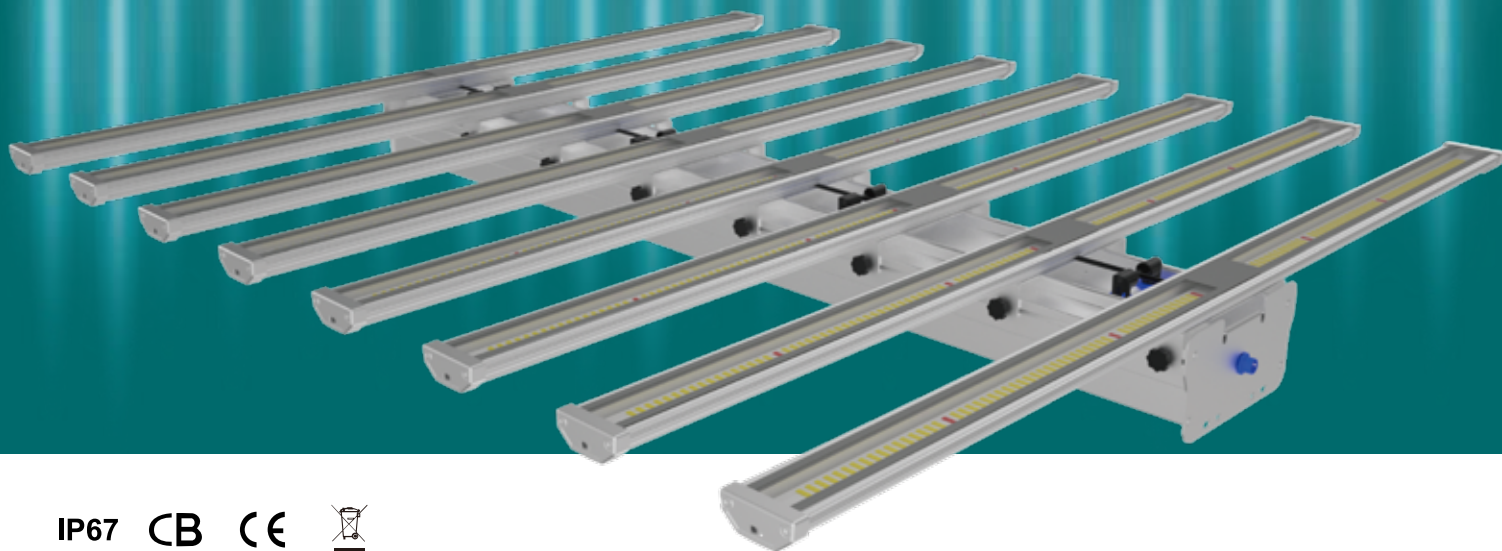

IP67 CB CE 

## General characteristics:

- 1.All adopt superior stainless steel nuts.
- 2.Die-casting shell brings perfect heat dissipation,Simple&perfect appearance.
- 3.Aluminum PCB with high thermal conductivity as chip carrier for faster cooling.
- 4.Energy-efficient,about double to triple of the metal lamp or the sodium lamp.
- 5.Led grow light generates less heat, avoids the damage to plant caused by generated high temperature, could use more closer to plant, improves the utilization rate of light,and reduces ambient temperature.
- 6.Tear open outfit is convenient.

## Applications recommendation:

Use in supplement light for plant growth, suitable for tomato, cucumber, pepper,cannabis, rose and other plant, application in indoor supplement light,the place with short outdoor lighting time and insufficient light.

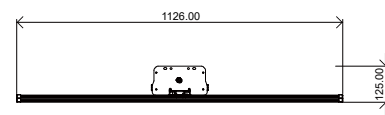
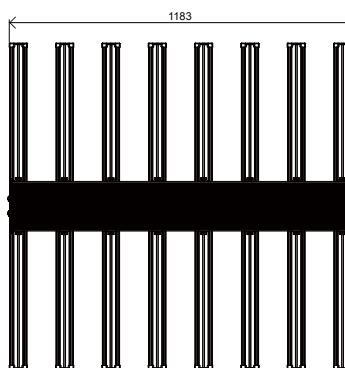
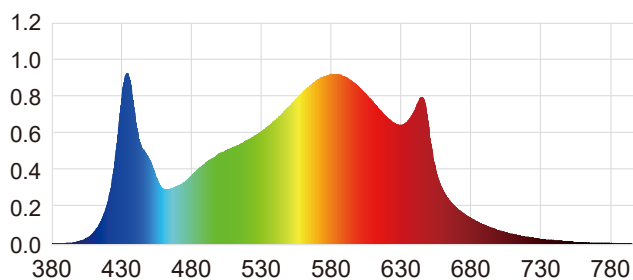

Type	Power	PPF(umol/s)	PPE(umol/s/W)	Dimensions(L×W×H)	Q'ty/ctn	Packing size
HL-01V-A8_640w	640W	1959	3.1	1183*1126*125mm	1	1255*302*126mm

Attension: The lumen tolerance is ± 10%.



# LED Horticultural Light



# HL-02V Horticulture Light(HL)

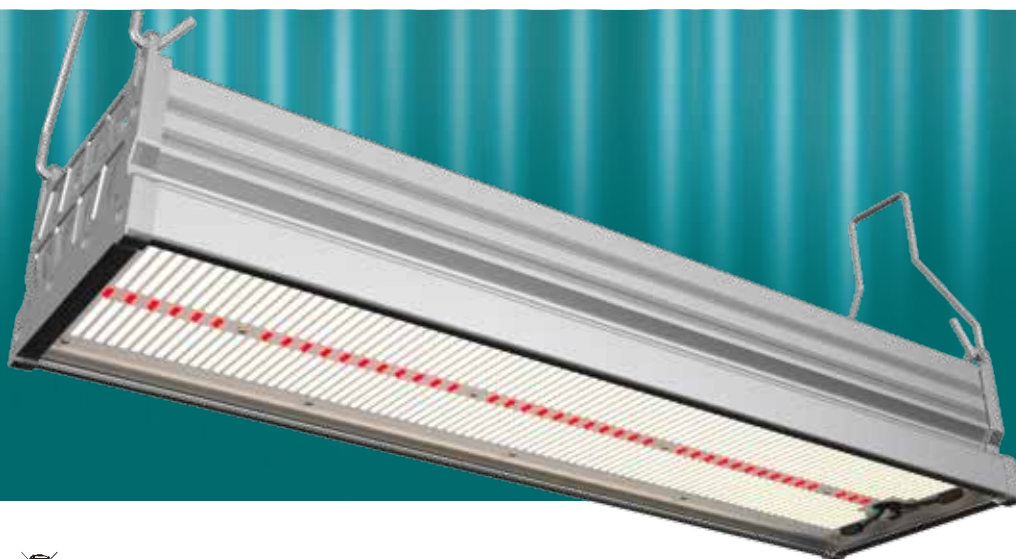

IP67 CB CE 

## General characteristics:

- 1.All adopt superior stainless steel nuts.
- 2.Die-casting shell brings perfect heat dissipation,Simple&perfect appearance.
- 3.Aluminum PCB with high thermal conductivity as chip carrier for faster cooling.
- 4.Energy-efficient,about double to triple of the metal lamp or the sodium lamp.
- 5.Led grow light generates less heat, avoids the damage to plant caused by generated high temperature, could use more closer to plant, improves the utilization rate of light,and reduces ambient temperature.
- 6.Tear open outfit is convenient.

## Applications recommendation:

Use in supplement light for plant growth, suitable for tomato, cucumber, pepper,cannabis, rose and other plant, application in indoor supplement light,the place with short outdoor lighting time and insufficient light.

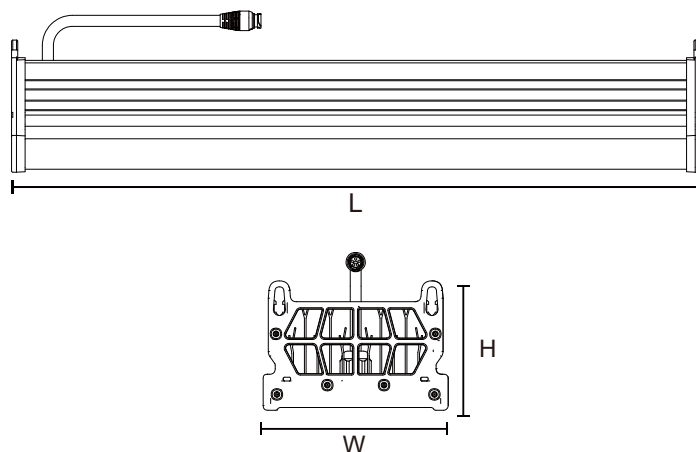
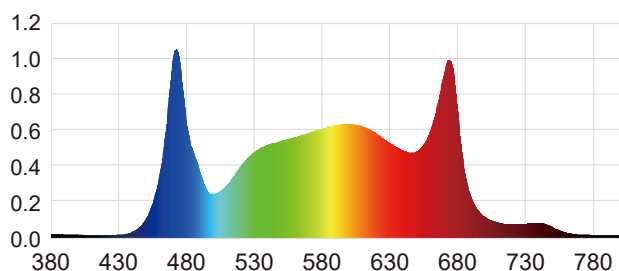

Type	Power	PPF(umol/s)	PPE(umol/s/W)	Dimensions(L×W×H)	Q'ty/ctn	Packing size
HL-02V-A1	320W	980	3.0	558*153.5*107.4(mm)	1	615*200*129(mm)

Attension: The lumen tolerance is ± 10%.



# HL-02V Horticulture Light(HL)

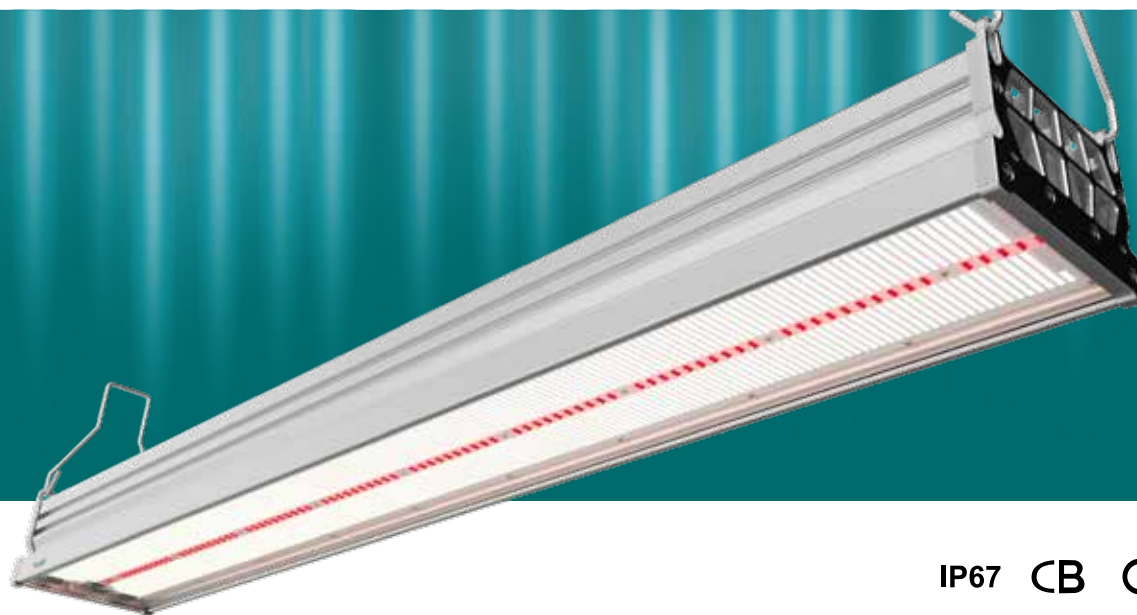

IP67 CB CE 

## General characteristics:

- 1.All adopt superior stainless steel nuts.
- 2.Die-casting shell brings perfect heat dissipation,Simple&perfect appearance.
- 3.Aluminum PCB with high thermal conductivity as chip carrier for faster cooling.
- 4.Energy-efficient,about double to triple of the metal lamp or the sodium lamp.
- 5.Led grow light generates less heat, avoids the damage to plant caused by generated high temperature, could use more closer to plant, improves the utilization rate of light,and reduces ambient temperature.
- 6.Tear open outfit is convenient.

## Applications recommendation:

Use in supplement light for plant growth, suitable for tomato, cucumber, pepper,cannabis, rose and other plant, application in indoor supplement light,the place with short outdoor lighting time and insufficient light.

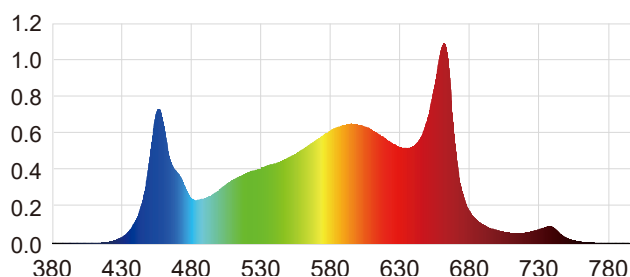
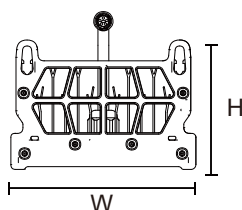

Type	Power	PPF(umol/s)	PPE(umol/s/W)	Dimensions(L×W×H)	Q'ty/ctn	Packing size
HL-02V-A1	640W	1813	2.93	1108*153.5*107.4(mm)	1	1165*200*129(mm)

Attention: The lumen tolerance is  $\pm 10\%$ .

# HL-04V Horticulture Light(HL)



IP67 CB CE 

## General characteristics:

- 1.All adopt superior stainless steel nuts.。
- 2.Die-casting shell brings perfect heat dissipation,Simple&perfect appearance.
- 3.Aluminum PCB with high thermal conductivity as chip carrier for faster cooling.
- 4.Energy-efficient,about double to triple of the metal lamp or the sodium lamp.
- 5.Led grow light generates less heat, avoids the damage to plant caused by generated high temperature, could use more closer to plant, improves the utilization rate of light,and reduces ambient temperature.
- 6.Tear open outfit is convenient.

## Applications recommendation:

Use in supplement light for plant growth, suitable for tomato, cucumber, pepper, cannabis, rose and other plant, application in indoor supplement light, the place

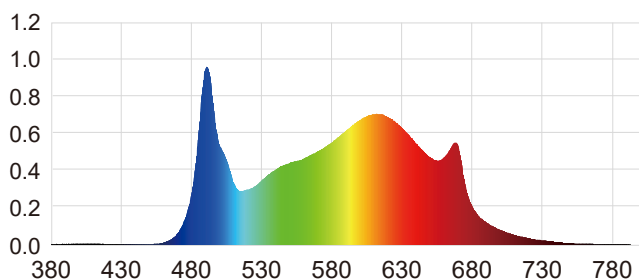
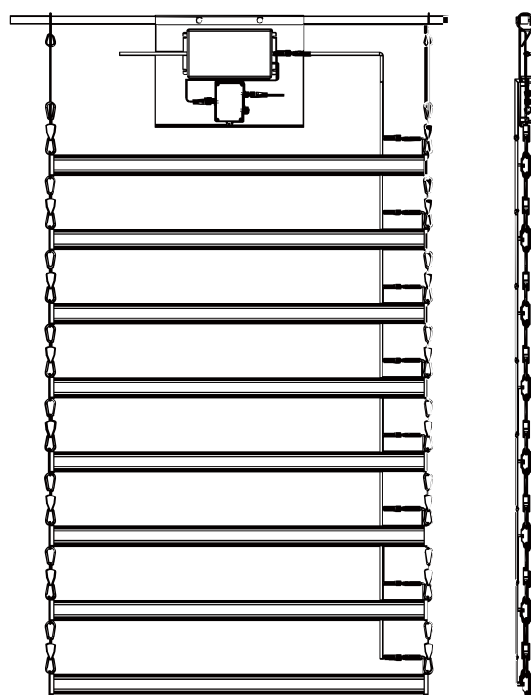

Type	Power	PPF(umol/s)	PPE(umol/s/W)	Dimensions(L×W×H)	Q'ty/ctn	Packing size
HL-04V-A8_640w	640W	1959	3.1	2000*1125*40mm	1	1285*182*159mm

Attention: The lumen tolerance is ± 10%.

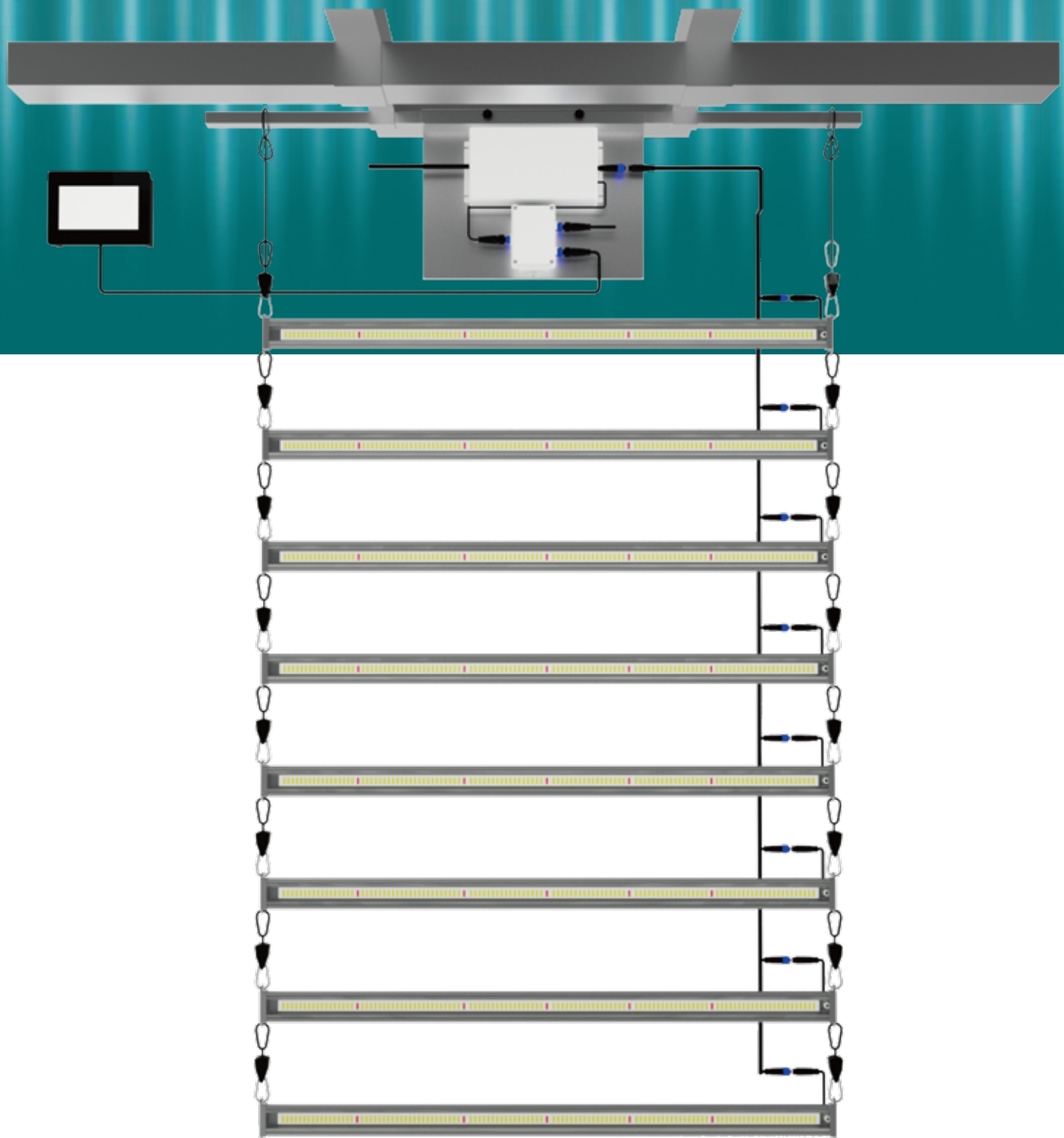

# VE24A Waterproof connectos series

VE-24A



VE-24A-01



VE-24A-02



VE-24A-03



VE-24A-04



## FEATURES & ADVANTAGES:

- 1.Flammability class PA66,protection level IP66;
- 2.Integrates wiring terminal into a waterproof instant cap coupler;
- 3.Improves convenience of instant external wiring,no need to open the housing;
- 4Simply wire the single core cable by plugging into the hole,no need any additiond tools;
- 5.Apply to hard wire.

## APPLICABLE DEVICES:

IP65 waterproof light fixtures

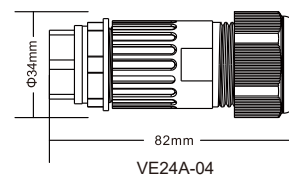
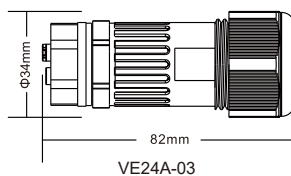
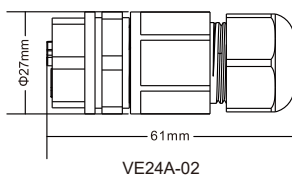
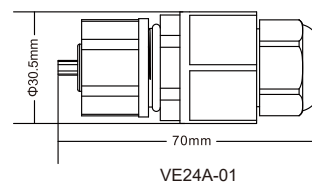
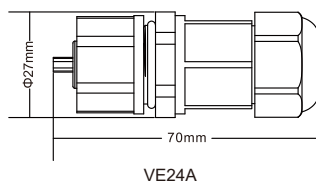

Type	Protection level	Applicable wire diameter	Number of cores	Nominal voltage	Rated current	Puncture voltage	Mounting hole diameter
VE24A	IP66	0.75mm 2-2.5mm <sup>2</sup>	1,2,3	AC 0-450V	0-24A	≤ 4000V	20mm
VE24A-01	IP66	0.75mm <sup>2</sup> -2.5mm <sup>2</sup>	1,2,3	AC 0-450V	0-24A	≤ 4000V	20mm
VE24A-02	IP66	0.75mm <sup>2</sup> -2.5mm <sup>2</sup>	1,2,3	AC 0-450V	0-6A	≤ 4000V	20mm
VE24A-03	IP66	0.75mm <sup>2</sup> -2.5mm <sup>2</sup>	1,2,3,4	AC 0-450V	0-6A	≤ 4000V	20mm
VE24A-04	IP66	0.75mm <sup>2</sup> -2.5mm <sup>2</sup>	1,2,3,4,5	AC 0-450V	0-6A	≤ 4000V	20mm



# VE24B Waterproof connectos series

VE-24B-02

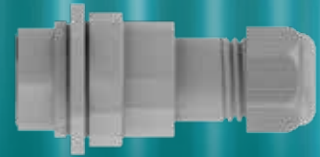

VE-24B-03

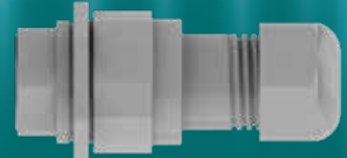
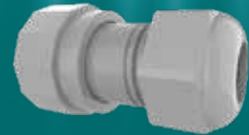

## FEATURES & ADVANTAGES:

- 1.Flammability class PA66,protection level IP66;
- 2.Integrates wiring terminal into a waterproof instant cap coupler;
- 3.Improves convenience of instant external wiring,no need to open the housing;
- 4Simply wire the single core cable by plugging into the hole,no need any additiond tools;
- 5.Apply to hard wire.

## APPLICABLE DEVICES:

IP65 waterproof light fixtures

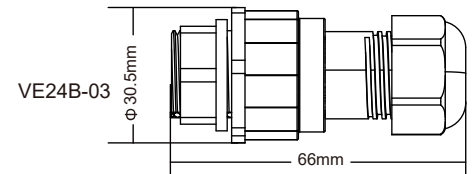
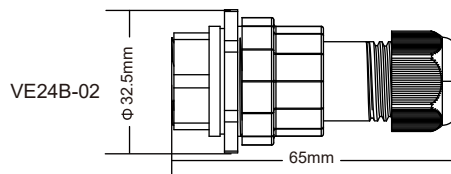

Type	Protection level	Applicable wire diameter	Number of cores	Nominal voltage	Rated current	Puncture voltage	Mounting hole diameter
VE24B-02	IP66	0.75mm <sup>2</sup> -2.5mm <sup>2</sup>	1,2	AC 0-450V	0-6A	≤ 4000V	20mm
VE24B-03	IP66	0.75mm <sup>2</sup> -2.5mm <sup>2</sup>	1,2,3	AC 0-450V	0-6A	≤ 4000V	20mm

# VE24C Waterproof connectos series

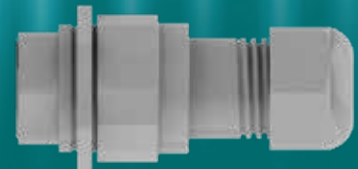
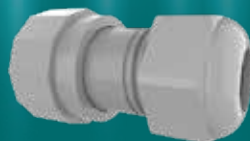

## FEATURES & ADVANTAGES:

- 1.Flammability class PA66,protection level IP66;
- 2.Integrates wiring terminal into a waterproof instant cap coupler;
- 3.Improves convenience of instant external wiring,no need to open the housing;
- 4Simply wire the single core cable by plugging into the hole,no need any additiond tools;
- 5.Apply to hard wire.

## APPLICABLE DEVICES:

IP65 waterproof light fixtures

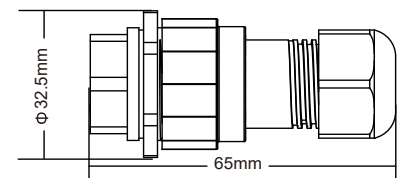

Type	Protection level	Applicable wire diameter	Number of cores	Nominal voltage	Rated current	Puncture voltage	Mounting hole diameter
VE24C-02	IP66	0.75mm <sup>2</sup> -2.5mm <sup>2</sup>	1,2	AC 0-450V	0-6A	≤ 4000V	20mm