

WOD[®]

**YUHUAN WOD
AUTO PARTS CO.,LTD**

WOD[®] 沃顿

玉环沃顿汽车零部件有限公司
YUHUAN WOD AUTO PARTS CO.,LTD

地址：浙江省玉环县坎门科技工业园区
Add: Technological industrial zone, Yuhuan, Zhejiang, China
电话Tel: 0086-576-87130830
传真Fax: 0086-576-87130829
邮箱E-mail: james@wodrubber.com albee@wodrubber.com

www.lpprubber.com



COMPANY INTRODUCTION

企业简介

Yuhuan WOD Auto Parts Co.,Ltd. founded in 2008, persist on Integrity, Modesty, Efficient and Stability, is a manufactory which include production, sales and services .supply OEM and Aftermarket service for global automotive manufacturing enterprise .

Our company located in Yuhuan island which is the China Auto&Motor Parts Manufacturing base . with workshop area 3000 square meters .more than 50 employees. specialized in manufacturing Auto C.V Joint ,Steering Boot, Suspension Bushing , Stabilizer Bushing ,Strut Mount , Stabilizer Link and other rubber parts which cover all kinds of automotive brand ,Our products export to American ,South American The Middle East ,Asian. Europe and other country or area ,winning higher honors .

Our company follow the principle :Quality first ,Delivery on time . in order to improve the production efficiency ,We purchased the advanced equipment, hired the professional technical personnel .can meet all kinds of reasonable delivery requirement . Now our company have the yearly capacity include: Rubber Boot 3 Million pieces ,Bushing 2 Million pieces ,other rubber parts 300,000 pieces .

On quality control, Our company introduced the advanced rubber mixing technology and formula from Taiwan and Malaysia, absorb and improve. simultaneous we build our own Testing Laboratory ,have a full set of Testing equipment which include Tensile Testing Machine, High-Low Temperature Testing Chamber, Universal Fatigue Testing Machine, Ozone Testing Chamber, Heat Aging Testing Chamber, Image Measuring Instrument and No Rotor Rheometer . Use first inspection , casual inspection and full inspection to guarantee our quality .Our company passed the TS16949 authenticate and has maintained it ever since .

In future, we will follow the development strategy on technological innovation, continuous improvement, teamwork, total involvement, harmonious and honest ,customer satisfaction . constantly improve, steadily forward!

玉环沃顿汽车零部件有限公司，自2008年成立以来，一直秉承“诚信，谦虚，高效，稳定”的服务宗旨，为全世界汽车厂商提供售后和配套，是一家集生产，销售和服务为一体的汽车零部件制造企业！

公司坐落于“中国汽摩配制造基地”---浙江玉环，拥有厂房面积3000平方米，员工50人。专业生产汽车球笼防尘罩，转向器防尘罩，悬架衬套，稳定杆衬套，减震器顶胶，平衡杆以及其他各类橡胶制品。涉及车系包括美系、日系、欧系、韩系等世界大多数汽车品名。产品远销美国、南美、中东、欧洲等国家或地区并取得了良好的声誉。

公司遵循“质量第一、准时交货”的原则，购置了先进的设备，聘请了专业的技术人才，提高生产效率，满足客户的各种交货要求。目前公司的年生产能力分别为：防尘罩300万只，衬套200万只，其他橡胶类产品30万只。

在质量控制方面，公司从台湾、马来西亚引进了先进的炼胶技术及配方并不断自行消化改良，同时构建了自己的检测实验室，拥有包括拉力试验机，高低温试验箱，万能疲劳试验机，臭氧试验箱，热老化试验箱，影像测量仪，无转子硫化仪等一整套完善的检测设备。通过首检、抽检、全检等方式对公司生产的产品进行全方位的质量保障。我公司自2015年初通过了TS16949质量认证，并一直维持至今。

未来，公司将依靠“技术创新，持续改进，团队合作，全员参与，诚信和谐，顾客满意”的发展策略，不断提高，稳步向前！

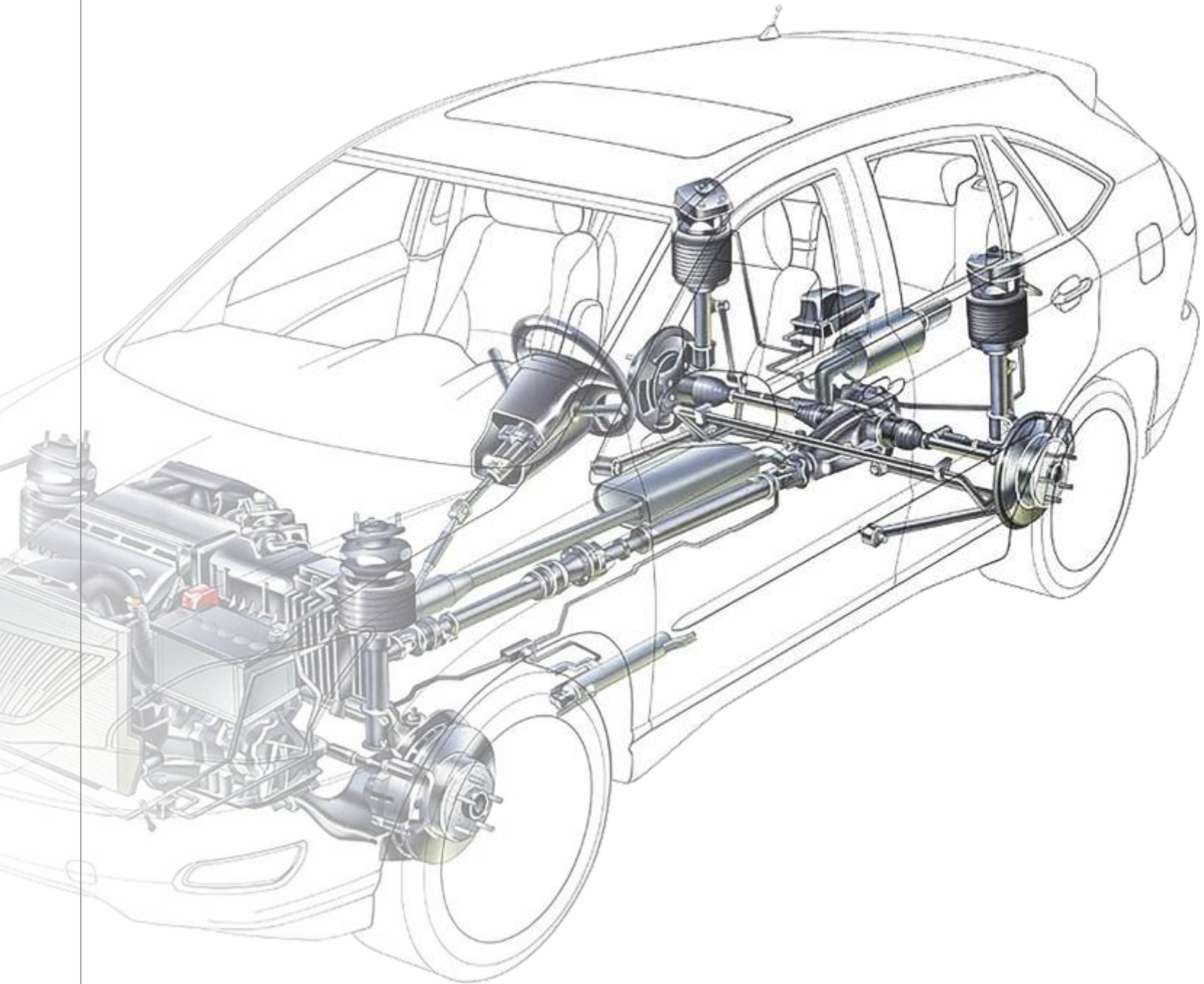



VULCANIZING WORKSHOP
 硫化车间



PACKAGING WORKSHOP
 包装车间



PRESS WORKSHOP
 冲压车间

Until now, WOD have 600 kinds of Rubber Boot mould, 400 kinds of Bushing mould, and more than 200 kinds of other rubber parts mould. Also we will develop all kinds of rubber parts mould according to client's Drawing and Sample.

目前公司拥有防尘罩模具600副，衬套模具400副以及其他各类橡胶件模具200余副同时我公司也能根据客户的图纸及样品开发各种汽车橡胶类零部件



MOULD MANAGEMENT
 模具管理

TESTING LABORATORY

检测实验室

热老化试验箱 Heat Aging Testing Chamber

胶料 RUBBER	温度 TEMPERATURE	时间 TIME	判断方法 JUDGEMENT METHOD
氯丁橡胶 CR	100°C	72Hours	出箱后测试硬度与拉伸强度 Test the Hardness and Tensile Strength after Heat Aging
丁腈橡胶 NBR	100°C	72Hours	出箱后测试硬度与拉伸强度 Test the Hardness and Tensile Strength after Heat Aging



耐臭氧试验箱 Ozone Testing Chamber

胶料 RUBBER	温度 TEMPERATURE	浓度 CONCENTRATION	时间 TIME	判断方法 JUDGEMENT METHOD
丁腈橡胶 NBR	40°C	50 PPHM	72Hours	出箱后目测 Visual after Ozone Testing
氯丁橡胶 CR	40°C	200 PPHM	72Hours	出箱后目测 Visual after Ozone Testing
天然橡胶 NR	40°C	200 PPHM	72Hours	出箱后目测 Visual after Ozone Testing



高低温试验箱 High-Low Temperature Testing Chamber

胶料 RUBBER	温度 TEMPERATURE	时间 TIME	判断方法 JUDGEMENT METHOD
氯丁橡胶 CR	-40°C	48Hours	出箱后目测 Visual after High-Low Temperature Testing
	120°C		
丁腈橡胶 NBR	-30°C	24Hours	出箱后目测 Visual after High-Low Temperature Testing
	120°C		



BUSHING FATIGUE TESTING MACHINE
 衬套疲劳试验机
TENSILE TESTING MACHINE
 拉力试验机
IMAGE MEASURING INSTRUMENT
 影像测量仪



**COMPANY
QUALIFICATION**

企业资质



Seek For Perfection

The pursuit of technical and management innovation is our fundamental of continuous development

精益求精 追求技术上，管理上的不断创新是我们不断发展的根本

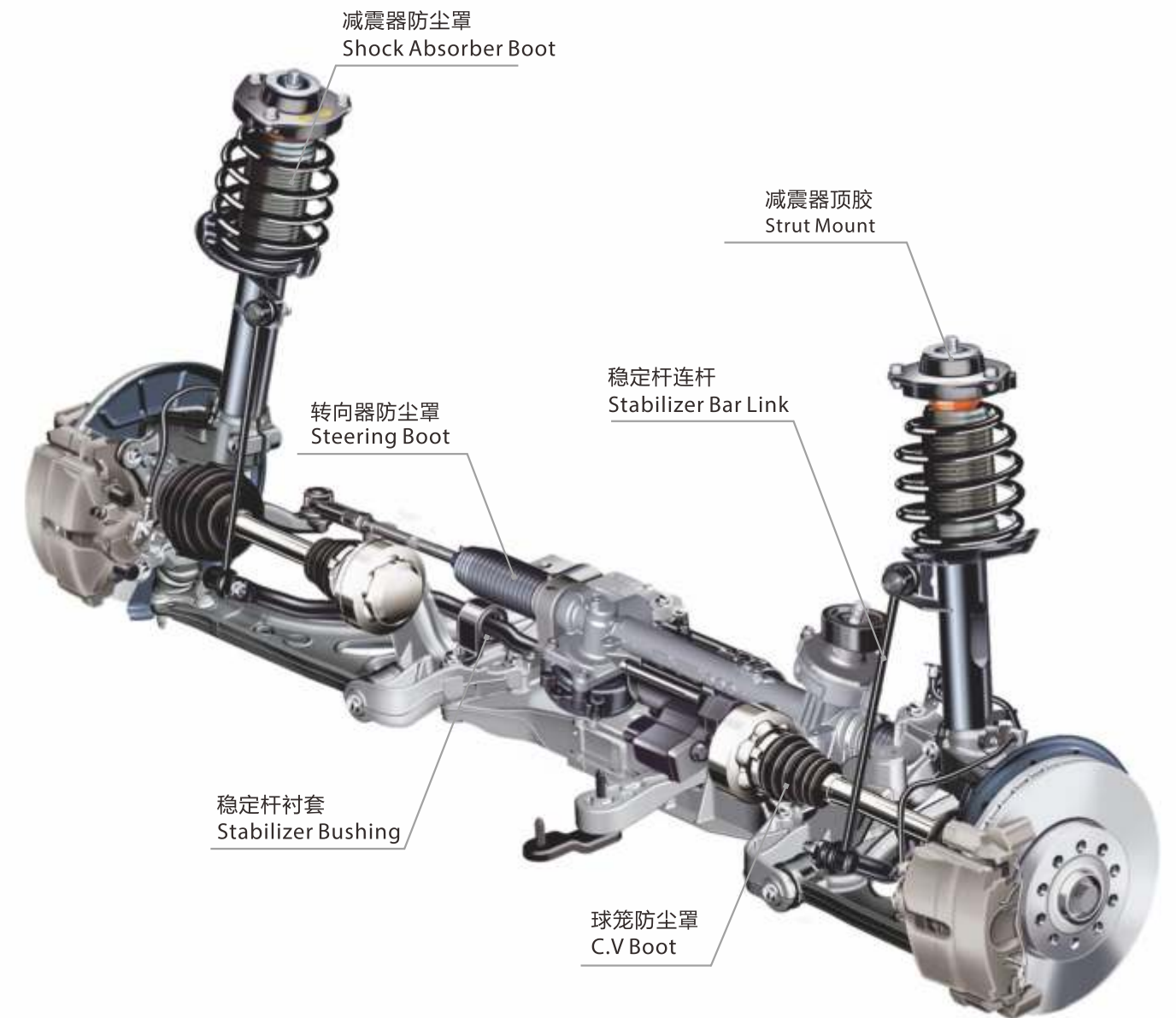

DISTRIBUTION

沃顿产品位置分布图

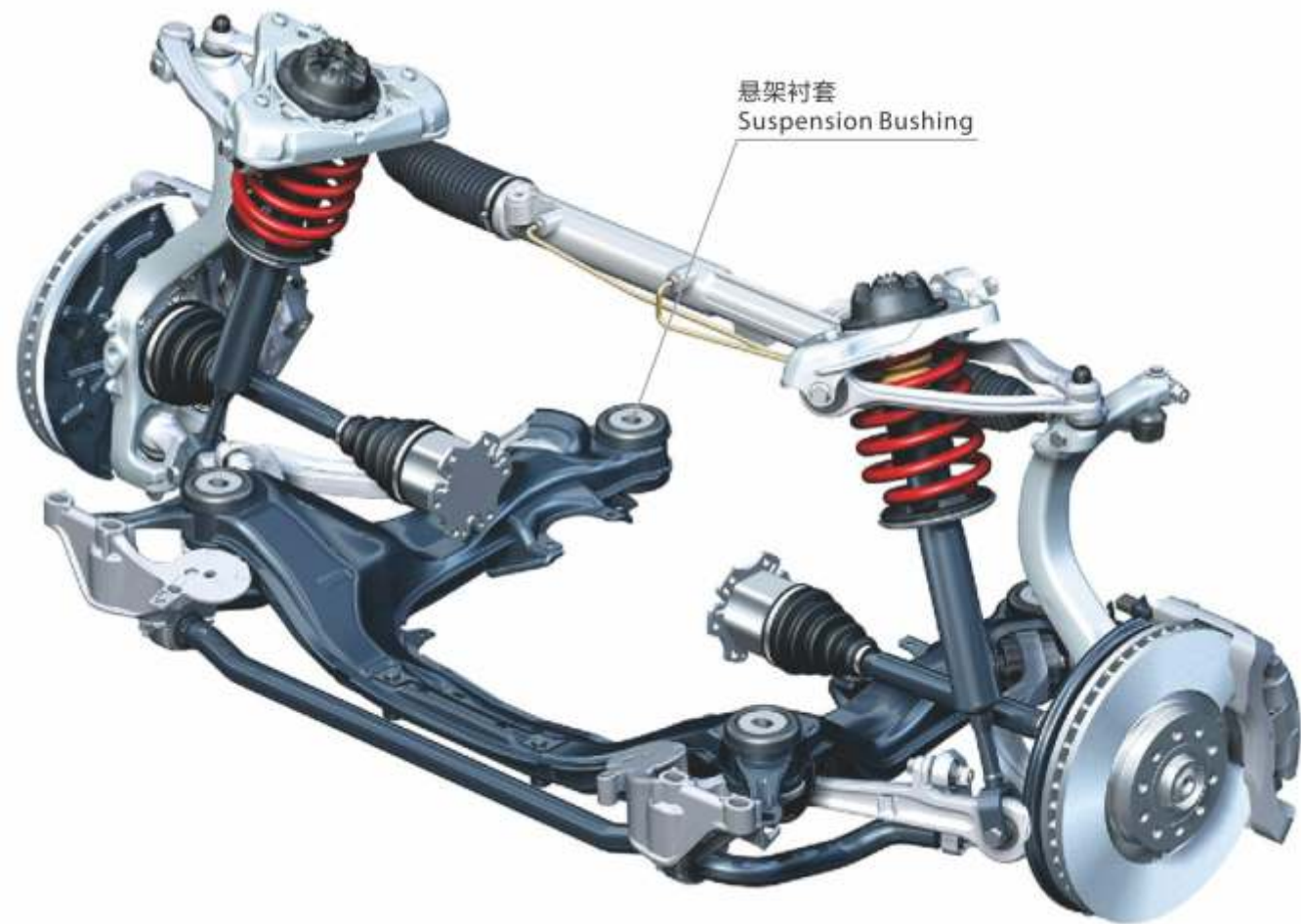

DISTRIBUTION

沃顿产品位置分布图

C.V BOOT

When the car run on the road, the C.V Joint will be rotating at a high speed, The C.V Joint Grease will be injected to lubricate the part and extend the service life .C.V Boot assemble on the C.V joint to prevent the grease leakage and stop the dust .it's a very important component part on C.V joint .

球笼防尘罩

汽车在行驶中，等速万向节在高速转动的情况下，需要在球笼内部注入球笼油脂，以便使设备润滑，延长使用寿命。防尘罩则装配在球笼上面，通过卡环等固定住，防止球笼油脂渗漏，并起到防止灰尘进入球笼内部的作用。是非常关键的等速万向节组成部件。



STEERING BOOT

This is a very important component part on Steering apparatus .can prevent the grease leakage and stop the dust.

转向器防尘罩

这是汽车转向装置上面的一个重要组成部件，防止转向器内部油脂渗漏，并防止灰尘进入。



SHOCK ABSORBER BOOT

This is a very important component part on Shock Absorber .can prevent the grease leakage and stop the dust. extend the service life

减震器防尘罩

这是汽车减震器上面的一个重要组成部件，防止减震器内部油脂渗漏，并防止灰尘进入，提高减震器寿命

SUSPENSION BUSHING

Under keep the vibration isolation performance on low-frequency section. The rubber component can help suspension system improve the vibration isolation performance on high-frequency section, insulate the high frequency inherent vibration .reduce the noise on uneven ground. The Rubber Bushing with its unique property, can alleviate the vibration and shock on uneven ground, insure the handling stability. some especial rubber bushing also have the function like universal hinge .can help some auto parts avoid the bend and premature abrasion .

悬架衬套

在悬架系统中引入橡胶元件可以在几乎不改变低频段隔振特性的前提下，大大改善系统在高频段的隔振效果，有助于悬架系统隔离高频固有振动，降低路面不平度引起的车内噪声。

而橡胶衬套以其特有的性质，可以缓解从路面传来的振动及冲击，确保操纵稳定性。

有些橡胶衬套还兼有万能铰的功能，

可以避免一些零件在使用中承受弯矩和早期磨损。



STABILIZER BUSHING

Bushing in anti-roll bar system have the function of holding, locating, buffering, shock absorbing as well as de-noising, meanwhile special bushings can provide anti-roll bar system with additional torsional stiffness which may enhance suspension handing performance.

稳定杆衬套

稳定杆橡胶衬套具有支撑，定位，缓冲，吸振以及降噪的功能，同时特殊设计的衬套可为横向稳定杆提供额外的扭转刚度，有利于悬架操控性能的提高

SWAY BAR LINK

Fixation the sway bar ,and reduce the car body roll and improve the comfort.

连接杆

固定稳定杆，并一定程度上减轻稳定杆受到的作用力，减小车身发生侧倾和改善平顺性。



STABILIZER BAR LINK

The Stabilizer Bar Link is used in link the Stabilizer Bar and Shock Absorber .can enhance the Rolling Angle stiffness of Suspension, reduce the car body roll and improve the comfort.

稳定杆连杆

汽车稳定杆连杆一端与稳定杆末端连接，另一端通过螺栓与焊接在减震器外缸筒上的支架固定连接。与稳定杆一起可以提高悬架的侧倾角刚度，减小车身发生侧倾和改善平顺性



STRUT MOUNT

Strut Mount can support the Shock Absorber and effectively absorb and reduce the movement resistance, to meet the shock-proof and reduce the noise .improve the riding comfort.

减震器顶胶

减震器顶胶具有正确支撑减震器在车体上的位置的作用，同时有效吸收和减少路面传递到减震器的运动阻力，从而达到避震，降噪的作用，提高行车舒适性。

CLUTCH FORK

It's a very important component part on Clutch .can push the release bearing proceed axial movement, control the Active Dish and Driven Dish separate smoothly, to meet the separation and reunion effect.

离合器分离叉

为离合器上的重要组成部件，推动分离轴承做轴向运动,控制离合器主从动盘顺利分离,从而达到离合的效果。



CENTER BEARING SUPPORT

中心轴承支撑



DRIVE SHAFT COUPLING KIT

Usually used on SUV and truck. Connect the Driver Shaft and Rear Axle ,the Coupling kit also have the buffer and shock-proof function.

传动轴连接盘

一般应用于越野车、卡车等，用以连接传动轴与后桥，并起到缓冲，减振的作用。



适用于越野车
Applicable to SUV



适用于小型卡车，皮卡
Applicable to Pickup truck and medium-sized truck.

SHOCK ABSORBER BUMPER

减震器缓冲块



ENGINE MOUNTS

发动机支架



BOOT KIT

防尘罩配件

WOD company can produce and supply all kinds of
Clamp, Nylon cable ties, C.V Joint Grease which used
with Rubber Boot.

沃顿公司能够生产供应各种类型的卡箍，尼龙扎带以
及球笼油脂