

CARDS OF PRODUCTS

EXTERNAL SEWAGE SYSTEM

FITTINGS OF POLYPROPYLENE (PP)
FOR THE EXTERNAL SEWAGE SYSTEM
- STR 5 - 13

PIPES WITH POLY (VINYL CHLORIDE) FOAMED-
CORE PVC -U FOR EXTERNAL SEWAGE SYSTEM
- STR 14 - 17

ARMAKAN PVC -U SN 2 PIPES WITH STRUCTURAL WALL
FOR NON -PRESSURE SEWAGE SYSTEMS
-STR 18 - 20

BACKWATER GATE TYPE - 1 DN 110
- STR 21 - 24

www.armakan.pl

1. PRODUCT NAME

Fittings of polypropylene (PP) for the external sewage system of the diameter range: Ø110 – Ø200 mm.

2. PURPOSE AND FEATURES OF THE PRODUCT

PP fittings are intended for use in underground pressure-free drainage and sewerage, under the constructions of buildings and out of them, marked by the symbol of "UD".

The PP sewage system is characterized by high resistance to high temperatures (can be used at temperatures up to + 90 °C).

3. TECHNICAL SPECIFICATIONS

PN-EN 1852-1:2018-02 Plastics piping systems for non-pressure underground drainage and sewerage - Polypropylene (PP) – Part 1: Specifications for pipes, fitting and the system.

4. DECLARED PERFORMANCE

| Essential characteristics of the product for the intended use or uses | Declared performance |
|---|---|
| Mass flow rate (MFR) for the material | MFR(230/2.16) \leq 1.5 g/10 min. |
| Oxidation induction time (OIT) for the material | OIT \geq 8 min. (temperature 200 °C) |
| External appearance and the color | The external and internal surfaces of fittings and fittings should be smooth, clean, free of unevenness, scratches, impurities, the pores and any heterogeneity of the surface; fittings should be homogeneously colored in all cross section |
| Dimensions | according to table 1 and 2 |
| Impact resistance | No damage |
| Effect of heating | Around the point(s) of injection. traces of the cracks. delamination or blistering should not exceed 20% of the wall thickness. No part of the connect line should not be obtuse to a depth greater than 20% of the wall thickness. |
| Resistance of the system connections to cyclic high temperatures | No leaks |
| Tightness of the socket connections | No leaks during testing and after the test. the decrease in vacuum \leq 0.27 bar |

Table 1. Dimensions of fittings

| Nominal size DN/DO | Nominal outer diameter (d) _n [mm] | The average external diameter d _{em} [mm] | | The minimum wall thickness e _{min} [mm] |
|--------------------|--|--|----------------------|--|
| | | d _{em. min} | d _{em. max} | |
| 110 | 110 | 110.0 | 110.4 | 3.4 |
| 160 | 160 | 160.0 | 160.5 | 4.9 |
| 200 | 200 | 200.0 | 200.6 | 6.2 |

Table 2. Dimensions of the sockets. and the length of sockets and bare ends

| Nominal size DN/DO | Nominal outer diameter (d) _n [mm] | Socket | | | | | Bare end |
|--------------------|--|---------------------------|--------------------------|--------------------------|-----------------------|-----------------------|--------------------------|
| | | d _{sm. min} [mm] | e _{2. min} [mm] | e _{3. min} [mm] | A _{min} [mm] | C _{max} [mm] | l _{1. min} [mm] |
| 110 | 110 | 110.4 | 3.1 | 2.6 | 40 | 22 | 62 |
| 160 | 160 | 160.5 | 4.5 | 3.7 | 50 | 32 | 82 |
| 200 | 200 | 200.6 | 5.6 | 4.7 | 58 | 40 | 98 |

d_{sm, min} -the minimum average inside diameter of the socket

e_{2, min} -minimum thickness of the wall of the socket

e_{3, min} -minimum wall thickness in the groove zone

A_{min} -the minimum depth of the socket behind seal

C_{max} -the maximum depth of the sealing zone

l_{1, min} -the minimum length of the bare end

5. ASSORTMENT

FITTINGS OF POLYPROPYLENE (PP) FOR THE EXTERNAL SEWAGE SYSTEM

ELBOW

| Diameter DN/OD (mm) | Angle α (°) | Wall thickness (mm) | Z 1 (mm) | Z 2 (mm) | L 1 (mm) | L 2 (mm) |
|---------------------|--------------------|---------------------|----------|----------|----------|----------|
| 110 | 15 | 3,4 | 5 | 18 | 64 | 64 |
| 110 | 30 | 3,4 | 19 | 15 | 64 | 62 |
| 110 | 45 | 3,4 | 26 | 28 | 64 | 64 |
| 110 | 67,5 | 3,4 | 41 | 41 | 64 | 62 |
| 110 | 87,5 | 3,4 | 57 | 61 | 64 | 64 |
| 160 | 15 | 4,9 | 11 | 22 | 84 | 86 |
| 160 | 30 | 4,9 | 25 | 31 | 84 | 86 |
| 160 | 45 | 4,9 | 38 | 45 | 84 | 86 |
| 160 | 67,5 | 4,9 | 57 | 66 | 84 | 86 |
| 160 | 87,5 | 4,9 | 84 | 93 | 84 | 86 |
| 200 | 15 | 6,2 | 8 | 33 | 100 | 100 |
| 200 | 30 | 6,2 | 26 | 43 | 100 | 100 |
| 200 | 45 | 6,2 | 38 | 60 | 100 | 100 |
| 200 | 67,5 | 6,2 | 68 | 81 | 100 | 100 |
| 200 | 87,5 | 6,2 | 96 | 111 | 100 | 100 |

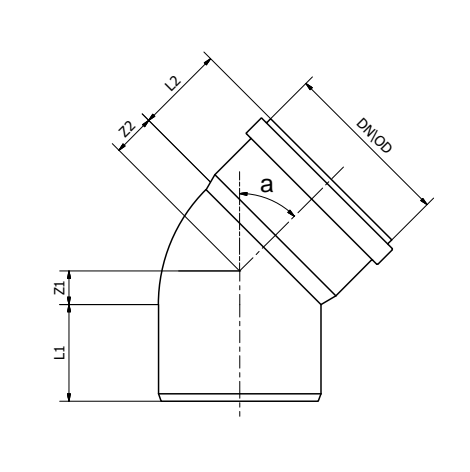
T-PIPE

| Diameter DN/OD (mm) | Diameter DN1/OD (mm) | Angle α (°) | Wall thickness (mm) | Z 1 (mm) | Z 2 (mm) | Z 3 (mm) | L 1 (mm) | L 2 (mm) | L 3 (mm) |
|---------------------|----------------------|--------------------|---------------------|----------|----------|----------|----------|----------|----------|
| 110 | 110 | 45 | 3,4 | 20 | 139 | 138 | 63 | 61 | 61 |
| 110 | 110 | 67,5 | 3,4 | 35 | 89 | 89 | 63 | 61 | 61 |
| 110 | 110 | 87,5 | 3,4 | 56 | 60 | 63 | 63 | 61 | 61 |
| 160 | 110 | 45 | 4,9 | 0 | 164 | 175 | 84 | 86 | 64 |
| 160 | 110 | 67,5 | 4,9 | 28 | 101 | 117 | 84 | 86 | 64 |
| 160 | 110 | 87,5 | 4,9 | 54 | 66 | 91 | 84 | 86 | 64 |
| 160 | 160 | 45 | 4,9 | 29 | 205 | 206 | 84 | 86 | 86 |
| 160 | 160 | 67,5 | 4,9 | 73 | 130 | 131 | 84 | 86 | 86 |
| 160 | 160 | 87,5 | 4,9 | 77 | 92 | 95 | 84 | 86 | 86 |
| 200 | 160 | 45 | 6,2 | 13 | 223 | 233 | 101 | 98 | 86 |
| 200 | 200 | 45 | 6,2 | 45 | 253 | 253 | 101 | 98 | 98 |
| 200 | 200 | 87,5 | 6,2 | 98 | 115 | 116 | 101 | 98 | 98 |

5. ASSORTMENT

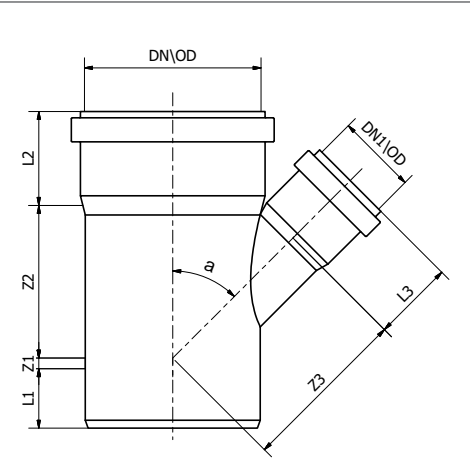
FITTINGS OF POLYPROPYLENE (PP) FOR THE EXTERNAL SEWAGE SYSTEM

● CROSS



| Diameter DN/OD (mm) | Diameter DN1/OD (mm) | Angle α (°) | Wall thickness (mm) | Z1 (mm) | Z2 (mm) | Z3 (mm) | L1 (mm) | L2 (mm) | L3 (mm) |
|---------------------|----------------------|--------------------|---------------------|---------|---------|---------|---------|---------|---------|
| 160 | 160 | 90 | 4,9 | 86 | 79 | 76 | 88 | 80 | 80 |

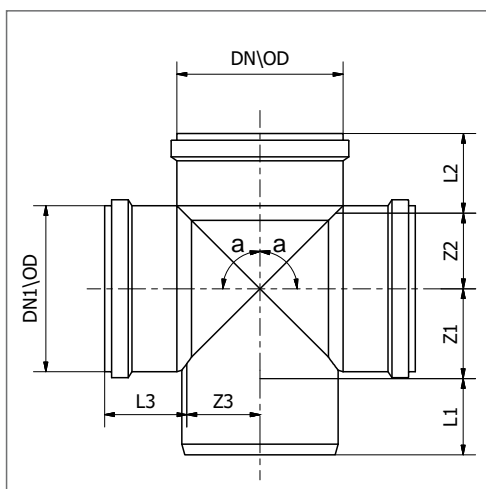

5. ASSORTMENT

FITTINGS OF POLYPROPYLENE (PP) FOR THE EXTERNAL SEWAGE SYSTEM

CLEANOUT

| Diameter DN/OD (mm) | Wall thickness (mm) | Z 1 (mm) | Z 2 (mm) | L 1 (mm) | L 2 (mm) | D1 (mm) |
|---------------------|---------------------|----------|----------|----------|----------|---------|
| 110 | 3,4 | 53 | 57 | 64 | 61 | 98 |
| 160 | 4,9 | 74 | 110 | 107 | 86 | 142 |

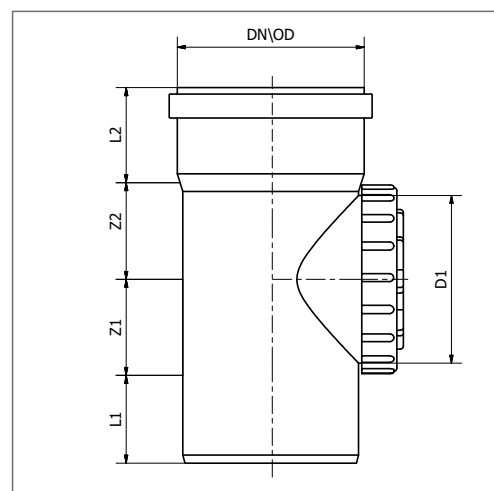

CLEANOUT WITH SEPARATOR

| Diameter DN/OD (mm) | Wall thickness (mm) | Z 1 (mm) | Z 2 (mm) | L 1 (mm) | L 2 (mm) | D1 (mm) |
|---------------------|---------------------|----------|----------|----------|----------|---------|
| 160 | 4,9 | 74 | 110 | 107 | 86 | 142 |

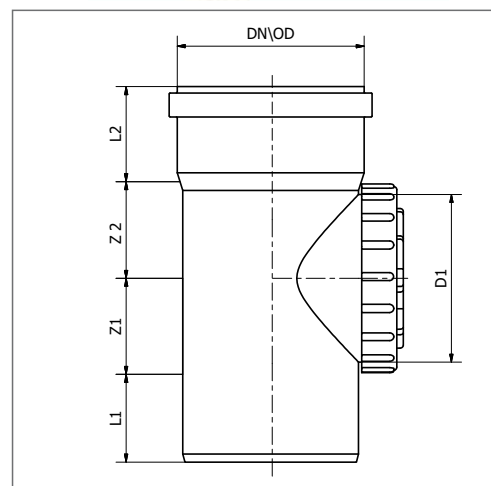

5. ASSORTMENT

FITTINGS OF POLYPROPYLENE (PP) FOR THE EXTERNAL SEWAGE SYSTEM

● REDUCER



| Diameter DN/OD (mm) | Diameter DN1/OD (mm) | Wall thickness (mm) | Z (mm) | L1 (mm) | L2 (mm) |
|---------------------|----------------------|---------------------|--------|---------|---------|
| 160 | 110 | 4,9 | 36 | 88 | 59 |
| 200 | 160 | 6,2 | 36 | 100 | 80 |

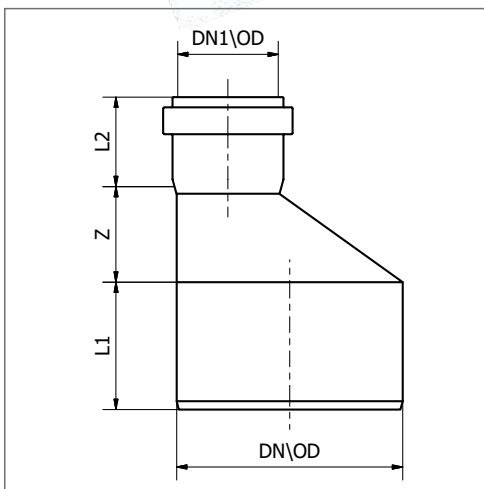

● SHORT REDUCER



| Diameter DN/OD (mm) | Diameter DN1/OD (mm) | Wall thickness (mm) | L (mm) | L1 (mm) | L2 (mm) |
|---------------------|----------------------|---------------------|--------|---------|---------|
| 160 | 110 | 4,9 | 188 | 88 | 61 |

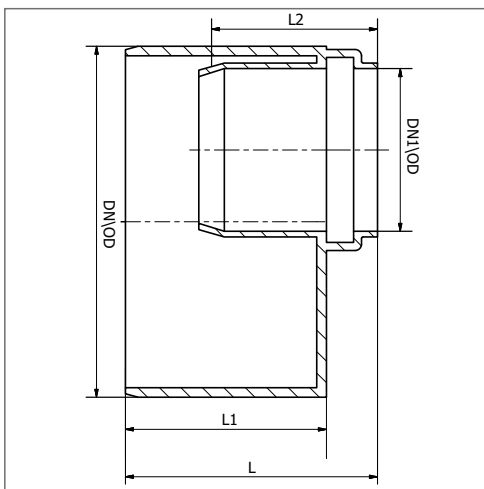

5. ASSORTMENT

FITTINGS OF POLYPROPYLENE (PP) FOR THE EXTERNAL SEWAGE SYSTEM

COUPLING ●

| Diameter DN/OD (mm) | Wall thickness (mm) | L (mm) | L1 (mm) |
|---------------------|---------------------|--------|---------|
| 110 | 3,4 | 130 | 63 |
| 160 | 4,9 | 180 | 87 |
| 200 | 6,2 | 217 | 106 |

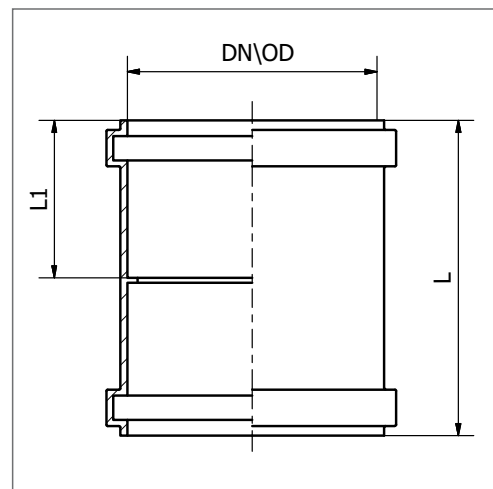

SLEEVE JOINT ●

| Diameter DN/OD (mm) | Wall thickness (mm) | L (mm) |
|---------------------|---------------------|--------|
| 110 | 3,4 | 130 |
| 160 | 4,9 | 180 |
| 200 | 6,2 | 255 |

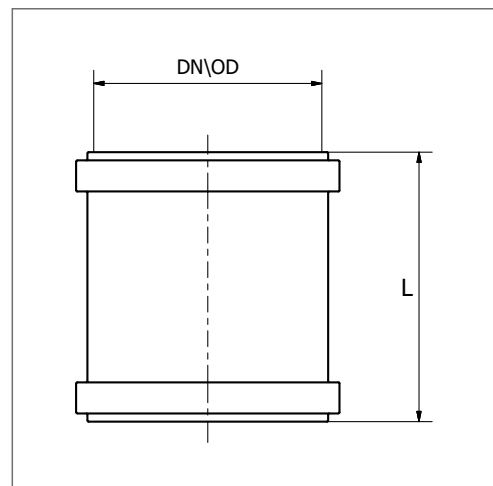

5. ASSORTMENT

FITTINGS OF POLYPROPYLENE (PP) FOR THE EXTERNAL SEWAGE SYSTEM

● PLUG

| Diameter DN/OD (mm) | Wall thickness (mm) | D 1 (mm) | L (mm) | L1 (mm) |
|---------------------|---------------------|----------|--------|---------|
| 110 | 3,4 | 124 | 61 | 57 |
| 160 | 4,9 | 171 | 60 | 56 |
| 200 | 6,2 | 210 | 64 | 59 |

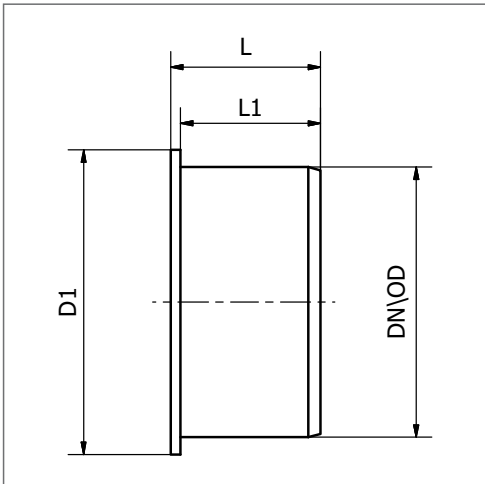

6. PACKING, STORAGE, TRANSPORT

6.1 PACKING

Fittings depending on the type and arrangements are packed in bags of various types and sizes, cartons or are tied together by using a string.

Often the packaging method depends on individual arrangements with a recipient.

6.2 STORAGE

Fittings should be protected against mechanical impacts that would lead to damage or lower functional properties.

Because these plastics have limited resistance to elevated temperature and ultraviolet radiation, longer storage of products should take place in roofed or enclosed spaces, to protect them against direct and excessive sunlight.

6.3 TRANSPORT

Avoid transporting fittings in bulk, together with other building materials, to avoid mechanical damage. Products should not be dropped and pulled on the ground but carried.

7. MARKING

The marking on the fittings includes:

- the company sign - the company logo - ARMAKAN PVC;
- trade name - e.g. KL (elbow), TR (T-pipe);
- type of material - PP;
- dimensions - diameter / angle (when it is present);
- S-series – S16;
- technical specification number – PN- EN 1852;
- application area symbol - "UD";
- construction mark together with the last two digits of the year, in which it was placed on the construction product for the first time
- production date - month and year.



8. SYSTEM INSTALLATION

When installing pipes and fittings, national and/or local requirements and technical regulations should be taken into account.

When assembling cup connections with an elastomer gasket, it is recommended to observe the following rules:

1. a bare end should be beveled;
2. bare ends of pipes should be cut at the construction site, they should be cut perpendicular and chamfered in the same way, like finished pipes and fittings supplied by F. P. H. U. "ARMAKAN" - PVC Kiebus Krzysztof;
3. bare ends, cups, and grooves for elastomer seals should be clean, and the gaskets should be properly placed;
4. only gaskets and lubricants supplied/recommended by the manufacturer of pipes and fittings should be used – F. P. H. U. "ARMAKAN" - PVC Kiebus Krzysztof;
5. The "SLIDER" sliding agent, which is used to facilitate the assembly and disassembly of plastic pipes and fittings, should be applied to the gasket and bare end of the pipe or fittings. This method significantly extends the service life of the gaskets. It is frost resistant and has the PZH attest (Państwowy Zakład Higieny - National Institute of Hygiene);
6. the bare ends should be axially aligned with the cups to be joined and inserted to the required depth.



9. GUARANTEE

The company provides sewage systems produced by it with the statutory warranty and guarantee for a period of 20 years from the date of sale under the following conditions:

1. proper transport, storage;
2. using the product for its intended purpose;
3. assembly of the sewage system, taking into account the specific requirements and relevant national regulations, guidelines for the implementation of the installation and technical regulations.

1. PRODUCT NAME

Pipes with poly (vinyl chloride) foamed core PVC - U for external sewage system of diameters range: Ø110 – Ø200 mm.

2. PURPOSE AND FEATURES OF THE PRODUCT

Pipes made with structural walls of non-plasticized poly (vinyl chloride) PVC-U for use in the underground pressure-free water drainage and sewage.

Area of application: the symbol "UD" (are intended for use in the underground outside the constructions of buildings and inside the building structure).

Elements of the PVC-U external sewage system can be used for non-pressure transport of sewage at a temperature of + 40 ° C or temporary + 60 ° C.

3. TECHNICAL SPECIFICATIONS

PN-EN 13476-2:2018-05 Plastics piping systems for non-pressure underground drainage and sewerage – Structured-wall piping systems of unplasticized poly(vinyl chloride) (PVC-U), polypropylene (PP) and polyethylene (PE)– Part 2: Specifications for pipes and fittings with smooth internal and external surface and the stem, type A.

4. DECLARED PERFORMANCE

| Essential characteristics of the product for the intended use or uses | Declared performance |
|---|--|
| External appearance and the color | Pipe surfaces should be smooth, clean and free of scratches, visible contaminations or pores, or any other surface heterogeneity; the colour of the pipes on the outside and the inside should be uniform in terms of hue and intensity (there might be a different tones); the inner and the outer layer of the pipes should be colored in the whole section of the wall. |
| Dimensions | according to table 1 and 2 |
| Temperature of softening temperature by Vicat [°C] | ≥ 79 |
| Resistance to dichloromethane | The lack of impact |
| Longitudinal shrinkage [%] | ≤ 5 no blisters, cracks and delamination |
| Peripheral stiffness [kN/m ²] | SN 4 ≥ 4 SN 8 ≥ 8 |
| Impact resistance [%] | TIR ≤ 10 |
| Peripheral flexibility | No cracks or delamination at 30% of the deflection of the outer diameter |
| Creep indicator | PVC-U: ≤ 2.5 in extrapolation for 2 years |
| The tightness of joints with elastomeric sealing ring | No leaks during testing and after the test, the decrease in vacuum ≤ 0.27 bar |

Table 1. Dimensions of the pipes

| Nominal size DN/DO | Nominal outer diameter (d) _n [mm] | The average external diameter d _{em} [mm] | | Wall thickness e [mm] | | | | Min. wall thickness of inner layer e _{4, min} [mm] |
|--------------------|--|--|-------|-----------------------|----------------------|------------------|------------------|---|
| | | | | SN 4 SDR41 | | SN 8 SDR 34 | | |
| | | | | d _{em, min} | d _{em, max} | e _{min} | e _{max} | |
| 110 | 110 | 110.0 | 110.3 | 3.2 | 3.8 | 3.2 | 3.8 | 0.4 |
| 160 | 160 | 160.0 | 160.4 | 4.0 | 4.6 | 4.7 | 5.4 | 0.5 |
| 200 | 200 | 200.0 | 200.5 | 4.9 | 5.6 | 5.9 | 6.7 | 0.6 |

Table 2. Dimensions of the sockets

| Nominal size DN/DO | Nominal external diameter d_n [mm] | Socket | | | | | | Bare end | | |
|--------------------|--------------------------------------|--------------------|-------------------|------|-------------------|------|----------------|----------------|-------------------|--------|
| | | $d_{sm, min}$ [mm] | $e_{2, min}$ [mm] | | $e_{3, min}$ [mm] | | A_{min} [mm] | C_{max} [mm] | $L_{1, min}$ [mm] | H [mm] |
| | | | SN 4 | SN 8 | SN 4 | SN 8 | | | | |
| 110 | 110 | 110.3 | 2.9 | 2.9 | 2.4 | 2.4 | 32 | 26 | 60 | 6 |
| 160 | 160 | 160.4 | 3.6 | 4.3 | 3.0 | 3.6 | 42 | 32 | 81 | 7 |
| 200 | 200 | 200.5 | 4.4 | 5.4 | 3.7 | 4.5 | 50 | 40 | 99 | 9 |

$d_{sm, min}$ -the minimum average inside diameter of the socket

$e_{2, min}$ -minimum thickness of the wall of the socket

$e_{3, min}$ -minimum wall thickness in the groove zone

A_{min} -the minimum depth of the cup behind seal

C_{max} -the maximum depth of the sealing zone

$L_{1, min}$ -the minimum length of the bare end

H – the length of the chamfer (approximate value)

5. ASSORTMENT

PIPES WITH POLY (VINYL CHLORIDE) FOAMED-CORE PVC-U FOR EXTERNAL SEWAGE SYSTEM

PIPES

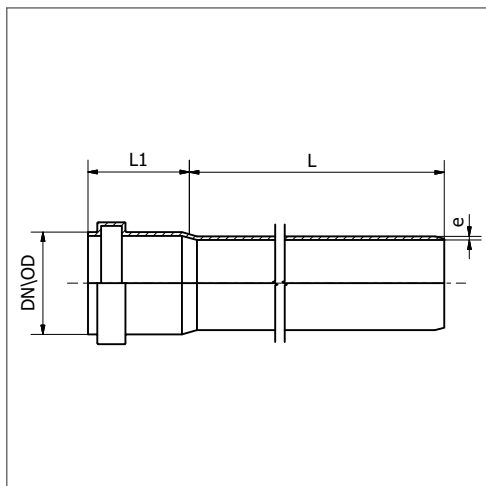

| Diameter DN/OD (mm) | Wall thickness e (mm) | L (mm) | L 1 (mm) | Peripheral stiffness (kN/m ²) |
|---------------------|-----------------------|--------|----------|---|
| 110 | 3,2 | 500 | 69 | SN 8 |
| 110 | 3,2 | 1000 | 69 | SN 8 |
| 110 | 3,2 | 2000 | 69 | SN 8 |
| 110 | 3,2 | 3000 | 69 | SN 8 |
| 110 | 3,2 | 4000 | 69 | SN 8 |
| 110 | 3,2 | 6000 | 69 | SN 8 |
| 160 | 4,0 | 500 | 87 | SN 4 |
| 160 | 4,0 | 1000 | 87 | SN 4 |
| 160 | 4,0 | 2000 | 87 | SN 4 |
| 160 | 4,0 | 3000 | 87 | SN 4 |
| 160 | 4,0 | 4000 | 87 | SN 4 |
| 160 | 4,0 | 6000 | 87 | SN 4 |
| 160 | 4,7 | 500 | 87 | SN 8 |
| 160 | 4,7 | 1000 | 87 | SN 8 |
| 160 | 4,7 | 2000 | 87 | SN 8 |
| 160 | 4,7 | 3000 | 87 | SN 8 |
| 160 | 4,7 | 4000 | 87 | SN 8 |
| 160 | 4,7 | 6000 | 87 | SN 8 |
| 200 | 4,9 | 500 | 107 | SN 4 |
| 200 | 4,9 | 1000 | 107 | SN 4 |
| 200 | 4,9 | 2000 | 107 | SN 4 |
| 200 | 4,9 | 3000 | 107 | SN 4 |
| 200 | 4,9 | 4000 | 107 | SN 4 |
| 200 | 4,9 | 6000 | 107 | SN 4 |
| 200 | 5,9 | 500 | 107 | SN 8 |
| 200 | 5,9 | 1000 | 107 | SN 8 |
| 200 | 5,9 | 2000 | 107 | SN 8 |
| 200 | 5,9 | 3000 | 107 | SN 8 |
| 200 | 5,9 | 4000 | 107 | SN 8 |
| 200 | 5,9 | 6000 | 107 | SN 8 |

6. PACKING, STORAGE, TRANSPORT

6.1 PACKING

The pipes are packed on palette.

Often the packaging method depends on individual arrangements with a recipient.

6.2 STORAGE

Pipes should be stored in a horizontal position, on an even surface, on wooden, or made of other material, pallets or platforms, spaced in distances from 0.7 to 2 m. Pipes during their storage, should be protected against mechanical impacts that would lead to damage or lower functional properties.

Because these plastics have limited resistance to elevated temperature and ultraviolet radiation, longer storage of products should take place in roofed or enclosed spaces, to protect them against direct and excessive sunlight.

6.3 TRANSPORT

Pipes should be transported in a horizontal position, means of transport of appropriate length. During loading, unloading and storing the pipes should be protected against mechanical damage. During the reloading work, steel ropes should not be used. Products should not be dropped and pulled on the ground but carried.

Special care should be taken at ambient temperatures low than +5 °C.

7. MARKING

The marking on the pipes includes:

- the company sign - the company logo - ARMAKAN PVC;
- manufacturer's address - Wądoły 20, 56-400 Oleśnica;
- manufacturing plant address - Moniuszki 21, 56-400 Oleśnica;
- trade name – Pipe for external sewage SN4 or SN8;
- type of material – PVC-U;
- dimensions - diameter X wall thickness e.g. 160x4,0;
- nominal peripheral stiffness – e.g SN4;
- technical specification number – PN-EN 13476-2:2018-05;
- application area symbol – „UD”;
- construction mark together with the last two digits of the year, in which it was placed on the construction product for the first time
- no. of the national declaration of performance - e.g. KDWU nr 3/2018;
- date and time of production - dd.mm.yyyy hh:mm;
- production line number - e.g. L:1.



8. SYSTEM INSTALLATION

When installing pipes and fittings, national and/or local requirements and technical regulations should be taken into account.

When assembling cup connections with an elastomer gasket, it is recommended to observe the following rules:

1. a bare end should be beveled;
2. bare ends of pipes should be cut at the construction site, they should be cut perpendicular and chamfered in the same way, like finished pipes and fittings supplied by F. P. H. U. "ARMAKAN" - PVC Kiebus Krzysztof;
3. bare ends, cups, and grooves for elastomer seals should be clean, and the gaskets should be properly placed;
4. only gaskets and lubricants supplied/recommended by the manufacturer of pipes and fittings should be used – F. P. H. U. "ARMAKAN" - PVC Kiebus Krzysztof;
5. The "SLIDER" sliding agent, which is used to facilitate the assembly and disassembly of plastic pipes and fittings, should be applied to the gasket and bare end of the pipe or fittings. This method significantly extends the service life of the gaskets. It is frost resistant and has the PZH attest (Państwowy Zakład Higieny - National Institute of Hygiene);
6. the bare ends should be axially aligned with the cups to be joined and inserted to the required depth.



9. GUARANTEE

The company provides sewage systems produced by it with the statutory warranty and guarantee for a period of 20 years from the date of sale under the following conditions:

1. proper transport, storage;
2. using the product for its intended purpose;
3. assembly of the sewage system, taking into account the specific requirements and relevant national regulations, guidelines for the implementation of the installation and technical regulations.

1. PRODUCT NAME

ARMAKAN PVC-U SN 2 pipes with structural wall for non- pressure sewage systems.

2. PURPOSE AND FEATURES OF THE PRODUCT

ARMAKAN pipes made of PVC-U SN 2 intended for sewage transport at a temperature of not higher than + 60°C for use in plumbing of non-pressure sanitary, rain and general drainage system.

Area of application: the symbol "U" (the symbol denoting the area of elements application in the underground water drainage and sewerage outside buildings) and outside the areas loaded with traffic.

3. TECHNICAL SPECIFICATIONS

National technical assessment ITB-KOT-2017/0149 edition 1 dated of 17.07.2017, valid until 17.07.2022.

4. DECLARED PERFORMANCE

| Essential characteristics of the product for the intended use or uses | Declared performance |
|---|---|
| Dimensions | according to table 1 and 2 |
| Temperature of softening temperature by Vicat [°C] | ≥ 79 |
| Impact resistance [%] | TIR ≤ 10 |
| Longitudinal shrinkage [%] | ≤ 5 no blisters, cracks and delamination |
| Peripheral stiffness [kN/m ²] | SN 2 ≥ 2 |
| Tightness of the socket connections | No leaks during testing and after the test, the decrease in vacuum ≤ 0.27 bar |
| Peripheral flexibility | No cracks or delamination at 30% of the deflection of the outer diameter |
| Abrasion resistance | Abrasion resistant pipe |
| Resistance to dichloromethane | The lack of impact |

Table 1. Dimensions of the pipes

| Nominal diameter DN | Average outside diameter and tolerance (+) [mm] | Wall thickness e [mm] | The thickness of the internal and external layer |
|---------------------|---|------------------------|--|
| 160 | 160.0 ^{+0.4/-0} | 3.2 ^{+0.6/-0} | 0.5 |
| 200 | 200.0 ^{+0.5/-0} | 3.9 ^{+0.6/-0} | 0.6 |

Table 2. Dimensions of the sockets

| Nominal size DN/DO | Nominal external diameter d _n [mm] | Socket | | | | | Bare end | |
|--------------------|---|---------------------------|--------------------------|--------------------------|-----------------------|-----------------------|--------------------------|--------|
| | | d _{sm, min} [mm] | e _{2, min} [mm] | e _{3, min} [mm] | A _{min} [mm] | C _{max} [mm] | L _{1, min} [mm] | H [mm] |
| 160 | 160 | 160.4 | 2.9 | 2.4 | 42 | 32 | 81 | 7 |
| 200 | 200 | 200.5 | 3.6 | 3.0 | 50 | 40 | 99 | 9 |

d_{sm, min} -the minimum average inside diameter of the socket

e_{2, min} -minimum thickness of the wall of the socket

e_{3, min} -minimum wall thickness in the groove zone

A_{min} -the minimum depth of the cup behind seal

C_{max} -the maximum depth of the sealing zone

L_{1, min} -the minimum length of the bare end

H – the length of the chamfer (approximate value)

5. ASSORTMENT

ARMAKAN PVC-U SN 2 PIPES WITH STRUCTURAL WALL FOR NON-PRESSURE SEWAGE SYSTEMS

PIPES



| Diameter DN/OD (mm) | Wall thickness e (mm) | L (mm) | L 1 (mm) | Peripheral stiffness (kN/m ²) |
|---------------------|-----------------------|--------|----------|---|
| 160 | 3,2 | 500 | 87 | SN 2 |
| 160 | 3,2 | 1000 | 87 | SN 2 |
| 160 | 3,2 | 2000 | 87 | SN 2 |
| 160 | 3,2 | 3000 | 87 | SN 2 |
| 160 | 3,2 | 4000 | 87 | SN 2 |
| 160 | 3,2 | 6000 | 87 | SN 2 |
| 200 | 3,9 | 500 | 107 | SN 2 |
| 200 | 3,9 | 1000 | 107 | SN 2 |
| 200 | 3,9 | 2000 | 107 | SN 2 |
| 200 | 3,9 | 3000 | 107 | SN 2 |
| 200 | 3,9 | 4000 | 107 | SN 2 |
| 200 | 3,9 | 6000 | 107 | SN 2 |

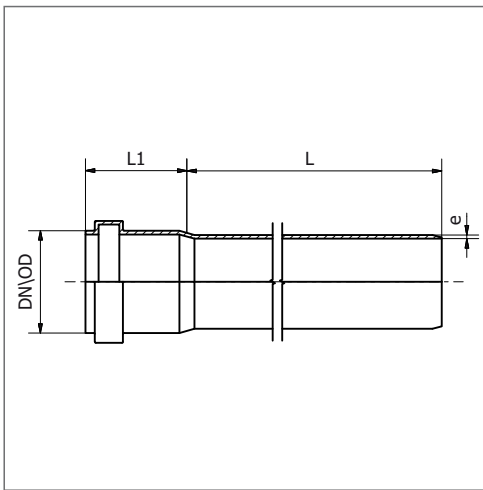

6. PACKING, STORAGE, TRANSPORT

6.1 PACKING

The pipes are packed on palette.

Often the packaging method depends on individual arrangements with a recipient.

6.2 STORAGE

Pipes should be stored in a horizontal position, on an even surface, on wooden, or made of other material, pallets or platforms, spaced in distances from 0.7 to 2 m. Pipes during their storage, should be protected against mechanical impacts that would lead to damage or lower functional properties.

Because these plastics have limited resistance to elevated temperature and ultraviolet radiation, longer storage of products should take place in roofed or enclosed spaces, to protect them against direct and excessive sunlight.

6.3 TRANSPORT

Pipes should be transported in a horizontal position, means of transport of appropriate length. During loading, unloading and storing the pipes should be protected against mechanical damage. During the reloading work, steel ropes should not be used. Products should not be dropped and pulled on the ground but carried.

Special care should be taken at ambient temperatures low than +5 °C.

7. MARKING

The marking on the pipes includes:

- the company sign - the company logo - ARMAKAN PVC;
- manufacturer's address - Wądoły 20, 56-400 Oleśnica;
- manufacturing plant address - Moniuszki 21, 56-400 Oleśnica;
- trade name – Pipe for external sewage SN2;
- type of material – PVC-U;
- dimensions - diameter X wall thickness e.g. 200X3,9;
- nominal peripheral stiffness – SN2;
- technical specification number – ITB-KOT-2017/0149 wydanie 1;
- application area symbol – „U”;
- construction mark together with the last two digits of the year, in which it was placed on the construction product for the first time
- no. of the national declaration of performance - e.g. KDWU nr 6/2017;
- date and time of production - dd.mm.yyyy hh:mm;
- production line number - e.g. L:1;



8. SYSTEM INSTALLATION

When installing pipes and fittings, national and/or local requirements and technical regulations should be taken into account.

When assembling cup connections with an elastomer gasket, it is recommended to observe the following rules:

1. a bare end should be beveled;
2. bare ends of pipes should be cut at the construction site, they should be cut perpendicular and chamfered in the same way, like finished pipes and fittings supplied by F. P. H. U. "ARMAKAN" - PVC Kiebus Krzysztof;
3. bare ends, cups, and grooves for elastomer seals should be clean, and the gaskets should be properly placed;
4. only gaskets and lubricants supplied/recommended by the manufacturer of pipes and fittings should be used – F. P. H. U. "ARMAKAN" - PVC Kiebus Krzysztof;
5. The "SLIDER" sliding agent, which is used to facilitate the assembly and disassembly of plastic pipes and fittings, should be applied to the gasket and bare end of the pipe or fittings. This method significantly extends the service life of the gaskets. It is frost resistant and has the PZH attest (Państwowy Zakład Higieny - National Institute of Hygiene);
6. the bare ends should be axially aligned with the cups to be joined and inserted to the required depth..



9. GUARANTEE

The company provides sewage systems produced by it with the statutory warranty and guarantee for a period of 20 years from the date of sale under the following conditions:

1. proper transport, storage;
2. using the product for its intended purpose;
3. assembly of the sewage system, taking into account the specific requirements and relevant national regulations, guidelines for the implementation of the installation and technical regulations.

1. PRODUCT NAME

Backwater gate TYPE -1 DN 110.

2. PURPOSE AND FEATURES OF THE PRODUCT

The backwater gate TYPE- 1 DN 110 made of PP is designed to protect buildings against internal splashing.

The backwater gate TYP 1 DN 110 is designed for installation in horizontal ducts, is equipped with an automatic closure mechanism and an emergency closure mechanism.

The automatic closure mechanism is a swinging gate (6), which automatically closes the duct in the event of a reverse flow. Under normal conditions, the suspended gate automatically regulates the free flow of sewage towards the channel.

The emergency closure mechanism is the same gate (6), which closes the duct by a manual lifting the lever (3) located on the cover (2) to its closed position.

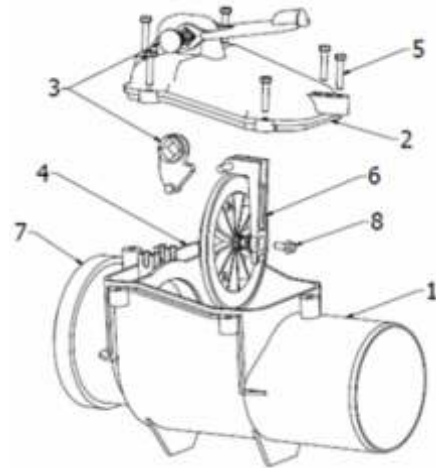

1. Body
2. Cover
3. Lever - manual closing
4. Cover gasket
5. Screws for the cover fastening
6. Closing gate
7. Connection cup with gasket
8. Screw fastening the closing gate

Fig. 1 Backwater gate TYPE - 1 DN 110

The use of material- PP (polypropylene), provides resistance to corrosion, high temperatures (up to +75 °C) and against chemical compounds.

3. TECHNICAL SPECIFICATIONS

PN-EN 13564-1:2004 Anti-flooding devices for buildings - Part 1: Requirements

4. DECLARED PERFORMANCE

| Essential characteristics | Performance | Harmonized technical specification |
|-----------------------------------|----------------------------|------------------------------------|
| Gas tightness (tightness for air) | Requirements are satisfied | PN-EN 13564-1:2004 |
| Watertight | Requirements are satisfied | |
| Effectiveness | Requirements are satisfied | |
| Resistance to temperature | Requirements are satisfied | |
| Mechanical strength | Requirements are satisfied | |
| Durability | Requirements are satisfied | |

5. PACKING, STORAGE, TRANSPORT

5.1 PACKING

The backwater gate TYP-1 DN 110 is packed in a cardboard box with the appropriate markings.

5.2 STORAGE

Backwater gate during their storage, should be protected against mechanical impacts that would lead to damage or lower functional properties.

Because these plastics have limited resistance to elevated temperature and ultraviolet radiation, longer storage of products should take place in roofed or enclosed spaces, to protect them against direct and excessive sunlight.

5.3 TRANSPORT

Avoid transporting backwater gate in bulk, together with other building materials, to avoid mechanical damage. Products should not be dropped and pulled on the ground but carried.

6. MARKING

The marking on the backwater gate includes:

- the company sign - the company logo - ARMAKAN PVC;
- device type - TYPE -1;
- type of material - PP;
- technical specification number – EN 13564;
- nominal size of the outflow - DN 110;
- flow direction;
- lever position marking;
- CE mark together with the last two digits of the year, in which it was placed on the construction product for the first time e.g.
- production date - month and year.



7. SYSTEM INSTALLATION

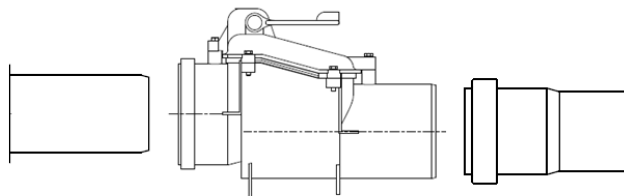

Fig. 2 Installation of the backwater gate TYPE - 1 DN 110 on a horizontal duct

Assembly

The backwater gate should be mounted directly on the horizontal duct, in accordance with the flow direction of non-fecal waste (rainwater, gray sewage), this direction is marked on the cover. Ensure that only sanitary items are connected to it, these items should be located below the level of flooding.

The backwater gate should be mounted in a way of ensuring free access for its inspection and maintenance during its operation.

The backwater gate requires a double sided connection to the pipelines, it is not an end gate.

Performing the test at the place of installation

In order to confirm the effectiveness of operation after the assembly of the gate valve, automatic and emergency closing mechanisms, a test simulating overloading should be carried out.

Test conditions:

Medium - water;

Pressure causing reverse flow - 1 kPa (0.01 bar);

The upper edge of the backwater gate inspection port should be the test pressure reference level.

Test time - 10 min.

The test result is considered positive if not more than 500 cm³ of the medium used in the test has been passed through the mechanism of automatic closure after reaching the pressure causing the reverse flow.

Service

Inspection at the place of installation of the backwater gate should be carried out twice a year by experienced personnel. In order to carry out the inspection, unscrew the screws which are fixing the cover (5), remove the cover (2), pull out the closing gate (6) and clean the backwater gate. Verify the condition of the gaskets and other elements of the backwater gate. In the event of a bad condition or damage to gaskets or other elements of the gate valve, they should be replaced. After cleaning the gate valve, the closing gate (6) must be installed, you should put the cover (2) on the body (1) and fix it using the fixing screws (5).

Finally, check the operation of the emergency closing mechanism by switching the manual closing lever (3) several times to the closed/open position. Finally, the manual closing lever (3) should remain in the open position.

8. GUARANTEE

The company provides sewage systems produced by it with the statutory warranty and guarantee for a period of 20 years from the date of sale under the following conditions:

1. proper transport, storage;
2. using the product for its intended purpose;
3. assembly of the sewage system, taking into account the specific requirements and relevant national regulations, guidelines for the implementation of the installation and technical regulations.

● BACKWATER GATE TYPE -1 DN 110

