

Hydrocore
water mist systems



EXPERTS IN WATER MIST SOLUTIONS

HIGH PRESSURE WATER MIST FIRE SUPPRESSION
for industrial and commercial use





EXPERTS IN HIGH PRESSURE WATER MIST

Hydrocore Limited was established in the UK in 2012, to design and manufacture, world class environmentally friendly, high pressure water mist fire suppression systems.

There are many approved and fire tested Hydrocore systems protecting people and property at industrial and commercial locations across the world.

These include Industrial Plants, Airports, Metro Stations, Rail Terminals, Road Tunnels, Transformer Substations, Engine Test Cells and many other risk- based applications.

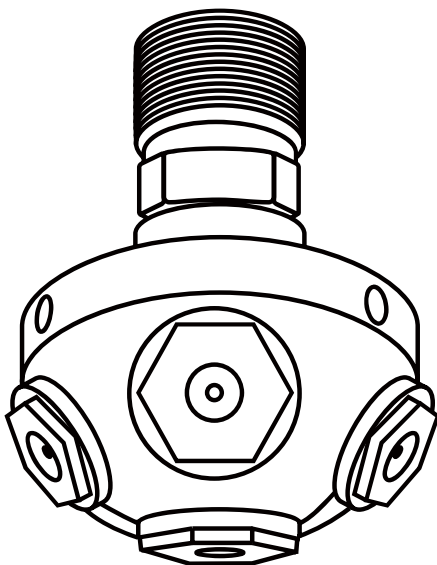

WHAT IS WATER MIST?

Water mist is a highly efficient fire suppression system which is defined by micro-droplets with the size $Dv0.99 < 1,000\mu m$. Having previously been used only at sea it has become apparent that water mist technology can have the same desired effect on land. Over the last decade, water mist has proven to be more effective than sprinklers for the majority of applications.

Micro droplets in Hydrocore's high-pressure water mist system quickly absorb the heat and instantaneously evaporate transforming from water to steam. The steam smothers the fire and prevents further oxygen from reaching it. At the same time, the evaporation creates a cooling effect.

The presence of the three elements: oxygen, heat energy and combustible material is essential for a fire to sustain and grow. The removal of just one of these elements helps suppress the fire.

Hydrocore's high pressure water mist system goes further and attacks two of the elements - oxygen and the heat energy - creating a highly effective fire suppression effect.

BENEFITS OF HIGH PRESSURE WATER MIST

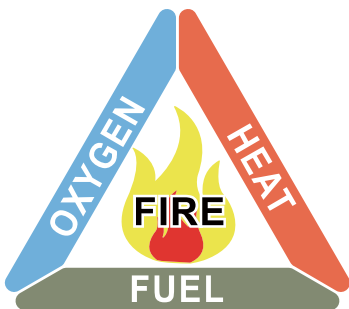
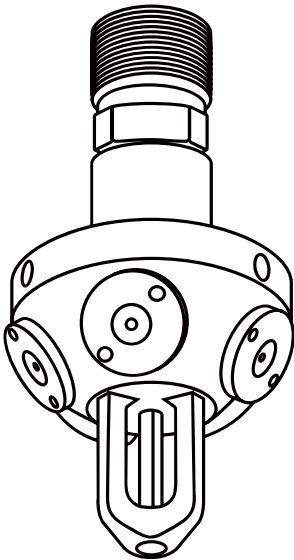

Quick & Effective Fire Suppression. Hydrocore High Pressure nozzles detect the fire and are automatically activated when the ambient temperatures rise beyond the set limit. Uniform cooling of the affected area suppresses the fire owing to the velocity and the angle of the water mist created by the nozzles. Also, the superior atomising effect offers reliable fire suppression and the cooling of the flammable material prevents re-ignition.

Low water usage. The efficiency of this process means it uses far less water than a traditional sprinkler system.

Minimal damage. Using small amount of pure water, Hydrocore high pressure water mist systems disperse finely atomised mist in the affected area. Atomised mist allows fast vaporisation limiting water damage.

Lower downtime and lower refill costs. Quick recovery and less downtime as against other suppression systems which need servicing or recharging after an activation. Only potable water is used which is readily available and at a low cost.

Ease of installation. Hydrocore high pressure water mist systems use a very small amount of water as compared to standard suppression systems and hence require smaller diameter pipes, which are easier to install and less intrusive.

Less space/weight. Water storage tanks for water mist systems are much smaller than those required for traditional sprinkler systems. This is where HPWM systems score highly as an existing building may not have enough space to accommodate a large water tank. Also, if the tank is to be installed anywhere but the basement, the floor may not be designed to carry as much weight.

Ease of maintenance. Use of water without any chemical additives and the use of stainless steel for high pressure piping makes the system corrosion resistant which enhances the equipment life and ensures low operation and maintenance costs.

Safe and environmentally friendly. Hydrocore high pressure water mist systems use only pure water as a suppression agent. Hence the system can be activated even when people are in the affected area and fire safety personnel can also enter the hazard zones when the system is in action. Also, unlike a gas suppression system, there is no risk of explosion in a water mist system.

ADVANCED TECHNOLOGY

HIGH PRESSURE WATER MIST

HYDROCORE High Pressure Water Mist Systems operate at more than 100bar pressure to atomise the water into a fine mist and to create enough velocity to drive out any fresh oxygen from reaching the seat of the fire. Operating at these pressures Hydrocore HPWM systems offer a volume coverage as against an area coverage offered by conventional sprinkler systems.

HIGH PRESSURE WATER MIST

SPRINKLER

COMPARED TO OTHER FORMS OF SUPPRESSION, **HIGH PRESSURE WATER MIST OFFERS MULTIPLE BENEFITS**

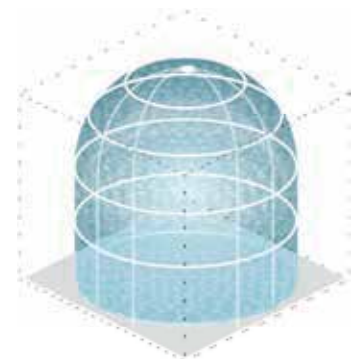

	Hydrocore High Pressure Water Mist	Low Pressure Water Mist	Sprinklers	Gas (FM200)
Suppression effect / Extinguishing Time	Quick	Moderate	Slow	Quick
Amount of water required	Less	Moderate	Large	NA
Water tank size	Small	Large	Very Large	NA
Water / Gas damage	Negligible	Substantial	Extensive	Negligible
Effect on electrical components	Negligible	Substantial	Extensive	Small
Evacuation before activation	Not required	Not required	Not required	Necessary
Pipe Sizes (Ease of Installation)	Small	Medium	Large	Small
Installation Cost	Moderate	Moderate	Low	Moderate
Power Required (kW)	High	Moderate	Low	Low
Lifetime Cost (Ownership Cost)	Medium	Medium	Low	High

In addition to the above, only potable water is required for Hydrocore's high pressure water mist systems, wetted parts are made from stainless steel and nozzles have integral filters, unlike a popular belief of HPWM requiring highly pure form of water. Also, stand-by system pressure is only 10-15bar and only during an activation the system pressure goes up to 100 bar, making the systems a safe installation even for protecting people. High pressure water mist can be used on electrical equipment and this can be demonstrated on any equipment having an IP rating of IP23 and above.

SYSTEM COMPONENTS



HYDROCORE PUMP UNITS

Compact and modular, our frame mounted pump units offer an output range of 100lpm to 700lpm at a minimum of 100bar pressure.

All pump units can be supplied with a stand-by pump and motor. Each pump unit is fitted with two jockey pumps (1 working + 1 stand-by) and a buffer tank. Pump units can be supplied with an optional star-delta configuration to reduce the electrical load on the system.

HIGH PRESSURE PUMPS

Oil free, water lubricated nine piston pumps have a reduced potential of cross contamination of water and lubricating oil. These pumps have a corrosion resistant stainless steel construction and are high efficiency low pulsation pumps which effects in substantial noise reduction during operation.

BOOSTER / FEEDER PUMP KITS

Booster pump units are supplied with a 10 micron filter set to feed filtered water into the high pressure pump unit. Each set is sized specific to the project.



SECTION VALVES

Section valves also called zone valves are either motorised (normally closed type for open nozzle systems) or manual (normally open type for closed nozzle systems). Section valves can be located near the hazard to be protected or near the pump station. They allow the flow of water to be directed to the zone of fire based on signals from the FPS and are also used to isolate zones during routine maintenance of the system. These come in various sizes and are chosen based on the water flow rate for the zone to be protected.

SYSTEM COMPONENTS

SYSTEM CONFIGURATION

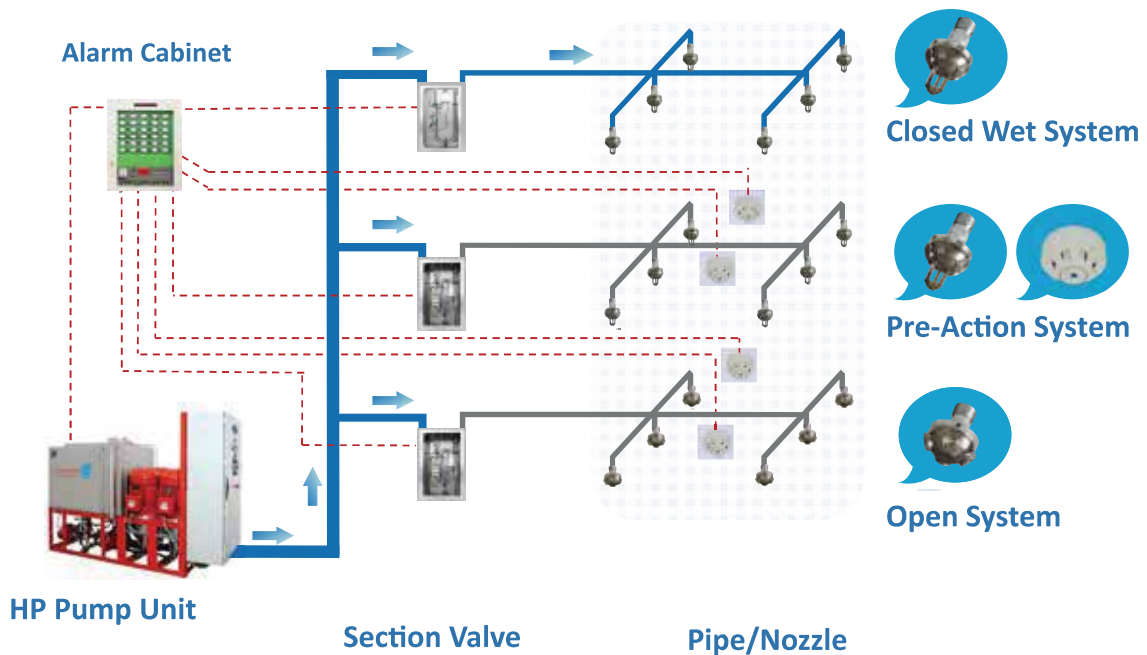

NOZZLES

Nozzles are one of the most critical components in a firefighting system and the ability of a firefighting system to extinguish / suppress a fire is dependent on the nozzle performance.

Hence, all Hydrocore nozzles undergo stringent fire and component tests and only approved nozzles are considered for use in our projects. Nozzles are typically of 2 types: Open nozzles and Closed (automatic) nozzles and are selected based on the hazard to be protected.

The nozzle body is manufactured from SS304 while the micro nozzles are made from SS316. Each micro nozzle is fitted with a filter to avoid any contaminants from blocking the openings.

For ordinary/light hazard and residential type occupancies, water mist systems are designed and tested to achieve property protection and life safety by controlling fires and reducing their damaging effects.

In case of industrial applications requiring machinery protection / volume or object protection water mist systems are designed and tested for extinguishment.



DATA SHEET

HIGH PRESUSRE PUMP UNIT

Model	Working Pressure bar	Flow Rate lpm
XSWB 100/14	140	100
XSWB 200/14	140	200
XSWB 300/14	140	300
XSWB 400/14	140	400
XSWB 500/14	140	500
XSWB 600/14	140	600
XSWB 700/14	140	700

NOZZLE

Model	K factor (lpm/bar ^{1/2})	Flow Rate (lpm)	Working Presusre (bar)
XSWT 1.25/10	1.25	12.5	100
XSWT 2.0/10	2	20	100
XSWT 3.5/10-57°C ϕ 2	3.5	35	100

SECTION VALVE SET

Deluge Section Valve	Working Pressure (bar)	Nominal Diameter
XSWFZ15/16	160	DN15
XSWFZ20/16	160	DN20
XSWFZ25/16	160	DN25
XSWFZ32/16	160	DN32
XSWFZ40/16	160	DN40
XSWFZ50/16	160	DN50

Wet Section Valve	Working Pressure (bar)	Nominal Diameter
XSWFZ20/16-B	160	DN20
XSWFZ25/16-B	160	DN25
XSWFZ32/16-B	160	DN32
XSWFZ40/16-B	160	DN40
XSWFZ50/16-B	160	DN50

Please contact us for more products

FIRE TESTED AND APPROVED SYSTEMS



FULL SCALE FIRE TESTING FACILITIES AND APPROVALS

Hydrocore are the **only British manufacturers** of industrial and commercial high pressure water mist systems and place great importance on offering fire tested solutions to their clients and on obtaining approvals from globally recognised bodies for their high pressure water mist systems.

Over the past years, **Hydrocore have gained FM Global approvals which comply with British Standards BS8489 for Protection of Combustion Turbines and Machinery in Enclosures (up to 260m³) and are one of the few companies globally to have gained FM Global approvals for Local Application Systems.**

Hydrocore have also successfully passed all the fire tests and component tests with FM global for Hazard Category 1 (formerly Light Hazard). Having access to extensive full scale fire test facilities, Hydrocore have conducted 3rd party witnessed road tunnel fire tests for fire loads up to 150MW.

NFPA 750 requires that fire testing is undertaken pertinent to the risk (9.2.4.1). Fire test protocols shall be designed to replicate the range of the application parameters associated with a particular hazard or occupancy. And in the absence of international standards or fire test protocols for certain applications, Hydrocore also offer to carry out performance based engineered fire tests. The performance based fire test protocol is agreed between stakeholders: Hydrocore and Tongtai Antai Disaster Engineering Prevention Engineering R&D Centre, the client, the consultant, the main contractor and the Authority Having Jurisdiction (AHJ).

Need a fire suppression system to protect your property or equipment? Call us on 01482 629 290 and we can carry out a detailed risk assessment. Based on the project requirements we can carry out fire testing at our own laboratory and offer you an engineered fire solution to suit your requirements.



HIGH PRESSURE WATER MIST APPLICATIONS



COMMERCIAL APPLICATIONS:

Protection of people and property are of vital importance and Hydrocore water mist systems are designed understanding the relevant European fire and safety standards.

Having undergone extensive fire testing, Hydrocore systems offer a very reliable and effective firefighting solution using minimal water. The closed nozzles have undergone rigorous testing at FM and can be used for protecting:

- **Apartments**
- **Atriums**
- **Churches**
- **Concealed Spaces**
- **Hospitals**
- **Hotel rooms**
- **Institutions**
- **Kitchens**
- **Restaurant Seating Areas**
- **Libraries**
- **Meeting rooms**
- **Metal working shops**
- **Mineral processing plants**
- **Museums**
- **Nursing Centres**
- **Office space**
- **Schools and Universities**

Hydrocore have passed the FM fire tests and component tests for HC-1 and can comply with BS8489 Part 7 for the protection of the above hazards.



Hydrocore high pressure water mist systems also help minimize the smoke content in the air which improves visibility and aids safe evacuation of people in case of a fire incident. Our eco-friendly systems use a very small amount of water and in the purest forms, without any additives. Nozzles are suitable to be fitted in new as well as old buildings as they complement the aesthetics of old, heritage buildings and at the same time their smart design makes them an easy fit in to modern constructions.

Today Hydrocore water mist systems are protecting iconic buildings like the Shanghai Tower, Shanghai Bank, a Rennie Mackintosh building in the centre of Glasgow to name a few.



INDUSTRIAL APPLICATIONS:

The industrial sector is characterized by considerable investment in heavy machinery which is expected to operate in an uninterrupted manner. Any downtime for capital intensive and critical equipment like turbines, transformers and machinery can lead to heavy losses and hence getting back to work quicker is very important after a water mist activation.

Hydrocore high pressure water mist systems are designed to fight fires, protecting people and property. Reliable and effective, our systems are designed to suppress the fire without any manual intervention. Hydrocore high pressure nozzles have been optimised to offer application specific flowrates, offering a fast response and quick fire suppression.



Hydrocore have FM approvals which comply with British Standards (BS 8489 Part 4 and Part 5):

- **Protection of Gas Turbines and Machinery in Enclosures (up to 260m³)** – Hazards like internal combustion engines, oil pumps, generators, transformer vaults, gear boxes, drive shafts, lubrication skids, generators, etc.
- **Protection of Local Application** – Hydrocore are one of the few companies globally to have these approvals! Water mist protection of local applications is considered a special protection system where the water is discharged directly or around the hazard to be protected.



PROJECTS



Shanghai Center Tower



Shanghai Bank Data Centre



China High Speed Railway



Qianfo Mountain Hospital, China

PROJECTS



FM Show Centre, Singapore



Radisson Edwardian Blu Hotel, London



Willow Tea Rooms, UK



Mayfair Luxury Property, UK

PROJECTS



China Metro



SPPG Cable Tunnel, Singapore



Hangzhou Metro Tunnel Water Mist Curtain



Tunnel Cooling

PROJECTS



PSA Port, Singapore



Shanghai General Motors



Changan R&D Centre, UK



BRUSH Electrical Machines, UK

PROJECTS



China State Grid

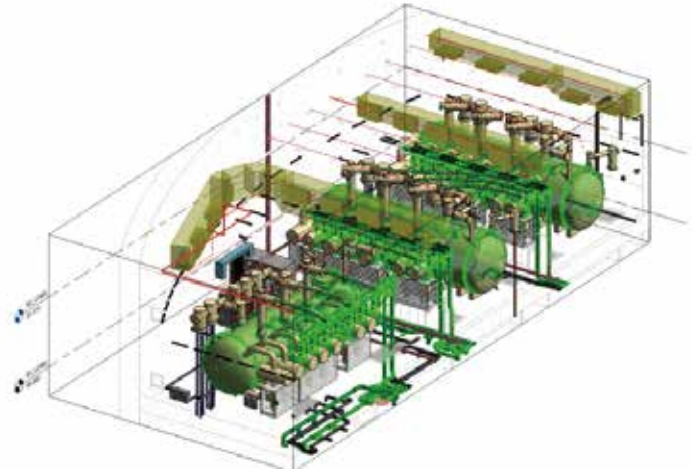

Underground 230kV GIT Substation, Singapore



230kV Substation, Southern Aluminum Smelter, Iran



China Offshore Substation

PROJECTS



The First Historical Archiver of China



China Tobacco



Egypt Misr Bank



The Second Historical Archives of China

PROJECTS



Shanghai Pudong International Airport



The MoD's Northern Ammunition Jetty in Glen Mallan, UK



PSA AA Generator Containers & Transformers, Singapore



Hammer Press Protection, UK

Hydrocore

water mist systems



+(44) 01482 629290
Email: info@hydrocore.co.uk

hydrocore.co.uk

Craven House, Harpings Business Park,
Harpings Road, Hull, HU5 4JF