



ANTI LOCK BRAKING SYSTEM ELECTRONIC BRAKING SYSTEM

Equipments for safe transportation



Introduction

ROYAL HI FIVE, specialized to support Tanker, Trailer, Tipping, Reefer manufacturing industry & Haulers by providing complete solution with component and system. ROYAL HI FIVE supply best quality components and systems with best performance with durability and reliability.

ROYAL HI FIVE cooperates with the best and well-known component manufacturing companies of the world to distribute their products locally and internationally.

ROYAL HI FIVE provides complete Anti-Lock Braking Systems for trailers with different configurations 4S/2M 4S/4M. ROYAL HI FIVE provides complete Electronic Braking Systems for trailers with different configurations 4S/2M, 4S/4M for Trailer with Air Suspension and Mechanical Suspension.

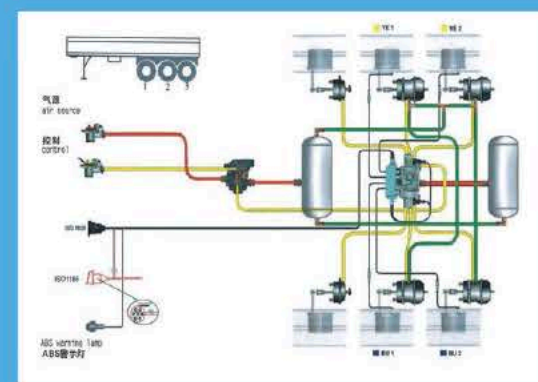

ROYAL HI FIVE provides one stop solution to the trailer builders industries. Complete range of parts including Trailer Axles 12 to 16 Tons, Bogie axles 24 to 32 Tons, Mechanical suspensions 36 to 48 Tons, Landing Gear 28 Tons, King Pin 2 & 3-1/2 inch, Twist Lock Wheel Rims and many more.



ROYAL HI FIVE provides complete Tipping Systems for Dumper Truck & trailers with different configurations. ROYAL HI FIVE provides Hydraulic Parts including Gear Pumps, Control Valve, PTO with different configurations



ROYAL HI FIVE provides complete range of hardware parts and accessories for Cargo Truck Body and Refrigerated Van and Trailers. Complete range of products for reefer truck including Locking Gears, Hinges different type, Door Retainers, Meat Hooks, chequered Aluminium Sheet



ROYAL HI FIVE provides one stop solution to the haulers in petroleum transportation industries. ROYAL HI FIVE product range includes the components for Tankers for Chemical and Fuel Grade products transportation.

ROYAL HI FIVE has complete solution for Top Loading, Bottom Loading, Vapor Recovery and Overfill Protection System for fuel Transporting Road Tank Trucks.



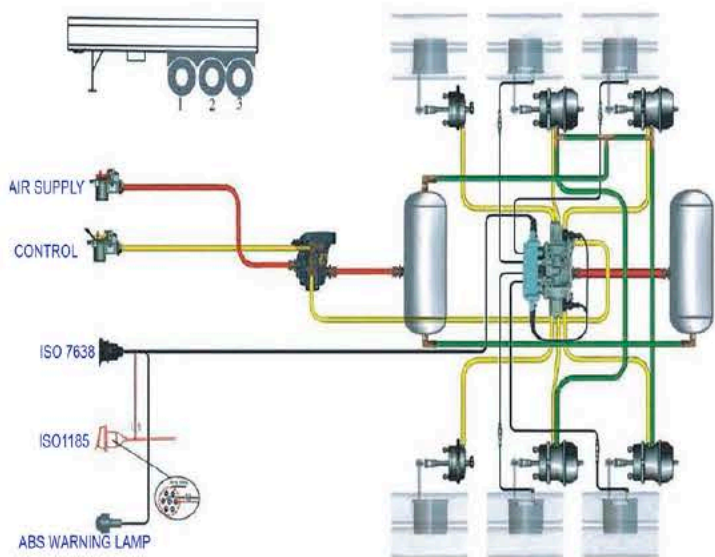

Anti Lock Braking System 4S/2M

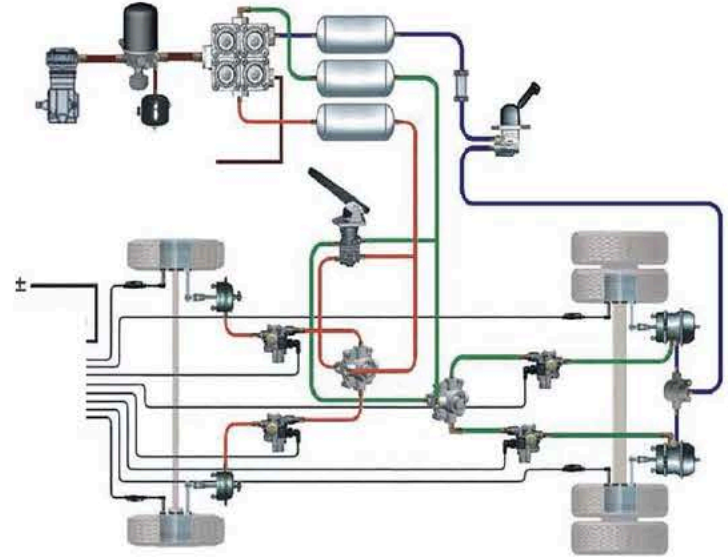

Anti Lock Braking System 4S/4M

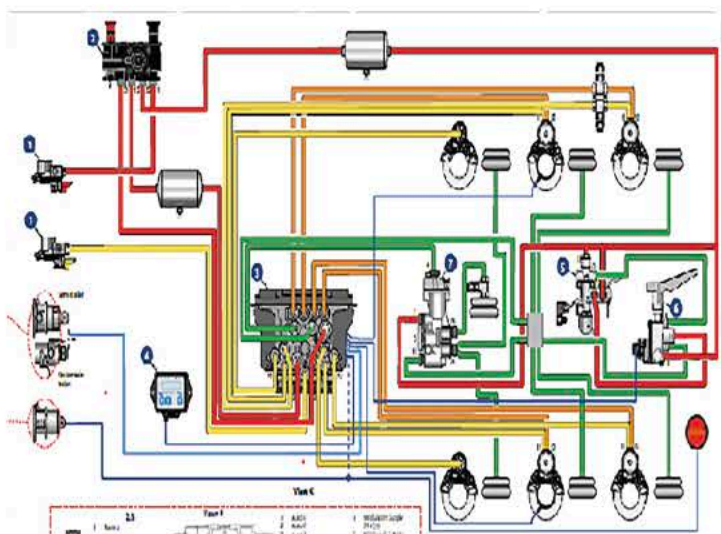

Electronic Braking System Pneumatic Suspension

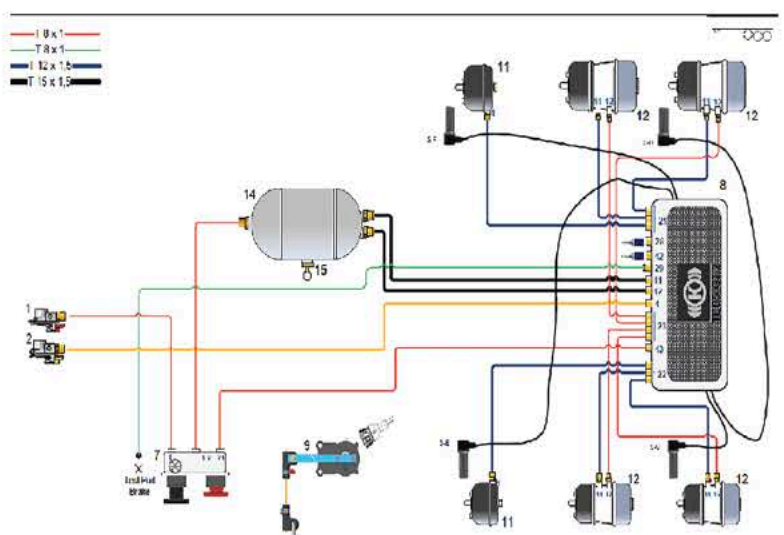

Electronic Braking System Mechanical Suspension

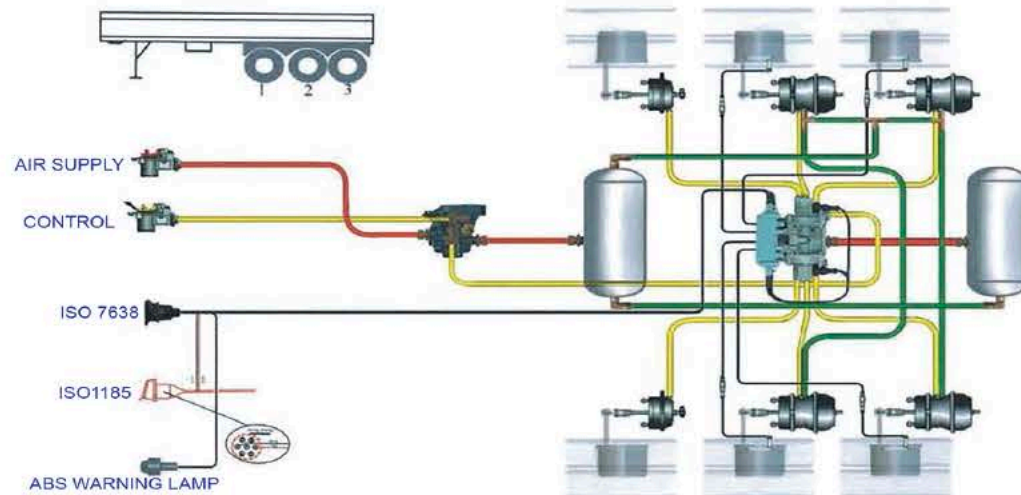

ANTI LOCK BRAKING SYSTEM 4S/2M FOR SEMI TRAILER



Anti Lock Braking System 4S/2m for Semi Trailer

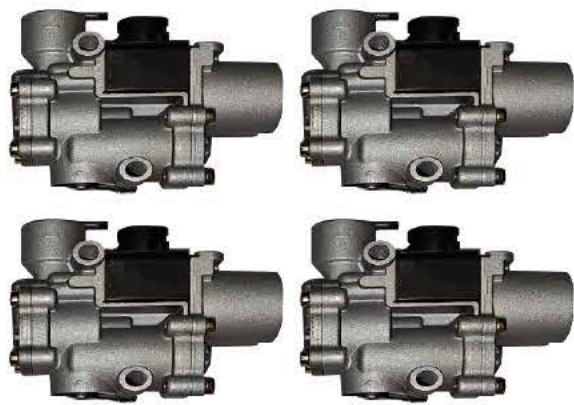
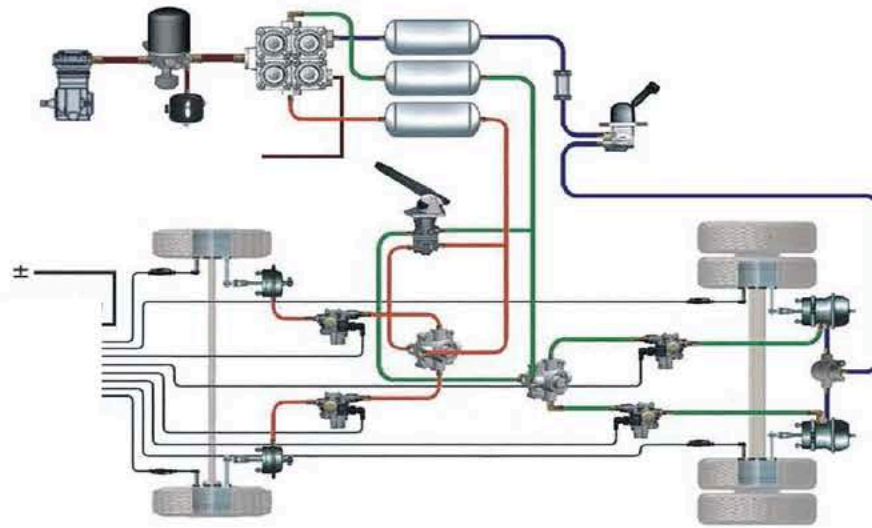

Modulator Solinoid Valve



ABS Modulator 4S/4M



Wiring Harness & Sensor Cable

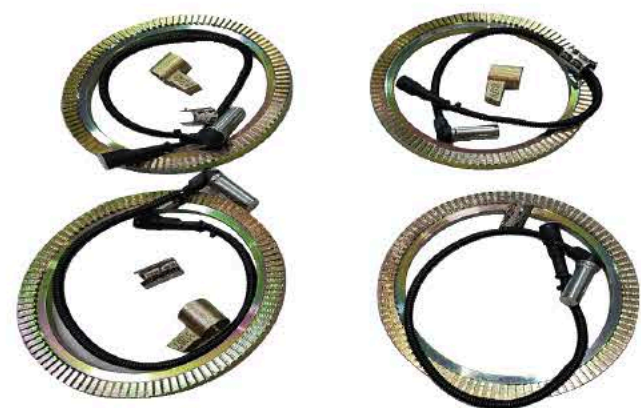

Sensor & Sensor Wheel

Anti Lock Braking System 4S/2m for Primer Mover

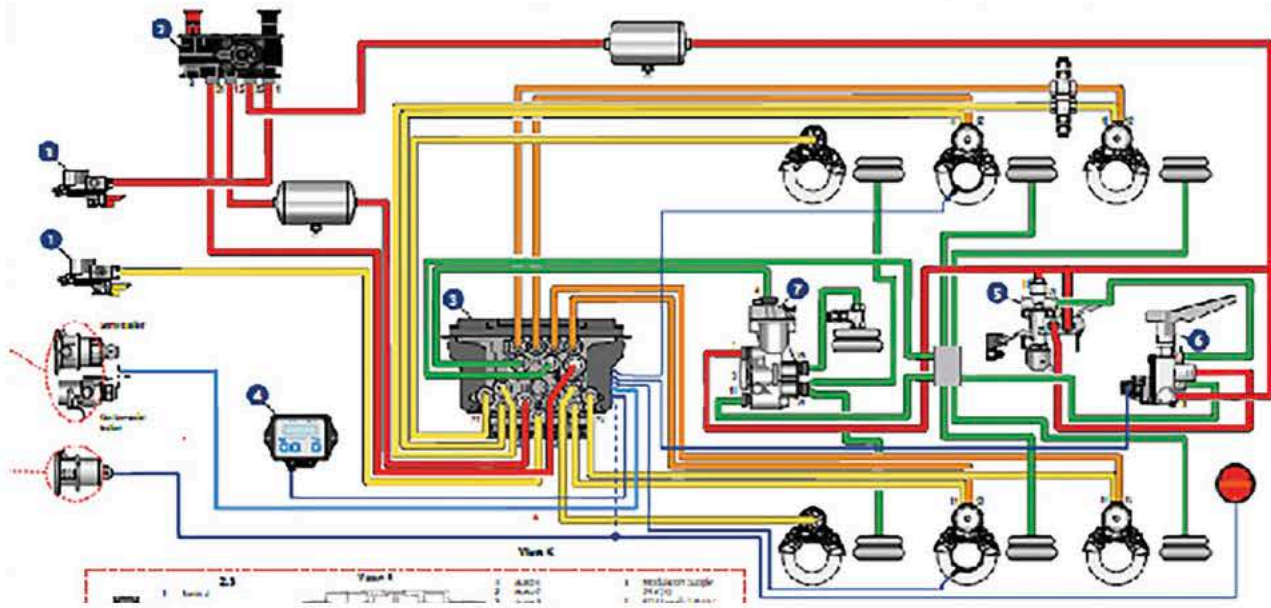

EBS Modulator Valve 4S/2M



Shunting Valve



Load Sensing Valve



Sensor

Electronic Braking System 4S/2m for Semi Trailer Electronic System

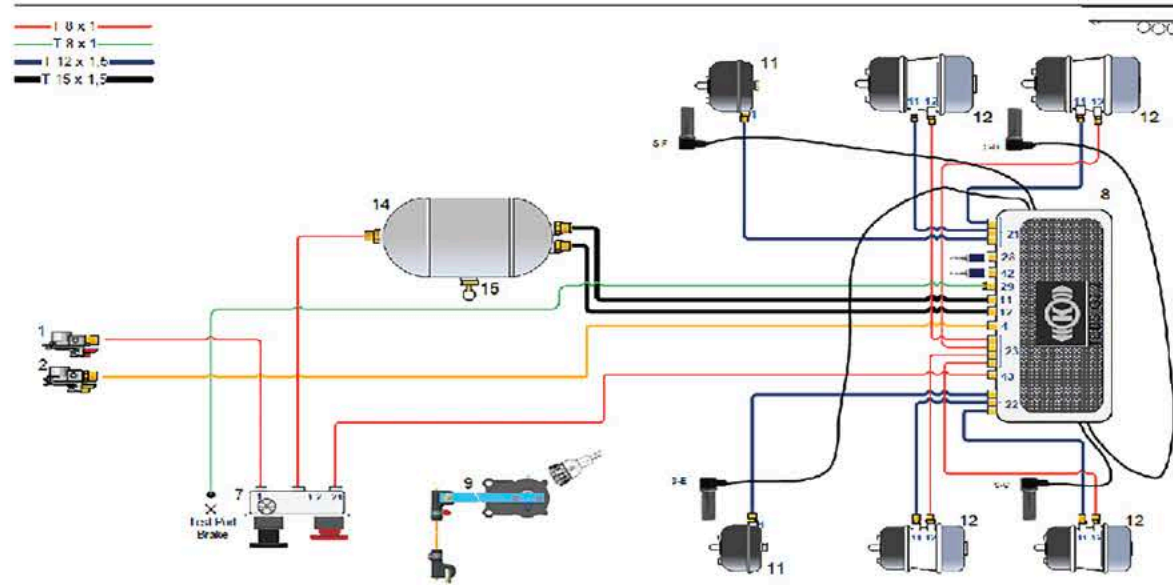

EBS Modulator Valve 4S/2M



Shunting Valve



Load Sensing Valve



Sensor

Electronic Braking System 4S/2m for Semi Trailer Mechanical System



Royal Hi Five

General Trading L.L.C

Warehouse : 14010 Al Sajja Industrial Area, Sharjah.

Office: 110, Shaikha Mahra Building, Al Qussais 2,
Al Nahda Road, Dubai, U.A.E.

Tell: +971 52 238 2185 Hassan Sheikh

+971 55 679 8756 Abdul Samad

+971 55 920 6786 Shan e Ahmed

Email: tanktruck@gmail.com

hassan.shaikh@royalhifive.com

abdul.samad@royalhifive.com

Web : www.royalhifive.com

Distributed / Represented By: