



Klauke

RIDGID

GREENLEE

Klauke

Receive the latest information about products, services and promotions.
Register for our newsletter:

[KLAUKE.COM/NEWSLETTER](https://www.klauke.com/newsletter)



Follow us!



© 2022 Gustav Klauke GmbH. All rights reserved. The Klauke logo and the Emerson logo are registered trademarks of Emerson Electric Co. or its subsidiaries in the USA and other countries. All other marks belong to their respective owners. Subject to change without notification. BRSOLAR22GB 2.000.06/22 |



TRUSTED SOLUTIONS FOR SOLAR PARK INSTALLATIONS

Klauke: The Go-to-Partner for Your Electrical Installation Work

Klauke

Gustav Klauke GmbH
Auf dem Knapp 46
D-42855 Remscheid, Germany

Phone: +49 (0) 2191 / 907 - 0
Klauke-Info@Emerson.com
Klauke.com



[Klauke.com](https://www.klauke.com)

TOP QUALITY – MADE BY KLAUKE

Always a secure connection...

... and that's our promise to you.

Since 1960, we've been the go-to partner for electrical connection materials. "Made by Klauke" means more than just a slogan: we do our own development, we are passionate about design, we manufacture the products ourselves and we have the highest expectations when it comes to the perfect connection. We perform testing regularly, both in our in-house laboratory and at independent test centers. This is how we ensure that all products we offer you are of outstanding quality, fully compatible and combined into a perfect system.

Our extensive portfolio is a proof of our expertise. We offer solutions in electrical connection technology from 0.14 to 1,000 mm², for almost every challenge in electrical installation. As a trendsetter, we've created our own cable lug series (the R-Series), and work closely with key customers when it comes to customized individual solutions for various applications.

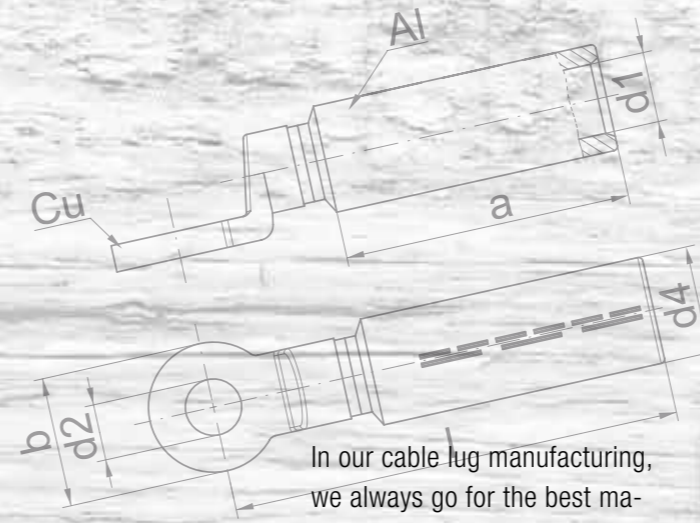

In our cable lug manufacturing, we always go for the best materials, using high-purity copper and aluminum, which ensure a perfect electrical connection. The soft copper ensures an optimized material flow during crimping and reduces the effort required.

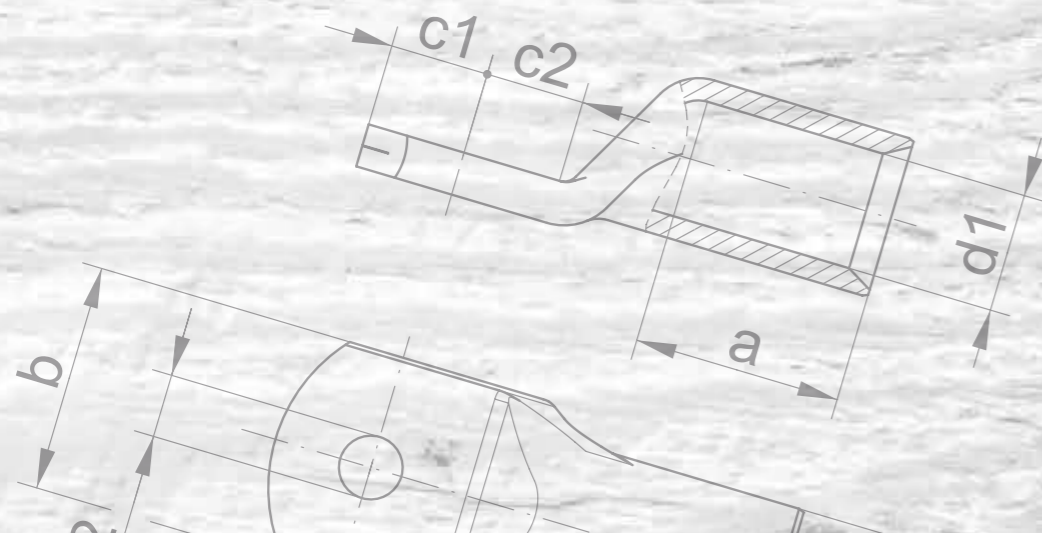

From development...



...to production...



...to finished end product...



...with the latest technology.

SINCE 1960



OUR PROMISE

Klauke takes your needs seriously. For us, "Made by Klauke" means that all products are manufactured with the highest quality.

ALWAYS ON THE SAFE SIDE, WITH KLAUKE

Safety and reliability through quality

Our products are tested by authorized inspection agencies certified to ISO 17025 so that we're able to offer our customers – and thereby your customers, too – the highest safety and reliability possible. This ensures accurate and reliable test results. The scope of testing ranges from the connection materials we use to the tools we make. This serves to firmly

establish the prerequisites for market entry and guarantees quality assurance, because the conformity assessment includes performance and qualification testing ranging from drop tests, flammability tests and functional safety tests to screw tear-out tests and much more.

CERTIFICATES

Company

- ISO 14001
- ISO 9001

Quality of the connection

- IEC 61238-1 (Class A)
- UL468A-468B
- DNV

Safety of the tools

- IEC 62841-1
- VDE nach REG. F647



Merely meeting the standards' requirements is not enough for us. When it comes to safety and reliability, usability and robustness, Klauke's products fulfill the highest demands and deliver more than the standards require.

Certified quality management systems of the Klauke companies

- ISO 9001:2015 - Customer- and process-oriented quality management system
- IATF 16949:2016 - The IATF 16949 standard goes beyond the DIN ISO 9001-series standards, and is the internationally recognized standard for quality management systems in the automotive industry.
- ISO 14001:2015 - Environmental management systems for continuously improving environmental performance



A COMPLETE SOLUTION FOR QUALITY SOLAR INSTALLATIONS

Solar power systems are an essential green energy source for the present and future generations. But if we talk about the optimal efficiency of the solar panels, a factor that is often underestimated is the quality and reliability of the electrical connection elements.

When it comes to safe and reliable cable connections, Klauke has proven expertise for over 60 years. From engineering and design, to customized solutions, manufacturing and services, Klauke is the industry leader in connecting materials and electrical tools.



In a solar park you will find Klauke products every time when you connect a combiner box, an inverter or a transformer.



Inverter

With the mostly prefabricated inverters, professional cable processing and connection is a must-have.



Compression cable lugs, Al/Cu EKM6022 ESM50



Combiner Box

When connecting a combiner box, it is important to establish a safe connection.



EKM601D Compression cable lugs, Al/Cu EK50ML Wire ferrules

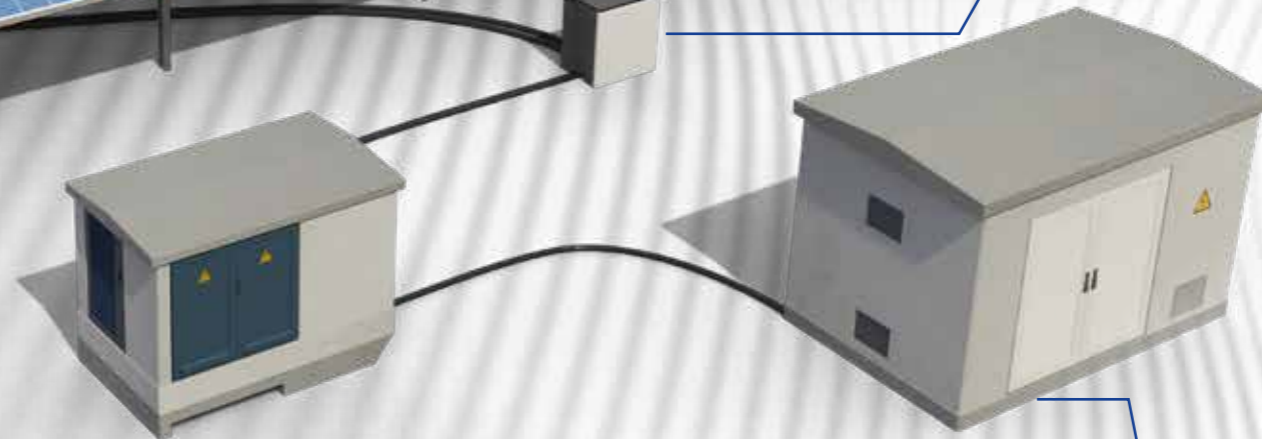

Tubular cable lugs, Cu EK301DML Wire ferrules EKWF120ML



Transformer

For transformers, various applications of electrical connection material come into play.

COMBINER BOX INSTALLATION



EKM 60 ID

Battery powered hydraulic crimping tool
10 - 240 mm²

- Extra large crimping area due to innovative 2-stage telescopic cylinder
- Indent crimping - no change of crimping dies required

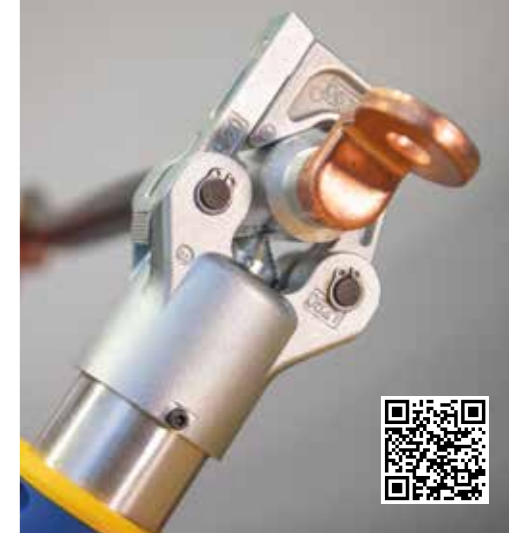

EK 50 ML

Electromechanical crimping tool
0,5 - 50 mm²

- With the multitude of available crimping dies, the Klauke micro offers a very wide range of applications
- Excellent crimping results with minimum effort



EKM 60/22

Battery powered hydraulic crimping tool
6 - 300 mm²

- The EKM6022 has a very large crimping range of up to 300 mm²
- Interchangeable crimping dies of the 22 series can be used

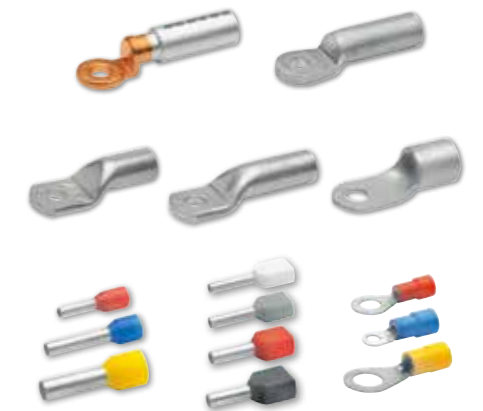

ESM 50

Battery powered hydraulic cutting tool
50 mm dia. for copper and aluminium cable

- High cutting power for cutting copper and aluminium cables (fine-stranded also)
- Saves time with multiple cuts thanks to the manual retract stop (MRS)
- Very low weight (3kg)
- Optimum center of gravity



ES 32 F ML / ES 32 ML

Battery powered hydraulic cutting tools
32 mm dia.



- The ES32FML is ideally suited for cutting fine and superfine stranded copper cables
- The ES32ML is designed for cutting multi-stranded copper and aluminium cables
- Both tools have a slim cutting head - ideal when space is critical

Compression cable lugs, Al/Cu and aluminum, tinned

Al/Cu: 16 - 400 mm², Aluminum: 16 - 500 mm²

- For non-tension connections of Al conductors to DIN EN 60228
- Tube dimension to DIN 46329



Tubular cable lugs, Cu, standard type

6 - 400 mm², R-Series

- For multi-stranded round conductors, e.g. to DIN EN 60228 Cl. 2
- In combination with the EKM 60 ID suitable for fine wired conductors
- For pre-rounded multi-stranded sector shaped conductors
- Also available as a connector



Insulated cable end-sleeve according to DIN with Easy-Entry

- For fine and superfine stranded conductors, e.g. according to DIN EN 60228 Cl. 5 and 6
- Easy-Entry Insulation for splice-free cable entry
- Alternative color codings available



K 507 WF

Crimping tool with interchangeable crimping dies for wire ferrules, 0,5 - 50 mm²

- Changing crimping dies on the K507WF is quick and easy (dies easily stowed in the handle)
- Due to the optimum width, fewer pressings are required





INVERTER INSTALLATION

EKM 60 ID

Battery powered hydraulic crimping tool
10 - 240 mm²

- Extra large crimping area due to innovative 2-stage telescopic cylinder
- Indent crimping - no change of crimping dies required



Compression cable lugs, Al/Cu

16 - 400 mm²

- For connecting aluminum conductors to copper terminals
- For non-tension connections of Al conductors to DIN EN 60228
- Tube dimension to DIN 46329



EKM 60/22

Battery powered hydraulic crimping tool, 6 - 300 mm²

- **Extremely fast:** Automatic retract stop (ARS) for positioning control in case of multiple crimps



ESM 50

Battery powered hydraulic cutting tool
50 mm dia. for copper and aluminium cable

- **High cutting power** for cutting copper and aluminium cables (fine-stranded also)
- **Saves time** with multiple cuts thanks to the manual retract stop (MRS)
- Very **low weight** (3kg)
- **Optimum center of gravity**





TRANSFORMER INSTALLATION

Speed test Automatic Retraction Stop (ARS)

with a 95 mm² compression cable lug Al/Cu with six crimps



**SAVE
39%
OF THE TIME**

With ARS → 22 Sec.

Without ARS → 36 Sec.

EKM 60/22

Battery powered hydraulic crimping tool, 6 - 300 mm²



- **Extremely fast:** Automatic retract stop (ARS) for positioning control in case of multiple crimps



ES 32 F ML / ES 32 ML

Battery powered hydraulic cutting tools 32 mm dia.



- The ES32FML is ideally suited for cutting fine and superfine stranded copper cables
- The ES32ML is designed for cutting multi-stranded copper and aluminium cables
- Both tools have a slim cutting head - ideal when space is critical

ESM 50

Battery powered hydraulic cutting tool 50 mm dia. for copper and aluminium cable



- **High cutting power** for cutting copper and aluminium cables (fine-stranded also)
- **Saves time** with multiple cuts thanks to the manual retract stop (MRS)

EKM 60 ID

Battery powered hydraulic crimping tool 10 - 240 mm²

- Extra large crimping area due to innovative 2-stage telescopic cylinder
- Indent crimping - no change of crimping dies required



EK WF 120 ML

Battery powered hydraulic crimping tool for wire ferrules 6 - 120 mm²

- Simple and safe crimping using innovative technology
- Square crimping for optimal compatibility with the common clamps
- The use of interchangeable crimping dies is completely unnecessary because the square mechanism adjusts flexibly to the respective cable end sleeve shape

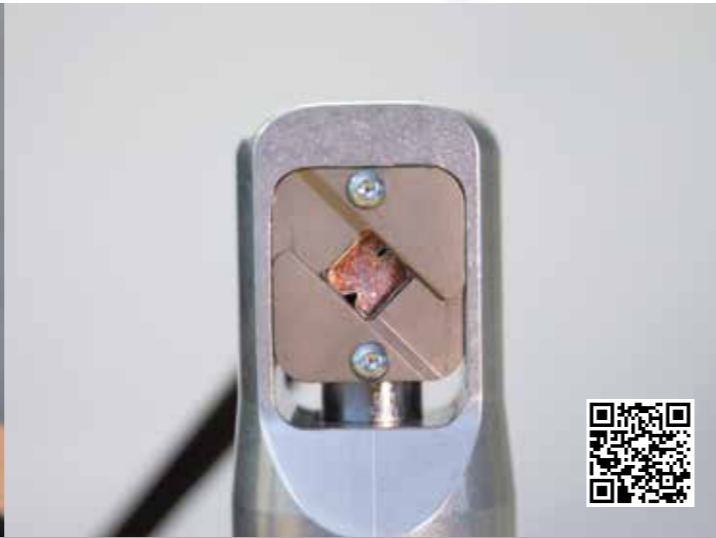
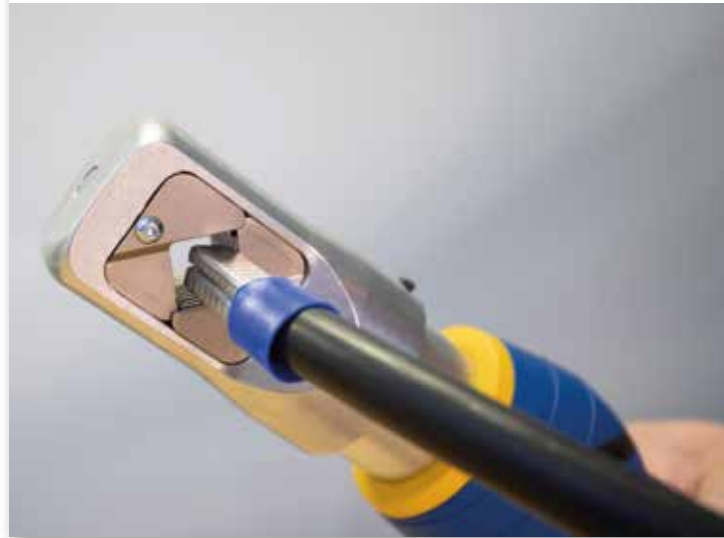

Compression cable lugs, Al/Cu

16 - 400 mm²

- For connecting aluminum conductors to copper terminals
- For non-tension connections of Al conductors to DIN EN 60228
- Tube dimension to DIN 46329



Tubular cable lugs, Cu, standard type

6 - 400 mm², R-Series

- For multi-stranded round conductors, e.g. to DIN EN 60228 Cl. 2
- In combination with the EKM 60 ID suitable for fine wired conductors
- For pre-rounded multi-stranded sector shaped conductors



Tubular cable lugs for switch cabinet (narrow palm) connections, Cu, standard type

35 - 300 mm²

- For multi-stranded round conductors, e.g. to DIN EN 60228 Class 2
- In combination with the EKM 60 ID suitable for fine wired conductors
- For fastening within switch cabinets with reduced connecting space



EK 30 ID ML

Battery powered hydraulic crimping tool 6 - 120 mm²



- Indent crimping - no change of crimping dies required



EK 50 ML

Electromechanical crimping tool 0,5 - 50 mm²



- The Klauke micro with intuitive PowerSense function combines the benefits of manual crimping tools with the convenience of battery powered hydraulic crimping tools



Insulated cable end-sleeve

according to DIN with Easy-Entry

- For fine and superfine stranded conductors, e.g. according to DIN EN 60228 Cl. 5 and 6
- Easy-Entry Insulation for splice-free cable entry
- Alternative color codings available



Insulated crimped cable lugs

0,1 - 6 mm²

- For fine and superfine stranded conductors, e.g. according to DIN EN 60228 Cl. 5 and 6
- Nach DIN 46237



K43/2V / K43/2U

Automatic wire stripper

K43/2V: 0,1 - 4 mm² / K43/2U: 4 - 16 mm²



- Self-setting cutting and stripping tool for application-specific solid and flexible cables
- No loss of individual strands - conductor inserts into the core sleeve more easily



K43/3

Wire stripper with stepless stripping range 0,03 - 16 mm²

- First wire stripper with stepless stripping range 0.03 - 16 mm²
- Ideal for damage-free stripping of solid and fine stranded conductors with PVC



LS 50 FLEX

Battery powered hydraulic punching tool

- Fast and clean work is guaranteed with the LS50FLEX
- Enjoy a high degree of flexibility with the rotating head



Speed Punch™

Rapid Hole punching system

- Innovative threadless punch profile
- Easy and quick handling as no screwing or unscrewing of the counter nut is required



ADDITIONAL TOOLS

STRUTSLAYR™

Strut Shear Head

- **Increased Efficiency** - Clean, consistent cuts in 5 seconds or less
- **Safe Operation** - No grinding or sawing sparks
- Compatible with RIDGID 32kN press tools





KLAUKE SYSTEM TRAINING

Always on the safe side with first-hand professional expertise

What cable lug works best for which cable? What form of crimping die works best in each application? What tool should you use? Does that apply for copper as well as aluminum? And what about DIN-compliant crimping?

The broad field of electrical connection technology is a complex subject area that requires expertise and precision. There is no room for error, as any mistake can be a threat to personal safety. Klauke offers training that clarifies what's right and what's wrong.

Hundreds of companies have already called on Klauke for training – from medium-sized businesses to large corporate groups: the content and scope of Klauke System training courses are always personally coordinated and agreed with you, customized to your applications and needs. Every participant completing a training program is of course awarded a personal certificate.

INFORMATION AND APPOINTMENT SCHEDULING

Training management

Peter Nowak
 Mobil phone: +49 (0)172 7051241
 Peter.Nowak@Emerson.com

THE KLAUKE MOBILE AND TECHNICAL CONSULTING

On-site tool demonstrations at your premises

The Klauke Mobile is a workshop on wheels packed full with the newest and most important tools: everything from compact hand-held crimping pliers to battery-powered hydraulic crimping machines handling up to 400 mm² – we have it all on hand, offering you every possibility to thoroughly try out and test the Klauke System.

We offer you the possibility to test our solutions first hand, on your job site and on the cables you use every day. Handy tools, powerful battery-driven hydraulic

shears like the exclusive VDE-tested Klauke ORANGE cutting tools or our safety cutters certified by the German institutions for statutory accident insurance and prevention –the Klauke Mobile has it all on board.

APPOINTMENTS

Simply speak to your personal technical consultant to arrange a visit, or contact us at:
 ■ Klauke-DACH@Emerson.com

Your partner for demanding work

Our Application Technology team also conducts tensile testing for your specific electrical connections, and advises you on selecting the right components, tools and processing methods – always applying state-of-the-art practices and complying with the applicable codes and standards.

No question is too hard or detailed: you can always reach us by e-mail or telephone for specific advice – that's how we clarify your specific application cases and questions in no time at all.

POINT OF CONTACT

■ Application Technology Hotline:
 +49 (0)2191 907-1070
 ■ Klauke-Anwendungstechnik@Emerson.com



ENVIRONMENTAL SUSTAINABILITY

Emerson is deploying environmental sustainability strategies and accelerating decarbonization across the globe.

Empowering a more environmentally responsible planet is ingrained in our company Purpose: We drive innovation that makes the world healthier, safer, smarter and more sustainable.

Emerson helps customers across some of the world's most essential industries make measurable sustainability progress, and we stand poised to help others along the same journey.

Our sustainable solutions are used in vital industries like power, life sciences, food and beverage, heating and cooling, energy, food service and more

Emerson utilizes a framework that groups our environmental sustainability efforts into three broad pillars: Greening Of Emerson, Greening By Emerson and Greening With Emerson.

Driving Net Zero Operations: Greening Of Emerson



How we are working to improve our internal environmental performance across our global business:

- Reducing Our Greenhouse Gas (GHG) Emissions
- Targeting Net Zero Operations by 2030
- Working Toward Net Zero Across Our Value Chain by 2045

Solving for Net Zero in Essential Industries: Greening By Emerson

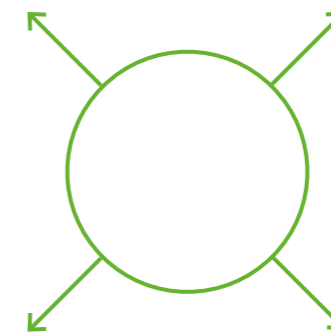

How we support and enable our customers' decarbonization and environmental sustainability efforts:

- Energy Source Decarbonization
- Electrification and System Integration
- Energy Efficiency and Optimization
- Emissions Management

Collaborating for a Net Zero World: Greening With Emerson

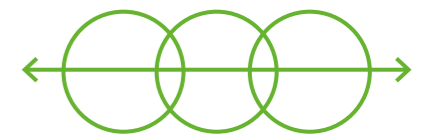

How we foster collaboration among stakeholders to discuss the way forward to a more sustainable future:

- Engaging our Governments and Policy Groups
- Collaborating with Leading Research Institutions
- Convening Leaders and Communities

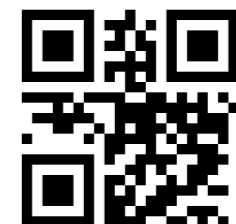

Scan to read ESG Report