

HYGIENE TECHNOLOGY IN PERFECTION



# PRODUCT CATALOGUE 2024

25  
YEARS +  
EXPERIENCE





**25 YEARS +**  
**HYGIENE TECHNOLOGY**  
**IN PERFECTION**



# TABLE OF CONTENTS

## 01 Hygiene Technology p. 7

Hand cleaning
Compact hand hygiene centre
Hand disinfection
Hand soaping
Dispenser and Accessories
Soles and boots cleaning / disinfection
Compact all-in-one hygiene stations
Hygiene stations and accessories
Turnstiles and portal turnstiles
Handrails and gates
Wheel cleaning

## 02 Cleaning Technology p. 87

Knife cleaning and disinfection
Knife baskets, apron hanger and accessories
Stab protective glove and apron cleaning
Boots and apron cleaning stations
Parts and small parts wash basins
Appliance dishwashers
Cover-type washing systems
Smoke stick and attachment rails washing systems
Box and pallet washing systems
Cabin and pass-through washing systems
▪ for lift trucks and feed trolleys
▪ for paloxes
▪ for smoke trolleys
Universal washing systems
Ecolab low pressure foam technology
▪ Stationary systems
▪ Master stations
▪ Satellite stations
▪ Mobile foam devices
▪ Guns, nozzles and lances
▪ Can holder
▪ Hoses
▪ Automatic hose rewinder
▪ Small parts and accessories

### **03** Social area equipment p. 185

---

- Wardrobe cabinets, single and two-storey

---

- Wardrobe cabinets, Z-shape

---

- Space-saving cabinets

---

- Small compartment cabinets

---

- Compartment cabinets closed

---

- Compartment cabinets open

---

- Laundry dispensing cabinets

---

- Laundry collector cabinets

---

- Benches and changeover benches

---

### **04** Factory Equipment p. 225

---

- Tables and desks

---

- Stools and standing aids

---

- Cabinets

---

- Drawer cabinets

---

- Wall-mounted cabinets

---

- Wall-mounted desks and standing desks

---

- Workshop trolleys

---

- Workshop facilities

---

- Storage, compartment cabinets and cleaning cabinets

---

- Computer cabinets

---

- Wall and spice racks

---

- Racks

---

- Pallet racks

---

### **05** Process/transport technology p. 315

---

- Smoke trolleys

---

- Sausage cart

---

- Defrosting trolleys

---

- Grid frames

---

- Smoking skewers

---

- Smoke stick trolley

---

### **06** Further product range p. 333

---

- Containers and transport equipment

---

- Pallet truck

---

- Swing loader

---

- Lift-tilting devices

---

- Drainage Technology

---

- Wall skirting protection

---

- Swing doors

---

### **List of products** p. 378

---

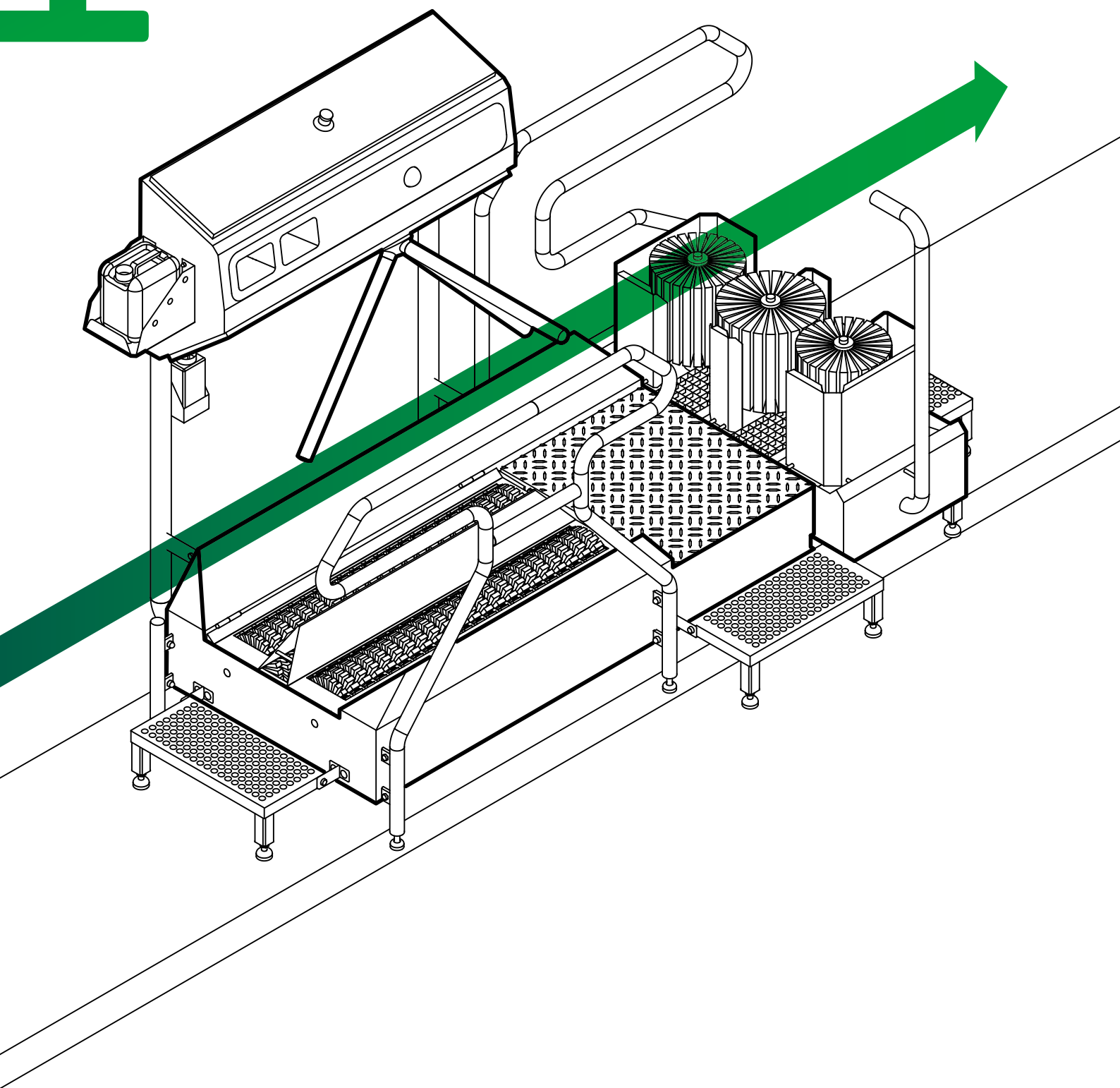

# 01

## Hygiene technology

Hand cleaning

---

Compact hand hygiene centre

---

Hand disinfection

---

Hand soaping

---

Dispenser and Accessories

---

Soles and boots cleaning / disinfection

---

Compact all-in-one hygiene stations

---

Hygiene stations and accessories

---

Turnstiles and portal turnstiles

---

Handrails and gates

---

Wheel cleaning

---

**TYPE HWB HIGHLINE**

# Hand wash basin



Type HWB-HL 1



Inner basin rounded (R: 20 mm)



Outlet tap with sensor

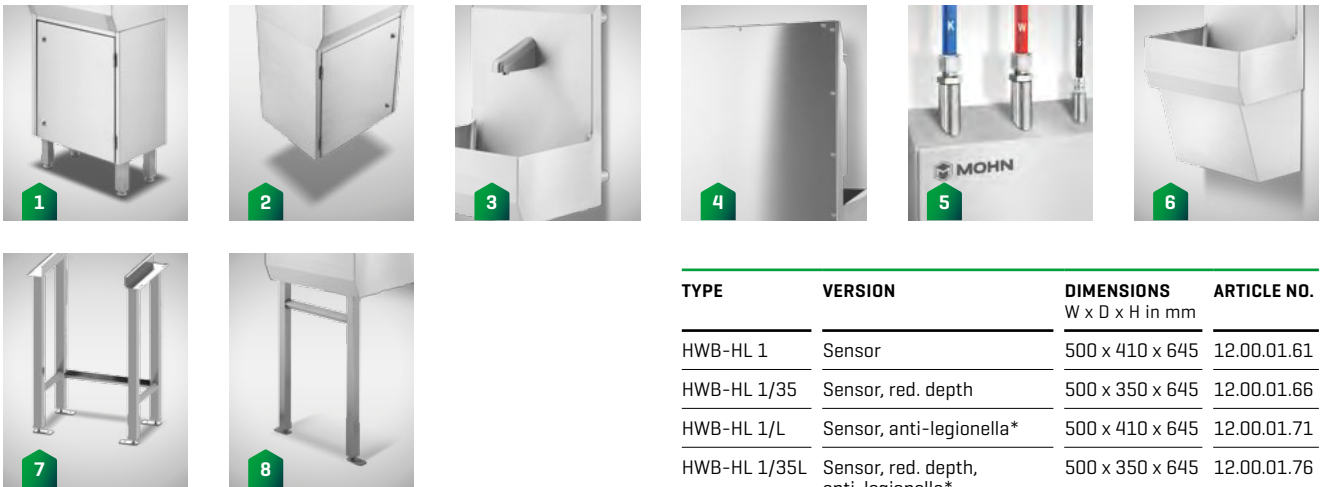

- Knee or sensor operation; also available with anti-legionella bacteria flushing by means of Siemens Logo control unit
- Stainless steel outlet tap including water-saving tap aerator
- Sensor integrated in water outlet tap, 24 V DC technology
- Thermostat mixing valve including non-return valve
- All parts are interchangeable without dismantling the hand basin from the wall!

**ADVANTAGES HYGIENE**

- No straight surfaces, functional MOHN-Hygienic-Design with pitched roof
- Inner basin rounded (R: 20 mm) No weld seams or joints in the basin, resulting in fewer contact surfaces for dirt, bacteria and germs.
- Optional wall spacer for optimum cleaning possibilities - also behind the MOHN Highline basin

**ADVANTAGES SIEMENS LOGO CONTROL UNIT**

- Individual programmability, customer-specific configuration of the rinse cycles is possible at any time.
- OPTIONAL: controllable via SMART CONTROL APP
- Operate your Siemens Logo control unit quickly and conveniently via your smartphone.

**ADVANTAGES TECHNOLOGY**

- Intelligent control and fast maintenance
- Sensor easily removable from the front for replacement, maintenance or for range adjustment [stepless at the touch of a button]
- The MOHN Highline basin does not need to be dismantled from the wall to change any spare parts.
- Optional anti-legionella bacteria flushing by means of Siemens Logo control unit, coupling with other units in the airlock possible, e.g. for a forced sequence with integrated outlet taps

TYPE	VERSION	DIMENSIONS W x D x H in mm	ARTICLE NO.
HWB-HL 1	Sensor	500 x 410 x 645	12.00.01.61
HWB-HL 1/35	Sensor, red. depth	500 x 350 x 645	12.00.01.66
HWB-HL 1/L	Sensor, anti-legionella*	500 x 410 x 645	12.00.01.71
HWB-HL 1/35L	Sensor, red. depth, anti-legionella*	500 x 350 x 645	12.00.01.76
HWB-HL 1/K	Knee operation	500 x 410 x 645	12.00.01.21
HWB-HL 1/35 K	Knee operation, red. depth	500 x 350 x 645	12.00.01.26

\*Sensor, anti-legionella bacteria flushing

**TECHNICAL DATA**

Water connection	3/4" AG; KW/WW; max. pressure: 2.5 – 6 bar
Mains supply	230 V; 50/60 Hz; 16 A (except knee operation)
Drain	1 1/2"

	HWB-HL 1 ARTICLE NO.	HWB-HL 1/35 ARTICLE NO.
1 Base cabinet floor model, DIN Left	12.00.01.82	12.00.01.83
Base cabinet floor model, DIN Right	12.00.01.31	12.00.01.32
2 Base cabinet wall-mounted, DIN Left	12.00.00.91	12.00.00.93
Base cabinet wall-mounted, DIN Right	12.00.00.92	12.00.00.94
3 Rear wall panelling with 100 mm spacer	12.00.01.14	12.00.01.14
4 Rear wall panelling [Stand-Alone]	12.00.00.36	12.00.00.36
5 Media supply from the top Water 2 x 1/2" IG	12.00.01.38	12.00.01.38
5 Media supply from the top Power	12.00.01.37	12.00.01.37
5 Media supply from the top Mixed water 1/2" IG	12.00.03.38	12.00.03.38
Flow water heater 3.5 kW	12.00.00.68	12.00.00.68
Skirting protection bar	12.00.04.06	12.00.04.11
6 Medium cover facing	12.00.01.41	12.00.01.46
7 Foot frame, stand foot FG-I	12.00.02.21	12.00.02.26
8 Foot frame, stand foot FG-II	12.00.02.31	12.00.02.36
Stagnation water monitoring STWÜ 1-4	93.00.00.99	93.00.00.99

**TYPE WR HIGHLINE**

**Wash trough**



Sensor wash trough Type WR-HL 4



Basin view: completely rounded



Wash trough Type WR-HL 2: Sensor operation with media facing

- Knee or sensor operation; also available with anti-legionella bacteria flushing by means of Siemens Logo control unit!
- Stainless steel outlet tap including water-saving tap aerator
- Sensor integrated in water outlet tap, 24 V DC technology
- Thermostat mixing valve including non-return valve
- Wall mounting rail
- All parts are interchangeable without dismounting the sluice from the wall!

**ADVANTAGES HYGIENE**

- No straight surfaces, functional MOHN-Hygienic-Design with pitched roof
- Inner basin rounded [R: 20 mm] No weld seams or joints in the basin, resulting in fewer contact surfaces for dirt, bacteria and germs.
- Optional wall spacer for optimum cleaning possibilities - also behind the MOHN Highline sluice





**ADVANTAGES SIEMENS LOGO CONTROL UNIT**

- Individual programmability, customer-specific configuration of the rinse cycles is possible at any time
- OPTIONAL: controllable via SMART CONTROL APP
- Operation of the Siemens Logo control unit via smartphone
- Water-saving option with the optional anti-legionella bacteria flushing: The control counts the water consumption per tap between the flushing intervals so that only as much water flows through as necessary during automatic rinsing.

**Example 4-station washing trough**

Outlet tap 1 is used more often than outlet tap 4, then outlet tap 4 is flushed correspondingly more often than outlet tap 1.

**ADVANTAGES TECHNOLOGY**

- Intelligent control and fast maintenance
- Sensor can be easily removed from the front for replacement, maintenance or for range adjustment, which is infinitely variable at the touch of a button
- The MOHN-Highline wash trough does not need to be removed from the wall to change all spare parts
- Optional anti-legionella bacteria flushing by means of Siemens Logo control unit, coupling with other units in the airlock possible, e.g. for a forced sequence with integrated outlet taps

**TECHNICAL DATA**

Mains supply	230 V; 50/60 Hz; 16 A [except knee operation]
Voltage	24 V/DC [except knee operation]
Drain	1 1/2" centred
Water connection	3/4"

**NUMBER OF WASHING PLACES (TOTAL WIDTH)**  
ARTICLE NO.

	<b>2</b>	<b>3</b>	<b>4</b>	<b>5</b>
<b>VERSION</b> D: 410 mm	W: 1,000 mm	W: 1,500 mm	W: 2,000 mm	W: 2,500 mm
Sensor operation	12.00.01.62	12.00.01.63	12.00.01.64	12.00.01.65
Sensor + Legionella	12.00.01.72	12.00.01.73	12.00.01.74	12.00.01.75
Knee	12.00.01.22	12.00.01.23	12.00.01.24	12.00.01.25
<b>VERSION</b> D: 350 mm	W: 1,000 mm	W: 1,500 mm	W: 2,000 mm	W: 2,500 mm
Sensor operation	12.00.01.67	12.00.01.68	12.00.01.69	12.00.01.70
Sensor + Legionella	12.00.01.77	12.00.01.78	12.00.01.79	12.00.01.80
Knee	12.00.01.27	12.00.01.28	12.00.01.29	12.00.01.30

**ADDITIONAL OPTIONS**

1 Media supply from the top "Power"	Article no. 12.00.01.37
1 Media supply from the top "Water 2 x 1/2" IG"	Article no. 12.00.01.39
1 Media supply from the top Mixed water „MW"	Article no. 12.00.03.39
Flow water heater [11 - 13.5 kW]	Article no. 12.00.00.78

**NUMBER OF WASHING PLACES**  
ARTICLE NO.

<b>OPTIONS</b>	<b>2</b>	<b>3</b>	<b>4</b>	<b>5</b>
2 Medium facing 410 mm	12.00.01.42	12.00.01.43	12.00.01.44	12.00.01.45
2 Medium facing 350 mm	12.00.01.47	12.00.01.48	12.00.01.49	12.00.01.50
3 Rear wall panelling with 100 mm spacer	12.00.01.15	12.00.01.16	12.00.01.18	12.00.01.19
4 Rear wall panelling with stand-alone	12.00.01.04	12.00.01.05	12.00.01.06	12.00.01.07
5 Foot frame FG-I	12.00.02.22	12.00.02.23	12.00.02.24	12.00.02.25
5 Foot frame FG-I/35	12.00.02.27	12.00.02.28	12.00.02.29	12.00.02.30
6 Foot frame FG-II	12.00.02.32	12.00.02.33	12.00.02.34	12.00.02.35
6 Foot frame FG-II/35	12.00.02.38	12.00.02.39	12.00.02.40	12.00.02.41



Cleancenter, Type HL-CC-II

**TYPE HL-CC**

# Cleancenter

STAINLESS STEEL 1.4301



Cleancenter Type CC-I (practical example)



LED signal indicators

For controlled cleaning or disinfection of the hands by means of forced sequence via integrated Siemens Logo control unit.

- Hygienic-Design version execution (no straight surfaces!)
- Inner basin complete with rounded corners [R: 20 mm]
- Stainless steel outlet tap including water-saving tap aerator
- Sensor integrated in water outlet tap, 24 V DC technology
- 2 contactless fittings for soap or disinfection application
- LED signal displays per non-contact fitting
- Base cabinet with hinged door for the storage of cans
- Siemens Logo control unit, freely programmable
- Thermostat mixing valve including non-return valve

TYPE	VERSION	DIMENSIONS W x D x H in mm	ARTICLE NO.
CC-I	2x soap	500 x 361 x 1402	12.00.01.35
CC-II	1x desi + 1x soap	500 x 361 x 1402	12.00.01.33

**TECHNICAL DATA**

Mains supply	230 V; 50/60 Hz; 16 A
Voltage	24 V/DC
Water connection	3/4"; KW/WW; 2.5 – 6 bar
Drain	1 1/2"

**OPTIONS**

Media "power" from above	Article no. 12.00.01.37
Media "water" from above, 1/2"	Article no. 12.00.01.38
Media "Mixed water" from above, 1/2"	Article no. 12.00.03.38
Flow water heater 3.5 kW	Article no. 12.00.00.68



Basin view: completely rounded



Outlet tap with sensor

01

**TYPE HWB-K, HWB-S**

## Hand wash basin

STAINLESS STEEL 1.4301



- Standard hand basin without back wall
- Wall-mounted by means of mounting rail
- Water outlet tap<sup>1</sup> + flow regulator chrome-plated
- Premixer for infinitely variable temperature control
- Adjustable sensor range [Type HWB-S]
- Anti-burst safety valve for knee operation [Type HWB-K]

TYPE*	VERSION	BASIN	DIMENSIONS	ARTICLE NO.
		W x D x H in mm	W x D x H in mm	
HWB-K 40	Knee operation	340 x 240 x 150	400 x 320 x 240	11.00.00.00
HWB-K 47	Knee operation	370 x 340 x 150	470 x 410 x 240	11.00.00.02
HWB-K 55	Knee operation	500 x 310 x 150	550 x 450 x 240	11.00.00.04
HWB-S 40	Sensor <sup>2</sup>	340 x 240 x 150	400 x 320 x 240	11.00.00.11
HWB-S 47	Sensor <sup>2</sup>	370 x 340 x 150	470 x 410 x 240	11.00.00.12
HWB-S 55	Sensor <sup>2</sup>	500 x 310 x 150	550 x 450 x 240	11.00.00.03

### TECHNICAL DATA

Mains supply	230 V; 50/60 Hz [Type HWB-S]
Drain	DN 40
Water connection	1/2" [cold + warm water]
Fuse protection	16 A [Type HWB-S]
Line pressure	min. 2.5 bar, max. 6 bar
Water outfeed height	200 mm

<sup>1</sup> HWB-K 40/47 + HWB-S 40/47: Water outlet tap on the side

HWB-K 55 + HWB-S 55: Water outlet tap centred

<sup>2</sup> Sensor operation

**TYPE HWB-SA 55**

## Hand wash basin

STAINLESS STEEL 1.4301



- Wall-mounted by means of mounting rail
- Sensor fitting included
- High-pressure fitting
- Stepless cold/warm adjustment
- Seamless deep-drawn basin

TYPE	VERSION	BASIN	DIMENSIONS	ARTICLE NO.
		W x D x H in mm	W x D x H in mm	
HWB-SA 55	Sensor <sup>1</sup>	500 x 310 x 150	550 x 450 x 240	11.00.00.45

### TECHNICAL DATA

Battery supply	DC 6 V [4 AA, included in the scope of delivery]
Drain	DN 40
Connection [HW/KW]	1/2"
Sensor range	100 - 150 mm
Fitting width	164 mm [Outreach of fittings: 120 mm]
Fitting height	182 mm
Outlet height	120 mm
Incl. connection hoses	G 3/8
Switch-on time	approx. 0.5 - 1 seconds

<sup>1</sup> Sensor operation

**TYPE HWB-SR-DT / WR-SR-DT 24V ECOLINE**

**Hand-washing basin, trough**

STAINLESS STEEL 1.4301



Hand wash basin HWB-SRW-DT 1



Hand wash trough WR-SRW-DT 2

- Rear wall with Dyson-Tab
- Hygienic-Design version
- Depending on version with 1 - 5 washing stations
- Washplace width: 500 mm
- 24 V/DC technology
- Dyson-Tap (AB 11) stainless steel sensor tap incl. Water-saving aerator and hand dryer
- Non-contact infrared activation
- Drying time: 12 seconds
- Wall-mounted using a mounting rail; available as a wall-mounted version or as a free-standing model
- Proportional mixing valve
- Base cabinet for Dyson-Tab

TYPE	VERSION	WASH-BASINS	DIMENSIONS W x D x H in mm	ARTICLE NO.
HWB-SRW-DT 1	Wall mount.	1	550 x 613 x 1161	12.00.02.81
WR-SRW-DT 2	Wall mount.	2	1050 x 613 x 1161	12.00.02.82
WR-SRW-DT 3	Wall mount.	3	1550 x 613 x 1161	12.00.02.83
WR-SRW-DT 4	Wall mount.	4	2050 x 613 x 1161	12.00.02.84
WR-SRW-DT 5	Wall mount.	5	2550 x 613 x 1161	12.00.02.85
HWB-SRS-DT 1	Floor model	1	550 x 613 x 1426	12.00.03.81
WR-SRS-DT 2	Floor model	2	1050 x 613 x 1426	12.00.03.82
WR-SRS-DT 3	Floor model	3	1550 x 613 x 1426	12.00.03.83
WR-SRS-DT 4	Floor model	4	2050 x 613 x 1426	12.00.03.84
WR-SRS-DT 5	Floor model	5	2550 x 613 x 1426	12.00.03.85

**TECHNICAL DATA TYPE HWB-SRW-DT 1**

Mains supply	230 V; 50/60 Hz
Operating voltage	24 V/DC
Power	1,600 Watt [Dyson-Tap]
Drain	DN 50 - centred
Water connection	1/2" [cold + warm water]
Line pressure	min. 2.5 bar, max. 6 bar
Operating temperature	0 °C - 40 °C
Air outlet speed	690 km/h

**TECHNICAL DATA TYPE WR-SRW-DT 2-5**

Mains supply	3x 400 V; N/PE; 50/60 Hz
Operating voltage	24 V/DC
Power	3,200 - 8,000 Watt [Dyson-Tap]
Drain	DN 50 - centred
Water connection	3/4" [cold + warm water]
Line pressure	min. 2.5 bar, max. 6 bar
Operating temperature	0 °C - 40 °C
Air outlet speed	690 km/h [per fitting]

01

**TYPE HWA-F**

## Hand wash basin and sink

STAINLESS STEEL 1.4301



Version with optional sensor fitting

- Stable, hygienic industrial design
- Hand-washing basin and sink on top of each other
- Foot frame with 355 mm ground clearance
- Both basins deep-drawn and seamlessly welded into the cover
- 3-sided stainless steel bowl cover
- Complete with 1-hole mixer tap, Ø 31 mm
- Sensor mixer fitting at an extra charge [optional]
- Installation integrated in the body
- Insert grid in the sink

TYPE	VERSION	DIMENSIONS W x D x H in mm	ARTICLE NO.
HWA-F 500	with foot frame	500 x 700 x 850	11.00.20.05

**OPTION**

Sensor mixer fitting	Article no. 97.13.88.90
----------------------	-------------------------

**TYPE MHS-ECO**

## Mobile hygiene station

STAINLESS STEEL 1.4301



- Ecoline series: Completely self-sufficient
- Stainless steel body, open at the back
- Mobile on 4 swivel casters
- Washbasin with drain and water supply
- Knee contact switch, front
- Fresh water tank with 25 litre capacity
- Soap dispenser and towel roll with attachment

TYPE	BASIN SIZE W x D x H in mm	DIMENSIONS W x D x H in mm	ARTICLE NO.
MHS-Eco	340 x 300 x 100	354 x 325 x 800	90.00.00.40

**TECHNICAL DATA**

Mains supply	230 V, 50 Hz [with optional heating]
Fresh water tank capacity	25 ltr.
Waste water tank capacity	25 ltr.
Weight	approx. 11 kg



**TYPE MHS-1**

## Mobile hygiene station

STAINLESS STEEL 1.4301



- Highline series: Partially self-sufficient supply!
- Robust housing made entirely of stainless steel
- Mobile on 2 rigid casters with handle
- 1 wash hand basin with single-lever mixer tap
- Paper towel and soap dispenser integrated in the lid
- Lid can be opened using 2 pressure cylinders
- MHS-1c: Fitting + soap dispenser: Sensor operation

TYPE	VERSION	BUILT-IN BASIN	DIMENSIONS <sup>1</sup>	ARTICLE NO.
		W x D x H in mm	W x D x H in mm	
MHS-1	Self-sufficient	400 x 325 x 120	640 x 400 x 1200	90.00.00.16
MHS-1a	Fixed <sup>2</sup>	400 x 325 x 120	640 x 400 x 1200	90.00.01.16
MHS-1c	Self-sufficient	400 x 325 x 120	640 x 400 x 1200	90.00.03.16

<sup>1</sup>Dimensions with closed lid; <sup>2</sup>Fixed connection

**TECHNICAL DATA**

Mains supply	230 V; 50 Hz [2 m connection cable included]
Drain	1/2" [GEKA coupling] with fixed connection
Water connection	1/2" [GEKA coupling] with fixed connection
Filler neck, right side	Manual fresh water filling [MHS-1 only]
Fresh water tank capacity	19 ltr. [Type MHS-1]
Waste water tank capacity	22 ltr. [Type MHS-1]

**TYPE MHS-2**

## Mobile hygiene station

STAINLESS STEEL 1.4301



- 2 hand basins - fixed connection
- Highline series: robust, hygienic and functional
- Robust housing made entirely of stainless steel
- Mobile version on 4 rigid casters
- Hand-rinse basin on the right with low-pressure mixer tap
- Left-hand sink with low-pressure mixer tap
- Paper towel and soap dispenser in the hand wash basin area
- Paper basket in the locker room

TYPE	VERSION	2 BUILT-IN BASINS		ARTICLE NO.
		W x D x H in mm	W x D x H in mm	
MHS-2	Fixed*	340 x 370 x 120	1000 x 600 x 1200	90.00.02.16

\*Fixed connection

**TECHNICAL DATA**

Mains supply	3x 400 V [2 m connection cable incl.]
Power	4 kW
Drain	1/2" [GEKA coupling] - fixed connection
Water connection	1/2" [GEKA coupling] - fixed connection

**TYPE USP-0**

## Universal dispenser, manual



- For soap or disinfectant
- Hygienic-Design
- Refillable reservoir [1,000 ml]
- Long, stable lever for hygienic elbow operation
- Sticker „Disinfection“ + „Soap“\*

TYPE	VERSION	DIMENSIONS W x D x H in mm	ARTICLE NO.
USP-0	Manual - open	98 x 90 x 325	18.00.00.15

**TYPE USP-A**

## Universal dispenser, manual



- For soap or disinfectant
- Hygienic-Design
- Refillable reservoir [1,000 ml]
- Long, stable lever for hygienic elbow operation
- Sticker „Disinfection“ + „Soap“\*
- Optional: Stainless steel sash drivers  
Article no. 99.80.03.69

TYPE	VERSION	DIMENSIONS W x D x H in mm	ARTICLE NO.
USP-A	Manual - lockable	98 x 90 x 325	18.00.00.35

**TYPE USP-L**

## Universal dispenser, manual



- Manual arm lever operation
- Lockable, incl. 2 keys
- With viewing window and scaling
- Refillable container [1,000 ml]
- Sticker „Disinfection“ + „Soap“\*

TYPE	VERSION	DIMENSIONS W x D x H in mm	ARTICLE NO.
USP-L	lockable, with scale	98 x 90/ 246 x 325	18.00.01.68

**TYPE USP-E-VA**

## Universal dispenser, automatic



- For soap or disinfectant
- Refillable reservoir [800 ml]
- Contactless sensor operation
- Battery operation [6x AA]
- Level glass gauge
- lockable
- Etching “soap” or “disinfectant”  
Article no. 90.00.00.95 [optional]

TYPE	VERSION	DIMENSIONS W x D x H in mm	ARTICLE NO.
USP-E-VA	Sensor operation	110 x 106 x 275	18.00.00.68

**TYPE HTSP**

## Towel dispenser, manual



- Capacity: 400 folded paper towels
- Hygienic-Design
- Pitched roof
- Level glass gauge made of break-proof polycarbonate
- Lockable [HTSP-A]

TYPE	VERSION	DIMENSIONS W x D x H in mm	ARTICLE NO.
HTSP-0	not lockable	275 x 135 x 355	18.00.00.01
HTSP-A	Lockable	275 x 135 x 355	18.00.00.45

**TYPE HTSP-E-VA**

## Towel dispenser, automatic



- Automatic paper toweldispenser [battery supply, 4 x 1.5 V]
- Contactless sensor operation
- Paper rolls with external take-off
- Paper rolls: W: 200 mm; Ø 190 mm
- Roller core: min. 38 mm
- Single-sheet dispensing
- Lockable housing

TYPE	VERSION	DIMENSIONS W x D x H in mm	ARTICLE NO.
HTSP-E-VA	Sensor operation	278 x 211 x 406	18.00.01.77



**TYPE RB-E**  
**Roll box**



- Hygienic-Design
- Pitched roof
- Paper rolls with internal take-off
- Paper rolls up to maximum  
Ø 260 mm
- Lockable (RB-E-A)

TYPE	VERSION	DIMENSIONS W x D x H in mm	ARTICLE NO.
RB-E-0	not lockable	280 x 250 x 400	19.00.00.12
RB-E-A	Lockable	280 x 250 x 400	19.00.00.17

**TYPE DR**  
**Dryrack**



- Robust frame for individual equipment with MOHN towel dispenser, roll box and waste paper basket

TYPE	VERSION	DIMENSIONS W x D x H in mm	ARTICLE NO.
DR-I	wall-mounted	245 x 75 x 1210	18.00.09.02
DR-II/-left	WR-mounting	245* x 41 x 1,051	18.00.09.03
DR-II/-right	WR-mounting	245* x 41 x 1,051	18.00.09.04

\* plus 25 mm for the distance to the wash trough



Type DR-II with wash trough

**TYPE JET II**  
**Hand drier**



- 2-hand High-performance hand dryer
- Hygienic-Design
- Drying time approx. 10 seconds
- Contactless sensor operation
- Splash water-proof version
- Wall-mounted version
- DN 40 drain connection; e.g. for connection to the siphon of the wash trough

TYPE	VERSION	DIMENSIONS W x D x H in mm	ARTICLE NO.
Jet II	2-hand, electrical	400 x 205 x 650	90.00.00.76

**TECHNICAL DATA**

Mains supply	230 V; 50 Hz; 16 A
Power	3.2 kW
Drain	DN 40

**\*OPTION: LABELLING SERVICE - ETCHING**

Labelling "Soap", "Desi" or as desired Article no. 90.00.00.95



**MORE INFO**

**TYPE MAS**

## Work coat dispenser



- With pitched roof in lid design
- For wall mounting
- Robust design with viewing window
- Capacity approx. 20 disposable coats
- Easy removal through dispensing opening

TYPE	CAPACITY	DIMENSIONS W x D x H in mm	ARTICLE NO.
MAS	20 coats	130 x 180 x 450/550	18.00.00.00

**TYPE EOS**

## Disposable ear plug dispenser



- Hygienic-Design
- Filling through lid with pitched roof
- Lid with overhang, advantage:  
No risk of finger pinching
- With large interior for big stocks of ear plugs
- Large withdrawal opening

TYPE	VERSION	DIMENSIONS W x D x H in mm	ARTICLE NO.
EOS	Wall-mounted	200 x 170 x 450/550	18.00.01.52

**TYPE EHS-2**

## Disposable glove dispenser



- Capacity: 2 cardboard boxes  
(Cardboard box: 210 x 120 x 60 mm)
- Spring mechanism
- Filling through lid in pitched roof version
- Lid with overhang, advantage:  
No risk of finger pinching

TYPE	VERSION	DIMENSIONS W x D x H in mm	ARTICLE NO.
EHS-2	Wall-mounted	260 x 170 x 450/ 550	18.00.01.56

**TYPE EHS-3**

## Disposable glove dispenser



- Capacity: 3 cardboard boxes  
(Cardboard box: 210 x 120 x 60 mm)
- Spring mechanism
- Filling through lid in pitched roof version
- Lid with overhang, advantage:  
No risk of finger pinching

TYPE	VERSION	DIMENSIONS W x D x H in mm	ARTICLE NO.
EHS-3	Wall-mounted	390 x 170 x 450/ 550	18.00.01.57

**TYPE HSS-2**

## Glove dispenser



- Robust, open design
- For wall mounting using 2 holes:  
Ø 4mm
- Edged stainless steel sheet, 1 mm
- Cardboard insert at the side
- Capacity: 1 cardboard box  
(Cardboard box: 222 x 125 x 74 mm)

TYPE	VERSION	DIMENSIONS W x D x H in mm	ARTICLE NO.
HSS-2	wall-mounted	223 x 127 x 76	18.00.00.49

**TYPE HSD**

## Glove dispenser



- Capacity depending on the relevant version: 1 to 3 cardboard boxes
- For wall mounting, Ø 8 mm
- Robust wire-mesh version
- Other capacities on request!

TYPE	CAPACITY	DIMENSIONS W x D x H in mm	ARTICLE NO.
HSD-I	1 cardboard box	288 x 113 x 145	18.00.02.82
HSD-II	2 cardboard boxes	288 x 113 x 260	18.00.02.81
HSD-III	3 cardboard boxes	288 x 113 x 375	18.00.00.76
HSD-IV	4 cardboard boxes	288 x 113 x 485	18.00.03.76

**TYPE ESS-1**

## Disposable apron dispenser



- Hygienic-Design
- With hygienic wall bracket
- For blocked disposable aprons with tear-off edge
- Stable profile pipe, 4 sliding hooks

TYPE	VERSION	DIMENSIONS W x D x H in mm	ARTICLE NO.
ESS-1	Wall-mounted	450 x 85 x 70	18.00.01.58

**TYPE ESS-2**

## Disposable apron dispenser



- Hygienic-Design
- With hygienic wall bracket
- For disposable aprons on a roll with tear-off edge
- With rounded inner body
- Including drain holes

TYPE	VERSION	DIMENSIONS W x D x H in mm	ARTICLE NO.
ESS-2	Wall-mounted	400 x 100 x 50/ 80	18.00.01.59

**TYPE EBS**

## Prot. goggles, face mask dispenser



- For disposable full-view protective goggles and Face masks in the production area
- Filling through lid in pitched roof version
- Lid with overhang, advantage: No risk of finger pinching
- Large withdrawal opening

TYPE	VERSION	DIMENSIONS W x D x H in mm	ARTICLE NO.
EBS	Wall-mounted	200 x 170 x 450/ 550	18.00.01.53

**TYPE US**

## Utensil dispenser



- Spacious interior for hygienic storage
- Filling through lid with pitched roof
- Lid with overhang, advantage: No risk of finger pinching
- Large withdrawal opening
- Splash-proof

TYPE	VERSION	DIMENSIONS W x D x H in mm	ARTICLE NO.
US	Wall-mounted	300 x 280 x 150/250	18.00.01.38
US-T	with separation wall	300 x 280 x 150/250	18.00.01.69
US-2	with separation wall	605 x 280/300 x 150/250	18.00.01.33
US-3	with separation wall	905 x 280/300 x 150/250	18.00.01.34

**TYPE EMS**

## Hairnet-, face mask dispenser



- For hairnets, face masks, overshoes, beard protectors or earplugs
- Filling through lid with pitched roof
- Lid with overhang, advantage: No risk of finger pinching
- Large withdrawal opening
- Optional with separation wall

TYPE	VERSION	DIMENSIONS W x D x H in mm	ARTICLE NO.
EMS	without sep. wall	400 x 175 x 450/ 550	18.00.01.54
EMS-TW	with separation wall	400 x 175 x 450/ 550	18.00.01.36
EMS-Mini	without sep. wall	200 x 175 x 450/ 550	18.00.00.90
EMS-Mini-TW	with separation wall	200 x 175 x 450/ 550	18.00.01.37



US-2 - inside, equipped



US-3 - inside, equipped

**OPTION: LABELLING SERVICE - ETCHING**

Labelling or symbols as required Article no. 90.00.00.94



### TYPE EBS-M

## Disposable face mask dispenser



- For disposable face masks for infection protection
- Hygienic-Design
- Filling through lid in pitched roof version
- Lid with overhang, advantage: No risk of finger pinching
- Large withdrawal opening

TYPE	VERSION	DIMENSIONS W x D x H in mm	ARTICLE NO.
EBS-M	Wall-mounted	200 x 170 x 450/550	18.00.01.53

### TYPE MSS

## Disposable face mask dispenser



- For disposable face masks for infection protection
- Open wall-mounted version
- Simple installation using 2 keyhole drillings
- Large withdrawal opening
- Material thickness 1.5 mm

TYPE	VERSION	DIMENSIONS W x D x H in mm	ARTICLE NO.
MSS	Wall-mounted/open	200 x 110 x 110	18.00.01.21

### TYPE EKS

## Coat, overall, bonnet dispenser



- For disposable visitor coats, overalls or straw hoods (Packing size up to W 250 x D 310 mm)
- Filling through lid with pitched roof
- Lid with overhang, advantage: No risk of finger pinching
- Large withdrawal opening

TYPE	VERSION	DIMENSIONS W x D x H in mm	ARTICLE NO.
EKS	Wall-mounted	260 x 320 x 450/ 550	18.00.01.55

### TYPE MMS

## Disposable Multi-Mix Dispenser



- Capacity: 2x gloves, 1x hairnet or face mask
- Filling through lid with pitched roof
- Lid with overhang, advantage: No risk of finger pinching
- With or without hook rail for blocked disposable aprons

TYPE	VERSION	DIMENSIONS W x D x H in mm	ARTICLE NO.
MMS-I	without hook board	600 x 170 x 450/ 500	18.00.00.10
MMS-II	with hook board	600 x 170 x 550/ 600	18.00.01.16

### TYPE HD-WA

## HD-wall spacer



Provides space for the cleaning behind the housing as well!

- Hygienic-Design
- Solid material, round or flat steel
- Wall distance: 50 or 100 mm

TYPE	VERSIONS	DIMENSIONS D/W x D x H mm	ARTICLE NO.
HD-WA 50-R	Solid material round+seal	D 30 x 50	99.80.06.00
HD-WA 50-M	Solid material round	D 30 x 50	99.80.06.03
HD-WA 100-D	Solid material round	D 37 x 100	99.80.06.02
HD-WA 50-FS	Flat steel	W 40 x 50 x 81	99.80.02.67
HD-WA 100-FS	Flat steel	W 40 x 100 x 81	99.80.03.09



Solid material round

**TYPE MSH**

## Garbage bag holder



- Capacity: 110/120 ltr. Garbage bags
- Locking of the garbage bag with hinged stainless steel ring
- Lid opening by foot pedal [only MSH-S-I]
- Optional: Base plate for heavy filler

TYPE	VERSION	DIMENSIONS W x D x H in mm	ARTICLE NO.
MSH-S-I	Stand, with lid+ footpedal	513 x 563 x 1107	49.00.02.51
MSH-S-II	Stand <sup>1</sup>	498 x 521 x 1007	49.00.02.52
MSH-W-III	Wall, with lid <sup>2</sup>	417 x 520 x 160	49.00.02.53
MSH-W-VI	Wall*	385 x 477 x 140	49.00.02.56

<sup>1</sup>without lid, <sup>2</sup>without foot pedal

**OPTIONS**

Base plate Ø 400only for MSH-S I + II Article no. 49.00.01.33

**TYPE ESP**

## Stainless steel mirror



- Ultrafinish surface
- Break-proof (IFS-compliant)
- All sides chamfered
- Rear side fully backfilled with Forex panel
- Total thickness: 6 mm

TYPE	VERSION	DIMENSIONS W x D x T in mm	ARTICLE NO.
ESP-I	pre-drilled	500 x 600 x 6	49.00.09.81
ESP-II	pre-drilled	1000 x 600 x 6	49.00.09.82
ESP-III	pre-drilled	1500 x 600 x 6	49.00.09.83
ESP-IV	pre-drilled	500 x 400 x 6	49.00.09.33
ESP-V	undrilled	500 x 600 x 6	49.00.19.81
ESP-VI	undrilled	1000 x 600 x 6	49.00.19.82
ESP-VII	undrilled	1500 x 600 x 6	49.00.19.83
ESP-VIII	undrilled	500 x 400 x 6	49.00.19.33

**OPTIONS**

Special ESP-S mirror screws with pointed caps incl. grub screw [4 pcs.] Article no. 20.00.10.06

Mirror clamps ESP-K [4 pcs.] Article no. 20.00.10.09

Customised sizes between 2,488 x 12.38 mm [with Forex backfill] or available as a pure mirror sheet [1.00 mm] measuring 2,500 x 1250 mm

**TYPE PK-D/ PF-E**

## Paper baskets



- Stable industrial version
- Stainless steel wire mesh [PK-D]
- Stainless steel sheet metal [PK-E]
- PK-E: Inclined bottom with drain holes

TYPE	CAPACITY	DIMENSIONS W x D x H in mm	ARTICLE NO.
PK-D 40	40 litres	350 x 250 x 400	18.00.00.28
PK-D 60	60 litres	410 x 270 x 580	18.00.00.62
PK-D 100	100 litres	420 x 345 x 750	18.00.00.63
PK-E 40	40 litres	335 x 255 x 450	18.00.01.24
PK-E 60	60 litres	410 x 270 x 580	18.00.01.25
PK-E 100	100 litres	400 x 340 x 700	18.00.01.26

**OPTIONS**

Wall bracket Article no. 18.00.09.97

**TYPE HS**

## Hygienic shelves



- For attaching commercially available manual wetting devices
- 3 different versions available
- Robust stainless steel floor model
- Maximum mounting width: 220 mm / 350 mm / 400 mm [depending on the type]

TYPE	MAX. MOUNTING WIDTH	DIMENSIONS W x D x H in mm	ARTICLE NO.
HS 22/140	250 mm	350 x 350 x 1400	18.00.04.95
HS 35/160	350 mm	480 x 530 x 1600	18.00.04.96
HS 40/160	450 mm	530 x 530 x 1600	18.00.04.97

**OPTION: LABELLING SERVICE - ETCHING**

Labelling or symbols as required Article no. 90.00.00.94



**MORE INFO**

**TYPE DESIPOWER V**

## Hand disinfection, automatic

STAINLESS STEEL 1.4301



Desipower-V with optional hygienic shelf and mobile kit

- For wall mounting using a suspension rail
- Disinfection takes place via an atomiser nozzle
- Spray cones cover the entire surface of both hands
- Generous opening for sanitising both hands
- Individual adjustable dosage
- Lockable housing
- Capacity: up to 5 litres Container possible [without container]
- 12 V battery operation [GEL battery] with charger
- When the hands are inserted, the sensor triggers a spray shot with the set application quantity via 1 fine atomiser nozzle.

TYPE	VERSION	DIMENSIONS W x D x H in mm	ARTICLE NO.
Desipower V	1 nozzle	360 x 230 x 540	10.00.15.16

**OPTION**

Hygienic shelf	Article no. 18.00.04.97
Mobile kit consisting of handle bar and 2 castors	Article no. 10.00.15.08

**TYPE HTW**

## Hygiene separation wall

STAINLESS STEEL 1.4301



- Hygienic stainless steel U-profile frame
- Standing height: 1,950 mm
- Makrolon disc: Width: 600 mm
- Makrolon disc fixed with stainless steel swivel hinges
- Disc can be replaced quickly and without tools
- Stand foot depth: 500 mm

The hygiene separation wall allows for a swift, easy, and hygienic separation of individuals to prevent droplet infections. Separation walls can be used in retail, by service providers and restaurants, in public buildings, medical areas, and other care facilities.

For instance, they serve to protect customers and employees from each other, as well as patients, visitors, and medical staff in hospitals. The lightweight design makes the separation wall mobile, while the construction remains exceptionally stable and robust. The Makrolon pane is translucent and allows for visibility in both directions.

TYPE	VERSION	DIMENSIONS W x D x H in mm	ARTICLE NO.
HTW-S 60/195	-	600 x 500 x 1950	18.00.00.13

**TYPE INFS/40-160**

# Infection Protection Station

STAINLESS STEEL 1.4301



**Robust stainless steel stand model, stand height 1,600 mm, consisting of as standard:**

- Hygienic shelf Type HS-40/160
- Disinfectant dispenser Type USP-0 with drip tray
- Face mask dispenser Type EBS-M
- Paper basket made of stainless steel wire mesh [capacity 40 litres]
- Stand foot depth: 530 mm
- Material thickness: 1.5 mm [rear panel] / 2.0 mm [stand]
- Maximum mounting width: 400 mm
- Other versions or dispensers possible [see accessories]

**DESCRIPTION**

This "Access Column" is immediately ready for the implementation of the intensified hygiene measures and available for prompt delivery.

- Stainless steel functional disinfectant dispenser with arm lever operation and refillable plastic container [Volume: 1,000 ml]
- Drip tray [collection pan] beneath the hand disinfectant dispenser
- Hygienic face mask dispenser [W 200 x D 170 x H 450/550] in Hygienic-Design version
- Stainless steel waste basket [40 litres] for hygienic disposal of used face masks [W 350 x D 250 x H 400 mm]
- Optionally available with mandatory sign "Wear face mask" and/or "Disinfect hands". Further mandatory signs on request!

It is supplied fully assembled so that the infection control station is ready for immediate use.

TYPE	VERSION	DIMENSIONS W x D x H in mm	ARTICLE NO.
INFS/40-160	Floor model*	530 x 530 x 1600	18.00.05.50

\* Disinfection / face mask / waste bin  
Other designs or fittings on request!

**TYPE RH-W**

**Roll holder**

STAINLESS STEEL 1.4301



- Robust tubular frame
- For wall mounting
- With stainless steel round core
- For standard cleaning rollers (W: 220 mm)

TYPE	VERSION	DIMENSIONS W x D x H in mm	ARTICLE NO.
RH-W	wall-mounted	300 x 280 x 380	18.00.00.99

**TYPE RH-W2**

**Roll holder**

STAINLESS STEEL 1.4301



- Hygienic round tube frame
- Mobile with 2 polyamide wheels Ø 150 mm
- Stainless steel round core Ø 25 x 2.0 mm
- For holding commercially available disposable towel rolls

TYPE	VERSION	DIMENSIONS W x D x H in mm	ARTICLE NO.
RH-W 2	wall-mounted	510 x 452 x 475	19.00.00.99





**TYPE RH-S1**

**Roll holder**

STAINLESS STEEL 1.4301



- Hygienic round tube frame
- Mobile with 2 polyamide wheels Ø 150 mm
- Stainless steel round core Ø 25 x 2.0 mm
- For holding commercially available disposable towel rolls

TYPE	VERSION	DIMENSIONS W x D x H in mm	ARTICLE NO.
RH-S 1	Floor stand	510 x 850 x 430	19.00.00.98



01

**TYPE RH-SF1**

**Roll holder**

STAINLESS STEEL 1.4301



- Hygienic round tube frame
- Mobile with 2 polyamide wheels Ø 150 mm
- Stainless steel round core Ø 25 x 2.0 mm
- For holding commercially available disposable towel rolls
- Incl. garbage bag holder: Locking mechanism with hinged stainless steel ring

TYPE	VERSION	DIMENSIONS W x D x H in mm	ARTICLE NO.
RH-SF 1	Mobile*	460/ 585 x 850 x 825	19.00.00.97



\*Mobile floor stand with garbage bag holder

## Hygiene walls, wall-mounted



## Hygiene wall 2.0

Customise your hygiene wall precisely to your requirements!



## Hygiene walls, with stand

STAINLESS STEEL 1.4301



01

### All information and options

Find out more at:  
<https://bit.ly/43d6p07>

**25**  
YEARS  
EXPERIENCE

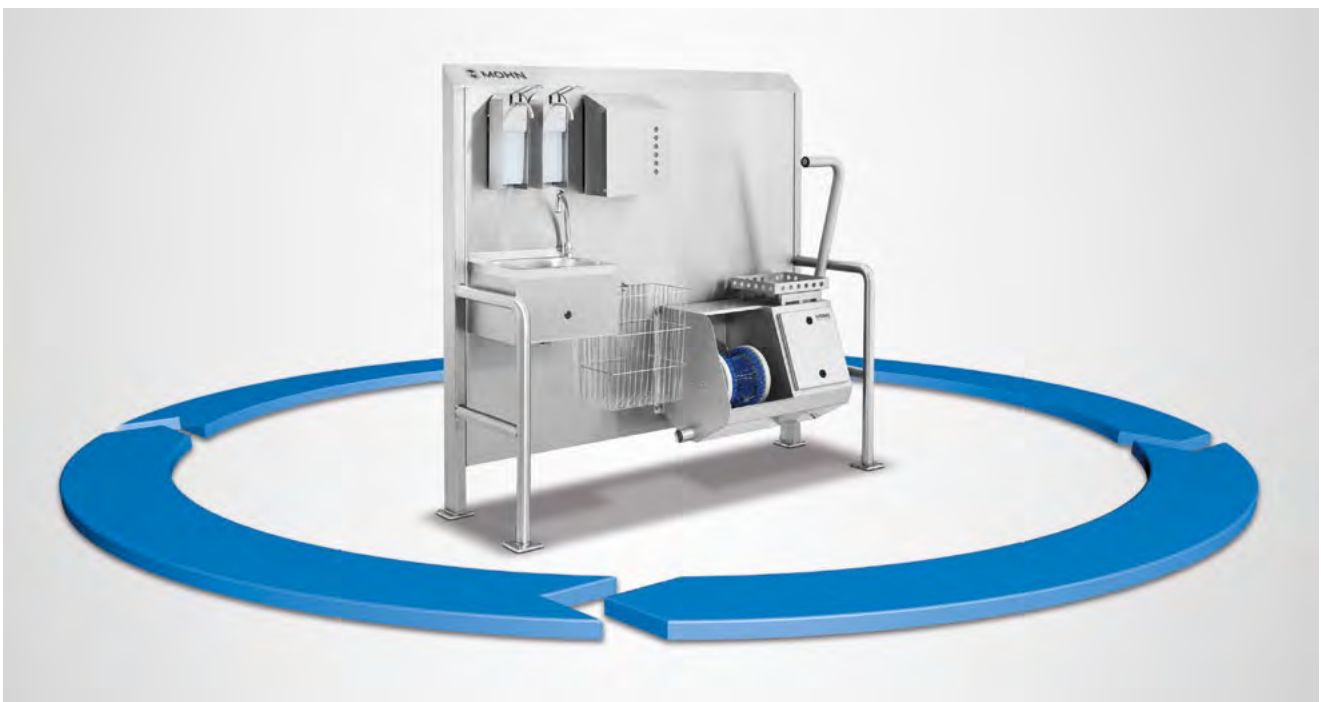

**TYPE HW-S**

# Hygiene wall

STAINLESS STEEL 1.4301



**COMPLETE UNIT CONSISTING OF:**

- 1 Hand basin (HWB-S 47), sensor operation
- 2 Universal dispenser (USP-0) for soap + disinfectant
- 1 Towel dispenser (HTSP-0)
- 1 Wire-mesh paper basket (PK-D 40)
- Rear with pitched roof (Hygienic-Design) incl. suspension rail
- Mirror-inverted design available (arrangement on request)

TYPE	VERSION	DIMENSIONS W x D x H in mm	ARTICLE NO.
HW-S	Sensor HWB	760 x 500 x 1100	11.00.01.19

**TECHNICAL DATA**

Mains supply	230 V; 50/60 Hz
Voltage	24 V/DC
Water connection	1/2" - KW/WW
Drain	1 1/2"

**OPTIONS**

Stand feet	Article no. 18.00.01.79
Knee operation hand wash basin	Article no. 11.00.01.18

**TYPE HW-HWB HL1**

# Hygiene wall

STAINLESS STEEL 1.4301

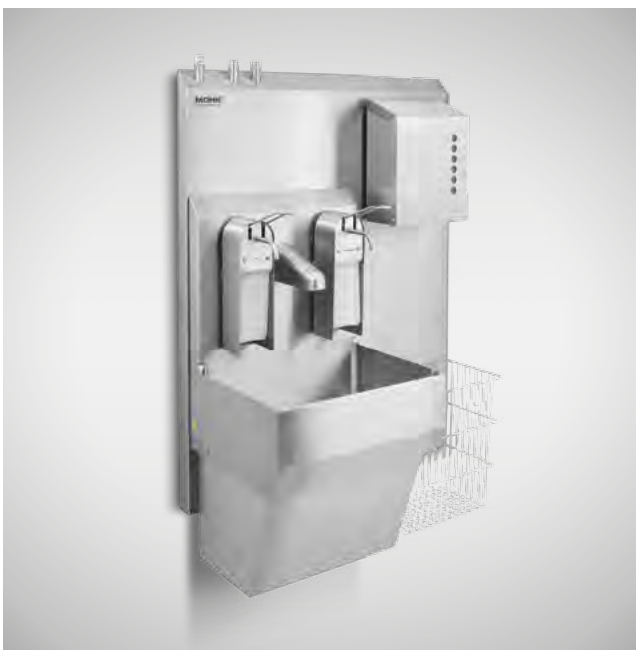

Version with optimal media facing and supply from above

**COMPLETE UNIT CONSISTING OF:**

- 1 hand basin (HWB HL 1), sensor operation
- 2 Universal dispenser (USP-0) for soap + disinfectant
- 1 Towel dispenser (HTSP-0)
- 1 Wire-mesh paper basket (PK-D 40)
- Rear with pitched roof (Hygienic-Design) incl. suspension rail
- Mirror-inverted design available (arrangement on request)

TYPE	VERSION	DIMENSIONS W x D x H in mm	ARTICLE NO.
HW-HWB-HL 1	Sensor HWB-HL 1	960 x 460 x 1100	11.00.00.37

**TECHNICAL DATA**

Mains connection	230 V; 50/60 Hz
Voltage	24 V/DC
Water connection	1/2" - KW/WW
Drain	1 1/2"

**OPTION**

Stand feet	Article no. 18.00.01.79
------------	-------------------------

**TYPE HW-J**

## Hygiene wall

STAINLESS STEEL 1.4301



**COMPLETE UNIT CONSISTING OF:**

- 1 Hand basin (HWB-S 47), sensor operation
- 2 Universal dispenser (USP-0) for soap + disinfectant
- Electric 2-hand high performance hand drier Type Jet II
- Rear with pitched roof (Hygienic-Design) incl. suspension rail
- Mirror-inverted design available (arrangement on request)

TYPE	VERSION	DIMENSIONS W x D x H in mm	ARTICLE NO.
HW-J	Sensor HWB+Jet II	960 x 500 x 1100	11.00.00.42

**TECHNICAL DATA**

Mains supply	230 V; 50/60 Hz
Voltage	24 V/DC
Power	3.2 kW
Water connection	1/2" - KW/WW
Drain	1 1/2"

**OPTION**

Stand feet	Article no. 18.00.01.79
------------	-------------------------

**TYPE HW-I**

## Hygiene wall

STAINLESS STEEL 1.4301



**COMPLETE UNIT CONSISTING OF:**

- 1 Hand basin (HWB-S 40), sensor operation
- 2 Universal dispenser (USP-0) for soap + disinfectant
- 1 Towel dispenser (HTSP-0)
- 1 Wire-mesh paper basket (PK-D 40)
- Sole cleaning machine (Sole-Master)
- Rear with pitched roof (Hygienic-Design) including foot frame
- Mirror-inverted design available (arrangement on request)

TYPE	VERSION	DIMENSIONS W x D x H in mm	ARTICLE NO.
HW-I	Floor model, right	1570 x 525 x 1700	11.00.00.44
HW-I	Floor model, left	1570 x 525 x 1700	11.00.00.43

**TECHNICAL DATA**

Mains supply	230 V; 50/60 Hz
Power	0.2 kW
Water connection	3/4" - MW, 1/2" - WW/ KW
Drain	2"

Version: rechts

**TYPE H-RW**

# Hygiene rear panel

STAINLESS STEEL 1.4301



- Rear with pitched roof (Hygienic-Design)
- Reinforced on the back with 2 longitudinal hat profiles
- Wall-mounted version with mounting rail and left and right with 2 holes each in all joists, Ø 31.7mm

TYPE	VERSION	DIMENSIONS W x D x H in mm	ARTICLE NO.
H-RW 135-110	wall-mounted	1350 x 50 x 1100/1150	11.00.00.28
H-RW 76-110	wall-mounted	760 x 50 x 1100/1150	11.00.00.29
H-RW 96-110	wall-mounted	960 x 50 x 1100/1150	11.00.00.39

Other dimensions on request

Type H-RW 76-110



Type H-RW 76-110 Rear side



**TYPE H-RW/S**

# Hygiene rear panel

STAINLESS STEEL 1.4301



- Rear with pitched roof (Hygienic-Design)
- Reinforced on the back with 2 longitudinal hat profiles
- Stand frame with round tube profile railing Ø 42.4 mm
- Railing height: 800 mm, knee strap at 400 mm height
- Ground clearance: 160 mm, 4 height-adjustable floor fixing brackets

TYPE	VERSION	DIMENSIONS W x D x H in mm	ARTICLE NO.
H-RW/S 157-170	Stand frame	1570 x 490 x 1700	11.00.00.36

Other dimensions on request

**TYPE EC**

# Euroclean-Complete

STAINLESS STEEL 1.4301



Typ EC-S Jet

The compact hygiene complete solution for craft, low-frequented side entrances or technical departments

- Optionally with base frame or wall-mounted
- Sensor hand wash basin\*
- 2 Universal dispensers for disinfectant and soap
- Towel dispenser [HTSP-0] for folded paper towels
- Sole cleaning machine, Type Sole-Master
- Can bracket + waste paper basket made of wire [PK-D 40]

TYPE	VERSION	DIMENSIONS	ARTICLE NO.
		W x D x H in mm	
EC-S	Floor model	684 x 453 x 1600	11.00.00.22
EC-W	wall-mounted	684 x 400 x 1500	11.00.00.23
EC-S Jet	Floor model + Jet-II	1000 x 460 x 1600	11.00.00.34

**TECHNICAL DATA**

Mains supply	230 V; 50/60 Hz
Power	0.2 kW [ES-S Jet: 3.4 kW]
Water	1/2"
Drain	2"



Type EC-S



**TYP HS-I + II**

## Hygienic station

STAINLESS STEEL 1.4301



Type HS-II

The compact stationary hygienic complete solution for optimum Cleaning and disinfection of hands and soles by Forced control or forced sequence control.

- 2-Hand disinfection unit
- Contactless fittings for soap, water, disinfection
- Automatic sole cleaning
- Type HS-I with towel dispenser (HTSP-0), paper basket (PK-D 40)
- Type HS-II with hand drier, Type Jet-I
- Tamper-proof Siemens Logo control unit, freely programmable
- Multi-LED signal display

TYPE	VERSION	DIMENSIONS W x D x H in mm	ARTICLE NO.
HS-I	HTSP-0+PK-D40	1025 x 850/ 1155 x 1995	11.10.07.66
HS-II	Jet-I	1025 x 850/ 1155 x 1995	11.10.07.67

**TECHNICAL DATA**

Mains supply	3x 400 V; 50/60 Hz
Voltage	24 V/DC
Power	0.6 kW [HS-II: 2.2 kW]
Water connection	3/4" - MW
Drain	2"

**TYP HS-III**

## Hygienic station

STAINLESS STEEL 1.4301



Type HS-III with optional document tray

The compact stationary hygienic complete solution for optimum Cleaning and disinfection of hands and soles by Forced control or forced sequence control.

- 2-Hand disinfection unit
- Contactless fittings for soap, water, disinfection
- Automatic sole cleaning
- Tamper-proof Siemens Logo control unit, freely programmable
- with electric hand dryer
- Multi-LED signal display

TYPE	VERSION	DIMENSIONS W x D x H in mm	ARTICLE NO.
HS-III Highline	Railing frontal	1460 x 933 x 1995	11.10.07.68

**TECHNICAL DATA**

Mains supply	3x 400 V; 50/60 Hz
Voltage	24 V/DC
Power	2.2 kW
Water connection	3/4" - MW
Drain	2"

**TYPE DESIPOWER V**

## Hand disinfection

STAINLESS STEEL 1.4301



- Suitable for use wherever hand disinfection is required
- For wall mounting using a suspension rail
- Disinfection takes place via an atomiser nozzle
- Spray cone covers the entire surface of the hands
- Generous opening for sanitising both hands
- Individual adjustable dosage
- Lockable housing
- Capacity: up to 5 litres Container possible (without container)
- 12 V battery operation (GEL battery) with charger or mains operation

TYPE	VERSION	DIMENSIONS W x D x H in mm	ARTICLE NO.
Desipower V	1 nozzle, battery	360 x 230 x 540	10.00.15.16
Desipower V	1 nozzle, mains	360 x 230 x 540	10.00.15.17

**TECHNICAL DATA**

Operating voltage 12 V (GEL battery) or 230 V

**OPTION**

Pedestal frame Article no. 18.00.04.97

**TYPE DESIPOWER III**

## Hand disinfection

STAINLESS STEEL 1.4301



- Suitable for use wherever hand disinfection is required
- An optional potential-free contact is available, for instance, for the control of a client-side door
- For wall mounting
- Lockable canister storage
- Individual adjustable dosage
- Capacity up to 5 litres Disinfectant
- Large opening for sanitising both hands
- 2 spray cones cover the entire surface of both hands

TYPE	VERSION	DIMENSIONS W x D x H in mm	ARTICLE NO.
Desipower III	2 nozzles	310 x 278* x 605	10.00.15.03

\* incl. wall mounting rail

**TECHNICAL DATA**

Mains supply 230 V; N/PE; 50 Hz

Power 50 W

Weight 6 kg

**OPTIONS**

potential-free contact Article no. 12.00.00.58

Pedestal frame Article no. 18.00.04.97

**TYPE SOAP-STAR ECOLINE, DESI-STAR ECOLINE**

## Disinfection or soap dispenser

STAINLESS STEEL 1.4301



For controlled 2-hand application by integrated control unit. Potential-free contact for controlling of, for example, door provided by the customer

- Hygienic-Design
- Wall-mounted version
- Tamper-proof 2-hand sensor control
- Multi-LED signal display
- Incl. can bracket and scrap collection container

TYPE	VERSION	DIMENSIONS W x D x H in mm	ARTICLE NO.
Soap-Star	Soap	400 x 345 x 575*	11.10.08.06
Desi-Star	Disinfection	400 x 345 x 575*	11.10.08.07

\* Dimensions without can bracket and scrap collection container

### TECHNICAL DATA

Mains supply	230 V; 50/60 Hz
Power	0.2 kW
Voltage	24 V/DC

**TYPE DESI-STAR HIGHLINE, SOAP-STAR HIGHLINE**

## Disinfection or soap dispenser

STAINLESS STEEL 1.4301



Type Desi-Star Highline, wall-mounted

- Hygienic-Design
- Wall-mounted version
- Tamper-proof 2-hand sensor control
- Full cone jet nozzles for large-area wetting
- Potential-free contact available, e.g. for electric door opener
- Lockable canister storage compartment
- Multi-LED signal display
- Optical canister emptying

TYPE	VERSION	DIMENSIONS W x D x H in mm	ARTICLE NO.
Desi-Star	wall-mounted disinfection	405 x 310 x 920	10.00.02.22
Desi-Star A*	wall-mounted desi. + alarm*	953 x 310 x 920	10.00.22.22
Soap-Star	wall-mounted soap	405 x 310 x 920	10.00.22.21
Soap-Star A*	wall-mounted soap + alarm*	953 x 310 x 920	10.00.33.31

\*Alarm function with 2 sensors + 1 horn

### TECHNICAL DATA

Mains supply	230 V; N/PE; 50/60 Hz
Operating voltage	24 V/DC
Power	0.1 kW

### OPTION

Pedestal frame	Article no. 12.00.00.48
----------------	-------------------------

**TYPE CS-T, CSD-T ECOLINE**

# Clean-Station

STAINLESS STEEL 1.4301



Picture 1: Type CS-T WL, picture 2: Type CSD-T WR

For controlled cleaning, drying and disinfection of the hands through forced sequence by integrated controller. Potential-free contact for controlling of, for ex. rapid-action gate, door etc.

- Hygienic design; high-speed hand dryer 3.2 kW
- Wash trough with touchless fittings for water and soap
- Sensor-controlled 2-hand hand disinfection unit; Type CSD-T with electric turnstile

TYPE	VERSION	DIMENSIONS W x D x H in mm	ARTICLE NO.
CS-T WR	Wall, right	1553 x 375 x 800	11.10.08.34
CS-T WL	Wall, left	1553 x 375 x 800	11.10.08.35
CS-T SR	Floor-mounted, right	1553 x 375 x 1625	11.10.08.36
CS-T SL	Floor-mounted, left	1553 x 375 x 1625	11.10.08.37
CSD-T WR	Wall, right	1553 x 864 x 800	11.10.08.26
CSD-T WL	Wall, left	1553 x 864 x 800	11.10.08.27
CSD-T SR	Floor-mounted, right	1553 x 864 x 1625	11.10.08.28
CSD-T SL	Floor-mounted, left	1553 x 864 x 1625	11.10.08.29

**TECHNICAL DATA**

Mains supply	230 V; 50/60 Hz	Water connection	3/4" - MW
Power	3.4 kW	Drain	1 1/2"

**TYPE CS, CSD ECOLINE**

# Clean-Station

STAINLESS STEEL 1.4301



Type CSD-WR with turnstile

For controlled cleaning, drying and disinfection of the hands through forced sequence by integrated controller with person separation. Potential-free contact for controlling of, for ex. rapid-action gate, door etc.

- Wash trough with touchless fittings for water and soap
- Paper basket 40 litres (PK-D) and towel dispenser (HTSP-0)
- Sensor-controlled 2-hand disinfection unit; Type CSD with electric turnstile

TYPE	VERSION	DIMENSIONS W x D x H in mm	ARTICLE NO.
CS-WR	Wall, right	1153 x 375 x 575	11.10.08.30
CS-WL	Wall, left	1153 x 375 x 575	11.10.08.31
CS-SR	Floor-mounted, right	1153x 375 x 1385	11.10.08.32
CS-SL	Floor-mounted, left	1153x 375 x 1385	11.10.08.33
CSD-WR	Wall, right	1153 x 864 x 575	11.10.08.22
CSD-WL	Wall, left	1153 x 864 x 575	11.10.08.23
CSD-SR	Floor-mounted, right	1153 x 864 x 1385	11.10.08.24
CSD-SL	Floor-mounted, left	1153 x 864 x 1385	11.10.08.25

**TECHNICAL DATA**

Mains supply	230 V; 50/60 Hz	Water connection	3/4" - MW
Voltage	24 V/DC	Drain	1 1/2"

**TYPE CSD HIGHLINE**

# Clean-Station

STAINLESS STEEL 1.4301



Type CSD-WL

For controlled cleaning, drying and disinfection of the hands through forced sequence by integrated controller with person separation.

- Wash trough with touchless fittings for water and soap
- Waste paper basket 40 litres (PK-D) & towel dispenser (HTSP-0)
- 2-hand disinfection machine incl. vandal-proof turnstile
- Siemens Logo control unit, freely programmable

TYPE	VERSION	DIMENSIONS W x D x H in mm	ARTICLE NO.
CSD-WR	Wall, right	1453 x 965 x 600	11.10.07.22
CSD-WL	Wall, left	1453 x 965 x 600	11.10.07.23
CSD-SR	Floor-mounted, right	1453 x 965 x 1395	11.10.07.24
CSD-SL	Floor-mounted, left	1453 x 965 x 1395	11.10.07.25

**TECHNICAL DATA**

Mains supply	230 V; 50/60 Hz
Voltage	24 V/DC
Water connection	1/2" - MW
Drain	1 1/2"

01

**TYPE SOAP-, DESI-CONTROL ECOLINE**

**Automatic soap, disinfection unit with turnstile**

STAINLESS STEEL 1.4301



Ecoline, wall-mounted, left-hand version

Soap and disinfection unit with 2 years warranty\* - including board control

**PERSON SEPARATION**

Approval after terminated medium application only!

- Ecoline version with stable turnstile [2 years warranty\*]
- incl. circuit board control, potential-free contact available
- Return path electrically enabled or permanently blocked
- Dosage of the application quantity adjustable

*\*for the turnstile mechanism!*

TYPE	VERSION	DIMENSIONS W x D x H in mm	ARTICLE NO.
Soap-Control	Wall, right	653 x 875 x 575	11.10.08.01
	Wall, left	653 x 875 x 575	11.10.08.02
	Floor-mounted, right	653 x 875 x 1385	11.10.08.03
	Floor-mounted, left	653 x 875 x 1385	11.10.08.04
Desi-Control	Wall, right	653 x 875 x 575	11.10.08.08
	Wall, left	653 x 875 x 575	11.10.08.09
	Floor-mounted, right	653 x 875 x 1385	11.10.08.10
	Floor-mounted, left	653 x 875 x 1385	11.10.08.11

**TECHNICAL DATA**

Mains supply	230 V; 50/60 Hz
Control voltage	24 V/DC
Power	0.2 kW

**OPTIONS**

Document tray, Type DA-III [Wall-mounted by means of 2 holes. With optional brackets also suitable for mounting on railings or cover housing]	Article no. 18.00.03.94
Optical empty-can message by multi-LED	Article no. 99.87.00.34
Handrail for forced guidance of persons	see page 80
Can bracket in closed, lockable version	see page 183

**WALK-THROUGH DIRECTIONS**

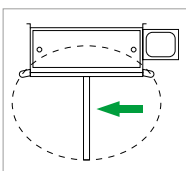

Right-hand version

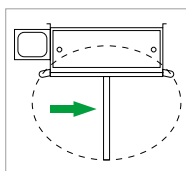

Left-hand version

**TYPE SOAP-, DESI-CONTROL HIGHLINE**

# Automatic soap, disinfection unit with turnstile

STAINLESS STEEL 1.4301

01



Highline, left-hand wall version

Soap and disinfection unit with 10 years warranty\* - including freely programmable Siemens Logo control unit

**PERSON SEPARATION**

Approval after terminated medium application only!

- Highline version with vandalism-proof turnstile [10 years warranty\*]
- Including freely programmable Siemens Logo control unit
- Encapsulated IP68 sensor for end position detection of the turnstile
- Tamper-proof sensor technology
- Return path electrically enabled or permanently blocked
- Dosage of the application quantity adjustable
- Optical empty-can message by multi-LED
- Version with drop-arm turning lock, see 73

*\*for the turnstile mechanism!*

TYPE	VERSION	DIMENSIONS W x D x H in mm	ARTICLE NO.
Soap-Control	Wall, right	1053 x 935 x 600	11.10.07.01
	Wall, left	1053 x 935 x 600	11.10.07.02
	Floor-mounted, right	1053 x 935 x 1410	11.10.07.03
	Floor-mounted, left	1053 x 935 x 1410	11.10.07.04
Desi-Control	Wall, right	1053 x 935 x 600	11.10.07.08
	Wall, left	1053 x 935 x 600	11.10.07.09
	Floor-mounted, right	1053 x 935 x 1410	11.10.07.10
	Floor-mounted, left	1053 x 935 x 1410	11.10.07.11

**TECHNICAL DATA**

Mains supply	230 V; 50/60 Hz
Control voltage	24 V/DC
Power	0.2 kW

**OPTIONS**

Document tray, Type DA-III (Wall-mounted by means of 2 holes. With optional brackets also suitable for mounting on railings or cover housing)	Article no. 18.00.03.94
Handrail for forced guidance of persons	see page 80
Can bracket in closed, lockable version	see page 183

**WALK-THROUGH DIRECTIONS**

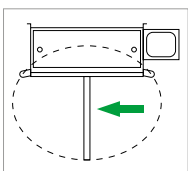

Right-hand version

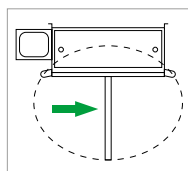

Left-hand version







**TYPE DUO-SOAP-, DESI-CONTROL HIGHLINE**

**Soap, Disinfection unit with Turnstile 2-lane**

STAINLESS STEEL 1.4301



01

**PERSON SEPARATION**

Approval after terminated medium application only!

- Vandalism-proof turnstile [10 years warranty\*]  
Including freely programmable Siemens Logo control unit
- Each lane separately controlled!
- Standing version in Hygienic-Design
- Tamper-proof sensor technology
- Return path electrically enabled or permanently blocked
- Dosage of the application quantity adjustable
- Optical empty-can message by multi-LED
- 2 can brackets
- Optional: 1-lane entry only / 1-lane exit only Article no. 10.00.32.30 [No need for 1 lane of soap or disinfectant application]
- Encapsulated IP68 sensor for end position detection of the turnstile
- Body length Duo-Soap, Duo-Desi: 1,200 mm
- Body length Duo-Soap 800, Duo-Desi 800: 800 mm

*\*for the turnstile mechanism!*

**TECHNICAL DATA**

Mains supply	230 V; 50/60 Hz
Control voltage	24 V/DC
Power	0.4 kW

Soap and disinfection unit with 10 years warranty\* - including freely programmable Siemens Logo control unit

TYPE	VERSION	DIMENSIONS W x D x H in mm	ARTICLE NO.
Duo-Soap 1200	2-lane hand soaping with turnstile	1710 x 1615 x 1474	11.10.07.05
Duo-Desi 1200	2-lane hand disinfection with turnstile	1710 x 1615 x 1474	11.10.07.12
Duo-Soap 800	2-lane hand soaping with turnstile	1310 x 1615 x 1474	11.10.07.98
Duo-Desi 800	2-lane hand disinfection with turnstile	1310 x 1615 x 1474	11.10.07.99

**OPTIONS**

Document tray, Type DA-III [Wall-mounted by means of 2 holes. With optional brackets also suitable for mounting on railings or cover housing]	Article no. 18.00.03.94
Handrail for forced guidance of persons	see page 80
Can bracket in closed, lockable version	see page 183
No disinfection or soap function for one track	Article no. 10.00.32.30

**TYPE DM**

# Disinfection mat

STAINLESS STEEL 1.4301



Walkable disinfection mat

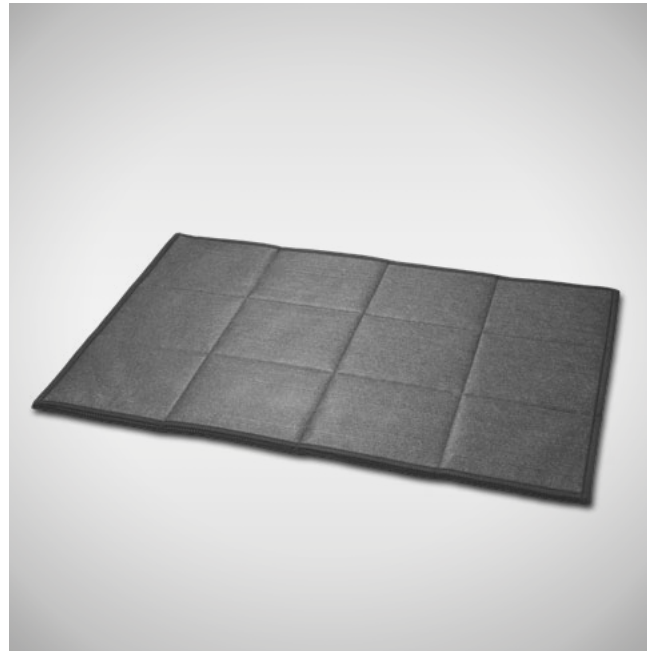

Passable disinfection mat quilted in squares

Simple, professional solution for safe and hygienic access to food-processing plants, canteens, pharmaceutical and bio-chemical enterprises etc.

- 6 different standard sizes (special sizes on request)
- 2 versions: Walkable (standard) or passable (quilted in squares)
- Durable and tough
- Individual lettering banners and logo embroideries on request

Disinfection mats quilted in squares are suited for the disinfection of passing-through rollers of trolleys, carts, lift trucks etc. passing over.

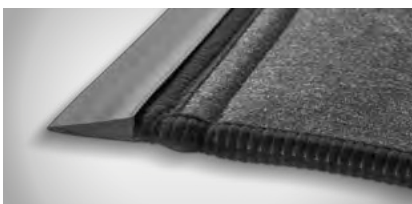

Disinfection mat with ramp



Passable disinfection mat quilted in squares

VERSION	TYPE	DIMENSIONS W x D x H in mm	ARTICLE NO.
Walkable (Standard)	DM-I	900 x 600 x 15	99.10.00.77
	DM-II	900 x 1200 x 15	99.10.00.81
	DM-III	900 x 1500 x 15	99.10.00.82
	DM-IV	900 x 1800 x 15	99.10.00.83
	DM-V	900 x 2400 x 15	99.10.00.85
	DM-VI	900 x 3000 x 15	99.10.00.84
Passable (quilted in squares)	DM-K I	900 x 600 x 15	99.10.01.77
	DM-K II	900 x 1200 x 15	99.10.01.81
	DM-K III	900 x 1500 x 15	99.10.01.82
	DM-K IV	900 x 1800 x 15	99.10.01.83
	DM-K V	900 x 2400 x 15	99.10.01.85
	DM-K VI	900 x 3000 x 15	99.10.01.84

**OPTIONS**

Logo embroidery	on request
On/off ramp made of solid rubber	Article no. 99.10.01.58

**TYPE DDB-S**

## Walk-through disinfection basin

STAINLESS STEEL 1.4301

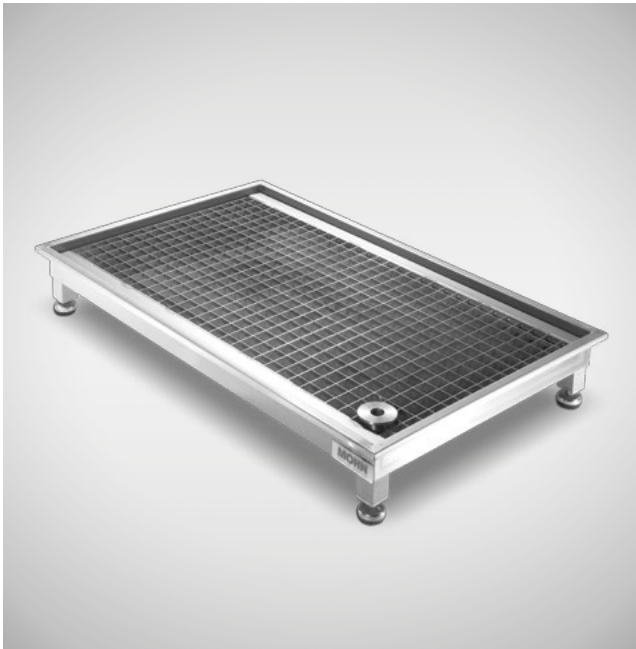

Walkable disinfection basin

For controlled walk-through disinfection of the soles.

- Floor version standing on vertically adjustable feet
- Stand pipe valve for drainage
- Removable anti-skid grid
- Optionally with dosing station

TYPE	VERSION	DIMENSIONS W x D x H in mm	ARTICLE NO.
DDB-S I	Floor version	1100 x 700 x 180	65.00.00.01
DDB-S II	Floor version	550 x 700 x 180	65.00.00.02

**TECHNICAL DATA**

Drain 2" [DN 50]

**OPTION**

Dosing station, Type DOS, wall-mounted Article no. 65.00.09.04

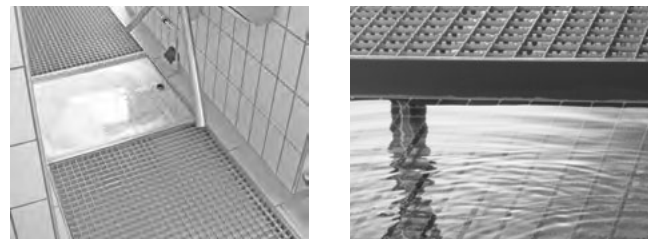

Versions: Ground-mounted variants and dosing stations [see page 46f]

**TYPE DDB-R**

## Mobile disinfection bath

STAINLESS STEEL 1.4301



- For disinfecting soles and wheels
- Robust and hygienic design
- Horizontal version without feet
- With on- and off-ramp
- Anti-slip, removable gratings
- Without drain nozzle
- One side 2 handles, other side 2 rigid casters made of polyamide
- Disinfection zone: L: 1,050 x W: 985 mm

TYPE	DISINFECTION ZONE W x D in mm	DIMENSIONS W x D x H in mm	ARTICLE NO.
DDB-R	1050 x 985	1100 x 1950 x 40/125	65.00.02.60

**TYPE DB-E**

**Disinfection basin**

STAINLESS STEEL 1.4301



For controlled walk-through disinfection of the soles.

Optionally with 1 or 2 drip-off zones [DB-E 2/ 3]

- Floor version, 2 different widths [700 and 1,200 mm]
- Removable overflow valve
- Removable anti-skid grids, MW 30 x 30
- Other dimensions on request

TYPE	VERSION	DIMENSIONS W x D x H in mm	ARTICLE NO.
DB-E 1-07	DB without ATZ*	700 x 850 x 90/ 150	65.00.06.06
DB-E 2-07	DB + 1 ATZ*	700 x 1500 x 90/ 150	65.00.06.07
DB-E 3-07	DB + 2 ATZ*	700 x 2150 x 90/ 150	65.00.06.08
DB-E 1-12	DB without ATZ*	1200 x 850 x 90/ 150	65.00.06.16
DB-E 2-12	DB + 1 ATZ*	1200 x 1500 x 90/ 150	65.00.06.17
DB-E 3-12	DB + 2 ATZ*	1200 x 2150 x 90/ 150	65.00.06.18

\*DB = disinfection basin, ATZ = drip-off zone

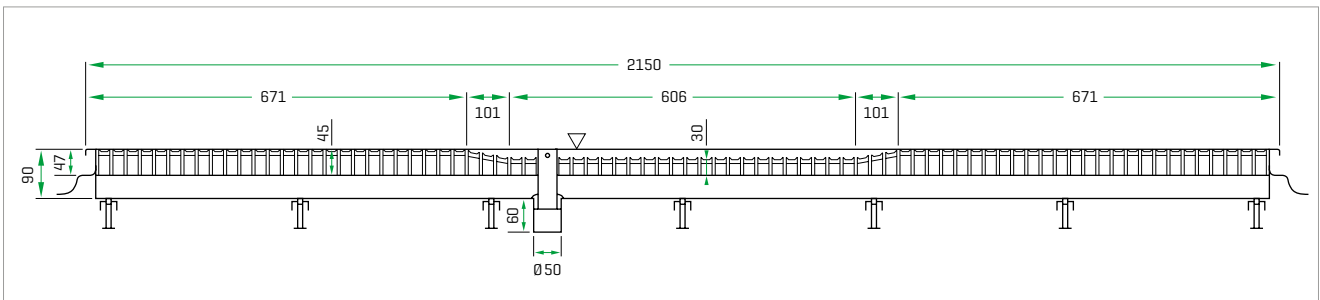

Sectional drawing, Type DB-E 3

**TYPE DOS**

# Dosing station

STAINLESS STEEL 1.4301



01

### Automatic filling and re-sharpening of disinfection basins

Dosing station consisting of:

- RITTAL-HD stainless steel switch box, wall-mounted
- SIEMENS LOGO CONTROL UNIT
- Saier dosing pump
- Leakage monitoring of the peristaltic pump
- Manual refilling [sharpening] via button from outside
- Water inlet via 3/4" AG
- Outlet via 1/4" AG
- Incl. can bracket for holding 10 kg canisters

### DESCRIPTION

In touch mode, the tank can be filled or refilled [resharpened] independently of the programming of the control unit. In automatic mode, the solenoid valve is activated via the logo control unit and the water supply starts for the pre-programmed duration. At the same time, the Saier pump is activated and the preset amount of disinfectant is added to the water.

### SPECIAL FEATURE

The parameters required for setting the Saier pump can be easily and conveniently determined via the LOGO control unit and then transferred manually.

TYPE	VERSION	DIMENSIONS	ARTICLE NO.
		W x D x H in mm	
DOS	Time-controlled	390 x 210 x 650/769	65.00.09.05



### OPTION

Can holder	see page 183
------------	--------------

**TYPE SOLE-MASTER**

# Sole Cleaning Machine

STAINLESS STEEL 1.4301



Highline, version with optional stand frame



Ecoline

- Hygienic-Design
- Adjustable dosage
- Start of the brush roll rotation by manual button
- Integrated can bracket
- wall-mounted
- Highline: Brush roll with 2 additional lateral rotary-disk brushes for optimal cleaning of the sole edges and upper leather

SOLE-MASTER	VERSION	DIMENSIONS W x D x H in mm	ARTICLE NO.
Highline	wall-mounted	715 x 410 x 1025	10.00.00.24
Ecoline	Floor model	440 x 540 x 1025	10.00.00.12

**TECHNICAL DATA**

Mains supply	230 V; 50/60 Hz
Power	0.2 kW
Water connection	3/4" - MW
Drain	1 1/2"

**OPTION**

Stand frame Highline	Article no. 49.10.01.06
----------------------	-------------------------



**TYPE BOOT-MASTER**

## Boot cleaning machine

STAINLESS STEEL 1.4301

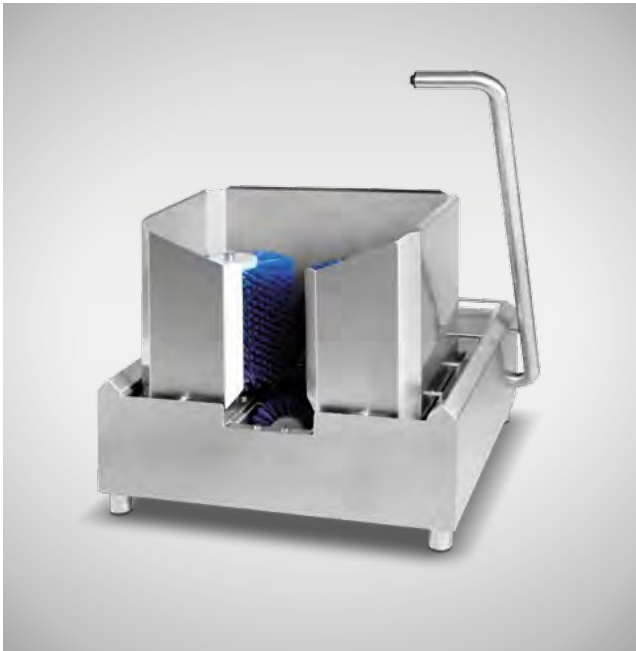

Highline



Ecoline

- Hygienic-Design
- Adjustable dosage
- Start of the brush roll rotation by manual button
- Integrated can bracket [Highline]
- Highline: 1 horizontal and 2 vertical brush rolls
- Ecoline: 1 horizontal brush roller and hand brush with water flow for manual boot shaft cleaning

BOOT-MASTER	VERSION	DIMENSIONS W x D x H in mm	ARTICLE NO.
Highline	3x 400 V	860 x 800 x 1150	10.00.10.00
Ecoline	230 V	600 x 540 x 1025	10.00.00.13

**TECHNICAL DATA**

Mains supply	230 or 400 V [see table]; 50/60 Hz
Power	Highline 0.75 kW; Ecoline 0.2 kW
Water connection	3/4" - MW
Drain	1 1/2"

**TYPE STWR**

## Boot cleaning trough

STAINLESS STEEL 1.4301



- Robust and functional design
- Stainless steel splash guard
- Water-flown hand brush
- Height-adjustable feet

TYPE	DIMENSIONS W x D x H in mm	ARTICLE NO.
STWR	1000 x 550 x 750	16.00.00.06

**TECHNICAL DATA**

Drain	1 1/2"
Water connection	3/4", max. 43 °C

**TYPE STWA**

## Sole, Boot, Apron washing walls

STAINLESS STEEL 1.4301



Type STWA-I, Article no. 16.00.00.09



Type STWA-II, Article no. 16.10.00.00  
with integrated sole cleaning system



Type STWA-III, Art. No. 16.10.00.01  
with integrated boot cleaning system

Further information can be found in the cleaning technology category on page 102.

**BOOT-STAR I**

## Pass-Through Boot Cleaning Machine

STAINLESS STEEL 1.4301



For forced-guided cleaning and disinfection of soles and boot shafts in a continuous process.

- Brush rollers removable without tool
- Adjustable dosage
- Brush roller rotation by means of hand sensor

**Boot-Star I:**

- 3 vertical bootleg cleaning brushes
- 2 horizontal brush rolls

**Boot-Star I-M:**

- Modular version to complete existing machines
- 3 vertical bootleg cleaning brushes [without sole cleaning brushes]

TYPE	SOLE BRUSHES	DIMENSIONS	ARTICLE NO.
		W x D x H in mm	
Boot-Star I	Yes	1245 x 750 x 1295	10.00.10.01
Boot-Star I-M	No	1245 x 1360 x 1295	10.00.10.04

**TECHNICAL DATA**

Mains supply	3x 400 V; 50/60 Hz
Power	Boot-Star I: 1.25 kW / Boot-Star I-M: 0.75 kW
Water connection	3/4" - MW
Drain	2"

**OPTION**

Can holder see page 183



**BOOT-STAR II**

**Pass-through boot cleaning machine**

STAINLESS STEEL 1.4301



Type Boot-Star II, maintenance cover brushes open



Type Boot-Star II, control box

For forced-guided cleaning and disinfection of soles and boot shafts in a continuous process.

- 4 horizontal, tilted leg cleaning brushes
- 2 horizontal brush rolls for sole cleaning, L: 1,100 mm
- Brush rollers removable without tool
- Adjustable dosage
- Sensor-controlled brush roller rotation in the direction of travel



Type Boot-Star II, gear motors of the brushes

TYPE	VERSION	DIMENSIONS	ARTICLE NO.
	Length of brush rollers	W x D x H in mm	
Boot-Star II	1,100 mm; 6 brushes	1100 x 1780/2380 x 1300	11.10.06.02

**TECHNICAL DATA**

Mains supply	3x 400 V; 50/60 Hz
Power	1.2 kW
Water connection	3/4" - MW
Drain	2"

**OPTION**

Can holder	see page 183
------------	--------------

01

**TYPE COMBICLEAN ECOLINE**

**Sole and boot cleaning**

STAINLESS STEEL 1.4301



Type Combiclean 2300-L

- Ecoline version for forced-guided cleaning of shoes/boots
- Robust and hygienic design
- 3 different versions or flow directions available
- Sole cleaning by means of 2 horizontally rotating brush rollers
- Boot shafts are cleaned using 3 vertically rotating brush rollers
- Touchless sensor technology or brush drive controlled via hand contact sensor (boot cleaning)
- Dual-sided railing for secure standing
- Brush rollers can be removed without tools, allowing for easy and quick cleaning
- High bristle quality with wide-area trim
- Adjustable runtime of brush rollers
- Adjustable application amount for cleaning agents

TYPE	WALK-THROUGH DIRECTION	BRUSH LENGTH in mm	DIMENSIONS W x D x H in mm	ARTICLE NO.
Combiclean 1900-R Ecoline	Right to left	700	2505 x 1285 x 1300	11.10.08.46
Combiclean 1900-L Ecoline	Left to right	700	2505 x 1285 x 1300	11.10.08.47
Combiclean 2300-R Ecoline	Right to left	1100	2905 x 1285 x 1300	11.10.08.48
Combiclean 2300-L Ecoline	Left to right	1100	2905 x 1285 x 1300	11.10.08.49
Combiclean 2700-R Ecoline	Right to left	1600	3305 x 1285 x 1300	11.10.08.50
Combiclean 2700-L Ecoline	Left to right	1600	3305 x 1285 x 1300	11.10.08.51

**TECHNICAL DATA**

Mains supply	3x 400 V; N/PE; 50/60 Hz
Power	1.25 kW
Drain	2"
Water connection	3/4" AG; mixed water max. 43 °C
Fuse protection	16 A

**OPTION**

Can holder	see page 183
------------	--------------

**TYPE COMBICLEAN HIGHLINE**

# Sole and boot cleaning

STAINLESS STEEL 1.4301

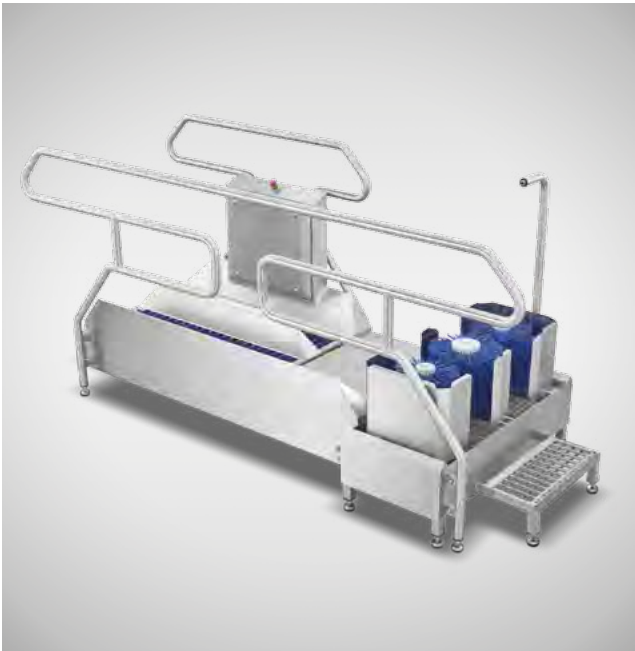

Type Combiclean 2300-R

- Soles/boot cleaning Type Combiclean Highline
- Highline version for forced-guided cleaning and disinfection of soles and boots
- Robust and hygienic design
- Hygienic-Design version
- Siemens Logo control unit, freely programmable
- Sensor-controlled brush roll rotation for both ways
- Spring cap technology for saving water, chemicals and energy costs
- Boot cleaning station for cleaning boot shafts
- Brush roller start of the boot module via hand sensor
- Railing for safe standing
- Brush rollers removable without tool
- High bristle quality with wide-area trim
- Adjustable dosage
- With lateral entry protection and splash guard

01

TYPE	WALK-THROUGH DIRECTION	BRUSH LENGTH in mm	DIMENSIONS W x D x H in mm	ARTICLE NO.
Combiclean 1900-Right	Right to left	700	2505 x 1285 x 1300	11.10.07.36
Combiclean 1900-Left	Left to right	700	2505 x 1285 x 1300	11.10.07.37
Combiclean 2300-Right	Right to left	1100	2905 x 1285 x 1300	11.10.07.38
Combiclean 2300-Left	Left to right	1100	2905 x 1285 x 1300	11.10.07.39
Combiclean 2700-Right	Right to left	1600	3305 x 1285 x 1300	11.10.07.40
Combiclean 2700-Left	Left to right	1600	3305 x 1285 x 1300	11.10.07.41

**TECHNICAL DATA**

Mains supply	3x 400 V; N/PE; 50/60 Hz
Power	1.25 kW
Drain	2" (DN 50)
Water connection	3/4" AG; mixed water max. 43 °C
Fuse protection	16 A

**OPTION**

Can holder	see page 183
------------	--------------

**SOLE-STAR ECOLINE**

**Pass-Through Sole Cleaning Machine 1-lane**

STAINLESS STEEL 1.4301



Sole-Star Ecoline 800-Right

**WALK-THROUGH DIRECTIONS**

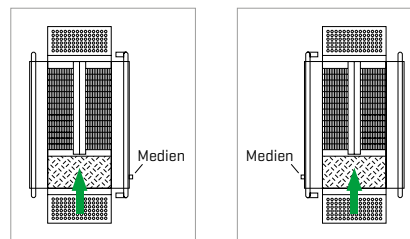

Right-hand version

Left-hand version

TYPE	BRUSH LENGTH	DIMENSIONS W x D x H in mm	ARTICLE NO.
800-Right	400 mm	1410 x 860 x 1300	11.10.08.38
1100-Right	700 mm	1710 x 860 x 1300	11.10.08.40
1500-Right	1,100 mm	2110 x 860 x 1300	11.10.08.42
2000-Right	1,600 mm	2610 x 860 x 1300	11.10.08.44
800-Left	400 mm	1410 x 860 x 1300	11.10.08.39
1100-Left	700 mm	1710 x 860 x 1300	11.10.08.41
1500-Left	1,100 mm	2110 x 860 x 1300	11.10.08.43
2000-Left	1,600 mm	2610 x 860 x 1300	11.10.08.45

For forced-guided, walk-through cleaning and disinfection of the soles.

- With board control
- Sensor-controlled brush roll rotation for both ways
- Brush rollers removable without tool
- Adjustable dosage
- Also as dry version available (for ex. bakery industry)

**OPTIONS**

Lateral entry	on request
Boot cleaning module, Boot-Star I-M with bypass for persons wearing clogs (Combiclean), see page 50	Article no. 10.00.10.04
Can container in closed version	on request
Canister holder, container	see page 183

**TECHNICAL DATA**

Mains supply	3x 400 V; 50/60 Hz; 16 A
Power	0.5 kW
Water connection	3/4" - MW
Drain	2"

**SOLE-STAR HIGHLINE**

**Pass-Through Sole Cleaning Machine 1-lane**

STAINLESS STEEL 1.4301



Sole-Star Highline 800-Right

**WALK-THROUGH DIRECTIONS**

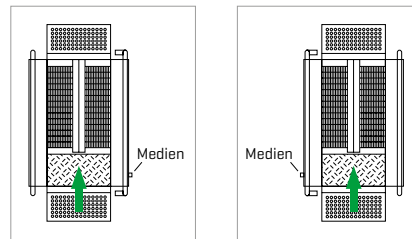

Right-hand version

Left-hand version

TYPE	BRUSH LENGTH	DIMENSIONS W x D x H in mm	ARTICLE NO.
800-Right	400 mm	1410 x 860 x 1300	11.10.07.28
1100-Right	700 mm	1710 x 860 x 1300	11.10.07.30
1500-Right	1,100 mm	2110 x 860 x 1300	11.10.07.32
2000-Right	1,600 mm	2610 x 860 x 1300	11.10.07.34
800-Left	400 mm	1410 x 860 x 1300	11.10.07.29
1100-Left	700 mm	1710 x 860 x 1300	11.10.07.31
1500-Left	1,100 mm	2110 x 860 x 1300	11.10.07.33
2000-Left	1,600 mm	2610 x 860 x 1300	11.10.07.35

For forced-guided, walk-through cleaning and disinfection of the soles.

- With Siemens Logo control unit
- Sensor-controlled brush roller rotation for outward and return via spring cup technology to save water, chemicals and energy costs
- Brush rollers removable without tool
- Adjustable dosage
- Also as dry version available (for ex. bakery industry)
- With lateral entry protection and splash guard

**OPTIONS**

Lateral entry	on request
Boot cleaning module, Boot-Star I-M with bypass for persons wearing clogs [Combiclean], see page 50	Article no. 10.00.10.04
Can container in closed version	on request
Canister holder, container	see page 183

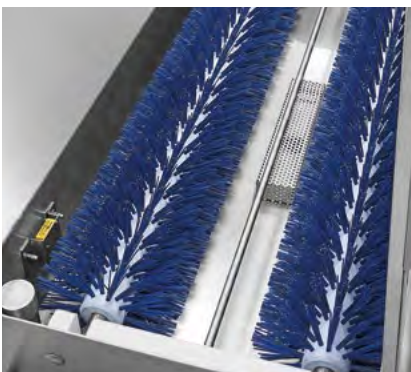

Energy-saving spring pot technology

**TECHNICAL DATA**

Mains supply	3x 400 V; 50/60 Hz; 16 A
Power	0.5 kW
Water connection	3/4" - MW
Drain	2"

**CLEAN-CHECK ECOLINE**

# Hygiene station 1-lane

STAINLESS STEEL 1.4301



Clean-Check Ecoline 1100-Right

### WALK-THROUGH DIRECTIONS

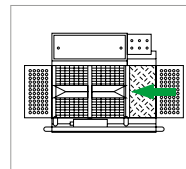

Right-hand version

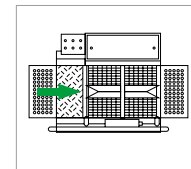

Left-hand version

TYPE	BRUSH LENGTH	DIMENSIONS W x D x H in mm	ARTICLE NO.
800-Right	400 mm	1410 x 975 x 1785	11.10.08.52
1100-Right	700 mm	1710 x 975 x 1785	11.10.08.54
1500-Right	1,100 mm	2110 x 975 x 1785	11.10.08.56
2000-Right	1,600 mm	2610 x 975 x 1785	11.10.08.58
800-Left	400 mm	1410 x 975 x 1785	11.10.08.53
1100-Left	700 mm	1710 x 975 x 1785	11.10.08.55
1500-Left	1,100 mm	2110 x 975 x 1785	11.10.08.57
2000-Left	1,600 mm	2610 x 975 x 1785	11.10.08.59

### OPTIONS

Lateral entry or exit	on request
Document tray, Type DA-III (Wall-mounted by means of 2 holes. With optional brackets also suitable for mounting on railings or cover housing)	Article no. 18.00.03.94
2-hand soaping instead of hand disinfection	Article no. 10.00.00.92
Optical empty-can message by multi-LED (Ecoline)	Article no. 99.87.00.34
Disinfection bath + drip-off zone, instead of brush rollers (Desi-Check)	on request
Can bracket in closed, lockable version	on request
Canister holder, container	see page 183

1-lane, forced-guided disinfection of the soles & hands

### PERSON SEPARATION

Approval after terminated medium application only!

- With stable turnstile [2 years warranty\*] incl. board control, potential-free contact available
- 2-hand disinfection unit including tamper-proof sensor technology
- Return path electrically enabled or permanently blocked
- Dosage of the application quantity adjustable
- Also as dry version available [for ex. bakery industry]

\*for the turnstile mechanism!

### TECHNICAL DATA

Mains supply	3x 400 V; 50/60 Hz
Power	0.6 kW
Water connection	3/4" - MW
Drain	2"



**CLEAN-CHECK HIGHLINE**

# Hygiene station 1-lane

STAINLESS STEEL 1.4301



Clean-Check Highline 1100-Left

**WALK-THROUGH DIRECTIONS**

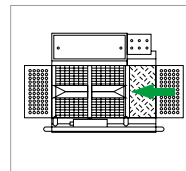

Right-hand version

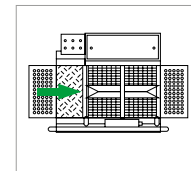

Left-hand version

TYPE	BRUSH LENGTH	DIMENSIONS W x D x H in mm	ARTICLE NO.
800-Right	400 mm	1410 x 1060 x 1785	11.10.07.42
1100-Right	700 mm	1710 x 1060 x 1785	11.10.07.44
1500-Right	1,100 mm	2110 x 1060 x 1785	11.10.07.46
2000-Right	1,600 mm	2610 x 1060 x 1785	11.10.07.48
800-Left	400 mm	1410 x 1060 x 1785	11.10.07.43
1100-Left	700 mm	1710 x 1060 x 1785	11.10.07.45
1500-Left	1,100 mm	2110 x 1060 x 1785	11.10.07.47
2000-Left	1,600 mm	2610 x 1060 x 1785	11.10.07.49

**OPTIONS**

Lateral entry or exit	on request
Document tray, Type DA-III [Wall-mounted by means of 2 holes. With optional brackets also suitable for mounting on railings or cover housing]	Article no. 18.00.03.94
2-hand soaping instead of hand disinfection	Article no. 10.00.00.92
Disinfection bath + drip-off zone, instead of brush rollers [Desi-Check]	on request
Can bracket in closed, lockable version	on request
Canister holder, container	see page 183

1-lane, forced-guided disinfection of the soles & hands

**PERSON SEPARATION**

Approval after terminated medium application only!

- With vandal-proof turnstile [10-year guarantee\*]  
Including freely programmable Siemens Logo control unit
- 2-hand disinfection unit including tamper-proof sensor technology
- Return path electrically enabled or permanently blocked
- Dosage of the application quantity adjustable
- Optical empty-can message by multi-LED [Highline]
- Also as dry version available [for ex. bakery industry]
- Spring cap technology for saving water, chemicals and energy costs

*\*for the turnstile mechanism!*

**TECHNICAL DATA**

Mains supply	3x 400 V; 50/60 Hz
Power	0.6 kW
Water connection	3/4" - MW
Drain	2"

**COMBICLEAN-CONTROL ECOLINE**

**Hygiene station 1-lane**

STAINLESS STEEL 1.4301



Combiclean-Control Ecoline, 1900-Left

**WALK-THROUGH DIRECTIONS**

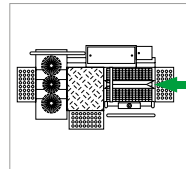

Right-hand version

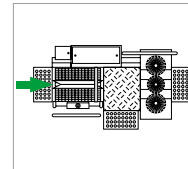

Left-hand version

TYPE	BRUSH LENGTH	DIMENSIONS W x D x H in mm	ARTICLE NO.
1900-Right	700 mm	2505 x 1285 x 1800	11.10.08.62
2300-Right	1,100 mm	2905 x 1285 x 1800	11.10.08.64
1900-Left	700 mm	2505 x 1285 x 1800	11.10.08.63
2300-Left	1,100 mm	2905 x 1285 x 1800	11.10.08.65

**TECHNICAL DATA**

Mains supply	3x 400 V; 50/60 Hz
Power	1.5 kW
Water connection	3/4" - MW
Drain	2"

1-lane, forced-guided disinfection of the soles, boots & hands

**PERSON SEPARATION**

Approval after terminated medium application only!

- With stable turnstile [2 years warranty\*]  
incl. circuit board control, potential-free contact available
- 2-hand disinfection unit including tamper-proof sensor technology
- 3 vertical bootleg cleaning brushes, start via hand sensor
- Return path electrically enabled or permanently blocked
- Dosage of the application quantity adjustable

*\*for the turnstile mechanism!*

**OPTIONS**

Lateral entry	on request
Document tray, Type DA-III [Wall-mounted by means of 2 holes. With optional brackets also suitable for mounting on railings or cover housing]	Article no. 18.00.03.94
Can bracket in closed, lockable version	see page 183
Can container in closed version	see page 183



**COMBICLEAN-CONTROL HIGHLINE**

**Hygiene station 1-lane**

STAINLESS STEEL 1.4301

01



Combiclean-Control Highline, 1500-Right

**WALK-THROUGH DIRECTIONS**

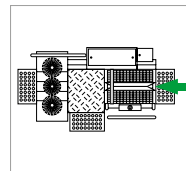

Right-hand version

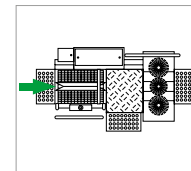

Left-hand version

TYPE	BRUSH LENGTH	DIMENSIONS W x D x H in mm	ARTICLE NO.
1900-Right	700 mm	2505 x 1350 x 1800	11.10.07.52
2300-Right	1,100 mm	2905 x 1350 x 1800	11.10.07.54
2700-Right	1,600 mm	3305 x 1350 x 1800	11.10.07.56
1900-Left	700 mm	2505 x 1350 x 1800	11.10.07.53
2300-Left	1,100 mm	2905 x 1350 x 1800	11.10.07.55
2700-Left	1,600 mm	3305 x 1350 x 1800	11.10.07.57

**TECHNICAL DATA**

Mains supply	3x 400 V; 50/60 Hz
Power	1.5 kW
Water connection	3/4" - MW
Drain	2"



Energy-saving spring pot technology

1-lane, forced-guided disinfection of the soles, boots & hands

**PERSON SEPARATION**

Approval after terminated medium application only!

- With vandal-proof turnstile [10-year guarantee\*]  
Including freely programmable Siemens Logo control unit
- 2-hand disinfection unit including tamper-proof sensor technology
- 3 vertical bootleg cleaning brushes, start via hand sensor
- Return path electrically enabled or permanently blocked
- Dosage of the application quantity adjustable
- Optical empty-can message by multi-LED [Highline]
- Spring cap technology for saving water, chemicals and energy costs

*\*for the turnstile mechanism!*

**OPTIONS**

Lateral entry	on request
Document tray, Type DA-III (Wall-mounted by means of 2 holes. With optional brackets also suitable for mounting on railings or cover housing)	Article no. 18.00.03.94
Can bracket in closed, lockable version	see page 183
Can container in closed version	see page 183

**CLEAN-CHECK DUO HIGHLINE / ECOLINE**

**Hygiene station 2-lane**

STAINLESS STEEL 1.4301



Clean-Check DUO Ecoline 1500



Clean-Check DUO Highline 1500

2-lane, forced-guided disinfection of the soles & hands  
 Person separation: Approval after terminated medium application only!

- Highline version with vandalism-proof turnstiles (10 years warranty\*) including freely programmable Siemens Logo control unit
- Ecoline version with stable turnstiles (2 years warranty\*) incl. circuit board control, potential-free contact available
- Each lane separately controlled!
- 2-hand disinfection unit including tamper-proof sensor technology
- Return path electrically enabled or permanently blocked
- Ecoline: Sensor-controlled brush roller rotation
- Highline: Spring cup technology
- Dosage of the application quantity adjustable
- Optical empty-can message by multi-LED (Highline)

\*for the turnstile mechanism!



HIGHLINE TYPE	BRUSH LENGTH	DIMENSIONS W x D x H in mm	ARTICLE NO.
1500	1,100 mm	1890 x 2110 x 1850	11.10.07.50
2000	1,600 mm	1890 x 2610 x 1850	11.10.07.51

ECOLINE TYPE	BRUSH LENGTH	DIMENSIONS W x D x H in mm	ARTICLE NO.
1500	1,100 mm	1710 x 2110 x 1850	11.10.08.60
2000	1,600 mm	1710 x 2610 x 1850	11.10.08.61

**TECHNICAL DATA**

Mains supply	3x 400 V; 50/60 Hz
Power	1.6 kW
Water connection	3/4" - MW
Drain	2x 2"

**OPTIONS**

Document tray, Type DA-III (Wall-mounted by means of 2 holes. With optional brackets also suitable for mounting on railings or cover housing)	Article no. 18.00.03.94
1-lane entry only / 1-lane exit only	Article no. 10.00.32.30
Disinfection bath + drip-off zone, instead of brush rollers (Duo-Desi-Check)	on request
Can bracket in closed, lockable version	see page 183
Boot cleaning module, Boot Star I-module with bypass for persons wearing clogs	on request

**CONTROL-STAR HIGHLINE / ECOLINE**

**Hygiene station 2-lane**

STAINLESS STEEL 1.4301



Control-Star Ecoline 1500-D/B



Control-Star Highline 2000-B/B

2-lane, forced-guided disinfection of the soles and hands at highly frequented production entries. Separate entry and exit lanes! Person separation: Approval after terminated medium application only!

- Highline version with vandalism-proof turnstile [10 years warranty\*] including freely programmable Siemens Logo control unit
- Ecoline version with stable turnstile [2 years warranty\*] incl. circuit board control, potential-free contact available
- At the entry side, with brush roll module instead of walk-through disinfection basin and drip-off zone, see variants
- Brush roller length 1,600 mm [Highline] or 1,100 mm [Ecoline]
- 2-hand disinfection unit including tamper-proof sensor technology
- Dosage of the application quantity adjustable
- Ecoline: Sensor-controlled brush roller rotation
- Highline: Spring cup technology
- Disinfection basin with time-controlled detergent supply
- Optical empty-can message by multi-LED [Highline]

\*for the turnstile mechanism!



Brush rollers both sides

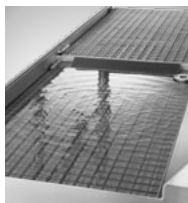

Disinfection bath



Knife basket chute

HIGHLINE TYPE	ENTRANCE / EXIT	DIMENSIONS W x D x H in mm	ARTICLE NO.
2000-D/B	Disinfection + ATZ / Brushes	1710 x 2610 x 1680	11.10.07.58
2000-B/B	Brushes / Brushes	1710 x 2610 x 1680	11.10.07.59
2000-D/B	Disinfection + ATZ / Brushes	1500 x 2610 x 1680	11.10.07.60
2000-B/B	Brushes / Brushes	1500 x 2610 x 1680	11.10.07.61

ECOLINE TYPE	ENTRANCE / EXIT	DIMENSIONS W x D x H in mm	ARTICLE NO.
1500-D/B	Disinfection + ATZ / Brushes	1710 x 2110 x 1785	11.10.08.68
1500-B/B	Brushes / Brushes	1710 x 2110 x 1785	11.10.08.69

**TECHNICAL DATA**

Mains supply	3x 400 V; 50/60 Hz
Power	1.25 - 1.5 kW
Water connection	3/4" - MW
Drain	2x 2"

**OPTIONS**

Knife basket chute for entry lane	Article no. 99.80.01.41
Document tray, Type DA-III (Wall-mounted by means of 2 holes. With optional brackets: Attachment to the railing or cover housing)	Article no. 18.00.03.94
Can bracket in closed, lockable version	see page 183
Handrails and gates	on request
Boot cleaning module, Boot Star I-module with bypass for persons wearing clogs	on request

**CHECK-IN-STATION II ECOLINE**

# Hygiene station 1-lane



Ecoline II check-in station, 1100-Left





Detail: Outlet tap and soap dispenser



Option: Lateral entry



Application photo at stairway exit [on request]

Compact 1-lane complete hygiene solution for forced guided cleaning and disinfection of soles & hands in a continuous process

**PERSON SEPARATION**

Approval after terminated medium application only!

- Ecoline version with stable turnstile [2 years warranty\*]
- incl. circuit board control, potential-free contact available
- Versions with left-hand or right-hand passage direction available
- Sensor-operated hand basin with integrated soap dispenser
- Contactless fittings for water and soap
- Folded papertowel dispenser and wire mesh waste paper basket [40 litres]
- 2-hand disinfection unit including tamper-proof sensor technology
- Return path blocked or electrically enabled
- Sensor-controlled brush roll rotation for both ways
- Dosage of the application quantity adjustable
- Also as dry version available [for ex. bakery industry]

\*for the turnstile mechanism!

**TECHNICAL DATA**

Mains supply	3x 400 V; 50/60 Hz
Power	0.6 kW
Water connection	3/4" - MW
Drain	2"

TYPE	BRUSH LENGTH	DIMENSIONS W x D x H in mm	ARTICLE NO.
800-Right	400 mm	1410 x 975 x 1785	11.10.08.70
1100-Right	700 mm	1710 x 975 x 1785	11.10.08.72
1500-Right	1,100 mm	2110 x 975 x 1785	11.10.08.74
2000-Right	1,600 mm	2610 x 975 x 1785	11.10.08.76
800-Left	400 mm	1410 x 975 x 1785	11.10.08.71
1100-Left	700 mm	1710 x 975 x 1785	11.10.08.73
1500-Left	1,100 mm	2110 x 975 x 1785	11.10.08.75
2000-Left	1,600 mm	2610 x 975 x 1785	11.10.08.77

**OPTIONS**

Document tray, Type DA-III (Wall-mounted by means of 2 holes. With optional brackets also suitable for mounting on railings or cover housing)	Article no. 18.00.03.94
Optical empty-can message by multi-LED [Ecoline]	Article no. 99.87.00.34
Lateral entry	on request
Disinfection bath + drip-off zone, instead of brush rollers	on request
Closed can holder	see page 183
Stainless steel roll box RB-E-0 instead of towel dispenser	on request
Waste paper baskets of 60 litres made of wire mesh [PK-D] or stainless steel sheet [PK-E]	on request

**WALK-THROUGH DIRECTIONS**

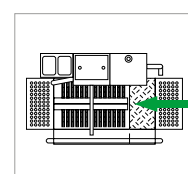

Right-hand version

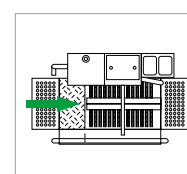

Left-hand version

CHECK-IN-STATION | HIGHLINE

# Hygiene station 1-lane



Check-In-Station | 1200-R Highline



Check-In-Station I 1200-L Highline

VERSION	BRUSH LENGTH in mm	DIMENSIONS W x D x H in mm	ARTICLE NO.
1200 Right	700	1800 x 1050 x 1800	11.10.07.26
1200 links	700	1800 x 1050 x 1800	11.10.07.27

**TECHNICAL DATA**

Mains supply	3x 400 V; N/PE; 50/60 Hz
Power	0.8 kW
Fuse protection	16 A
Water connection	3/4" AG*
Water drain	2" [DN 50]

The Check-In-Station I is used for the forced-guided cleaning and disinfection of shoe soles and hands in a continuous process. The turnstile will only be unlocked for a person after the complete sequence of cleaning steps has been completed. The return path is automatically released by means of an inductive sensor [underneath the step grate].

Optionally and at no extra charge, the return path release can be activated via a client-side time recording system or permanently locked.

- Robust MOHN construction in hygienic design
- Control: SIEMENS LOGO control unit generation 8, all times individually adjustable
- Hygienic hand wash basin with automatic 1-hand soap dispenser
- Towel Dispenser and paper basket [40 l]
- 2-Hand Disinfection unit [Tamper-proof]
- Vandal-proof turnstile\*
- Encapsulated IP68 sensor for end position detection of the turnstile
- Multi-LED signal indicator [RED-YELLOW-GREEN]
- Brushes can be removed WITHOUT tools  
ADVANTAGE: easy and quick cleaning of the machine
- Cleaning start/stop via person detection on brush rollers  
ADVANTAGE: Energy, water, and chemical savings compared to conventional sensor control
- With railing for secure walkover
- Adjustable application quantities
- Motorised plate: 380 mm
- Including canister holder [loosely enclosed] for machine mounting or wall mounting

\*10 years guarantee for the turnstile mechanism!

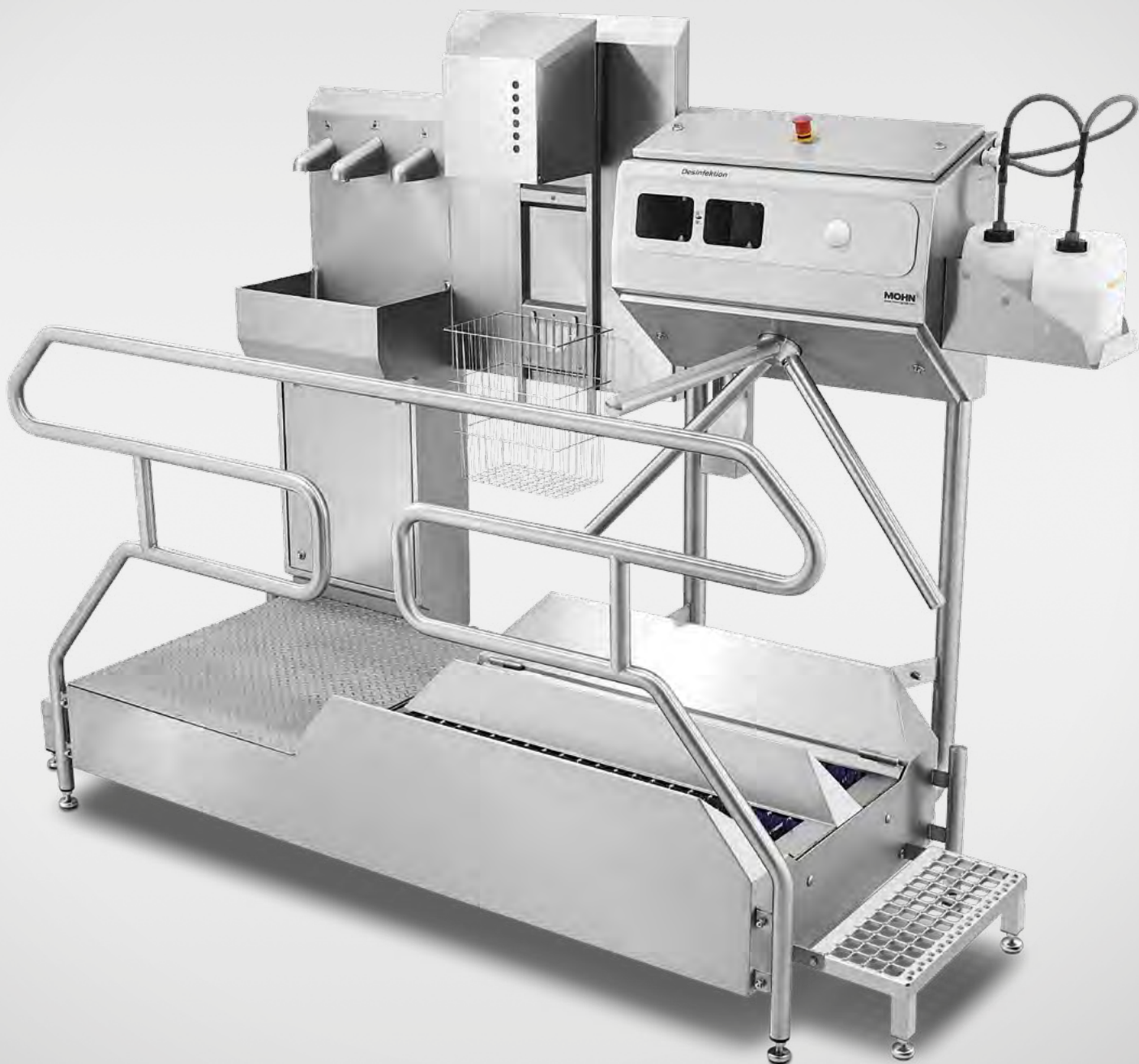

Check-In-Station II Highline left-hand



**CHECK-IN-STATION II HIGHLINE**

# Hygiene station 1-lane

STAINLESS STEEL 1.4301



Hand basin incl. soap dispenser



Option: Boot cleaning station



Disinfection basin with drip-off zone (on request)

Compact 1-lane hygiene complete solution for forced-guided cleaning and disinfection of soles and hands in a continuous process.

**PERSON SEPARATION**

Approval after terminated medium application only!

- With vandal-proof turnstile [10-year guarantee\*] including freely programmable Siemens Logo control unit
- Versions with left-hand or right-hand passage direction available
- Sensor-operated hand basin with integrated 2-hand soap dispenser
- Folded papertowel dispenser and wire mesh waste paper basket [40 litres]
- 2-hand disinfection unit including tamper-proof sensor technology
- Return path electrically enabled or permanently blocked
- Dosage of the application quantity adjustable
- Optical empty-can message by multi-LED
- Also as dry version available [for ex. bakery industry]
- Spring cap technology for saving water, chemicals and energy costs
- The return path is automatically released by means of an inductive sensor [underneath the step grate]. Optionally and at no extra charge, the return path release can be activated via a client-side time recording system or permanently locked.

\*for the turnstile mechanism!

VERSION	BRUSH LENGTH in mm	DIMENSIONS W x D x H in mm	ARTICLE NO.
Right-hand	1100	2400 x 1060 x 1995	11.10.07.69
Left-hand	1100	2400 x 1060 x 1995	11.10.07.70
Right-hand	700	1800 x 1050 x 1800	11.10.07.26
Left-hand	700	1800 x 1050 x 1800	11.10.07.27

**TECHNICAL DATA**

Mains supply	3x 400 V; 50/60 Hz
Power	0.6 kW
Water connection	3/4" - MW
Drain	2"

**OPTIONS**

Lateral entry	on request
Document tray, Type DA-III [Wall-mounted by means of 2 holes. With optional brackets also suitable for mounting on railings or cover housing]	Article no. 18.00.03.94
Disinfection bath + drip-off zone, instead of brush rollers	on request
Closed can holder	see page 183
Boot cleaning module, Boot Star I-module with bypass for persons wearing clogs	on request
Stainless steel roll box RB-E-0 instead of towel dispenser	on request
Paper baskets [60 l] made of wire mesh [PK-D] or stainless steel sheet [PK-E]	on request

**WALK-THROUGH DIRECTIONS**

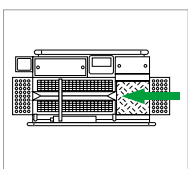

Right-hand version

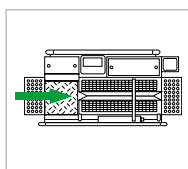

Left-hand version

**CHECK-IN-STATION III ECOLINE**

# Hygiene station 1-lane



Check-In-Station III Ecoline, 1500-Left



Option: Lateral entry



Option: Boot cleaning station



Outlet tap + soap dispenser

Compact 1-lane hygiene complete solution for forced-guided cleaning and disinfection of soles and hands in a continuous process. High-speed hand drying: Within 10 seconds!

**PERSON SEPARATION**

Approval after terminated medium application only!

- Ecoline version with stable turnstile [2 years warranty\*]
- incl. circuit board control, potential-free contact available
- Versions with left-hand or right-hand passage direction available
- Sensor-operated hand basin with integrated soap dispenser
- Contactless fittings for water and soap
- High-speed hand drier, 3.2 kW
- 2-hand disinfection unit including tamper-proof sensor technology
- Return path optionally blocked or electrically released
- Sensor-controlled brush roll rotation for both ways
- Dosage of the application quantity adjustable
- Potential-free contact available, for ex. for time-recording system
- Multi-LED signal display
- Also as dry version available [for ex. bakery industry]

\*for the turnstile mechanism!



TYPE	BRUSH LENGTH	DIMENSIONS W x D x H in mm	ARTICLE NO.
1500-Right	700 mm	2110 x 975 x 2010	11.10.08.78
1500-Left	700 mm	2110 x 975 x 2010	11.10.08.79

**TECHNICAL DATA**

Mains supply	3x 400 V; 50/60 Hz
Power	4.2 kW
Water connection	3/4" - MW
Drain	2"

**OPTIONS**

Document tray, Type DA-III (Wall-mounted by means of 2 holes. With optional brackets also suitable for mounting on railings or cover housing)	Article no. 18.00.03.94
Optical empty-can message by multi-LED (Ecoline)	Article no. 99.87.00.34
Lateral entry	on request
Disinfection bath + drip-off zone, instead of brush rollers	on request
Closed can holder	see page 183
Boot cleaning module, Boot Star I-module with bypass for persons wearing clogs	on request

**WALK-THROUGH DIRECTIONS**

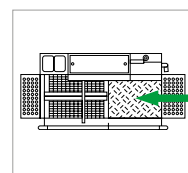

Right-hand version

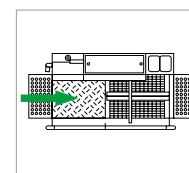

Left-hand version



Check-In-Station III Highline, right



**CHECK-IN-STATION III HIGHLINE**

**Hygiene station 1-lane**

STAINLESS STEEL 1.4301

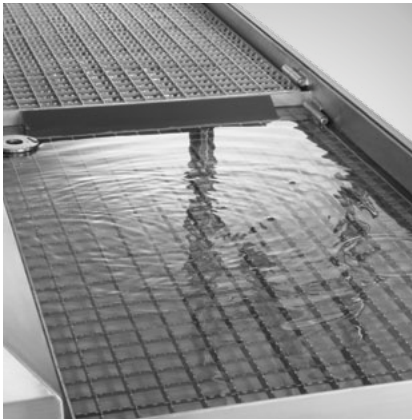

Option: Disinfection bath



Option: Boot cleaning station



High-speed hand drier "Jet"

Compact 1-lane hygiene complete solution for forced-guided cleaning and disinfection of soles and hands in a continuous process. High-speed hand drying: Within 10 seconds!

**PERSON SEPARATION**

Approval after terminated medium application only!

- Highline version with vandalism-proof turnstile [10 years warranty\*] including freely programmable Siemens Logo control unit
- Versions with left-hand or right-hand passage direction available
- Sensor-operated hand basin with integrated 2-hand soap dispenser
- High-speed hand drier Type Jet-II, 3.2 kW
- 2-hand disinfection unit including tamper-proof sensor technology
- The return path is automatically released by means of an inductive sensor [underneath the step grate]. Optionally and at no extra charge, the return path release can be activated via a client-side time recording system or permanently locked.
- Dosage of the application quantity adjustable
- Optical empty-can message by multi-LED
- Also as dry version available [for ex. bakery industry]
- Spring cap technology for saving water, chemicals and energy costs

\*for the turnstile mechanism!

VERSION	BRUSH LENGTH	DIMENSIONS W x D x H in mm	ARTICLE NO.
Right-hand	1,100 mm	2400 x 1060 x 1995	11.10.07.71
Left-hand	1,100 mm	2400 x 1060 x 1995	11.10.07.72

**TECHNICAL DATA**

Mains supply	3x 400 V; 50/60 Hz
Power	4.2 kW
Water connection	3/4" - MW
Drain	2"

**OPTIONS**

Document tray, Type DA-III (Wall-mounted by means of 2 holes. With optional brackets also suitable for mounting on railings or cover housing)	Article no. 18.00.03.94
Lateral entry	on request
Disinfection bath + drip-off zone, instead of brush rollers	on request
Closed can holder	see page 183
Boot cleaning module, Boot Star I-module with bypass for persons wearing clogs	on request

**WALK-THROUGH DIRECTIONS**

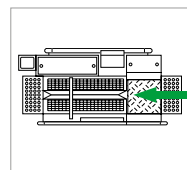

Right-hand version

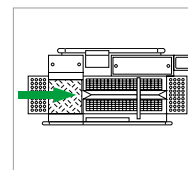

Left-hand version

**TYPE DK-E HIGHLINE**

# Turnstile

STAINLESS STEEL 1.4301



DK-E Highline, stand-alone model

- Highline version with vandalism-proof turnstile [10 years warranty\*]
- Electrically released for passage, electrically locked on the return path
- Siemens Logo control unit, all times individually adjustable
- Encapsulated IP68 sensor for end position detection of the turnstile

*\*for the turnstile mechanism!*

TYPE	VERSION	DIMENSIONS W x D x H in mm	ARTICLE NO.
DK-E WR	Wall, right	800 x 345/ 935 x 600	11.10.07.15
DK-E WL	Wall, left	800 x 345/ 935 x 600	11.10.07.16
DK-E SR	Floor-mounted, right	800 x 345/ 935 x 1410	11.10.07.17
DK-E SL	Floor-mounted, left	800 x 345/ 935 x 1410	11.10.07.18

**TECHNICAL DATA**

Mains supply	230 V; 50/60 Hz
Power	0.1 kW
Voltage	24 V/DC

**TYPE DK-E ECOLINE**

# Turnstile

STAINLESS STEEL 1.4301



DK-E Ecoline, wall-mounted version

- Ecoline version with stable turnstile [2 years warranty\*]
- Return path optionally blocked or electrically released
- Potential-free contact available, for ex. for time-recording system
- Chicane and handrail

*\*for the turnstile mechanism!*

TYPE	VERSION	DIMENSIONS W x D x H in mm	ARTICLE NO.
DK-E WR	Wall, right	400 x 345/ 895 x 575	11.10.08.17
DK-E WL	Wall, left	400 x 345/ 895 x 575	11.10.08.18
DK-E SR	Floor-mounted, right	400 x 345/ 895 x 1385	11.10.08.19
DK-E SL	Floor-mounted, left	400 x 345/ 895 x 1385	11.10.08.20

**TECHNICAL DATA**

Mains supply	230 V; 50/60 Hz
Power	0.1 kW
Voltage	24 V/DC

**TYPE PDK**

## Portal turnstile 1-lane

STAINLESS STEEL 1.4301



Sophisticated portal turnstile for person separation and access control.

- Turnstile column with 120° angular steps
- Hygienic-Design
- Suited for wet and outdoor areas
- Vandalism-proof turnstile system
- Freely rotatable in case of power failure [Type PDK-E]
- L Potential-free contact available, for ex. for time-recording system [Type DK-E]

TYPE	VERSION	DIMENSIONS W x D x H in mm	ARTICLE NO.
PDK-M	Mechanical	1600 x 1260 x 2365	99.80.92.22
PDK-E-1/1-lane	Electric 1-sided	1600 x 1260 x 2365	99.80.82.22
PDK-E-2/1-lane	Electric 2-sided	1600 x 1260 x 2365	99.80.82.23

**TECHNICAL DATA**

Mains supply	230 V; 50/60 Hz
Temperature range	-25 °C to +40 °C

**TYPE PDK**

## Portal turnstile 2-lane

STAINLESS STEEL 1.4301



High-quality 2-lane portal turnstile for person separation and access control.

- Completely made of stainless steel, surface brushed
- Version for floor mounting
- Passage electrically actuated on one side
- Turnstile column with 120° angular steps
- Suited for wet and outdoor areas
- Pitched roof version in Hygienic-Design
- Vandalism-proof turnstile system
- Freely rotatable in case of panic or power failure
- Interface for card readers, for example: potential-free contacts
- Passage height: approx. 2,100 mm

TYPE	VERSION	DIMENSIONS W x D x H in mm	ARTICLE NO.
PDK-E-1/2-lane	Electric 1-sided	2380 x 1600 x 2365	99.80.82.26
PDK-E-2/2-lane	Electric 2-sided	2380 x 1600 x 2365	99.80.82.25

**TECHNICAL DATA**

Mains supply	230 V; 50/60 Hz
Power	0.2 kW
Operating temperature	-25 °C to +40 °C
Weight	200 kg

PDK-E-2/2-lane



**TYPE DS-DA**

# Drop-arm turning lock

STAINLESS STEEL 1.4301



Drop-arm turning lock, DK

- High-quality drop-arm turning lock
- Electric version
- Optionally available for Soap or Desi-Control, as well as turnstile DK-Highline
- In case of fire or panic, the drop-arm falls down and releases the passage
- Potential-free contact for coupling with, for ex. fire alarm system
- Incl. key switch for authorised release, e.g. for cleaning

TYPE	VERSION	DIMENSIONS	ARTICLE NO.
		W x D x H in mm	
Soap SR-D	Floor-mounted, right	853 x 445/ 960 x 1420	11.10.07.06
Soap SL-D	Floor-mounted, left	853 x 445/ 960 x 1420	11.10.07.07
Desi SR-D	Floor-mounted, right	853 x 445/ 960 x 1420	11.10.07.13
Desi SL-D	Floor-mounted, left	853 x 445/ 960 x 1420	11.10.07.14
DK SR-D	Floor-mounted, right	400 x 300/ 815 x 1040	11.10.07.20
DK SL-D	Floor-mounted, left	400 x 300/ 815 x 1040	11.10.07.21

## Optimum and narrowest escape routes!

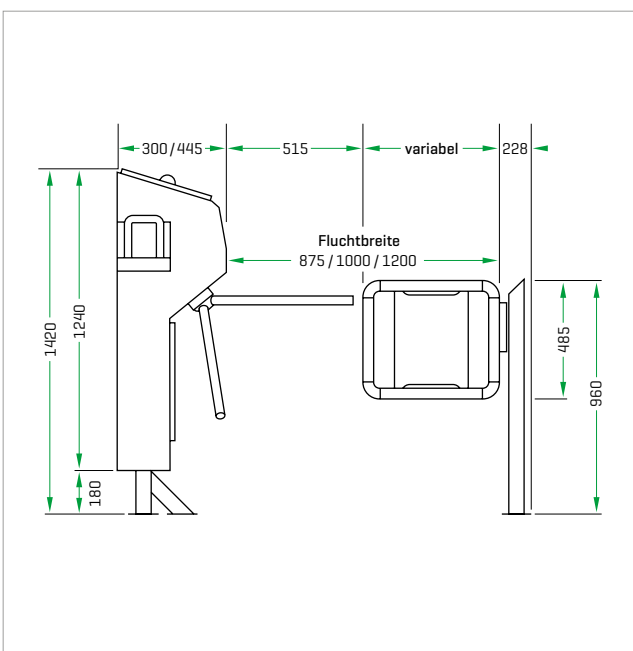

By connecting the drop-arm turn-lock with the magnetic swing gate, escape routes from 875 mm to 1,200 mm can be realised, even in narrow hygiene aisles, in accordance with the workplace directive [ASR-A 2.3]!

**TYPE MFT**

# Magnetic wing gate

STAINLESS STEEL 1.4301

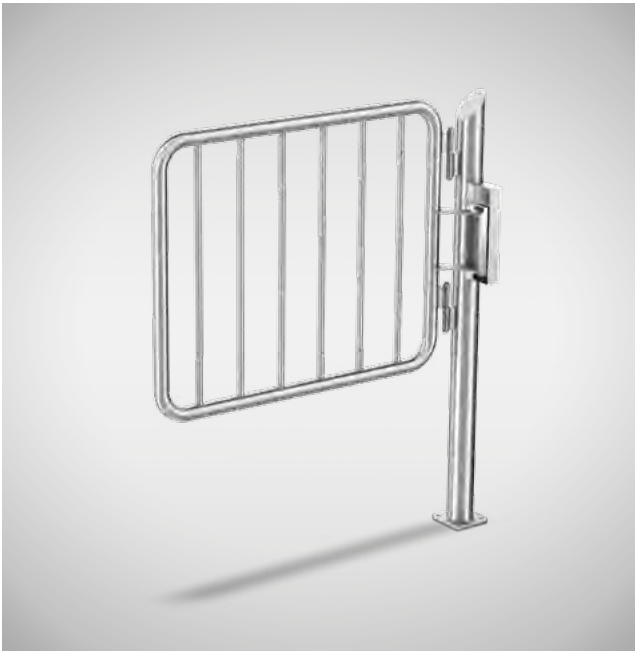

- Magnetic Swing Gate consists of the corresponding magnetic swing gate and the surface mount magnet complete set [Article no. 39.00.05.06]
- 6 different standard widths
- Versions: Stand and wall with stop on the right or left respectively
- Electromagnetic surface holding magnet<sup>1</sup>
- Integrated Hall sensors detect whether the door is open or closed<sup>1</sup>
- Encapsulated connection cable, IP67<sup>1</sup>
- Siemens Logo control unit with 4 inputs and 2 outputs, freely programmable, installed in Rittal compact enclosure HD<sup>1</sup>
- Incl. key switch for authorised opening<sup>1</sup>
- Incl. house alarm box for emergency opening<sup>1</sup>
- Incl. acoustic signal (horn) when opened via house alarm box<sup>1</sup>
- 2 connections to on-site systems available<sup>1</sup> [e.g. card reader or fire alarm system]

NUMBER OF PERSONS according to ASR <sup>2</sup>	ESCAPE WIDTH in mm
up to 5	875
up to 20	1000
up to 200	1200

TYPE	VERSION	CLEAR GATE DIMENSION	ARTICLE NO.
MFT-360 W/AL	Wall, hinge left	360 mm	39.00.11.00
MFT-360 W/AR	Wall, hinge right	360 mm	39.00.11.01
MFT-360 S/AL	Stand, hinge left	360 mm	39.00.11.02
MFT-360 S/AR	Stand, hinge right	360 mm	39.00.11.03
MFT-485 W/AL	Wall, hinge left	485 mm	39.00.11.04
MFT-485 W/AR	Wall, hinge right	485 mm	39.00.11.05
MFT-485 S/AL	Stand, hinge left	485 mm	39.00.11.06
MFT-485 S/AR	Stand, hinge right	485 mm	39.00.11.07
MFT-685 W/AL	Wall, hinge left	685 mm	39.00.11.08
MFT-685 W/AR	Wall, hinge right	685 mm	39.00.11.09
MFT-685 S/AL	Stand, hinge left	685 mm	39.00.11.10
MFT-685 S/AR	Stand, hinge right	685 mm	39.00.11.11
MFT-875 W/AL	Wall, hinge left	875 mm	39.00.11.12
MFT-875 W/AR	Wall, hinge right	875 mm	39.00.11.13
MFT-875 S/AL	Stand, hinge left	875 mm	39.00.11.14
MFT-875 S/AR	Stand, hinge right	875 mm	39.00.11.15
MFT-1000 W/AL	Wall, hinge left	1000 mm	39.00.11.16
MFT-1000 W/AR	Wall, hinge right	1000 mm	39.00.11.17
MFT-1000 S/AL	Stand, hinge left	1000 mm	39.00.11.18
MFT-1000 S/AR	Stand, hinge right	1000 mm	39.00.11.19
MFT-1200 W/AL	Wall, hinge left	1200 mm	39.00.11.20
MFT-1200 W/AR	Wall, hinge right	1200 mm	39.00.11.21
MFT-1200 S/AL	Stand, hinge left	1200 mm	39.00.11.22
MFT-1200 S/AR	Stand, hinge right	1200 mm	39.00.11.23

**OPTIONS**

TANDEM<sup>3</sup> surface holding magnet locking system Article no. 39.00.05.07

<sup>1</sup> included in the complete surface holding magnet set, art. no. 39.00.05.06

<sup>2</sup> Workplace guideline for escape routes [ASR-A 2.3]

<sup>3</sup> With this option, two magnetic swing gates can be combined into a double swing gate. The second magnet is connected in the control box.



**TYPE GT**

# Handrail gate (escape route gate)

STAINLESS STEEL 1.4301



Escape route gate, Type GT-III, hinge, left-hand

**OPENING DIRECTION**

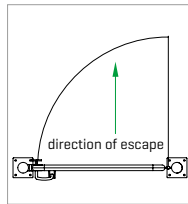

Hinge, right-hand

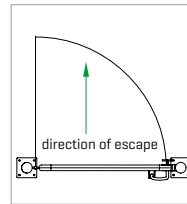

Hinge, left-hand

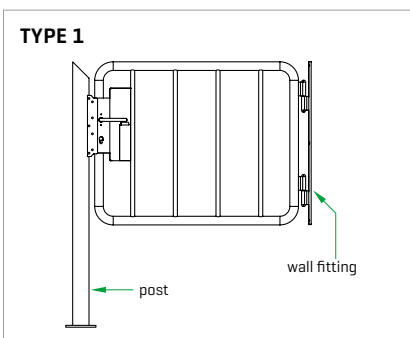

**TYPE 1**

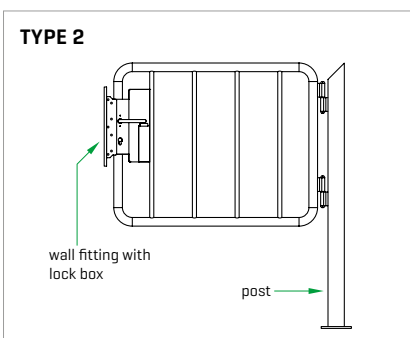

**TYPE 2**

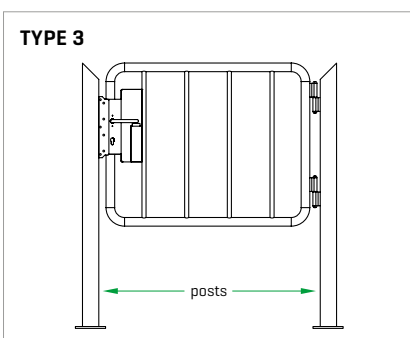

**TYPE 3**

CLEAR GATE DIMENSION	NUMBER OF PERSONS*	HINGE	ARTICLE NO.	ARTICLE NO.	ARTICLE NO.
			Type 1	Type 2	Type 3
875	up to 5	Left-hand	39.00.10.14	39.00.10.16	39.00.10.18
		Right-hand	39.00.10.15	39.00.10.17	39.00.10.19
1000	up to 20	Left-hand	39.00.10.03	39.00.10.05	39.00.10.07
		Right-hand	39.00.10.02	39.00.10.04	39.00.10.06
1200	up to 200	Left-hand	39.00.10.13	39.00.10.09	39.00.10.11
		Right-hand	39.00.10.12	39.00.10.08	39.00.10.10

\*according to ASR: Workplace provision for escape routes [ASR-A 2.3]

Optionally as escape route gate with anti-panic locking system and door guard according to DIN EN 179. Clear passage width for up to 200 employees according to ASR A2.3.

- Hygienic, cleanly welded pipe profile construction
- Version with vertical struts
- 3 different gate types and clear passage widths available
- Hinge: Opening direction LEFT or RIGHT
- Door handle both sides with knob made of rustproof stainless steel
- Standard mortise lock without profile cylinder
- Clear gate dimensions 800, 875, 900, 1,000, 1,050 und 1,200 mm [special widths on request]
- Standard height: 1,290 mm [special heights on request]

**OPTIONS**

Anti-panic-mortise lock [according to DIN EN 179] Article no. 99.80.01.62

Door guard with pre-alarm function, battery supply [9 V] Article no. 39.00.05.01

Automatic alarm cut-off for door guard Article no. 39.00.05.02

Locking by means of surface holding magnet [IP68] Article no. 39.00.05.06

On request, we manufacture handrails according to your needs!

**TYPE MGT**

# Magnetic handrail gate

STAINLESS STEEL 1.4301



- Escape-route-suitable barrier gate system with magnetic locking mechanism
- Hygienic, cleanly welded pipe profile construction
- Version with vertical struts
- 3 different gate types and clear passage widths available
- Clear gate dimensions 875, 1,000 & 1,200 mm (special widths on request)
- Clear passage width for up to 200 employees according to ASR A2.3<sup>1</sup> (for clear gate dimension 1,200 mm)
- Hinge: Opening direction LEFT or RIGHT
- Standard height: 1,300 mm (special heights on request)
- In conjunction with locking system using surface-magnet, article no. 39.00.05.06:
  - Rittal compact control cabinet in Hygienic-Design version
  - Connections for on-site systems available (e.g. fire alarm system or card reader)
  - House alarm box for emergency opening
  - Key switch for authorised opening
  - Signal horn - acoustic signal when opening via house alarm

01

CLEAR GATE DIMENSION	TYPE	VERSION	OPENING DIRECTION	NUMBER OF PERSONS according to ASR <sup>1</sup>	ESCAPE WIDTH in mm	ARTICLE NO.
875 mm	MGT-875 I-AL	Wall fitting with hinge <sup>2</sup>	Hinge, left-hand	up to 5	875	39.00.10.50
	MGT-875 I-AR	Wall fitting with hinge <sup>2</sup>	Hinge, right-hand	up to 5	875	39.00.10.51
	MGT-875 II-AL	Wall fitting with retaining plate for magnet <sup>3</sup>	Hinge, left-hand	up to 5	875	39.00.10.52
	MGT-875 II-AR	Wall fitting with retaining plate for magnet <sup>3</sup>	Hinge, right-hand	up to 5	875	39.00.10.53
	MGT-875 III-AL	Post with hinge <sup>2</sup>	Hinge, left-hand	up to 5	875	39.00.10.54
	MGT-875 III-AR	Post with hinge <sup>2</sup>	Hinge, right-hand	up to 5	875	39.00.10.55
1000 mm	MGT-1000 I-AL	Wall fitting with hinge <sup>2</sup>	Hinge, left-hand	up to 20	1000	39.00.10.56
	MGT-1000 I-AR	Wall fitting with hinge <sup>2</sup>	Hinge, right-hand	up to 20	1000	39.00.10.57
	MGT-1000 II-AL	Wall fitting with retaining plate for magnet <sup>3</sup>	Hinge, left-hand	up to 20	1000	39.00.10.58
	MGT-1000 II-AR	Wall fitting with retaining plate for magnet <sup>3</sup>	Hinge, right-hand	up to 20	1000	39.00.10.59
	MGT-1000 III-AL	Post with hinge <sup>2</sup>	Hinge, left-hand	up to 20	1000	39.00.10.60
	MGT-1000 III-AR	Post with hinge <sup>2</sup>	Hinge, right-hand	up to 20	1000	39.00.10.61
1200 mm	MGT-1200 I-AL	Wall fitting with hinge <sup>2</sup>	Hinge, left-hand	up to 200	1200	39.00.10.62
	MGT-1200 I-AR	Wall fitting with hinge <sup>2</sup>	Hinge, right-hand	up to 200	1200	39.00.10.63
	MGT-1200 II-AL	Wall fitting with retaining plate for magnet <sup>3</sup>	Hinge, left-hand	up to 200	1200	39.00.10.64
	MGT-1200 II-AR	Wall fitting with retaining plate for magnet <sup>3</sup>	Hinge, right-hand	up to 200	1200	39.00.10.65
	MGT-1200 III-AL	Post with hinge <sup>2</sup>	Hinge, left-hand	up to 200	1200	39.00.10.66
	MGT-1200 III-AR	Post with hinge <sup>2</sup>	Hinge, right-hand	up to 200	1200	39.00.10.67

<sup>1</sup> Workplace guideline for escape routes (ASR-A 2.3)

<sup>2</sup> Post with holding plate for magnet

<sup>3</sup> Post with hinge

**TYPE G**

# Handrail



Type G-I 1290



Type G-II 1290

**TYPE G-I KNEE STRAP, H 960 MM**

TYPE	LENGTH in mm	ARTICLE NO.
G-I/96-020	200	71.09.60.20
G-I/96-030	300	71.09.60.30
G-I/96-040	400	71.09.60.40
G-I/96-050	500	71.09.60.50
G-I/96-060	600	71.09.60.60
G-I/96-070	700	71.09.60.70
G-I/96-080	800	71.09.60.80
G-I/96-090	900	71.09.60.90
G-I/96-100	1000	71.09.61.00
G-I/96-110	1100	71.09.61.10
G-I/96-120	1200	71.09.61.20
G-I/96-130	1300	71.09.61.30
G-I/96-140	1400	71.09.61.40
G-I/96-150	1500	71.09.61.50
G-I/96-160	1600	71.09.61.60
G-I/96-170	1700	71.09.61.70
G-I/96-180	1800	71.09.61.80
G-I/96-190	1900	71.09.61.90
G-I/96-200	2000	71.09.62.00
G-I/96-210	2100	71.09.62.10
G-I/96-220	2200	71.09.62.20
G-I/96-230	2300	71.09.62.30
G-I/96-240	2400	71.09.62.40
G-I/96-250	2500	71.09.62.50
G-I/96-260	2600	71.09.62.60
G-I/96-270	2700	71.09.62.70
G-I/96-280	2800	71.09.62.80
G-I/96-290	2900	71.09.62.90
G-I/96-300	3000	71.09.63.00

**TYPE G-I KNEE STRAP, H 1,290 MM**

TYPE	LENGTH in mm	ARTICLE NO.
G-I/129-020	200	71.12.90.20
G-I/129-030	300	71.12.90.30
G-I/129-040	400	71.12.90.40
G-I/129-050	500	71.12.90.50
G-I/129-060	600	71.12.90.60
G-I/129-070	700	71.12.90.70
G-I/129-080	800	71.12.90.80
G-I/129-090	900	71.12.90.90
G-I/129-100	1000	71.12.91.00
G-I/129-110	1100	71.12.91.10
G-I/129-120	1200	71.12.91.20
G-I/129-130	1300	71.12.91.30
G-I/129-140	1400	71.12.91.40
G-I/129-150	1500	71.12.91.50
G-I/129-160	1600	71.12.91.60
G-I/129-170	1700	71.12.91.70
G-I/129-180	1800	71.12.91.80
G-I/129-190	1900	71.12.91.90
G-I/129-200	2000	71.12.92.00
G-I/129-210	2100	71.12.92.10
G-I/129-220	2200	71.12.92.20
G-I/129-230	2300	71.12.92.30
G-I/129-240	2400	71.12.92.40
G-I/129-250	2500	71.12.92.50
G-I/129-260	2600	71.12.92.60
G-I/129-270	2700	71.12.92.70
G-I/129-280	2800	71.12.92.80
G-I/129-290	2900	71.12.92.90
G-I/129-300	3000	71.12.93.00

**TYPE G-II VERTICAL STRUTS, H: 960 mm**

TYPE	LENGTH in mm	ARTICLE NO.
G-II 96/020	200	72.09.60.20
G-II 96/030	300	72.09.60.30
G-II 96/040	400	72.09.60.40
G-II 96/050	500	72.09.60.50
G-II 96/060	600	72.09.60.60
G-II 96/070	700	72.09.60.70
G-II 96/080	800	72.09.60.80
G-II 96/090	900	72.09.60.90
G-II 96/100	1000	72.09.61.00
G-II 96/110	1100	72.09.61.10
G-II 96/120	1200	72.09.61.20
G-II 96/130	1300	72.09.61.30
G-II 96/140	1400	72.09.61.40
G-II 96/150	1500	72.09.61.50
G-II 96/160	1600	72.09.61.60
G-II 96/170	1700	72.09.61.70
G-II 96/180	1800	72.09.61.80
G-II 96/190	1900	72.09.61.90
G-II 96/200	2000	72.09.62.00
G-II 96/210	2100	72.09.62.10
G-II 96/220	2200	72.09.62.20
G-II 96/230	2300	72.09.62.30
G-II 96/240	2400	72.09.62.40
G-II 96/250	2500	72.09.62.50
G-II 96/260	2600	72.09.62.60
G-II 96/270	2700	72.09.62.70
G-II 96/280	2800	72.09.62.80
G-II 96/290	2900	72.09.62.90
G-II 96/300	3000	72.09.63.00

- Hygienic, cleanly welded pipe profile constructions
- Screw-on floor mounting flange
- Optionally with knee strap, vertical struts or splash guard
- Standard length: 1,000 - 3,000 mm [Special lengths on request]
- 2 different standard heights: 960 and 1,290 mm
- On request, we manufacture handrails according to your needs!

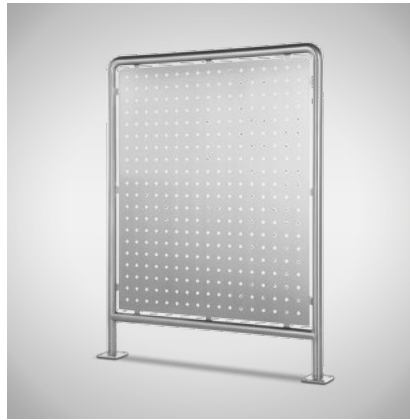

Type G-III 1290

**TYPE G-II VERTICAL STRUTS, H: 1,290 mm**

TYPE	LENGTH in mm	ARTICLE NO.
G-II 129/020	200	72.12.90.20
G-II 129/030	300	72.12.90.30
G-II 129/040	400	72.12.90.40
G-II 129/050	500	72.12.90.50
G-II 129/060	600	72.12.90.60
G-II 129/070	700	72.12.90.70
G-II 129/080	800	72.12.90.80
G-II 129/090	900	72.12.90.90
G-II 129/100	1000	72.12.91.00
G-II 129/110	1100	72.12.91.10
G-II 129/120	1200	72.12.91.20
G-II 129/130	1300	72.12.91.30
G-II 129/140	1400	72.12.91.40
G-II 129/150	1500	72.12.91.50
G-II 129/160	1600	72.12.91.60
G-II 129/170	1700	72.12.91.70
G-II 129/180	1800	72.12.91.80
G-II 129/190	1900	72.12.91.90
G-II 129/200	2000	72.12.92.00
G-II 129/210	2100	72.12.92.10
G-II 129/220	2200	72.12.92.20
G-II 129/230	2300	72.12.92.30
G-II 129/240	2400	72.12.92.40
G-II 129/250	2500	72.12.92.50
G-II 129/260	2600	72.12.92.60
G-II 129/270	2700	72.12.92.70
G-II 129/280	2800	72.12.92.80
G-II 129/290	2900	72.12.92.90
G-II 129/300	3000	72.12.93.00

**TYPE G-III SPLASH GUARD, H: 960 MM**

TYPE	LENGTH in mm	ARTICLE NO.
G-III 96/020	200	73.09.60.20
G-III 96/030	300	73.09.60.30
G-III 96/040	400	73.09.60.40
G-III 96/050	500	73.09.60.50
G-III 96/060	600	73.09.60.60
G-III 96/070	700	73.09.60.70
G-III 96/080	800	73.09.60.80
G-III 96/090	900	73.09.60.90
G-III 96/100	1000	73.09.61.00
G-III 96/110	1100	73.09.61.10
G-III 96/120	1200	73.09.61.20
G-III 96/130	1300	73.09.61.30
G-III 96/140	1400	73.09.61.40
G-III 96/150	1500	73.09.61.50
G-III 96/160	1600	73.09.61.60
G-III 96/170	1700	73.09.61.70
G-III 96/180	1800	73.09.61.80
G-III 96/190	1900	73.09.61.90
G-III 96/200	2000	73.09.62.00
G-III 96/210	2100	73.09.62.10
G-III 96/220	2200	73.09.62.20
G-III 96/230	2300	73.09.62.30
G-III 96/240	2400	73.09.62.40
G-III 96/250	2500	73.09.62.50
G-III 96/260	2600	73.09.62.60
G-III 96/270	2700	73.09.62.70
G-III 96/280	2800	73.09.62.80
G-III 96/290	2900	73.09.62.90
G-III 96/300	3000	73.09.63.00

**TYPE G-III SPLASH GUARD, H: 1,290 MM**

TYPE	LENGTH in mm	ARTICLE NO.
G-III 129/020	200	73.12.90.20
G-III 129/030	300	73.12.90.30
G-III 129/040	400	73.12.90.40
G-III 129/050	500	73.12.90.50
G-III 129/060	600	73.12.90.60
G-III 129/070	700	73.12.90.70
G-III 129/080	800	73.12.90.80
G-III 129/090	900	73.12.90.90
G-III 129/100	1000	73.12.91.00
G-III 129/110	1100	73.12.91.10
G-III 129/120	1200	73.12.91.20
G-III 129/130	1300	73.12.91.30
G-III 129/140	1400	73.12.91.40
G-III 129/150	1500	73.12.91.50
G-III 129/160	1600	73.12.91.60
G-III 129/170	1700	73.12.91.70
G-III 129/180	1800	73.12.91.80
G-III 129/190	1900	73.12.91.90
G-III 129/200	2000	73.12.92.00
G-III 129/210	2100	73.12.92.10
G-III 129/220	2200	73.12.92.20
G-III 129/230	2300	73.12.92.30
G-III 129/240	2400	73.12.92.40
G-III 129/250	2500	73.12.92.50
G-III 129/260	2600	73.12.92.60
G-III 129/270	2700	73.12.92.70
G-III 129/280	2800	73.12.92.80
G-III 129/290	2900	73.12.92.90
G-III 129/300	3000	73.12.93.00

**TYPE G-S**

**Handrail with chicane**

STAINLESS STEEL 1.4301



Type G-S II 1290



Type G-S I 960

**For forced guidance of personnel on turnstiles!**

- Hygienic, cleanly welded pipe profile construction
- Screw-on floor mounting flange
- Optionally with knee strap, vertical struts or splash guard
- 2 chicanes mounted on outer pipes for forced guidance of personnel
- Standard length: 1,000 mm
- 2 different standard heights: 960 and 1,290 mm

TYPE	VERSION	OVERALL HEIGHT	ARTICLE NO.
Length: 1,000 mm		in mm	
G-S I 960/1.000	Knee strap	960 mm	30.00.10.00
G-S I 1.290/1.000	Knee strap	1,290 mm	30.00.10.01
G-S II 960/1.000	Vertical braces	960 mm	30.00.10.02
G-S II 1.290/1.000	Vertical braces	1,290 mm	30.00.10.03
G-S III 960/1.000	Splash guard	960 mm	30.00.10.04
G-S III 1.290/1.000	Splash guard	1,290 mm	30.00.10.05



## Practical examples

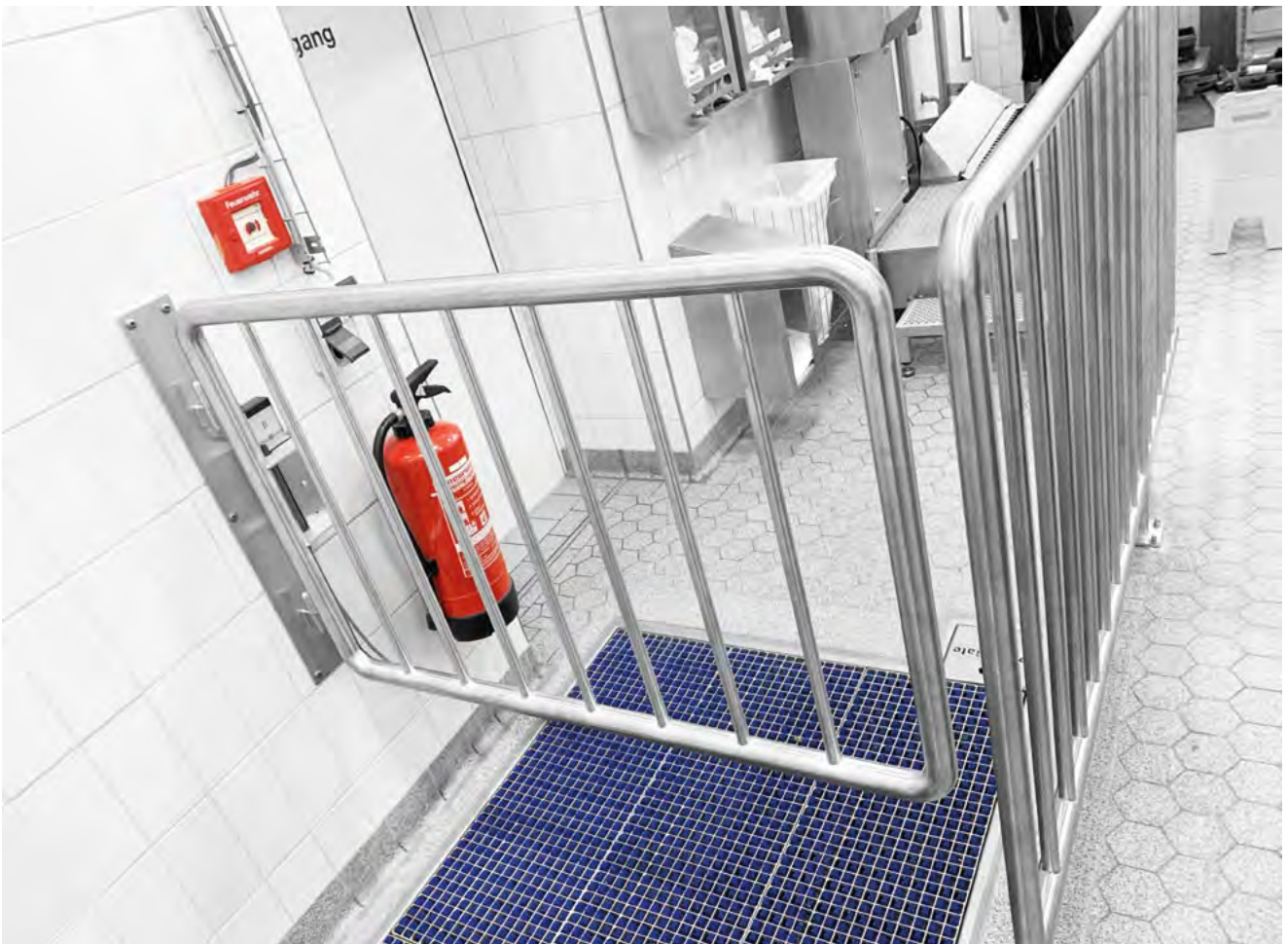

**TYPE PROFILGATE® AQUA**

# Floor hygiene station ProfilGate® aqua



Avoids everyday dirt being carried in by vehicle and passenger traffic

- Version for wet cleaning
- Cleaning mat system fundamentally consisting of:
  - Stainless steel, rust-proof dirt collection trays
  - Stable stainless steel gratings
  - Patented brush bodies made of hard or soft PVC
- Floor installation with integrated drain with odour trap
- Drain optionally with horizontal or vertical outlet
- Highest quality made in Germany

**DESCRIPTION**

Disinfection of wheels and soles without energy input. When the pre-tensioned brush irons are loaded, they are set in motion and can thus effectively clean wheels and soles. The capillary effect of the bristles ensures additional disinfection. The disinfectant solution can be dosed in the optimum mixing ratio using an optional dosing station.

In order to achieve the best possible result, the following rule of thumb should be taken into account when determining the tub length: 4 - 6 steps or triple roll unwinding.

TYPE	VOLUME in litres	DIMENSIONS W x D x H in mm	ARTICLE NO.
1,5x1 si45	22	1116 x 1026 x 45	10.00.22.16
1x2 si45	29	764 x 1995 x 45	10.00.22.10
1,5x2 si45	43	1116 x 1995 x 45	10.00.22.17
1,5x3 si45	64	1116 x 2983 x 45	10.00.22.14
2x1 si45	29	1488 x 1026 x 45	10.00.22.12
2,5x1 si45	36	1820 x 1026 x 45	10.00.22.11
2x2 si45	57	1468 x 1995 x 45	10.00.22.18
2,5x2 si45	71	1820 x 1995 x 45	10.00.22.19
2x3 si45	85	1468 x 2963 x 45	10.00.22.15
2,5x3 si45	106	1820 x 2963 x 45	10.00.22.20
3x1 si45	41.5	2172 x 1026 x 45	10.00.22.13
3x2 si45	82	2172 x 1995 x 45	10.00.22.24

**OPTIONS**

ProfilGate® fire collar for floor drains	Article no. 10.00.22.37
ProfilGate® Lifting hook set for gratings	Article no. 10.00.22.31
ProfilGate® cavity closure, single	Article no. 10.00.22.35
ProfilGate® cavity closure, solid [solid material]	Article no. 10.00.22.36
ProfilGate® cavity closure, reinforced	Article no. 10.00.22.34
ProfilGate® Type 2 edging for tiled floors	Article no. 10.00.22.32
ProfilGate® transport rack for aqua tubs	Article no. 10.00.22.40
ProfilGate® tray connector for connecting several trays	Article no. 10.00.22.33

**TYPE MD-PG**

## Mobile disinfection station

STAINLESS STEEL 1.4301



- For cleaning and disinfecting wheels
- With on- and off-ramp
- Robust and hygienic design
- Passable up to 800 kg
- Horizontal version without feet
- With on- and off-ramp
- Stable stainless steel gratings
- Patented brush bodies made of hard or soft PVC
- Water inlet and outlet (1/2" internal thread each)
- 4 transport handles made of round steel
- Cleaning / disinfection zone: L: 974 x W: 1,116 mm

TYPE	DISINFECTION ZONE	DIMENSIONS W x D x H in mm	ARTICLE NO.
MD-PG 45 Aqua	1116 x 974	1116 x 1647 x 50	10.00.02.02
MD-PG-L	1067 x 1975	1116 x 2626 x 50	10.00.02.04

**TECHNICAL DATA**

Power	approx. 280 movements per minute (brushes)
Drain	1/2" IG
Water connection	1/2" IG
Weight	134 kg
Load capacity	max. 800 kg

**TYPE DDB-R**

## Mobile disinfection bath

STAINLESS STEEL 1.4301



- For disinfecting soles and wheels
- Robust and hygienic design
- Horizontal version without feet
- With on- and off-ramp
- Anti-slip, removable gratings
- Without drain nozzle
- One side 2 handles, other side 2 rigid casters made of polyamide
- Disinfection zone: L: 1,050 x W: 985 mm

TYPE	DISINFECTION ZONE W x D in mm	DIMENSIONS W x D x H in mm	ARTICLE NO.
DDB-R	1050 x 985	1100 x 1950 x 40/125	65.00.02.60

**TYPE KH-GV**

## Can holder, lockable



- Closed, lockable
- Suitable for different container sizes
- With pitched roof
- Lid with locking mechanism for a safe and easy canister exchange

TYPE	CAPACITY	DIMENSIONS W x D x H in mm	ARTICLE NO.
KH-GV I	1 x 5 kg	240 x 225 x 512	16.10.00.41
KH-GV II	2 x 5 kg	345 x 225 x 512	16.10.00.42
KH-GV III	1 x 10 kg	240 x 265 x 520	16.10.00.43

**TYPE KH-GA**

## Can holder, lockable



- Closed, lockable
- Suitable for different container sizes
- With pitched roof
- Lid with locking mechanism for a safe and easy canister exchange

TYPE	CAPACITY	DIMENSIONS W x D x H in mm	ARTICLE NO.
KH-GA I	1 x 5 kg	240 x 225 x 512	16.10.00.14
KH-GA II	2 x 5 kg	345 x 225 x 512	16.10.00.15
KH-GA III	1 x 10 kg	240 x 265 x 520	16.10.00.17

**TYPE KB HIGHLINE**

## Can container, lockable



- Optimum and safe storage of chemicals
- Hygienic-Design
- Loss and theft protection
- Recess in the container and lid for suction hose
- Base with drainage holes

TYPE	CAPACITY	VERSION	DIMENSIONS W x D x H in mm	ARTICLE NO.
KB-ESV	1 x 24 kg	Status	295 x 290 x 630	16.10.02.01
KB-EWW	1 x 24 kg	Wall	295 x 290 x 550	16.10.02.02
KB-DSV	2 x 24 kg	Status	510 x 290 x 630	16.10.02.03
KB-DWV	2x 24 kg	Wall	510 x 290 x 550	16.10.02.04

**TYPE KB HIGHLINE**

## Can container, lockable



- Optimum and safe storage of chemicals
- Housing cover with sturdy handle, rotary bolt lock and rod locking mechanism
- Base with drainage holes
- For further information see p. 183

TYPE	CAPACITY	VERSION	DIMENSIONS W x D x H in mm	ARTICLE NO.
KB-ESA	1 x 24 kg	Status	295 x 290x 630	16.10.01.01
KB-EWA	2 x 24 kg	Wall	295 x 290x 550	16.10.01.02
KB-DSA	2 x 24 kg	Status	510 x 290 x 630	16.10.01.03
KB-DWA	2 x 24 kg	Wall	510 x 290 x 550	16.10.01.04

**TYPE KH**

## Can holder



- Open
- Wall-mounted version
- Hygienic-Design
- Stainless steel sheet with draining hole
- With hygienic corner recesses

TYPE	CAPACITY	DIMENSIONS W x D x H in mm	ARTICLE NO.
KH-II	1 x 10 kg	250 x 210 x 200	16.10.00.02
KH-III	1 x 24 kg	350 x 260 x 200	16.10.00.08

**TYPE KH-CA**

## Can holder



- Secure locking system without padlocks and other dangerous parts
- Clear instructions next to the lock
- Wall-mounted
- Master key system
- For further information see p. 183

TYPE	CAPACITY	VERSION	DIMENSIONS W x D x H in mm	ARTICLE NO.
KH-CA I	1 x 24 kg	Wall	275 x 365 x 495	05.04.00.03
KH-CA II	2 x 24 kg	Wall	545 x 365 x 495	05.04.00.04



**TYPE DA**

## Document tray



- Hygienic-Design version
- Robust sheet metal design with long slots
- Can be wall-mounted using 2 holes
- With optional brackets also suitable for mounting on handrails or housing

TYPE	VERSION	DIMENSIONS W x D x H in mm	ARTICLE NO.
DA-III	Sheet metal slotted hole	365 x 320 x 50	18.00.03.94

**OPTIONS**

Bracket for handrails Article no. 18.00.03.96

Bracket for machine cover Article no. 18.00.03.97

**TYPE EXS-HD**

## External switch box



- For best possible protection of the control technology with regard to cleaning
- Optimal access possibility for adjusting the machine parameters, such as brush operating times etc.
- Protection class IP66

TYPE	VERSION	DIMENSIONS W x D x H in mm	ARTICLE NO.
EXS-HD1	for Check-In-Station II	390 x 210 x 549	99.80.03.04
EXS-HD2	for Check-In-Station III	390 x 210 x 549	99.80.03.05
EXS-HD3	for Clean-Check	390 x 210 x 549	99.80.03.06



**TYPE MKRU**

## Knife basket chute

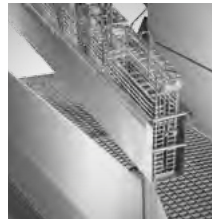

- Hygienic-Design
- Length: 2,000 mm
- Mounting with pipe clamps
- With end stop
- Special lengths on request

TYPE	MOUNTING	DIMENSIONS W x D x H in mm	ARTICLE NO.
MKRU-2000	Pipe clamps	2000 x 160 x 200	99.80.01.41

**TYPE HD-WA**

## HD-wall spacer



Provides space for the cleaning behind the housing as well!

- Hygienic-Design
- Solid material, round or flat steel
- Wall distance: 50 or 100 mm

TYPE	VERSIONS	DIMENSIONS D/W x D x H mm	ARTICLE NO.
HD-WA 50-R	Solid material round+seal	D 30 x 50	99.80.06.00
HD-WA 50-M	Solid material round	D 30 x 50	99.80.06.03
HD-WA 100-M	Solid material round	D: 30 x 100	99.80.06.01
HD-WA 50-FS	Flat steel	W 40 x 50 x 81	99.80.02.67
HD-WA 100-FS	Flat steel	W 40 x 100 x 81	99.80.03.09



# 2

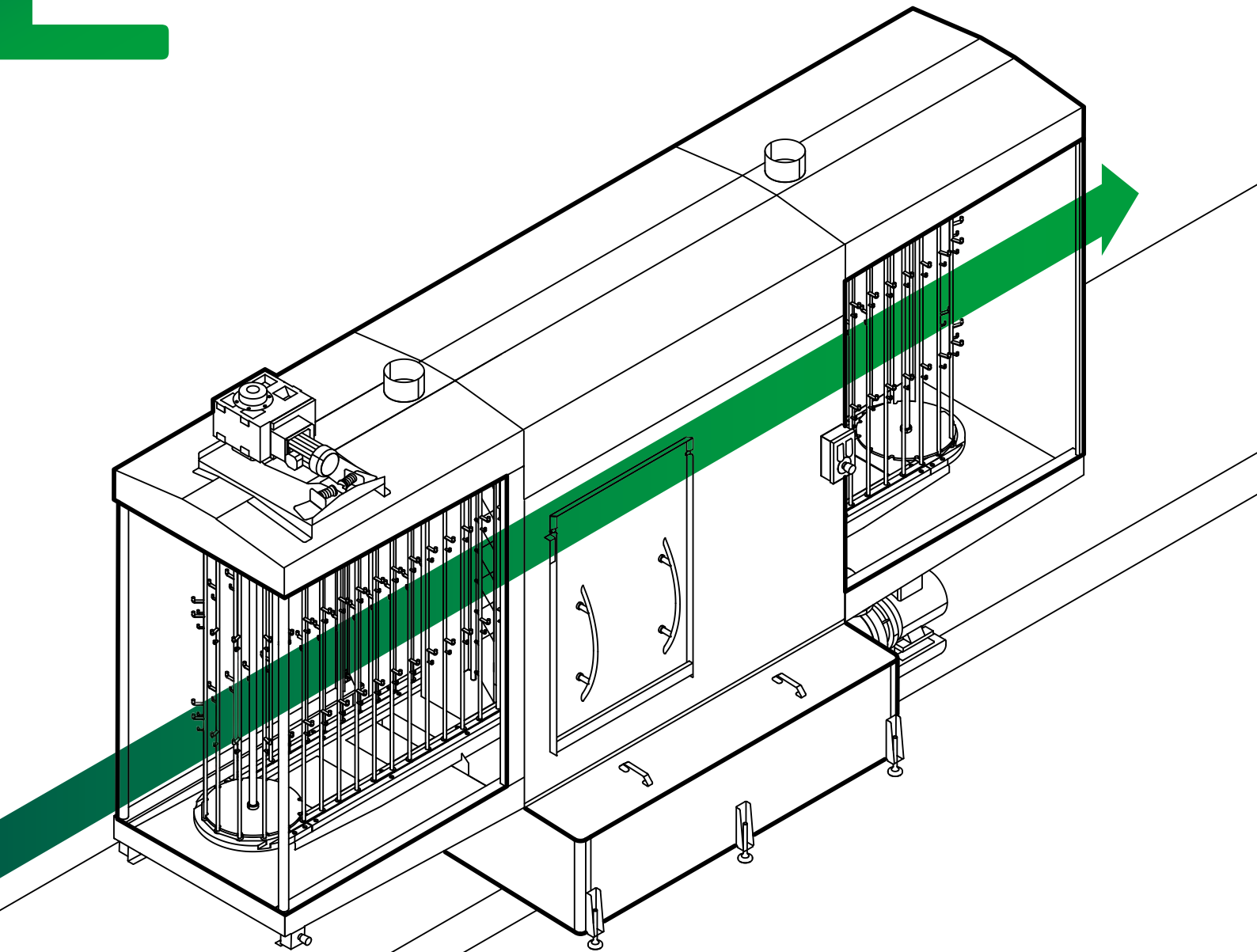

# 02

## Cleaning Technology

Knife cleaning and disinfection

---

Knife baskets, apron hanger and accessories

---

Stab protective glove and apron cleaning

---

Boots and apron cleaning stations

---

Parts and small parts wash basins

---

Appliance dishwashers

---

Cover-type washing systems

---

Smoke stick and attachment rails washing systems

---

Box and pallet washing systems

---

Cabin and pass-through washing systems

---

Universal washing systems

---

Ecolab low pressure foam technology

---



**TYPE DSB-IV**

## Disinfection basin Highline

STAINLESS STEEL 1.4301



- Highline disinfection basin for thermal disinfection of knives and sharpening steels using heating plates integrated in the body
- Robust, double-walled construction
- Wall-mounted, ready to plug in (230 V)
- Capacity: 4 knives, immersion depth: 260 mm
- Electrical heating, 1 kW
- Heating protection cover plate
- Safety shutdown
- Thermostat up to 90 °C

TYPE	CAPACITY	DIMENSIONS W x D x H in mm	ARTICLE NO.
DSB-IV Highline	4 knives	260 x 200 x 630	12.00.00.76

**TECHNICAL DATA**

Mains supply	230 V/DC permissible deviation +/-10%
Power	1.0 kW
Drain	DN 15, G 1/2" ball valve
Water connection	DN 10 pipe connection, approx. 40 °C
Protection class	IP54
Overflow	DN 20

**TYPE DSB-I**

## Disinfection basin Ecoline

STAINLESS STEEL 1.4301



- Ecoline design for thermal disinfection of knives and sharpening steels using a heating coil
- Robust and functional design
- Wall or basin mounting
- Capacity: 4 knives, 2 sharpening steels
- Standpipe valve
- Disinfection with hot water
- Electrical heating

TYPE	CAPACITY	DIMENSIONS W x D x H in mm	ARTICLE NO.
DSB-I Ecoline	4 knives, 2 sharpening steels	200 x 160 x 350	12.00.00.08

**TECHNICAL DATA**

Mains supply	230 V; 50/60 Hz
Power	1.0 kW
Drain	1/2" ball valve
Water connection	10 mm pipe
Overflow	10 mm pipe

**TYPE DSB-K**

## Cold disinfection basin

STAINLESS STEEL 1.4301



- Robust and functional design
- For wall mounting
- Cold disinfection using water and chemicals
- Capacity: 4 knives, 2 sharpening steels
- Overflow and standpipe valve
- Removable insert

TYPE	CAPACITY	DIMENSIONS W x D x H in mm	ARTICLE NO.
DSB-K	4 knives, 2 sharpening steels	206 x 170 x 335/595	12.00.00.47

**TECHNICAL DATA**

Drain	3/4" stainless steel ball valve	Overflow	Ø 20 mm
Water connection	Ø 10 mm Pipe connection		

**TYPE DSB-II**

## Disinfection basin

STAINLESS STEEL 1.4301



- For wall or basin mounting [230 V]
- Capacity: 4 knives, 2 sharpening steels and 2 hatchets
- Heating by means of a heating coil
- Immersion depth: 420 mm
- Standpipe valve
- Electrical heating, 2.0 kW
- Removable insert

TYPE	CAPACITY	DIMENSIONS W x D x H in mm	ARTICLE NO.
DSB-II Ecoline	4 knives, 2 sharpening steels	375 x 225/260 x 580	12.00.00.31

**TECHNICAL DATA**

Mains supply	230 V; 50/60 Hz	Drain	25 mm pipe socket
Power	2x 1.0 kW	Water connection	10 mm pipe connection

**TYPE DSB-MB/K**

## Cold disinfection basin

STAINLESS STEEL 1.4301



- Robust and functional design
- For wall mounting
- Cold disinfection using water and chemicals
- Capacity: 4 knives, 2 sharpening steels, 1 hatchet
- Overflow and standpipe valve
- Removable insert

TYPE	CAPACITY	DIMENSIONS W x D x H in mm	ARTICLE NO.
DSB-MB-K	4 knives, 2 sharpening steels, 1 hatchet	375 x 225 x 580/ 840	12.00.02.47

**TECHNICAL DATA**

Drain	3/4" stainless steel ball valve	Overflow	Ø 20 mm
Water connection	Ø 10 mm Pipe connection		

**TYPE DSB-MK**

# Knife basket disinfection basin

STAINLESS STEEL 1.4301



Type DSB-MK 1



Type DSB-MK 8

**DESCRIPTION**

Prior to disinfecting the knife baskets, clean them with suitable cleaning agents.

Dirt adhesions impair the disinfection effect. Damage to the knife basket surface favours the adhesion of dirt and germs. Therefore, defective knife baskets should be immediately replaced.

Once the knife basket disinfection basin has reached the required temperature (> 82 °C) by itself, the knife baskets are hung on the holder inside the basin. The subsequent retention period in the basin is decisive for the extent of germ elimination.

- Robust, double-walled construction
- Version for wall mounting [MK 1] or floor model [MK 2 - 8]
- Electrical heating
- Capacity depending on the relevant model:
  - 1, 2, 5, or 8 standard knife baskets
- Stand pipe overflow valve
- Water outlet elbow with flow regulator  
(only Type DSB-MK 2, 5 + 8)

TYPE	CAPACITY	DIMENSIONS W x D x H in mm	ARTICLE NO.
DSB-MK 1	1 knife basket	510 x 290 x 820	12.00.00.27
DSB-MK 2	2 knife baskets	510 x 500 x 875	12.00.00.17
DSB-MK 5	5 knife baskets	1060 x 470 x 880	12.00.00.01
DSB-MK 8	8 knife baskets	1510 x 470 x 880	12.00.00.52



Type DSB-MK 8 Interior

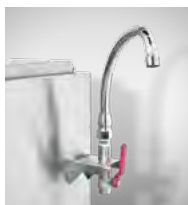

Type DSB-MK 8 Water tap

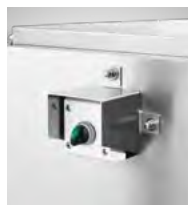

Type DSB-MK 8 Main switch

**TECHNICAL DATA DSB-MK 1**

Mains supply	230 V; 50/60 Hz
Connected load	2.0 kW
Water inlet / outlet	1/2" ball valve

**TECHNICAL DATA DSB-MK 2 + 5 + 8**

Mains supply	400 V; 50/60 Hz
Connected load	9.0 kW
Water inlet	1/2"
Water drain	1 1/2" [DN 40]

**TYPE STERI-KING**

# Knife basket disinfection tunnel

STAINLESS STEEL 1.4301



For walk-through disinfection of the knife baskets by means of highly effective active oxygen.

- Robust and functional MOHN-design, Material thicknesses 2 to 4 mm
- Capacity approx. 300 knife baskets per hour
- Start of detergent wetting does not take place until sensor recognition of the knife basket [saving of chemicals and water]
- Disinfection by means of a water/chemicals mixture
- Infeed conveyor 500 mm
- Disinfection tunnel 600 mm with 2 nozzle arms for complete wetting of the knife baskets
- Outfeed conveyor 1,000 mm
- Optionally with additional 1,000 mm gravitational roller conveyor as buffer section in the outfeed area, art.-no. 15.00.00.32

TYPE	POWER/HOUR	DIMENSIONS	ARTICLE NO.
		W x D x H in mm	
Steri-King	300 knife baskets	2000 x 665 x 1680	15.00.00.31

**TECHNICAL DATA**

Mains supply	400 V/AC; 3 N; 50 Hz
Power	1 kW [approx. 16 A]
Water connection	G 3/4", min. 1 bar, max. 6 bar, 2 - 6 °dH, cold
Drain connection	DN 50
Weight	350 kg
Volume	75 dB



MKRM-D continuous knife basket cleaning machine, see page 95

**TYPE MKDR**

## Knife basket pressure cleaner

---



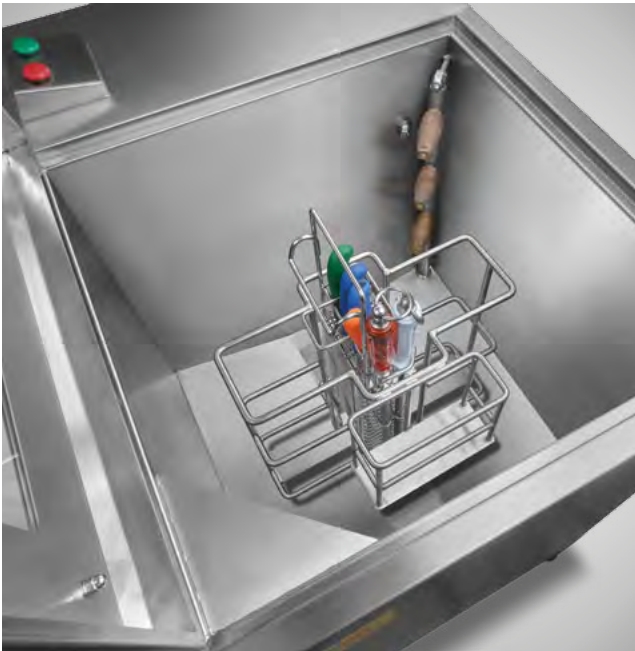

02

- Highly effective high-pressure knife basket cleaning
- Robust and hygienic MOHN construction
- Hygienically clean high-pressure cleaning in 10 - 15 seconds!
- Hygienically clean thanks to a water/chemical mixture
- Dosage + duration of cleaning is adjustable
- Capacity: 1 knife basket per cleaning process
- Variable: Cleans large and small knife baskets
- Ergonomic operating height, simple one-button operation
- Lid protection by means of proximity switch
- Incl. can holder, attached to the side

TYPE	PROGRAM DURATION	DIMENSIONS W x D x H in mm	ARTICLE NO.
MKDR	10 - 15 seconds	900 x 680 x 1060/1112	15.00.00.27

**TECHNICAL DATA**

Mains supply	400 V; 50/60 Hz
Connected load	5,6 kW
Water	3/4" - min. 2.5 bar
Drain	1 1/2"

**OPTIONS**

Knife baskets	on request
---------------	------------

**TYPE MKRM-T**

# Knife basket cleaning machine

STAINLESS STEEL 1.4301



Type MKRM-T 12/24

- Cleaning and disinfection of knife baskets & small parts
- Robust, double-walled construction
- Compatible for small and large knife baskets
- Electrically heated version
- Minimum time and energy requirement
- 2 washing programmes

TYPE	CAPACITY Knife baskets	DIMENSIONS W x D x H in mm	ARTICLE NO.
MKRM-T 12/24	12 gr. / 24 kl.*	920 x 1100 x 1100	15.00.00.41

\*kl. = small Knife baskets, gr. = large Knife baskets

**TECHNICAL DATA**

Mains supply	400V; 50/60 Hz [63 A]
Connected load	14 kW
Water	MW 3/4" [3 - 6 bar], max. 40 °C
Drain	2" [DN 50]

**DESCRIPTION**

The MKRM-T type cleaning machines have been designed for the fully automatic cleaning and disinfection of knife baskets.

By opening the hinged lid, the knife baskets can be hung from above into the machine's special fixtures. Once the lid is closed and the start button is pressed, the fully automatic cleaning and disinfection program is initiated. The PLC-control is freely configurable and comes factory-equipped with two program variants (cleaning and cleaning followed by disinfection).

Thermal disinfection occurs at the end of the cleaning process and is carried out here at a temperature of 93°C with an exposure time of five minutes. The high temperature at the end of the program eliminates the risk of recontamination by the rinse water and enhances the drying results following the final rinse phase. This process is particularly gentle on materials.

The standard version of the machine can be adapted to the specific requirements of the need at hand.

**FUNCTIONAL SEQUENCE**

- Machine fills tank with 24 litres of fresh water + chemicals [peristaltic pump]
- Machine washes for approx. 5 minutes depending on the water inlet temperature
- Machine pumps out water
- Machine refills tank with 24 litres. Fresh water
- Start rinse programme, machine has 2 rinse programmes:
  - Progr. 1: Rinse [approx. 1 minute]
  - Progr. 2: Rinse with hot water 89 °C [approx. 5 minutes]
- Water is heated by means of a 10 kW electric heater



**TYPE MKRM-D**

# Knife basket pass-through cleaning machine

STAINLESS STEEL 1.4301



Type MKRM-D I

- Completely double-walled, soundproof and heat insulated machine housing made of one piece and completely welded, low energy consumption
- Washing frames can be removed and cleaned without any tools, forced positioning
- Round hole stainless steel nozzles with large passage, good cleaning effect and insensitive to pollution
- Infeed conveyor: 1,000 mm / outfeed conveyor: 1,500 mm
- Speed up to 300 (MKRM-D II: 600) knife baskets/h
- Passage width 130 mm per lane, max. passage height 485 mm, Housing width 600 mm (MKRM-D II: 800 mm)
- 1,800 mm long active washing and rinsing zone
- Tank volume approx. 200 l (MKRM-D II: 300l) with plate filter that can be removed via the maintenance door
- Electrical heating 10 kW (MKRM-D II: 20 kW) or direct steam for washing tank
- MKRM-D I: Strong stainless steel centrifugal pump with 3 KW output, 600l/min circulation at 2 bar wash pressure, distributed on 40 stainless steel flat jet nozzles in easily removable nozzle arms
- MKRM-D II: Strong stainless steel centrifugal pump with 4 KW output, 1,200l/min circulation at 1.8 bar wash pressure, distributed on 70 stainless steel flat jet nozzles in easily removable nozzle arms
- Clear rinsing with fresh water, can be adjusted sensitively via pressure reducers
- Fresh water inlet temperature approx. 45° C, recommended rinsing temperature 85°C, heatable via electrical heater or steam, see options
- Water consumption: approx.350 - 400 l/h (MKRM-D II: approx. 450 - 500 l/h)

TYPE	VERSION	DIMENSIONS	ARTICLE NO.
		W* x D x H in mm	
MKRM-D I	Single lane	4300 x 600 x 1500	15.00.00.17
MKRM-D II	Two lanes	4300 x 800 x 1500	15.00.00.18

\*Infeed conveyor: 1,000 mm / outfeed conveyor: 1,500 mm including

**TECHNICAL DATA**

Mains supply	3~ 400 V; 50 Hz
Water	3/4"; 1 - 6 bar
Drain	DN 50

**MACHINE CONNECTIONS**

Mains supply	3~ 400 V - 50 Hz; 14 kW (MKRM-D II: 25 kW) with electrical heater in the tank
Fresh water	3/4"; 1 - 6 bar; min. 45 °C
Waste water	DN50
Exhaust air socket for suction	1x DN 250; 1,500 m³/h at 500 Pa

**OPTIONS**

Direct steam instead of electrical heating in the washing tank	Article no. 11.10.02.60
Hot water or thermal oil heat exchanger for washing tank	Article no. 11.10.02.61
Steam heat exchanger for washing tank	Article no. 11.10.02.62
Electric boiler 1x 10 kW fresh water heating approx. 30 - 40 °C for rinsing	Article no. 11.10.02.57
Electric boiler 2x 10 kW fresh water heating approx. 45 - 50 °C for rinsing	Article no. 11.10.02.58
Steam heat exchanger, direct and indirect, for clear rinsing	Article no. 11.10.02.63
Waste water heat exchanger, for warming up fresh water for clear rinsing, Temperature increase approx. 10 - 15 °C	Article no. 11.10.02.59
Vapour exhaust in the infeed and outfeed area, including stainless steel piping DN 250, output approx. 1,500 m³/h at 500 Pa	Article no. 11.10.02.64

02

**TYPE MK**

**Knife basket**

STAINLESS STEEL 1.4301



Type MK 2/2/1



Type MK 7/2/1

- Electrolytically polished surfaces
- With hand or transport handle
- With plastic blade protection
- Hinged restraining bar for padlock
- For knives with a blade length of max. 240 mm
- Sharpening steels with a diameter of max. 23 mm
- Depending on model: Holder for stab protective glove and knife grinder
- Delivery takes place without content!
- Knives, sharpening steels, stab protective glove, knife grinder

TYPE	DIMENSIONS	ARTICLE NO.
	L x W x H in mm	
MK 2/2	157 x 107 x 480	19.00.00.34
MK 2/2/1	157 x 107 x 480	19.00.00.35
MK 4/2	185 x 107 x 480	19.00.00.03
MK 4/2/1	185 x 107 x 480	19.00.00.14
MK 4/2/1/1	185 x 115 x 475	19.00.00.31
MK 7/2/1	385 x 107 x 480	19.00.00.07
MK 10/2	360 x 115 x 450	19.00.00.00
MK 10/2/1	360 x 118 x 470	19.00.00.43
MK 10/2/1/1	400 x 115 x 490	19.00.00.01

Example: MK 4/2/1/1  
4 knives, 2 sharpening steels, 1 stab protective glove, 1 knife grinder

**TYPE MKH**

**Knife basket holders**

STAINLESS STEEL 1.4301



Type MKH-10



Type MKH-K3



Type MKH-E

TYPE*	DIMENSIONS L x D x H in mm	ARTICLE NO.
MKH-1	150 x 450 x 200	19.00.00.51
MKH-2	300 x 450 x 200	19.00.00.52
MKH-3	450 x 450 x 200	19.00.00.53
MKH-4	600 x 450 x 200	19.00.00.54
MKH-5	750 x 450 x 200	19.00.00.55
MKH-6	900 x 450 x 200	19.00.00.56
MKH-7	1050 x 450 x 200	19.00.00.57
MKH-8	1200 x 450 x 200	19.00.00.58
MKH-9	1350 x 450 x 200	19.00.00.59
MKH-10	1500 x 450 x 200	19.00.00.60

\*without safety chain

TYPE*	DIMENSIONS L x D x H in mm	ARTICLE NO.
MKH-1K	150 x 450 x 200	19.00.00.61
MKH-2K	300 x 450 x 200	19.00.00.62
MKH-3K	450 x 450 x 200	19.00.00.63
MKH-4K	600 x 450 x 200	19.00.00.64
MKH-5K	750 x 450 x 200	19.00.00.65
MKH-6K	900 x 450 x 200	19.00.00.66
MKH-7K	1050 x 450 x 200	19.00.00.67
MKH-8K	1200 x 450 x 200	19.00.00.68
MKH-9K	1350 x 450 x 200	19.00.00.69
MKH-10K	1500 x 450 x 200	19.00.00.70

\*with safety chain

**TYPE MKH + MKH-K**

- For the orderly storage of knife baskets
- Capacity: 1 to 10 baskets depending on version
- Robust construction for wall mounting
- Compatible for small and large knife baskets
- with [MKH-K] or without [MKH] safety chain [L: 200mm]
- 150 mm space requirement per knife basket

TYPE	DIMENSIONS W x D x H in mm	ARTICLE NO.
MKH-E2	110 x 36 x 50	19.00.00.40
MKH-E4	160 x 36 x 50	19.00.00.41
MKH-E7+10	330 x 36 x 50	19.00.00.42

**TYPE MKH-E**

- Stable knife basket holder for wall or table mounting
- Made from 2 mm thick stainless steel sheet

**TYPE MKH-E2**

- For holding knife baskets MK 2/2 and MK 2/2/1

**TYPE MKH-E4**

- For holding knife baskets MK 4/2 and MK 4/2/1

**TYPE MKH-E7+10**

- For holding knife baskets MK 7/2/1 and MK 10/2/1

02

**TYPE MK-S**

**Knife basket safety cabinet**

STAINLESS STEEL 1.4301

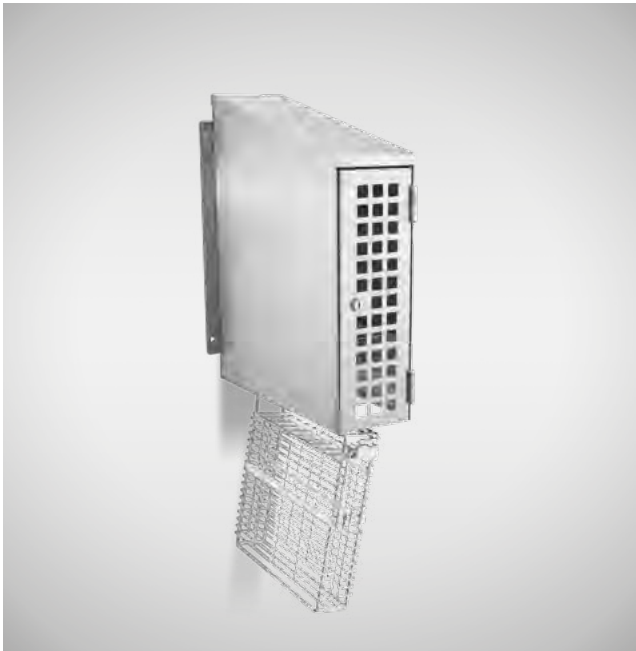

Type MK-S 1

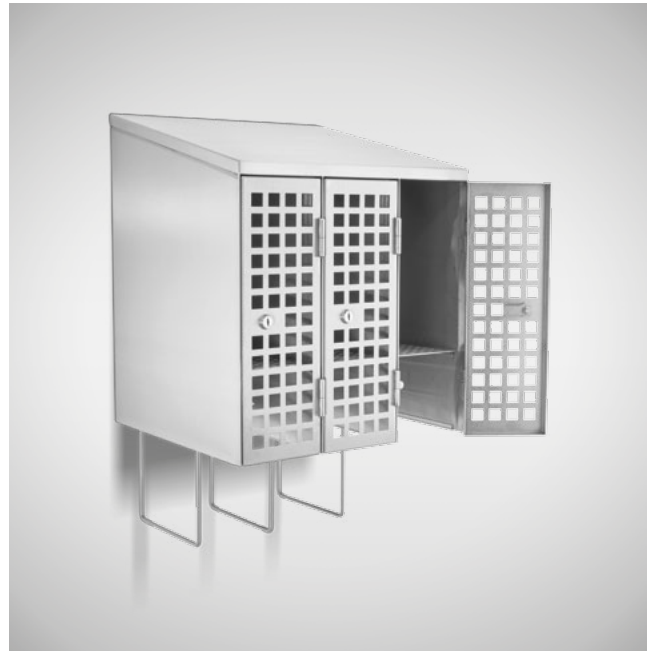

Type MK-S 3

- Knife basket safety cabinet, Type MK-S
- 1 to 10 block for wall mounting
- For safe and hygienic storage of knife basket, glove or apron
- Hygienic design with 100 mm pitched roof
- Floor and hinged door with square holes
- On request with numbering
- Compatible for small and large knife baskets
- Lockable and secured against unauthorized access by means of cylinder lock
- Dimensions: W: 150 to 1,500 mm  
[depending on version x T 440 x H 450/550 mm]

**OPTIONS**

Numbering	on request
Rotary bolt lock instead of cylinder lock	on request
Stainless steel padlock	Article no. 99.80.03.50

TYPE	DIMENSIONS	ARTICLE NO.
	L in mm	
MK-S 1	150	19.00.00.20
MK-S 2	300	19.00.00.21
MK-S 3	450	19.00.00.22
MK-S 4	600	19.00.00.23
MK-S 5	750	19.00.00.24
MK-S 6	900	19.00.00.25
MK-S 7	1050	19.00.00.26
MK-S 8	1200	19.00.00.27
MK-S 9	1350	19.00.00.28
MK-S 10	1500	19.00.00.29

**TYPE MKTW**

# Knife basket transport trolley

STAINLESS STEEL 1.4301



02

- Robust and functional design
- Double-sided version
- Capacity: 40 large or 80 small knife baskets
- 2 swivel casters and 2 fixed casters made of polyamide [D: 125 mm]
- Construction completely made of open profile or flat material
- with ergonomic push handle

TYPE	CAPACITY	DIMENSIONS W x D x H in mm	ARTICLE NO.
MKTW	40 gr or 80 kl*	800 x 1320 x 1250	19.00.01.04

\*kl. = small Knife baskets, gr. = large Knife baskets

**OPTIONS**

Swivel casters with locking mechanism

Safety chain (for customer-installed protection of the knife baskets by means of a U-lock)

**TYPE SHR-N**

## Stab protective glove low pressure cleaner

STAINLESS STEEL 1.4301



- For preliminary or intermediate cleaning of the stab protective gloves
- Hygienic-Design with pitched roof
- Wall-mounted, optionally with foot frame, Article no. 10.00.00.77
- Low-pressure cleaning by means of customer-provided pressure supply
- Contactless sensor control
- Application amount adjustable via nozzle system

TYPE	BOOSTER PUMP	DIMENSIONS W x D x H in mm	ARTICLE NO.
SHR-N*	No	405 x 300 x 595	15.00.00.01

\*SHR-N: min. 12 - 25 bar water pressure required

**TECHNICAL DATA**

Mains supply	400 V; 50/60 Hz
Water	3/4", max. 40°C
Drain	1 1/2"

**TYPE SHR-H**

## Stab protective glove high-pressure cleaner

STAINLESS STEEL 1.4301



For small and medium company sizes

- Highly effective cleaning of the stab protective gloves within 10 sec.
- Operation by means of foot pedal; activates high-pressure cleaning (120 bar)
- Rotating high-pressure jet for optimal cleaning results
- Application amount can be set via dosing system
- Hygienically deep-drawn inner container
- Can holder for detergent mounted on the device
- Max. inlet water temperature: 43 °C

TYPE	PROGRAM DURATION	DIMENSIONS W x D x H in mm	ARTICLE NO.
SHR-H	10 - 15 seconds	610* x 640 x 1500	15.00.00.24

\*Plus can bracket (width: + 243 mm)

**TECHNICAL DATA**

Mains supply	400 V; 50/60 Hz
Connected load	2.6 kW
Water	3/4"- 2.5 bar
Drain	1 1/2"



**TYPE SSR-H**

## Stab protective apron high-pressure cleaner Type SSR-H

STAINLESS STEEL 1.4301



For small and medium company sizes

- Highly effective cleaning of the stab protective aprons within 10 sec.
- Operation by means of foot pedal; activates high-pressure cleaning (120 bar)
- Rotating high-pressure jet for optimal cleaning results
- Application amount can be set via dosing system
- Hygienically deep-drawn inner container
- Can holder for detergent mounted on the device
- Max. inlet water temperature: 43 °C

TYPE	PROGRAM DURATION	DIMENSIONS W x D x H in mm	ARTICLE NO.
SSR-H	10 - 15 seconds	800* x 750 x 1,480	15.00.00.28

\*Plus can bracket (width: + 253 mm)

**TECHNICAL DATA**

Mains supply	400 V; 50/60 Hz
Connected load	5.6 kW
Water	3/4" - 2.5 bar
Drain	1 1/2"

**TYPE APRON MASTER**

## Apron cleaning machine

STAINLESS STEEL 1.4301



- For cleaning rubber or stab protective aprons
- Robust & functional design
- Brush roller with direction of rotation change via switch rod
- Ergonomic operator's height
- Application amount can be set via dosing system
- Sensor-controlled brush roller rotation
- Integrated can holder
- Rinse function

TYPE	CLEANING STATION	DIMENSIONS W x D x H in mm	ARTICLE NO.
Apron Master	1	1704 x 422 x 806	16.00.01.01

**TECHNICAL DATA**

Mains supply	400 V; 50/60 Hz
Connected load	0.5 kW
Water	3/4", max. 43°C
Drain	1 1/2"
DN	50 nozzles

02

**TYPE STWA-I**

## Boot and apron cleaning station

STAINLESS STEEL 1.4301



For manual cleaning of aprons & soles or boots

- Robust and functional design
- Incl. hose installation, brush and Spray gun

- Easy installation and commissioning
- Water-flown hand brush
- Splash spray for fast pre-cleaning
- Height-adjustable feet
- Spray gun for quick pre-cleaning

TYPE	VERSION	DIMENSIONS W x D x H in mm	ARTICLE NO.
STWA-I	Status	1050 x 540 x 1850	16.00.00.09
STWA-IV	Wall	1400 x 582 x 1850	16.00.00.17

**TECHNICAL DATA**

Water inlet	1/2", max. 43°C	Water drain	1 1/2"
-------------	-----------------	-------------	--------

**TYPE STWA-II**

## Sole, boot and apron cleaning stations

STAINLESS STEEL 1.4301



For machine sole cleaning and manual cleaning of boot shafts and aprons

- Robust and functional design
- Hand contact sensor operation
- Mechanical sole cleaning

- Water-flown hand brush
- Splash spray for fast pre-cleaning
- Height-adjustable feet

TYPE	DIMENSIONS W x D x H in mm	ARTICLE NO.
STWA-II	1450 x 580 x 2025	16.10.00.00

**TECHNICAL DATA**

Water inlet	2x 3/4"	Mains supply	230 V; N/PE; 50/60 Hz
Water drain	DN 50	Power	0.2 kW

**TYPE STWA-III**

## Boot and apron cleaning station

STAINLESS STEEL 1.4301



For mechanical sole or boot cleaning & manual cleaning of the aprons

- Robust and functional design
- Hand contact sensor operation

- Mechanical sole cleaning
- Water-flown hand brush
- Splash spray for fast pre-cleaning
- Height-adjustable feet

TYPE	DIMENSIONS W x D x H in mm	ARTICLE NO.
STWA-III	1700 x 630 x 2025	16.10.00.01

**TECHNICAL DATA**

Water inlet	2x 3/4"	Power	0.75 kW
Water drain	1 1/2"	Protection class	IP65
Mains supply	3x 400 V; 50/60 Hz		

**TYPE SRK**

## Apron cleaning cabinet

STAINLESS STEEL 1.4301



Type SRK-F

- For cleaning the apron at the workplace
- Robust and functional design
- Swivelling shower head
- Side splash guards
- Removable step grate
- Sensor-controlled [SRK-S] or foot-operated [SRK-F]
- Ground clearance 180 mm

TYPE	VERSION	DIMENSIONS	ARTICLE NO.
		W x D x H in mm	
SRK-S	Sensor-controlled	750 x 700 x 1680	16.00.00.03
SRK-F	Foot confirmation	750 x 700 x 1680	16.00.00.15

**TECHNICAL DATA**

Mains supply	230 V; 50 Hz [Type SRK-S only]
Drain	1 1/2"
Water connection	1/2"

**TYPE SW-TM 11**

## Apron cleaning machine

STAINLESS STEEL 1.4301



- Machine drum cleaning of rubber and pricking aprons
- Detergent dispenser with freely programmable control
- Brand product from "MIELE" with electric heating
- Drum volume 110 litres, maximum load weight 12 kg
- Low water and energy consumption thanks to the lye tank
- Optimal cleaning and maintenance with patented Gentle Drum 2.0
- High user convenience with automatic door closure
- Extreme smoothness of operation thanks to an efficient spring-within-spring system
- Door opening  $\varnothing$  415 mm
- Door opening angle 180°, door hinge right

TYPE	VERSION	DIMENSIONS	ARTICLE NO.
		W x D x H in mm	
SW-TM 11 kg	Electrical	1352 x 799 x 940	16.00.00.20

**TECHNICAL DATA**

Mains supply	3N 380-415 V; 50/60 Hz
Power	9,6 kW
Drain	DN 70
Water connection	2x 1/2" with 3/4" screw connection [cold] 1x 1/2" with 3/4" screw connection [warm]
Fuse protection	3x 16 A
Drum volume	110 kg
Spin speed	max. 1,150 rpm

**TYPE SB**

## Apron hanger

STAINLESS STEEL 1.4301



Type SB and SB-M

**TYPE SB**

- For hygienic storage of aprons
- Stable version made of stainless steel full material
- Suitable for all apron types
- Optimal drying due to automatic spreading
- Distance protection (75 mm) for effective apron drying
- Suspension on round tube wardrobes

**TYPE SB-M**

- Stable round tube construction (tube ends: tightly welded!)
- Suitable for all apron types and sizes
- Optimal drying through automatic spreading
- Distance protection of the aprons by 75 mm wide suspension
- Suspension on round tube wardrobes

TYPE	VERSION	DIMENSIONS	ARTICLE NO.
		L x W x H in mm	
SB	Round steel 6 mm	1125 x 75 x 776	18.00.00.03
SB-M	Round tube 25 mm	1120 x 75 x 710	18.00.01.35

**TYPE S-WG/ -SG 12**

## Apron wardrobe

STAINLESS STEEL 1.4301



Stand frame,  
Type SSG-HL 1000

Wall frame,  
Type SWG-HL 1000

- Apron wardrobes
- For hanging apron hangers
- Wall-mounted, as standing version, or as mobile version
- Hygienic-Design
- Robust, fully welded version

TYPE	VERSION	DIMENSIONS	ARTICLE NO.
		W x D x H in mm	
SWG-HL 1000	wall-mounted	1000 x 670 x 680	18.00.02.90
SWG-HL 1500	wall-mounted	1500 x 670 x 680	18.00.02.91
SWG-HL 2000	wall-mounted	2000 x 670 x 680	18.00.02.92
SSG-HL 1000	Floor version	1000 x 800 x 1845	18.00.02.93
SSG-HL 1500	Floor version	1500 x 800 x 1845	18.00.02.94
SSG-HL 2000	Floor version	2000 x 800 x 1845	18.00.02.95
SSG-HL 1000 F	Mobile	1000 x 800 x 1845	18.00.02.96
SSG-HL 1500 F	Mobile	1500 x 800 x 1845	18.00.02.97
SSG-HL 2000 F	Mobile	2000 x 800 x 1845	18.00.02.98

**TYPE TW**

**Parts wash station**

STAINLESS STEEL 1.4301



Type TW-S 120/65



Type TW-S 70/62

- Firmly welded version
- 2 different versions [TW-K] or [TW-S or G/S]
- Mobile version with 2 rigid casters and 2 swivel casters with locking mechanism
- Perforated support grid or grating
- Drain with screw cap DN 50
- Optionally with cleaning gun [air + water], Article no. 12.00.00.71
- Including 500 mm drip plate, removable [TW-G/ S]
- Media connections from above [cold + warm water]  
Internal distribution to extraction points for dish washer and single-lever mixer [TW-G/ S]

TYPE	VERSION	DIMENSIONS	ARTICLE NO.
		W x D x H in mm	
TW-K/ WL <sup>1</sup>	Wall-mounted	800 x 600 x 1100	12.00.00.63
TW-K/ WR <sup>2</sup>	Wall-mounted	800 x 600 x 1100	12.00.00.64
TW-S 70/62	Stand frame	700 x 620/ 720 x 850/ 1450	12.00.00.60
TW-S 120/65	Stand frame	1200 x 650/ 750 x 850/ 1450	12.00.00.61
TW-S 150/65	Stand frame	1500 x 650/ 750 x 850/ 1450	12.00.00.62
TW-G/ S	Stand frame	1500 x 560 x 1450	11.10.00.90

<sup>1</sup> wall-hung, left

<sup>2</sup> wall-hung, right



Type TW-K/WL with option 12.00.00.71 Cleaning gun [air + water]



Type TW-G/ S + Options

**OPTIONS**

Dishwashing shower, 2 hole, wall	Article no. 93.00.00.36
Single lever mixer, Wall	Article no. 11.10.00.93
Cleaning gun [Air + Water]	Article no. 12.00.00.71
Hand eye shower with shower head	Article no. 11.10.00.94

## Practical examples of sink units

---

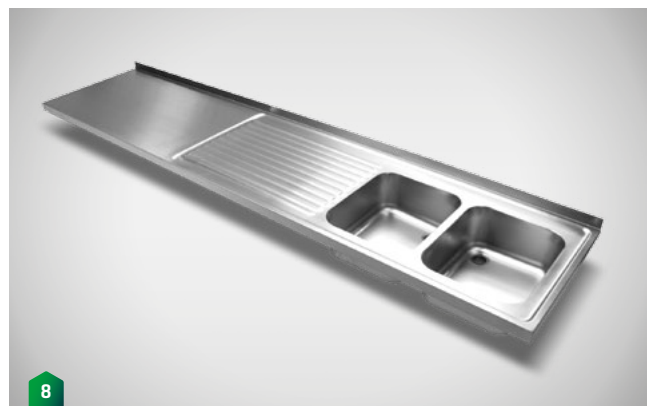





We manufacture all sink units according to your wishes!



# ENQUIRY FORM SINK UNITS + SINK CABINETS PART 1/2

## STANDARD

### 1 DIMENSIONS

Width (max. 3800):	mm
Depth:	mm
Height:	mm

### REMARK

Please chose between a standard - (Part 4) or special sink (Part 5 - 9).

We manufacture all sinks according to your wishes!

- Fill out the complete inquiry sheet
- Either fax us the inquiry sheet or scan it in and send to us by mail:

F +49 [0] 23 54.94 45-299

M info@mohn-gmbh.com

<b>COMPANY</b>	
<b>NAME</b>	
<b>PHONE</b>	
<b>MAIL</b>	

### 2 FAUCETS

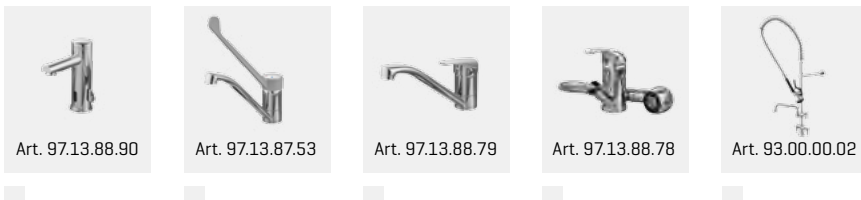

### 3 SINK SUB STRUCTURE

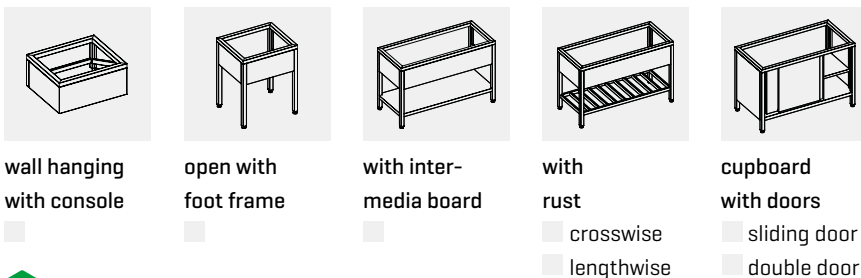

### 4 STANDARD COVER

Only fill out, when a special sink (Part 5 - 9) is not required.

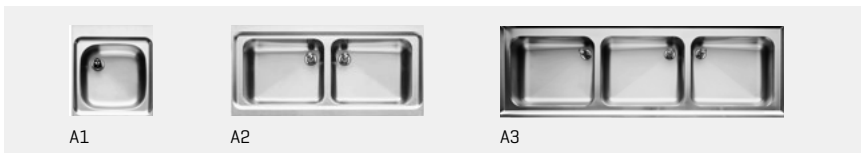

#### A1 - Single

- 370 x 340 x 150
- 400 x 400 x 200
- 500 x 500 x 250
- 600 x 600 x 300

#### A2 - Double

- 400 x 400 x 200
- 500 x 400 x 250
- 500 x 500 x 250
- 600 x 500 x 250
- 600 x 600 x 300

#### A3 - Triple

- 600 x 500 x 250

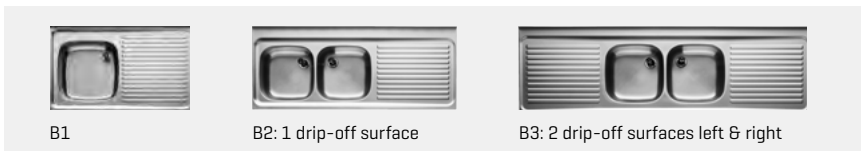

#### B1 - Single

- 400 x 400 x 200
- 400 x 400 x 300
- 500 x 400 x 250
- 500 x 500 x 250
- 600 x 500 x 250

#### B2 - Double

- 400 x 400 x 200
- 400 x 400 x 250
- 400 x 500 x 250
- 500 x 400 x 250
- 600 x 500 x 250
- 600 x 600 x 300

#### B3 - Triple

- 400 x 400 x 200
- 500 x 400 x 250
- 500 x 500 x 250

- Sink left
- Sink right

- Sink left
- Sink right

## ENQUIRY FORM SINK UNITS + SINK CABINETS PART 2/2

### SPECIAL SINK

#### 5 DRIP-OFF SURFACE

none  molded  smooth

Drip-off surface without slope, however free drainage to the sink.  
Max. 800mm long (molded).

Length: \_\_\_\_\_ mm

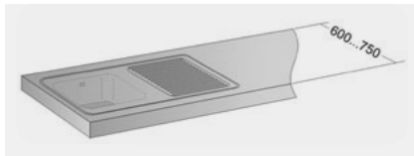

#### 6 SURROUNDING BORDER

Beaded edge  smooth down folded

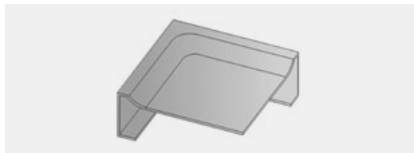

#### 7 UP-FOLDED

Smooth down folded  rear

Height: \_\_\_\_\_ mm

#### 8 WELDED-IN SINK

Smooth welded

Deepened welded

#### 9 SINK SIZE SPECIAL SINK

Only fill out, when a special sink (Part 4) is not required.  
Dimensions in L x W x H mm

A Valve:  right  middle



B Valve:  right  left  middle



C Valve:  right  left  middle

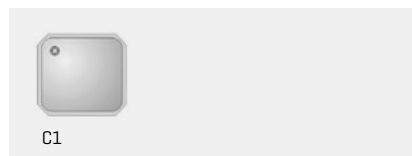

<b>Sink A1</b>	<input type="checkbox"/> 400 x 400 x 300
<input type="checkbox"/> 500 x 300 x 150	<input type="checkbox"/> 450 x 450 x 250
<b>Sink A2</b>	<input type="checkbox"/> 500 x 500 x 250
<input type="checkbox"/> 400 x 400 x 250	<input type="checkbox"/> 500 x 500 x 300
<b>Sink A3</b>	<input type="checkbox"/> 500 x 500 x 350
<input type="checkbox"/> 370 x 370 x 160	<input type="checkbox"/> 600 x 600 x 300
<input type="checkbox"/> 400 x 400 x 200	<input type="checkbox"/> 700 x 700 x 350
<input type="checkbox"/> 400 x 400 x 250	

<b>Sink B1</b>	<input type="checkbox"/> 500 x 400 x 250
<input type="checkbox"/> 240 x 340 x 160	<input type="checkbox"/> 500 x 400 x 350
<b>Sink B2</b>	<input type="checkbox"/> 600 x 500 x 300
<input type="checkbox"/> 200 x 400 x 170	<input type="checkbox"/> 600 x 450 x 300
<input type="checkbox"/> 300 x 500 x 300	<input type="checkbox"/> 600 x 450 x 350
<input type="checkbox"/> 240 x 370 x 150	<input type="checkbox"/> 700 x 500 x 300
<b>Sink B3</b>	<input type="checkbox"/> 700 x 500 x 350
<input type="checkbox"/> 500 x 400 x 200	<input type="checkbox"/> 700 x 600 x 350

<b>Sink C1</b>	<input type="checkbox"/> 340 x 370 x 150
----------------	--

#### 10 OPTIONS

Siphon [all sinks with standing pipe valve]

Tap hole Ø: \_\_\_\_\_ mm (with valve on-site) Drill:  left  middle  right

Standard feet with leveling [±15 mm]  Leveling Ø: \_\_\_\_\_ mm

2 steering castors with brake, 2 fixed castors Ø 125mm

Polyamide steering castors  rubber castors (without trace)

Required castor Ø: \_\_\_\_\_ mm

Legs indented (groove?)  rear: \_\_\_\_\_ mm  side: \_\_\_\_\_ mm

Remarks: \_\_\_\_\_

**TYPE TT 28-26**

# Push-through dishwasher

STAINLESS STEEL 1.4301



- Completely double-walled cover type dishwashing machine\*
- Rinse capacity: Euro norm size, plates or GN 1/1
- Electronic control with thermal stop & brine filtering
- Incl. 1 plate basket (max. Ø 440 mm), 1 glass basket, 1 cutlery basket
- Separate stainless steel wash and clear rinsing arms
- Electronically controlled dosing pump for detergent and rinse agent
- Output: approx. 60 baskets per hour
- Installation also possible over the corner without additional parts!

\* We manufacture infeed and outfeed tables according to your requirements on request!

TYPE	HEAT RECOVERY	DIMENSIONS W x D x H in mm	ARTICLE NO.
Top Tech 28-26	No	700 x 840 x 1570	11.10.02.08
Top Tech 28-26 NRG	Yes	700 x 840 x 2260	11.10.02.09

**TECHNICAL DATA**

Mains supply	400 V; 50/60 Hz
Connected load	11 kW
Water	3/4"
Drain	2"

Dishwashers for gastronomic operations and industrial kitchens

**TYPE TT 32-23 D.7**

# Appliance dishwasher

STAINLESS STEEL 1.4301



- Front door washing machine for rack size 132 x 70 cm, max. insertion height 85 cm
- Ideal for patisseries, butcher's shops, bakeries and Catering establishments 2 versions: with or without heat recovery system
- Operation via 4 soft-touch buttons
- Colour LCD display
- Graphic programming progress display
- USB interfaces on the main and display board
- [enables simple software update]
- Self-cleaning programme
- Special programme for dried dishes
- Double-walled housing incl. door
- Dosage hose pumps for detergent and rinse agent
- Incl. inlet and drain hose
- Built-in drain pump
- Incl. 1 stainless steel basket
- Rinse tank filter, separate spray arms for rinsing

02

TYPE	VERSION	INSERTION HEIGHT maximum	DIMENSIONS W x D x H in mm	ARTICLE NO.
Top Tech 32-23 D.7	Without heat recovery	850 mm	1470 x 850 x 1959	11.10.02.29
Top Tech 32-23 D.7 NRG	With heat recovery	850 mm	1470 x 850 x 2187	11.10.02.31

**TECHNICAL DATA**

Mains supply	3x 400 V; N/PE; 50 Hz; 32 A
Power	15.9 kW
Water consumption	7 l/basket
Heater	Boiler: 10.5 kW, Tank: 10.5 kW
Tank content	131 ltr.
Washing pump	2x 2.7 kW
Rinse pump	2x 0.2 kW [rinse pump]
Basket size	1,320 x 700 mm
Max. Power	30 baskets/h
Boiler content	17 ltr.
Packaging gross weight	approx. 350 Kg
Packaging dimensions [W x D x H]	1750 x 1100 x 2200 mm
Packaging volume	3.50 m <sup>3</sup>

**OPTIONS**

Water softening Double 20	Article no. 11.10.03.51
Commissioning & Instruction	Article no. 99.99.99.97
Bypass for Double 20	Article no. 11.10.03.52
Suction lance with ball check valve	Article no. 11.10.03.53
Stainless steel insert for GN 1/1, 100, 150, 200 mm	Article no. 11.10.03.54
Stainless steel insert for GN 1/1, 100 mm	Article no. 11.10.03.55
Maintenance contract on request	on request

**TYPE TT 32-23 D.6**

# Appliance dishwasher

STAINLESS STEEL 1.4301



- Front door washing machine for rack size 70 x 70 cm, max. insertion height 85 cm.
- Ideal for patisseries, butcher's shops, bakeries and Catering establishments
- 2 versions: With or without heat recovery system
- Operation via 4 soft-touch buttons
- Colour LCD display
- Graphic programming progress display
- USB interfaces on the main and display board [enables simple software update]
- Self-cleaning programme
- Special programme for dried dishes
- Double-walled housing incl. door
- Dosage hose pumps for detergent and rinse agent
- Incl. inlet and drain hose
- Built-in drain pump
- Incl. 1 stainless steel basket
- Rinse tank filter, separate spray arms for rinsing

TYPE	VERSION	INSERTION HEIGHT maximum	DIMENSIONS W x D x H in mm	ARTICLE NO.
Top Tech 32-23 D.6	Without heat recovery	850 mm	853 x 857 x 1960	11.10.02.45
Top Tech 32-23 D.6 NRG	With heat recovery	850 mm	853 x 857 x 2187	11.10.02.46

**OPTIONS**

Water softening Double 20	Article no. 11.10.03.51
Commissioning & Instruction	Article no. 99.99.99.97
Bypass for Double 20	Article no. 11.10.03.52
Suction lance with ball check valve	Article no. 11.10.03.53
Stainless steel insert for GN 1/1, 100, 150, 200 mm	Article no. 11.10.03.54
Stainless steel insert for GN 1/1, 100 mm	Article no. 11.10.03.55
Maintenance contract	on request

**TECHNICAL DATA**

Mains supply	3x 400 V; N/PE; 50 Hz; 32 A
Power	18.7 kW
Water consumption	7 l/basket
Heater	Boiler 8 kW, Tank 8 kW
Tank content	68 ltr.
Washing pump	2.7 kW
Rinse pump	0.2 kW
Basket size	700 x 700 mm
Max. Power	30 baskets/h
Boiler content	12 ltr.
Packaging gross weight	approx. 195 Kg
Packaging dimensions [W x D x H]	950 x 960 x 2,100 mm
Packaging volume	1.72 m³



**TYPE TT 32-23 D.5**

# Appliance dishwasher

STAINLESS STEEL 1.4301



- Front door washing machine for rack size 56 x 63 cm  
Insertion height max. 85 cm
- For washing utensils, trays, pots and trays
- 2 versions: With or without heat recovery system
- Operation via 4 soft-touch buttons
- Colour LCD display
- Graphic programming progress display
- USB interfaces on the main and display board  
[enables simple software update]
- Self-cleaning programme
- Special programme for dried dishes
- Double-walled housing incl. door
- Dosage hose pumps for detergent and rinse agent
- Incl. inlet and drain hose
- Built-in drain pump
- Incl. 1 stainless steel basket 550 x 610 mm
- Rinse tank filter, separate spray arms for rinsing

02

TYPE	VERSION	INSERTION HEIGHT maximum	DIMENSIONS W x D x H in mm	ARTICLE NO.
Top Tech 32-23 D.5	Without heat recovery	850 mm	719 x 782 x 1930	11.10.02.47
Top Tech 32-23 D.5 NRG	With heat recovery	850 mm	719 x 782 x 2156	11.10.02.48

**OPTIONS**

Water softening Double 20	Article no. 11.10.03.51
Commissioning & Instruction	Article no. 99.99.99.97
Bypass for Double 20	Article no. 11.10.03.52
Suction lance with ball check valve	Article no. 11.10.03.53
Stainless steel insert for GN 1/1, 100, 150, 200 mm	Article no. 11.10.03.54
Stainless steel insert for GN 1/1, 100 mm	Article no. 11.10.03.55
Maintenance contract on request	on request

**TECHNICAL DATA**

Mains supply	3x 400 V; N/PE; 50 Hz; 20 A
Power	10.5 kW
Water consumption	7 l/basket
Heater	Boiler 6 kW, Tank 3 kW
Tank content	37 ltr.
Washing pump	1.5 kW
Rinse pump	0.2 kW
Basket size	560 x 630 mm
Max. Power	30 baskets/h
Boiler content	12 ltr.
Packaging gross weight	approx. 185 Kg
Packaging dimensions [W x D x H]	900 x 900 x 2,000 mm
Packaging volume	1.55 m <sup>3</sup>

**TYPE TT 32-23 D.4**

## Appliance dishwasher

---



- Universal dishwasher with front loading for basket size 56 x 63 cm
- Maximum insertion height: 650 mm
- 2 versions: With or without heat recovery system
- Operation via 4 soft-touch buttons
- Colour LCD display
- Graphic programming progress display
- USB interfaces on the main and display board
- [enables simple software update]
- Self-cleaning programme
- Special programme for dried dishes
- Double-walled housing incl. door
- Dosage hose pumps for detergent and rinse agent
- Incl. inlet and drain hose
- Built-in drain pump
- Incl. 1 stainless steel basket 550 x 610 mm
- Rinse tank filter, separate spray arms for rinsing

**TECHNICAL DATA**

Mains supply	3x 400 V; N/PE; 50 Hz; 20 A
Power	10.5 kW
Water consumption	7 l/basket
Heater	Boiler 6 kW, Tank 3 kW
Tank content	37 ltr.
Washing pump	1.5 kW
Rinse pump	0.2 kW
Basket size	560 x 630 mm
Max. Power	30 baskets/h
Boiler content	12 ltr.
Packaging gross weight	approx. 160 Kg
Packaging dimensions [W x D x H]	900 x 900 x 2,000 mm
Packaging volume	1.55 m <sup>3</sup>

TYPE	VERSION	INSERTION HEIGHT maximum	DIMENSIONS W x D x H in mm	ARTICLE NO.
Top Tech 32-23 D.4	Without heat recovery	650 mm	719 x 782 x 1727	11.10.01.90
Top Tech 32-23 D.4 NRG	With heat recovery	650 mm	719 x 782 x 1956	11.10.01.91

**OPTIONS**

Water softening Double 20	Article no. 11.10.03.51
Commissioning & Instruction	Article no. 99.99.99.97
Bypass for Double 20	Article no. 11.10.03.52
Suction lance with ball check valve	Article no. 11.10.03.53
Stainless steel insert for GN 1/1, 100, 150, 200 mm	Article no. 11.10.03.54
Stainless steel insert for GN 1/1, 100 mm	Article no. 11.10.03.55
Maintenance contract on request	on request





**MOHN**<sup>®</sup>  
www.mohn-gmbh.com

**TYPE HWA-HIGHLINE**

# Cover-type washing system

STAINLESS STEEL 1.4301



Industry:  
Dishwasher with front loading  
for highest demands!

Dishwasher with front loading for generally heavily polluted items to be washed and highest demands. Basket size: 1,300 x 700 mm, max. rack height: 650 mm. Suitable for the following items to be washed:

- Boxes, baskets and GN containers
- Coarse dishes und machine parts
- Boilers, buckets and trolleys
- Thermal tanks/ Thermal ports
- Baking trays, trays and tins
- Knife baskets

TYPE	POWER/HOUR	DIMENSIONS W x D x H in mm	ARTICLE NO.
HWA-H	10 - 30 batches	1550 x 1300 x 2100	11.10.02.20

**TECHNICAL DATA**

Mains supply	3~ 400 V; 50 Hz; 6 - 26 kW*
Fresh water connection	G 3/4"; 2 - 5 bar; 2 - 6 °dH; approx. 10 - 85 °C
Drain	DN50
Washing pump	4.00 kW; 1,500 l/min; approx. 1.50 bar +/- 0.5 bar
Clear rinsing washing pump	0.75 kW
Washing arms drive	0.12 kW
Weight	approx. 700 kg (empty weight), approx. 1,000 kg (filled)

\*dependent on the fresh water supply temperature

**DESCRIPTION**

- Reliable cleaning of boxes and utensils from various fields of the food industry
- First-class washing results in spite of the universal usability
- Simple operation due to two-door system and one-button start with preselection of 2 wash programs
- Wash programmes can be set, e.g. 2/6 minutes
- Equipped with innovative washing system: Washing arms do not rotate, but move in a pivoting way. Advantage: also remote corners of the washing areal are reached
- Washing arms with own drive, advantage: No loss of washing power, water pressure can be used unlimited for cleaning
- A clear rinsing pump is mounted in the clear rinsing line in order to increase the pressure for clear rinsing so that it is ensured that the clear rinsing arms rotate
- Very stable and fully welded machine housing, particularly suitable for permanent use
- Powerful 4 kW EDUR wash pump, high water circulation 1,500 l/min. at 1.5 bar wash pressure
- 300 ltr. Tank volume
- Low energy consumption due to double-walled housing
- Easy cleaning of the system due to smooth external surfaces and an external box filter
- Electrical heating with special spiral heaters, easy to clean and secure against burn-through
- 10 kW heating power in the tank, electrical flange radiator
- 10 kW heating power of clear rinsing boiler, electrical flange radiator
- Tank heating can optionally take place using steam or hot water
- Fresh water consumption approx. 15 to 20 l/batch

**OPTIONS**

Suction: At the end of the programme, the water vapour can be extracted from the machine via a stainless steel suction fan, connection DN 250, Adjustable fan running time	Article no. 11.10.02.74
Tank heater with direct steam	Article no. 11.10.02.75
Increase in usable height from 650 to 850 mm	Article no. 11.10.12.22

**TYPE DWA-HIGHLINE**

**Rotating basket washing system** for customer-specific items to be washed







Universal dishwasher for highest demands and customer-specific items to be washed, such as:

- Shapes
- Containers, boxes and baskets
- GN Container
- Multi-head weighing hopper
- Knife baskets

Universal dishwasher with cover opening for generally heavily polluted items to be washed and highest demands.  
Basket diameter: 1,080 mm, max. loading height: 850 mm,  
Useable height: 650 mm.

Suitable for cleaning customer-specific items to be washed

- Containers, boxes and baskets
- GN Container
- Knife baskets
- Shapes
- Multi-head weighing hopper

TYPE	POWER/HOUR	DIMENSIONS W x D x H in mm	ARTICLE NO.
DWA-H	10 - 12 batches	1500 x 1800 x 1500	11.10.02.21

**TECHNICAL DATA**

Mains supply	3~ 400 V; 50 Hz; approx. 24 kW; 32 A
Fresh water connection	3/4"; 2 to 6 bar
Drain	DN50
Exhaust air	DN 250

**DESCRIPTION**

The machine is equipped with a washing, spinning drying and optionally with a blow off. The receptacle basket is manufactured to be suitable for your items to be washed [container etc.].

The system is therefore best suitable for cleaning customer-specific, different items to be washed. The strong stainless steel centrifugal pump with an output of 3.0 kW and a circulation of 900 l/min at 1.5 bar pressure enables optimal cleaning results at short batch times.

- Stable machine housing made of one piece and completely welded, low energy consumption
- Fully welded washing basket made of 8 to 10 mm round steel, Diameter: 1,080 mm, stable also with high point and shock loads
- Electrical heating with special spiral heaters, easy to clean and secure against burn-through
- Cover with weight relief, for easy operation
- Intelligent filter system for continuous cleaning of suds in the tank
- Washing performance: 10 - 12 batches [approx. 60 E2 containers] per hour, Batch time approx. 3 - 5 minutes
- Washing basket at the end of program, thereby only little residual moisture when removing the basket. The drying result can be further improved due to the optional blow down

**OPTIONS**

Blow down with a 4.0 kW strong ELEKTOR high-pressure compressor	Article no. 11.10.02.22
Insulation coating in the lower area [sides and bottom]	Article no. 11.10.02.23
Clear rinsing via separate nozzle pipes	Article no. 11.10.02.24
Washing system on 4 heavy-duty rollers	Article no. 11.10.02.25

**TYPE RSW**

## Smoke stick washing system

---



Type RSW-I with opened cover



High-quality control cabinet components

- Drum diameter 600 mm [RSW-I] or 800 mm [RSW-II],
- Suitable for 300 - 500 [RSW-I] or 400 - 600 [RSW-II] Smoke sticks per batch
- With stable worm- and helical-gear motor 0.75 kW [RSW-I] or 1.5 kW [RSW-II] make: Getriebebau Nord, via frequency converter infinitely adjustable, adjustment in the control cabinet.
- Drum direct drive via low-maintenance offset geared motor, very stable and durable double-sided drum bearing
- At the end of the program, the drum stands with the flap opening being at the top
- On the whole, very stable version, the drum is made from 4 mm thick perforated plate and provided with very stable locking devices.
- Cover made of 2 mm thick stainless steel sheet with gas pressure absorbers and safety switch which stops the drive motor when opening
- Control takes place via a SIEMENS Logo SPS

**OPTIONS**

Heater with direct steam incl. Nivelco float	Article no. 49.90.00.90
Heating with 10 kW electricity at fresh water 30 - 55 °C	Article no. 49.90.00.91
Heating with 20 kW electricity at fresh water 5 - 29 °C	Article no. 49.90.00.92

TYPE	CAPACITY Smoke sticks	DIMENSIONS W x D x H in mm	ARTICLE NO.
RSW-I	300 - 500 pieces	1860 x 1050 x 1350	49.90.00.07
RSW-II	400 - 600 pieces	1860 x 1350 x 1550	49.90.01.07
RSW-I-DW*	300 - 500 pieces	2100 x 1000 x 1260	49.90.00.10
RSW-II-DW*	400 - 600 pieces	2100 x 1000 x 1260	49.90.01.17

\*DW = double-walled

**OPERATING PROCESS**

Open flap and drum, close drain cock Insert smoke sticks (max. 2/3 filling of the drum), add detergent, Close drum and unit, program sequence starts:

- Filling with warm water
- Drum rotates
- Water filling continues, amount is adjusted via a controller on the unit
- Washing liquid flows via a wide outlet through a filter bucket downward into a floor drain provided by the customer [continuous dirt removal from the surface]
- Tank empties via foot-operated ball valve, drum rotates further for rinsing via nozzles that rinse the smoke sticks through the drum holes and final drying
- Programme end is signalled visually

Smoke sticks can be removed [Drum drives to correct position for removal]

**TECHNICAL DATA**

Inner drum length	1,100 mm
Feeding height	700 mm
Program duration	30 - 60 minutes
Water connection	G 3/4"; 2 - 5 bar; 2 - 6 °dH; 10 - 80 °C
Water drain	DN 50
Fresh water temperature	min. 55 °C [without additional heating]
Steam connection	V-flange 3/4"; DN 20; Ø 26.9 mm
Air connection	1/4" sleeve
Mains supply	3~ 400 V; 16 A

**RSW-I**

Smoking sticks/batch	300 - 500 pieces
Power	1.0 kW
Tank content	350 litres
Water consumption/h	500 litres
Drum diameter	600 mm

**RSW-II**

Smoking sticks/batch	400 - 600 pieces
Power	1.75 kW
Tank content	400 litres
Water consumption/h	400 - 500 litres
Drum diameter	800 mm

**TYPE VSW**

## Attachment rails washing system

---





Cleaning drum

**DESCRIPTION**

Our attachment rail washing system enables thorough cleaning of 100 to 500 attachment rails per washing cycle for cut sheets in different lengths. The machine has been especially developed for businesses which have to clean a large number of cut sheets. For residue-free cleaning of your cut sheets, we recommend our pass-through washing system.

- Drum washing system with cover opening
- Capacity: 100 - 500 Attachment rails for cutting plates per batch [depending on the length of the attachment rails]
- Stable machine housing, completely welded, low energy consumption
- Power: 100 - 500 pieces of attachment rails per washing cycle, depending on the relevant size [also with simultaneously different sizes]
- Recommended washing temperature for optimal cleaning results: 55 °C
- 10 kW electrical heating for warming up optionally available

**OPERATING PROCESS**

- Place the machine next to the cake cutter or in the washing chamber
- Open the housing and drum cover
- Insert attachment rails
- Close the housing and drum cover
- Start the cleaning program
- Program sequence takes place automatically [Cleaning time: approx. 40 - 60 minutes]
- Remove clean and almost dry attachment rails [Drum drives to correct position for removal]

**TECHNICAL DATA**

Mains supply	230 V; 50/60 Hz; 1 kW 400 V; 50/60 Hz; 11 kW [with optional 10 kW heating]
Fresh water connection	1/2"; min. 55 °C
Drain	DN 50
Water consumption	160 litres/wash cycle

TYPE	POWER/CHARGE*	DIMENSIONS W x D x H in mm	ARTICLE NO.
VSW	100 - 500 pieces	700 x 500 x ~1150	49.90.00.09

*\*Depending on the rail length [per washing cycle]*

**OPTIONS**

Heating with 10 kW power [with cold water connection]	Article no. 49.90.00.93
---	-------------------------

The washing system has been especially developed for businesses which have to clean a large number of cut sheets!



**TYPE DLWA 180 ECOLINE**

# Pass-through washing system for boxes

STAINLESS STEEL 1.4301



**DLWA 180 ECOLINE**

- Recommended washing temperature 40 - 45 °C
- Tank: 10 kW heating power
- Final rinsing using integrated boiler: 10 kW Power [For heating and thermal disinfection at +82 °C]
- Water inlet temperature required on site: > 40 °C

**DLWA 180 BACK ECOLINE**

- Recommended washing temperature 55 - 60 °C
- Tank: 20 kW heating power
- Final rinsing using fresh water, temperature depending on the water supply temperature to be provided by the customer, no heating!

**OPTIONS**

Frequency converter to control the throughput speed	Article no. 20.00.00.92
Wire basket for cleaning small parts	Article no. 20.00.00.91
Outlet roller conveyor, straight, 1,000 mm	Article no. 20.00.00.93
Outlet roller conveyor, 90° curve	Article no. 20.00.00.94
Outlet roller conveyor, 180° curve	Article no. 20.00.00.95

TYPE	POWER	DIMENSIONS W* x D x H in mm	ARTICLE NO.
DLWA-180	24 kW	3000 x 820 x 1500	11.10.00.40
DLWA 180 BACK	24 kW	3000 x 820 x 1500	11.10.00.41

\*Including infeed and outfeed table [500 mm each]

The system consists of the main wash zone and a separate final rinse zone on a length of 2,000 mm. Using it, slightly to medium polluted Euro containers (E1 to E3) can be cleaned quickly and effectively.

- Completely welded housing, exclusively made of stainless steel
- To a large extent, support manufactured of 3 mm metal sheet, therefore very durable
- Main washing zone with a strong centrifugal pump, output 2.2 kW, circulation 800 l/min at a wash pressure of 1 bar, distributed to 60 stainless steel nozzles
- Plate filter for constant cleaning and continuous filtering of the sud
- Box transport by means of stable stainless steel spiral [utility model]
- Precise crate separation and area-wide distribution of the wash suds from the underside
- Box inclination for improved cleaning of all sides
- System on M16 machine feet or stainless steel rollers [optionally]
- Adjustable box turner for one-person operation
- Inclination on the outlet side for returning water on the bottom of the box

**TECHNICAL DATA**

Mains supply	3x 400 V; N/PE; 50 Hz
Connected load	24 kW
Pump performance	2.2 kW; 800 l/min at 1 bar
Water connection	3/4"; min. 40 °C; 1 - 6 bar
Water drain	DN 50 [tank overflow]
Water consumption	approx. 300 l/h [constant]
Tank volume	280 l
Tank heater	10 kW [DLWA 180], 20 kW [DLWA 180 BACK]
Feeding height	900 mm
Washing tunnel dimensions	W: 630 x H: 430 mm [adjustable]
Washing tunnel length	2,000 mm
Items to be washed	Euro containers [E1 to E3]
Power	approx. 180 E-containers per hour



1 DLWA 180 Ecoline

2 Box transport by means of stainless steel spiral



**TYPE DLWA 300 ECOLINE**

# Pass-through washing system for boxes

STAINLESS STEEL 1.4301



**DLWA 300 ECOLINE**

- Recommended washing temperature 40 - 45 °C
- Tank: 20 kW heating power
- Final rinsing using integrated boiler: 10 kW Power [For heating and thermal disinfection at +82 °C]
- Water inlet temperature required on site: > 40 °C

**DLWA 300 BACK ECOLINE**

- Recommended washing temperature 55 - 60 °C
- Tank: 30 kW heating power
- Final rinsing using fresh water, temperature depending on the water supply temperature to be provided by the customer, no heating!

**OPTIONS**

Frequency converter to control the throughput speed	Article no. 20.00.00.92
Wire basket for cleaning small parts	Article no. 20.00.00.91
Outlet roller conveyor, straight, 1,000 mm	Article no. 20.00.00.93
Outlet roller conveyor, 90° curve	Article no. 20.00.00.94
Outlet roller conveyor, 180° curve	Article no. 20.00.00.95

TYPE	POWER	DIMENSIONS W* x D x H in mm	ARTICLE NO.
DLWA-300	35 kW	4000 x 820 x 1500	11.10.00.42
DLWA 300 BACK	35 kW	4000 x 820 x 1500	11.10.00.43

\*Including infeed and outfeed table [500 mm each]

The system consists of the main wash zone and a separate final rinse zone on a length of 3,000 mm. Using it, slightly to medium polluted Euro containers (E1 to E3) can be cleaned quickly and effectively.

- Completely welded housing, exclusively made of stainless steel
- To a large extent, support manufactured of 3 mm metal sheet, therefore very durable
- Main washing zone with a strong centrifugal pump, output 4.5 kW, Circulation 1,400 l/min at a wash pressure of 1 bar, distributed to 80 stainless steel nozzles
- Plate filter for constant cleaning and continuous filtering of the sud
- Box transport by means of stable stainless steel spiral [utility model]
- Precise crate separation and area-wide distribution of the wash suds from the underside
- Box inclination for improved cleaning of all sides
- System on M16 machine feet or stainless steel rollers [optionally]
- Adjustable box turner for one-person operation
- Inclination on the outlet side for returning water on the bottom of the box

**TECHNICAL DATA**

Mains supply	3x 400 V; N/PE; 50 Hz
Connected load	35 kW
Pump performance	4.5 kW; 1,400 l/min at 1 bar
Water connection	3/4"; min. 40 °C; 1 - 6 bar
Water drain	DN 50 [tank overflow]
Water consumption	approx. 400 l/h [constant]
Tank volume	400 litres
Tank heater	20 kW [DLWA 300], 30 kW [DLWA 300 BACK]
Feeding height	900 mm
Washing tunnel dimensions	W: 630 x H: 430 mm [adjustable]
Washing tunnel length	3,000 mm
Items to be washed	Euro containers [E1 to E3]
Power	approx. 300 E-containers per hour



1 DLWA 300 Ecoline

2 Spiral system for box transport

**TYPE DLWA-A 180 ECOLINE**

## Pass-through washing system



Type DLWA-A 180 Ecoline



Type DLWA-A 180 Ecoline, open



Type DLWA-A 180 Ecoline, detail air knife

**FOR CLEANING AND BLOWING OFF 160 EURONORM CONTAINERS (E1 - E3) PER HOUR.**

The compact machine consists of a main wash zone and a rinse zone. Using it, slightly to medium polluted Euronorm containers (E1 to E3) can be cleaned and blowed quickly and effectively. The machine has a one-man operation [crate turner] as standard.

Upon activating the machine via the main switch, the tank will automatically fill up. Upon reaching a tank volume of approximately 360 litres, the water supply ceases, and the water is heated to a temperature of 50 - 55 °C by the integrated 10 kW heater. Once the temperature is reached, you may initiate the washing process by pressing the start button. The dosage of the detergent is carried out via an on-site dosing unit or optionally via an already installed dosing pump [see accessories]. The tank contents are continuously monitored by a float switch.

The boxes are gently inclined and conveyed through the machine via a rotating stainless steel helical spiral. This ensures an optimal distance between each box and, moreover, thanks to its simple construction, easy handling and straightforward cleaning. In the main wash zone, a high-performance centrifugal pump [2.2 kW, 800 l/min at 1 bar], optimally positioned stainless steel nozzles with a large clearance, and an extended contact time of the washing solution ensure an outstanding cleaning result. The wash liquor is filtered through a plate filter and returned to the wash tank.

Following this, a clear rinsing of the containers is carried out using fresh water. The rinse water is fed into the wash tank to refresh the wash liquor. Finally, the boxes pass through the blow-off zone with side channel blowers with an output of 1.1 kW each. The blow-off is carried out by two stainless steel air knives, which are arranged in such a way that they blow off the top and bottom of the crates.

**MACHINE CONNECTIONS**

- Fresh water with min. 40°C 3/4", flow pressure min. 2 max. 5 bar via hose connection, consumption approx. 300 l/h [please note: the machine requires hot fresh water Connection 1/2" or 3/4"]
- Electricity: 24 kW; 400 V; 50Hz
- Waste water pipe DN 50 into a floor drain or trough near the machine below the machine tank with standpipe

Supplied without plug!

**KEY ADVANTAGES OF OUR MACHINE**

- Powerful centrifugal pump [2.2 kW; 800 l/min at 1 bar]
- Robust machine feet or stainless steel castors [please specify in case of order]
- Box turner for one-man operation included
- Inclination on the outlet side for returning water on the bottom of the box
- Completely welded, very sturdy machine housing
- Lower structure largely made of 3 mm stainless steel sheet
- Innovative conveying system via rotating stainless steel deflector, few moving parts, simple and reliable, patent-protected
- Tool-free removable nozzle arms allow for easy cleaning and maintenance
- Stainless steel nozzles with a large orifice provide excellent cleaning performance and are resistant to contamination
- Special helical heaters made from heat-resistant stainless steel, easy to clean and protected against burnout
- Two side channel blowers for blow-off
- All add-on parts used come from renowned manufacturers

**TECHNICAL DATA**

Rated machine power	160 pieces/h (E1 to E3)
Total length	3845 mm
Machine width	905 mm
Machine height	approx. 1,500 mm
Support height	approx. 900 mm
Passage width	up to 630 mm [adjustable]
Passage height washing tunnel	430 mm
Heating power	Heating 10 kW in the tank Boiler for rinsing 10 kW
Pump performance	2.1 kW at 800 l/min circulation, Washing pressure 1 bar
Side channel blower	with 1.2 kW each
Tank content	approx. 360 litres



## Advantages of our pass-through washing systems



Pass-through washing system for boxes Type DLWA Highline

### MOHN PASS-THROUGH WASHING SYSTEMS

#### Tailor-made for practical application

At first glance, the boxes for transport look all the same, but the demands of the users are nowhere near. Particularly with regard to speed and safety during cleaning, the requirements related to the washing system are especially versatile. Installation, operation and maintenance can become a real challenge depending on the available space and environment. Individual solutions based on expert knowledge and technical know how are in demand here as they are provided worldwide by the Mohn GmbH.

Numerous parameters play a key role here. So it is first determined how many containers accrue for cleaning per hour or day. Together with the level of pollution, this is the decisive factor that decides on whether a one-tank or multi-tank system shall be installed.

Last but not least, it shall be possible for the washing system itself to be cleaned easily and quickly. In order to ensure this, Mohn builds the machine housing of one piece and completely welded. The washing tunnels are equipped with a long, active washing zone and additionally double-walled and insulated in 30 mm thickness. This not only contributes to a long service life and a low energy consumption, but also to a reduction of the noise level during the washing process.

Further factors which have an impact in practice include generously sized tanks and strong washing pumps that tackle pollution by means of high circulation and pressure and simultaneously make do with a lower temperature, less detergents and shorter cleaning time. With a large passage, the stainless steel washing nozzles ensure an optimal cleaning performance and are for their part insensitive to contamination due to the self-cleaning effect. A generously built outside box filter ensures the uptake of large amounts of dirt and can be easily cleaned also during running operation.

The designers have managed to create a special technical feature for the construction and arrangement of the nozzle adapters. So with only a few hand movements, the nozzle adapters can be taken out, completely cleaned and merely installed again in the optimal position that has been specified only once. Conclusion: The washing pattern cannot be modified and keeps being effective in the same way.

The slanting passage of the E-boxes is a clever measure against unnecessary water diversion from the washing tunnel. The installation of cold-water pre-jetting is optional in order to avoid coarse dirt or protein entries into the washing tunnel. Insulated blow-off tunnels or innovative centrifugal drying modules are additionally available for best possible and quick drying.



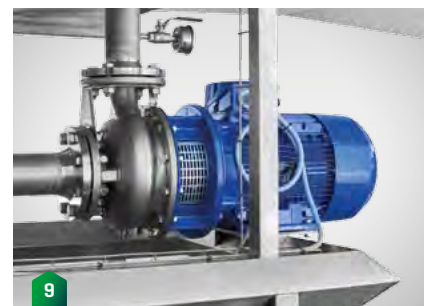

**ADVANTAGE 1**

- Large control cabinet with SIEMENS components

**ADVANTAGE 2**

- Easy cleaning of the filter boxes also possible during running operation
- Large outside box filter for taking up large amounts of dirt

**ADVANTAGE 3**

- Numbered nozzle arms, can be removed and cleaned without tools.
- No adjustment of the cleaning pattern

**ADVANTAGE 4**

- Stainless steel nozzles with large passage for good cleaning effect.
- Insensitive to contamination

**ADVANTAGE 5**

- Optional cold-water pre-cleaning to avoid protein or coarse dirt entry into the washing tunnel

**ADVANTAGE 6**

- 30 mm insulated, double-walled tunnel housing with large maintenance doors for easy interior cleaning

**ADVANTAGE 7**

- Easy height adjustment of the hold-down device to clean differently high items to be washed in a washing tunnel

**ADVANTAGE 8**

- Box slanting passages for less water diversion from the washing tunnel

**ADVANTAGE 9**

- Powerful stainless steel centrifugal pumps with high circulation and high wash pressure

**TYPE DLWA 200 - DLWA 400 HIGHLINE**

**Single tank pass-through washing system for boxes**



DLWA 250 Highline with optional outfeed roller conveyor

**SYSTEM LAYOUT**

- Completely double-walled, soundproof and heat insulated machine housing made of one piece and completely welded, low energy consumption
- Nozzle arms with stainless steel nozzles can be removed and cleaned without any tools (Nozzle arms with forced positioning)
- Infeed table: Length: 1,500 mm
- Longitudinal or transverse through-feed with a Scanbelt bone chain, clearly slanted with Euro containers
- Passage height suitable for Euronorm E1 – E3, adjustable on request for customer-specific items to be washed
- Tunnel pass-through with height adjustment via easily adjustable hold-down devices
- Strong stainless steel centrifugal pump with high circulation and strong wash pressure
- Plate filter that can be removed via the maintenance door, for simple soiling and daily outputs up to 1,000 pieces; External filter tank for taking up larger amounts of dirt, see options
- Electric tank heater: 2x 10 kW; optional with steam directly or via heat exchanger
- Outlet table: Length 1,500 mm with limit switch (Belt + final rinsing stop with full outfeed table)
- Optionally with blow-off tunnel in different performance levels, depending on desired blow-off result

**OPTIONS**

External filter tank	Article no. 11.10.00.87
Fresh water pre-injection < 45 °C inlet temp.	Article no. 11.10.00.69
Fresh water pre-injection > 50 °C Inlet temp.	Article no. 11.10.00.68
Vapour extraction with piping	Article no. 11.10.00.81
Waste water heat exchanger for fresh water heating	Article no. 11.10.02.80
Tank heater with direct steam	Article no. 11.10.00.84
Steam heat exchanger wash tank	Article no. 11.10.00.83
Hot water or thermal oil heat exchanger for wash tank	Article no. 11.10.02.81
Rinsing boiler, 1x 10 kW	Article no. 11.10.00.86
Rinsing boiler, 2x 10 kW	Article no. 11.10.00.85
Steam heat exchanger final rinsing	Article no. 11.10.00.82
Blow-off DLWA-BS-1, 1 fan with 5.5 kW, length: 2,300 mm	Article no. 11.10.00.89
Blow-off DLWA-BS-2, 2 fans 5.5 kW each, length: 2,300 mm	Article no. 11.10.00.88
Box turner DLWA + blow-off unit	Article no. 11.10.00.78
Box turner DLWA	Article no. 11.10.00.80





Detail: Box slanting passage

	TYPE DLWA 200	TYPE DLWA 250	TYPE DLWA 300	TYPE DLWA 400
<b>BOXES/H</b>	200 - 250	250 - 300	300 - 350	350 - 400
<b>TANK VOLUME</b> with plate filter	300 l	300 l	400 l	400 l
<b>TANK VOLUME</b> with outside box filter	400 l	400 l	450 l	450 l
<b>TANK VOLUME</b> with drum filter	600 l	600 l	600 l	600 l
<b>MAIN WASH ZONE</b> in mm	L: 1800	L: 1800	L: 2700	L: 2700
<b>PUMP</b> Main wash zone	4.0 kW; 1,000 l/m 2 bar	7.5 kW; 1,000 l/m; 3 bar	7.5 kW; 1,000 l/m; 3 bar	11 kW; 1,000 l/m; 5 bar
<b>HEATING CAPACITY MAIN WASH TANK</b> in kW	20	20	20	20
<b>TOTAL LENGTH</b> in mm	4800	4800	5700	5700
<b>ARTICLE NO.</b>	11.10.01.20	11.10.00.44	11.10.01.21	11.10.00.46

**TECHNICAL DATA**

Mains supply	3x 400 V; N/PE; 50 Hz
Connected load	28 kW [DLWA 250], 32 kW [DLWA 400]
Water connection	3/4"; 15 - 85 °C; 2 - 6 bar; 2 - 8 °dH
Water drain	DN 50
Exhaust air socket	DN 250
Water consumption	approx. 300 - 400 l/h depending on model
Tank heater	2x 10 kW
Feeding height	950 mm
Washing tunnel dimensions	W: 610 x H: 410 mm
Washing tunnel length	1,800 mm [DLWA 200 + 250] 2,700 mm [DLWA 300 + 400]

**TYPE DLWA 400-2T - DLWA 1000-3T HIGHLINE**

**Multi tank pass-through washing system for boxes**



DLWA Highline

**SYSTEM LAYOUT**

- Completely double-walled, soundproof and heat insulated machine housing made of one piece and completely welded, low energy consumption
- Pre-wash zone
- Nozzle arms with stainless steel nozzles can be removed and cleaned without any tools (Nozzle arms with forced positioning)
- Infeed table: Length: 1,500 mm
- Longitudinal or transverse through-feed with a Scanbelt bone chain, clearly slanted with Euro containers
- Passage height suitable for Euronorm E1 - E3, adjustable on request
- Tunnel pass-through with height adjustment via easily adjustable hold-down devices
- Strong stainless steel centrifugal pump with high circulation and strong wash pressure
- Plate filter that can be removed via the maintenance door, for simple soiling and daily outputs up to 1,000 pieces; External filter tank for taking up larger amounts of dirt, see options
- Electric tank heater: optional with steam directly or via heat exchanger
- Outlet table: Length 1,500 mm with limit switch (Belt + final rinsing stop with full outfeed table)
- Optionally with blow-off tunnel in different performance levels, depending on desired blow-off result

**OPTIONS**

External filter tank	Article no. 11.10.00.87
Drum filter at a 90° angle to the machine	Article no. 11.10.01.34
Fresh water pre-injection < 45 °C inlet temp.	Article no. 11.10.00.69
Fresh water pre-injection > 50 °C Inlet temp.	Article no. 11.10.00.68
Vapour extraction or piping [2x required]	Article no. 11.10.02.74
Waste water heat exchanger for fresh water heating	Article no. 11.10.02.80
Tank heater with direct steam	Article no. 11.10.00.84
Steam heat exchanger wash tank	Article no. 11.10.00.83
Hot water or thermal oil heat exchanger for wash tank	Article no. 11.10.02.81
Rinsing boiler, 1x 10 kW	Article no. 11.10.00.86
Rinsing boiler, 2x 10 kW	Article no. 11.10.00.85
Steam heat exchanger final rinsing	Article no. 11.10.00.82
Blow-off DLWA-BS-1, 1 fan with 5.5 kW, length: 2,300 mm	Article no. 11.10.00.89
Blow-off DLWA-BS-2, 2 fans 5.5 kW each, length: 2,300 mm	Article no. 11.10.00.88
Blow-off DLWA-BS-3, 3 fans á 5.5kW, length 3,700 mm	Article no. 11.10.01.32
Blow-off DLWA-BS-4, 4 Fans 5.5 kW each, length: 4,100 mm	Article no. 11.10.01.33

	TYPE DLWA 400-2T	TYPE DLWA 500-2T	TYPE DLWA 600-2T	TYPE DLWA 800-2T
<b>BOXES/H</b>	400 - 500	400 - 600	500 - 700	600 - 900
<b>PREWASH</b> in mm	L: 1800	L: 1800	L: 2700	L: 3600
<b>PUMP</b> Prewash	4 kW; 1,200 l/m; 1.5 bar	4 kW; 1,200 l/m; 1.5 bar	4 kW; 1,200 l/m; 1.5 bar	4 kW; 1,200 l/m; 1.5 bar
<b>TANK VOLUME</b> with plate filter	300 l	-	-	-
<b>TANK VOLUME</b> with outside box filter	450 l	450 l	550 l	550 l
<b>TANK VOLUME</b> with drum filter	600 l	600 l	600 l	800 l
<b>MAIN WASH ZONE</b> in mm	L: 1800	L: 2700	L: 2700	L: 2700
<b>PUMP</b> Main wash zone	7.5 kW; 1,000 l/m; 3 bar	7.5 kW; 1,000 l/m; 3 bar	7.5 kW; 1,000 l/m; 3 bar	7.5 kW; 1,000 l/m; 3 bar
<b>HEATING CAPACITY MAIN WASH TANK</b> in kW	30	30	30	30
<b>TANK VOLUME</b> with outside box filter	500 l	500 l	600 l	600 l
<b>TANK VOLUME</b> with drum filter	700 l	700 l	700 l	700 l
<b>TOTAL LENGTH</b> in mm	6600	7500	8400	9300
<b>ARTICLE NO.</b>	11.10.01.22	11.10.01.23	11.10.01.24	11.10.01.25

	TYPE DLWA 1000-3T
<b>BOXES/H</b>	800 - 1200
<b>PREWASH</b> in mm	L: 3600
<b>PUMP</b> Prewash	4 kW; 1,200 l/m; 1.5 bar
<b>TANK VOLUME</b> with outside box filter	800 l
<b>TANK VOLUME</b> with drum filter	1,000 l
<b>MAIN WASH ZONE</b> in mm	L: 2700
<b>PUMP</b> Main wash zone	11 kW; 1,000 l/m; 5 bar
<b>HEATING CAPACITY MAIN WASH TANK</b> in kW	40
<b>TANK VOLUME</b> with outside box filter	800 l
<b>TANK VOLUME</b> with drum filter	800 l
<b>SEPARATE RINSING ZONE</b> in mm	L: 2700
<b>PUMP</b> Rinsing zone	1.5 kW; 500 l/m; 1.5 bar
<b>TANK VOLUME</b> with plate filter	300 l
<b>TANK VOLUME</b> with outside box filter	400 l
<b>TOTAL LENGTH</b> in mm	12000
<b>ARTICLE NO.</b>	11.10.01.26

Higher hourly outputs possible on request!

**TECHNICAL DATA**

Mains supply	3x 400 V; N/PE; 50 Hz
Water connection	3/4"; 15 - 85 °C; 2 - 6 bar; 2 - 8 °dH
Water drain	DN 50
Exhaust air socket	DN 250
Water consumption	approx. 400 - 600 l/h depending on model
Feeding height	950 mm
Washing tunnel dimensions	W: 610 x H: 410 mm

**TYPE DLWA 250, 400-BACK HIGHLINE**

**Pass-through washing system for boxes & baking trays**



DLWA 250-BACK Highline, incl. blow off BS-2

This washing system has been especially developed for bakeries and can be universally used for different items to be washed such as baking trays, baskets and so on. The trays run longitudinally through the machine and are fixed by easily adjustable, lateral hold down devices. Baskets are conveyed longitudinally or diagonally through the machine.

**SYSTEM LAYOUT**

- Version as described on page 130 but with the following deviations
- Washing temperature approx. 55°C
- **DLWA 250-BACK Highline:** Stainless steel centrifugal pump with 4 kW Capacity at 1,000 l/min circulation and 2 bar washing pressure, distributed on 50 stainless steel flat spray nozzles
- **DLWA 400-BACK Highline:** Stainless steel centrifugal pump with 5.5 kW Capacity at 1,400 l/min circulation and 2 bar washing pressure, distributed on 70 stainless steel flat spray nozzles
- Integrated large external filter tank for taking up larger amounts of dirt
- Electric tank heater: 2x 10 kW (DLWA-400-BACK: 3x 10 kW); optional with steam directly or via heat exchanger
- Optionally with blow-off tunnel in different performance levels, depending on desired blow-off result

**DLWA 250-BACK HIGHLINE**

Capacity 250 boxes/h (60/40) or 100 - 150 trays/h (58/78 or 60/90)

**DLWA 400-BACK HIGHLINE**

Capacity 400 boxes/h (60/40) or 250 - 300 trays/h (58/78 or 60/90)

TYPE	POWER	DIMENSIONS* W x D x H in mm	ARTICLE NO.
DLWA-250 BACK	26 kW	4800 x 1300 x 1580	11.10.00.45
DLWA-400 BACK	39 kW	5700 x 1300 x 1580	11.10.00.47

*\*incl. external filter tank*



## Our all-rounder for bakeries!

The washing system can be universally used for different items to be washed [boxes and baking trays].

02

### OPTIONS

Fresh water pre-spraying DLWA 250/400 at water supply temperatures less than 45 °C	Article no. 11.10.00.69
Fresh water pre-spraying DLWA 250/400 at water supply temperatures larger than 50 °C	Article no. 11.10.00.68
Box turner / one-person operation for DLWA 250	Article no. 11.10.00.80
Box turner / one-person operation for DLWA 400	Article no. 11.10.00.79
Vapour exhaust DN 250, 1,500 m <sup>3</sup> /h at 500 Pa	Article no. 11.10.00.81
Tank heater with direct steam	Article no. 11.10.00.84
Tank heater with indirect steam	Article no. 11.10.00.83
Rinsing boiler, 1x 10 kW	Article no. 11.10.00.86
Rinsing boiler, 2x 10 kW	Article no. 11.10.00.85
Steam heat exchanger final rinsing	Article no. 11.10.00.82
DLWA-BS-1 blow-off unit, + 5 kW output, Total length +2,300 mm	Article no. 11.10.00.89
DLWA-BS-2 blow-off unit, + 10 kW output, Total length +3,200 mm	Article no. 11.10.00.88
Box turner, one-man operation DLWA-250 + blow-off	Article no. 11.10.00.78
Box turner, one-man operation DLWA-400 + blow-off	Article no. 11.10.00.77
Gravity roller conveyor, straight or as a curve	on request

### TECHNICAL DATA

Mains supply	3x 400 V; N/PE; 50 Hz
Connected load	26 kW [DLWA 250-BACK] 39 kW [DLWA 400-BACK]
Water connection	3/4"; 15 - 85 °C; 2 - 6 bar; 2 - 8 °dH
Water drain	DN 50
Exhaust air socket	DN 250
Water consumption	approx. 300 - 400 l/h
Tank volume	approx. 400 l [DLWA 250-BACK] approx. 500 l [DLWA 400-BACK]
Tank heater	2x 10 kW [DLWA 250-BACK] 3x 10 kW [DLWA 400-BACK]
Feeding height	950 mm
Washing tunnel dimensions	W: 610 x H: 410 mm
Washing tunnel length	1,800 mm [DLWA 250-BACK] 2,700 mm [DLWA 400-BACK]

**TYPE DLWA 300/2+PAL - 400/2+PAL HIGHLINE****Single tank pass-through washing system for boxes and pallets**

DLWA 300/2+PAL Highline

Pass-through washing system for cleaning boxes and pallets with a passage height of 310 mm and a maximum passage width of once 820 [1-lane] or twice 410 mm [2-lane].

**SYSTEM LAYOUT**

In 2 lanes, the boxes are conveyed through the machine slightly inclined outward. The pallets are also guided longitudinally, but in 1 lane over a further, centre track belt (Scanbelt 1702, tensile strength 1 t).

Stable as well as insulated machine housing made of one piece - with low energy consumption!

**SYSTEM LAYOUT**

- Stable machine housing, double-walled, insulated, made of one piece and completely welded, low energy consumption
- Nozzle arms with stainless steel nozzles can be removed and cleaned without any tools (Nozzle arms with forced positioning)
- Infeed table: Length 1,500 mm, for easy manual feeding
- Strong stainless steel centrifugal pump with high circulation and strong wash pressure; spread over a total of 11 nozzle arms
- Large and easily cleanable external filter box with funnel overflow
- Electric tank heater: 30 kW; optional with steam direct or via heat exchanger
- Special filament heaters made of heat-resistant stainless steel, easy to clean, secure against burn-through
- Main wash zone: Washing temperature 50 - 55 °C
- Final rinsing zone: Fresh water can be heated to 82° Celsius via electric boiler or steam counterflow heater [depending on the flow temperature]
- Outlet table: Length 1,500 mm with limit switch (Belt + final rinsing stop with full outfeed table)
- Optionally with blow-off tunnel in different performance levels, depending on desired blow-off result



	TYPE DLWA 300/2 + PAL	TYPE DLWA 400/2 + PAL
<b>BOXES/H</b>	200 - 300	400 - 500
<b>H1 PALLETS/H</b>	50 - 70	100 - 120
<b>TANK VOLUME</b> with plate filter	400 l	500 l
<b>TANK VOLUME</b> with outside box filter	600 l	800 l
<b>TANK VOLUME</b> with drum filter	800 l	800 l
<b>MAIN WASH ZONE</b> in mm	L: 1800	L: 2700
<b>PUMP</b> Main wash zone	7.5 kW; 1,000 l/m; 2.5 bar	11 kW; 1,000 l/m; 3 bar
<b>HEATING CAPACITY MAIN WASH TANK</b> in kW	30	30
<b>TOTAL LENGTH</b> in mm	4800	5700
<b>ARTICLE NO.</b>	11.10.00.48	11.10.01.27

#### OPTIONS

Fresh water pre-injection DLWA 300/2 + PAL with water supply temperatures less than 45 °C	Article no. 11.10.00.67
Fresh water pre-injection DLWA 300/2 + PAL with water supply temperatures larger than 50 °C	Article no. 11.10.00.66
Vapour exhaust 2x required	Article no. 11.10.02.74
Tank heater with direct steam	Article no. 11.10.00.84
Tank heater with indirect steam	Article no. 11.10.00.83
Rinsing boiler, output 1x 10 kW	Article no. 11.10.00.86
Rinsing boiler, output 2x 10 kW	Article no. 11.10.00.85
Steam heat exchanger final rinsing	Article no. 11.10.00.82
DLWA-BSP-1 blow-off unit, + 5 kW output, Total length +2,300 mm	Article no. 11.10.00.76
DLWA-BSP-2 blow-off unit, + 10 kW output, Total length +3,200 mm	Article no. 11.10.00.75

#### TECHNICAL DATA

Mains supply	3x 400 V; N/PE; 50 Hz
Water connection	3/4"; 15 - 85 °C; 2 - 6 bar; 2 - 8 °dH
Water drain	DN 50
Exhaust air socket	DN 250
Water consumption	approx. 300 - 400 l/h
Tank heater	3x 10 kW
Feeding height	950 mm
Washing tunnel dimensions	W: 820 x H: 310 mm [1-lane] W: 410 x H: 310 mm [2-lane]

**TYPE DLWA 600-2T/2+PAL, 1000-2T/2+PAL HIGHLINE****Multi tank pass-through washing system for boxes and pallets**

Pass-through washing system for cleaning boxes and pallets with a passage height of 310 mm and a maximum passage width of once 820 [1-lane] or twice 410 mm [2-lane].

**SYSTEM LAYOUT**

In 2 lanes, the boxes are conveyed through the machine slightly inclined outward. The pallets are also guided longitudinally, but in 1 lane over a further, centre track belt (Scanbelt 1702, tensile strength 1 t).

Stable as well as insulated machine housing made of one piece - with low energy consumption!

**SYSTEM LAYOUT**

- Stable machine housing, double-walled, insulated, made of one piece and completely welded, low energy consumption
- Pre-wash zone
- Nozzle arms with stainless steel nozzles can be removed and cleaned without any tools (Nozzle arms with forced positioning)
- Infeed table: Length 1,500 mm, for easy manual feeding
- Strong stainless steel centrifugal pump with high circulation and strong wash pressure
- Large and easily cleanable external filter box with funnel overflow
- Electric tank heater: optional with steam directly or via heat exchanger
- Special filament heaters made of heat-resistant stainless steel, easy to clean, secure against burn-through
- Main wash zone: Washing temperature 50 - 55 °C
- Final rinsing zone: Fresh water heated to 82 °C via electric boiler or steam countercurrent
- Outlet table: Length 1,500 mm with limit switch (Belt + final rinsing stop with full outfeed table)
- Optionally with blow-off tunnel in different performance levels, depending on desired blow-off result

	TYPE DLWA 600-2T/2 + PAL	TYPE DLWA 800-2T/2 + PAL	TYPE DLWA 1000-2T/2 + PAL
<b>BOXES/H</b>	500 - 800	700 - 1000	900 - 1200
<b>H1 PALLETS/H</b>	120	150	150
<b>PREWASH</b> in mm	L: 1800	L: 2700	L: 3600
<b>PUMP</b> Prewash	4 kW; 1,200 l/m; 1.5 bar	5.5 kW; 1,500 l/m; 2 bar	5.5 kW; 1,500 l/m; 2 bar
<b>TANK VOLUME</b> with outside box filter	600 l + 800 l	600 l + 800 l	800 l + 800 l
<b>TANK VOLUME</b> with drum filter	1,000 l + 1,000 l	1,000 l + 1,000 l	1,200 l + 1,000 l
<b>MAIN WASH ZONE</b> in mm	L: 2700	L: 2700	L: 2700
<b>PUMP</b> Main wash zone	11 kW; 1,000 l/m; 3 bar	11 kW; 1,000 l/m; 3 bar	2x 11 kW; 1,000 l/m; 5 bar
<b>HEATING CAPACITY MAIN WASH TANK</b> in kW	30	40	40
<b>TOTAL LENGTH</b> in mm	7500	8400	9300
<b>ARTICLE NO.</b>	11.10.01.28	11.10.01.29	11.10.01.30

#### OPTIONS

Fresh water pre-injection DLWA 300/2 + PAL with water supply temperatures less than 45 °C	Article no. 11.10.00.67
Fresh water pre-injection DLWA 300/2 + PAL with water supply temperatures larger than 50 °C	Article no. 11.10.00.66
Vapour exhaust 2x required	Article no. 11.10.02.74
Tank heater with direct steam	Article no. 11.10.00.84
Tank heater with indirect steam	Article no. 11.10.00.83
Rinsing boiler, output 1x 10 kW	Article no. 11.10.00.86
Rinsing boiler, output 2x 10 kW	Article no. 11.10.00.85
Steam heat exchanger final rinsing	Article no. 11.10.00.82
DLWA-BSP-1 blow-off unit, + 5 kW output, Total length +2,300 mm	Article no. 11.10.00.76
DLWA-BSP-2 blow-off unit, + 10 kW output, Total length +3,200 mm	Article no. 11.10.00.75
DLWA-BSP-3 blow-off unit + 15 kW output Total length +3,700 mm	Article no. 11.10.01.31

#### TECHNICAL DATA

Mains supply	3x 400 V; N/PE; 50 Hz
Water connection	3/4"; 15 - 85 °C; 2 - 6 bar; 2 - 8 °dH
Water drain	DN 50
Exhaust air socket	DN 250
Water consumption	approx. 300 - 400 l/h
Feeding height	950 mm
Washing tunnel dimensions	W: 820 x H: 310 mm [1-lane] W: 410 x H: 310 mm [2-lane]

**TYPE DLWA-PAL**

## Pallet washing system

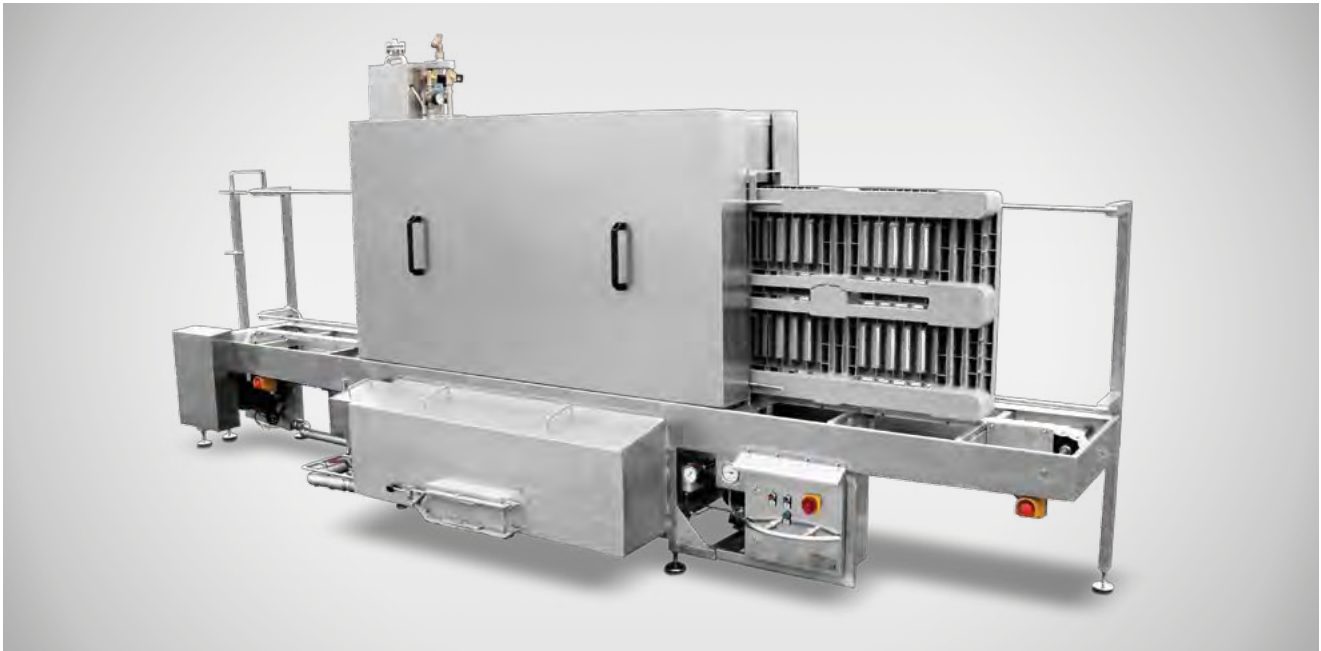

### SYSTEM LAYOUT

- Very stable machine housing, made of one piece and completely welded, support material is mainly made of 3 mm stainless steel sheet, low energy consumption
- Washing frames can be removed and cleaned without any tools, stainless steel nozzles with large passage and optimized drop size
- Very easy cleaning possibilities due to large side flaps, 1 side can be completely opened
- Special filament heaters made of heat-resistant stainless steel, easy to clean, secure against burn-through
- Infeed conveyor 1,400 mm with drive for pallet infeed, control via LENZE frequency inverter
- Main washing zone with 4 kW EDUR stainless steel centrifugal pump, 1,000 l/min. circulation at 2 bar wash pressure, distributed to 60 stainless steel nozzles with large passage for excellent washing results
- Required electrical heating power 20 kW, optionally via steam or hot water heat exchanger; DLWA-PAL 2+3: 30 kW Heating power
- Recommended washing temperature 45 - 50°C
- Thorough final rinsing with fresh water from all sides and outfeed conveyor with limit switch

### MACHINE TYPES

**Type DLWA-PAL-1**, standard type with one washing, Total length: 4,600 mm, output: 30 - 60 pallets/h

**Type DLWA-PAL-2**, as Type 1, but with extended washing zone and 2 pumps with 4 kW each, output: 40 - 80 pallets/h, depending on the degree of soiling, total length: 6,600 mm

**Type DLWA-PAL-3**, as Type 1, but with extended washing zone and 2 pumps of 4 kW each, capacity 50 - 100 pallets/h, depending on the degree of soiling, Total length 6600mm, with brush device [MINK brush approx. 850 mm long] for cleaning the top of the pallet, the brush device is located between the two washing zones

TYPE	DIMENSIONS W x D x H in mm	ARTICLE NO.
DLWA-PAL I	4600 x 1000 x 1900	11.10.00.35
DLWA-PAL II	6600 x 1000 x 1900	11.10.00.36
DLWA-PAL III	6000 x 1000 x 1900	11.10.00.37

## Machine with vertical transport

Standard type for pallets 1,200 x 800 mm  
or optionally 1,200 x 1,000 mm

### OPTIONS

Tank heater per steam direct	Article no. 11.10.00.84
Tank heating indirectly via steam or hot water heat exchanger	Article no. 11.10.00.83
Elevation of the washing tunnel for 1,200 x 1,000 mm Pallets for DLWA-PAL-1	Article no. 11.10.02.50
Elevation of the washing tunnel for 1,200 x 1,000 mm Pallets for DLWA-PAL-2	Article no. 11.10.02.51
Elevation of the washing tunnel for 1,200 x 1,000 mm Pallets for DLWA-PAL-3	Article no. 11.10.02.52
BS1 blow-off, 5 kW high-pressure fan, blow-off only from the working side, machine extension 3,000 mm	Article no. 11.10.02.55
BS2 blow-off, 2x 5 kW high-pressure fan, Blow-off from both sides, machine extension by 3,000 mm	Article no. 11.10.02.56

### TECHNICAL DATA

Mains supply	3x 400 V; N/PE (depending on equipment)
Pump performance	4.0 kW each; 1,000 l/min at 2 bar EDUR
Water connection	3/4"; min. 45 °C; min. 2 - 6 bar
Water drain	DN 50 (drainage into floor drain)
Water consumption	300 - 400 l/h
Tank volume	400 l (DLWA-PAL 1), 800 l (DLWA-PAL 2 + 3)
Heating power	20/30 kW <sup>1</sup> (electric or steam)
Rated power	30 - 100 pallets <sup>1</sup> /h
Washing tunnel dimensions	W: 180 x H: 820 mm
Dimensions	L: 4,600/6,600 <sup>2</sup> mm, W: 1,000 mm, H: 1,900 mm

<sup>1</sup> Depending on the type and pollution degree

<sup>2</sup> Including feed and withdrawal belt

**TYPE KWA-HBW-200/ 300**

# Cabin washing system







Hedgehog nozzle

For lift trucks and feed trolleys 200/300 litres according to DIN 9797

**SYSTEM LAYOUT**

- Cleaning of 15 - 25 trolleys hourly (200 or 300 l) with normal to strong soiling
- Due to 180° position of the trolley, the cleaning of all sides is possible (also in the area of the wheels and the bottom)
- Hedgehog nozzle enables thorough cleaning of the container interior, nozzle head can be screwed off and is thus easy to clean
- Interior floor with sloped plates above washing tank, washing water is guided from the machine outside into the filter area and from there into the tank. Advantage: No direct soiling in the machine interior, no coarse dirt in the tank
- SIEMENS-S7-1200-Steuerung with SIEMENS touch screen monitor and display of all parameters
- Wash programs with selectable treatment durations (e.g. short, medium, long)
- Large wash tank for taking up large amounts of dirt (e.g. protein soiling)
- Low energy consumption, tank double-wall isolated
- Stable, completely welded machine with massive frame and high material thicknesses
- Strong 15 kW EDUR stainless steel centrifugal pump 1,500 l/min at 4 bar wash pressure
- All gear motors can be easily dismantled via shrink disc connections

**OPTIONS**

Drum filter for automatic dirt discharge	Article no. 11.10.02.73
Vapour exhaust 1,500 m3/h at 800 Pa	Article no. 11.10.02.74
Direct tank heater via steam	Article no. 11.10.02.75
Indirect tank heater via steam	Article no. 11.10.02.76
Tank heating via hot water or thermal oil heat exchanger	Article no. 11.10.02.81
10 kW electric boiler for heating the rinse water	Article no. 11.10.02.77
20 kW electric boiler for heating the rinse water	Article no. 11.10.02.79
Steam counterflow for heating the rinse water	Article no. 11.10.02.78
Special support for similar container sizes	on request

**TECHNICAL DATA**

Mains supply	3x 400 V; N/PE (depending on equipment)
Connected load	
Steam heating	16 kW
Connected load	
Electric heating (10 kW)	approx. 40 - 50 kW (incl. 10 kW rinse boiler)
Connected load	
Electric heating (20 kW)	approx. 40 - 50 kW (incl. 20 kW rinse boiler)
Connected load	
Hot water heating	27 kW
Water connection	3/4"; Temp. 10 - 85 °C; min. 3 - 6 bar
Water drain	DN 50 (drainage into floor drain)
Tank content	1000 l
Air connection	1/2"
Exhaust air	DN 250
With hot-water connection	1 1/4" (for supply and return)
With steam connection	1 - 6 bar (direct or indirect)

TYPE	CAPACITY HBW	ARTICLE NO.
KWA-200	1x 200 ltr.	11.10.02.70
KWA-300	1x 200 or 300 ltr.	11.10.02.71

**DIMENSIONS KWA-200**

Tank on the left or right side:  
 W: 2,800 x 2,730 x 2,500 mm (KWA-300: H: 2,800 mm)  
 Tank behind the system:  
 W: 1,665 x 3,870 x 2,500 mm (KWA-300: H: 2,800 mm)

**TO THE PRODUCT FILM**

**TYPE KWA-DUO, -STB, -RPB**  
**Cabin washing system**



Cabin washing system KWA-RPB



For 2 lift and feed trolleys [200/300 litres] according to DIN 9797, stacking container and pallet boxes.

**SYSTEM LAYOUT**

- Version as described on page 142 but:
- **KWA-DUO:** simultaneous cleaning of 2 pieces of standard trolleys [200 l or 300 l], capacity 30 - 50 trolleys/h with normal to heavy soiling
- **KWA-STB:** for cleaning of one stacking or brine container, Capacity 15 - 25 containers/h with normal to heavy soiling
- **KWA-RPB:** for cleaning plastic paloxes, capacity 8 - 15 paloxes/h with normal to heavy soiling
- **Special feature KWA-RPB:** During the washing and rinsing process, the paloxe continuously rotates around its own axis; only lowest amounts of water remain in the bottom ribbing of the boxes. This significantly reduces water discharge and consumption.
- 2 powerful EDUR stainless steel centrifugal pumps for optimum cleaning
- External cleaning: 1x 15 kW, circulation 1,500 l/min at 4 bar washing pressure
- Internal cleaning: 1x 15 kW, circulation 1,000 l/min at 6 bar washing pressure

**OPTIONS**

Drum filter for automatic dirt discharge	Article no. 11.10.02.73
Vapour exhaust 1,500 m3/h at 800 Pa	Article no. 11.10.02.74
Direct tank heater via steam	Article no. 11.10.02.75
Indirect tank heater via steam	Article no. 11.10.02.76
Tank heating via hot water or thermal oil heat exchanger	Article no. 11.10.02.81
10 kW electric boiler for heating the rinse water	Article no. 11.10.02.77
20 kW electric boiler for heating the rinse water	Article no. 11.10.02.79
Steam counterflow for heating the rinse water	Article no. 11.10.02.78
Special support for similar container sizes	on request

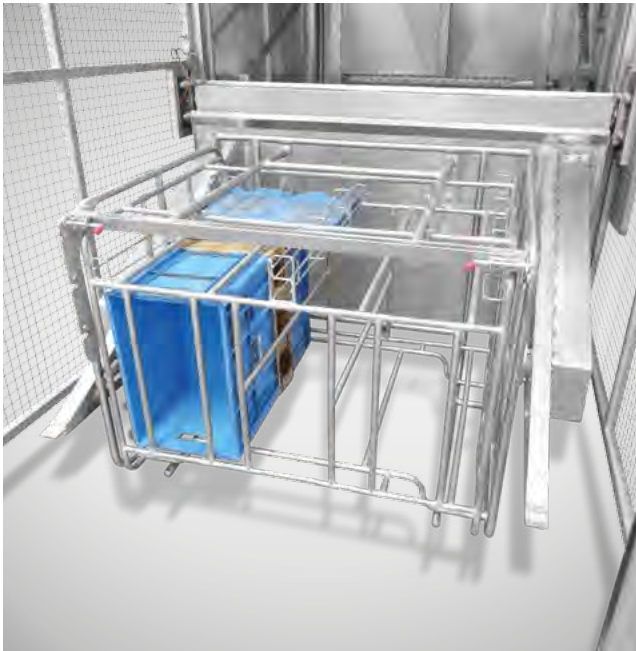

02

**TECHNICAL DATA**

Mains supply	3x 400 V; N/PE (depending on equipment)
Connected load	
Steam heating	32 kW
Connected load	
Electric heating [10 kW]	approx. 50 - 60 kW (incl. 10 kW rinse boiler)
Connected load	
Electric heating [20 kW]	approx. 50 - 60 kW (incl. 20 kW rinse boiler)
Connected load	
Hot water heating	43 kW
Water connection	3/4", temp. 10 - 85 °C; min. 3 - 6 bar
Water drain	DN 50 (drainage into floor drain)
Water consumption	approx. 10 - 30 litres per flushing process
	[adjustable]
Tank content	2,000 l
Air connection	1/2"
Exhaust air	DN 250
With hot-water connection	1 1/4" (for supply and return)
With steam connection	1 - 6 bar (direct or indirect)

TYPE	CAPACITY	ARTICLE NO.
KWA-DUO	2x HBW (200/300)	11.10.02.72
KWA-STB	1x stacking container	11.10.02.89
KWA-RPB	1x pallet box	11.10.02.90

**DIMENSIONS WITH LATERAL TANK**  
 W: 3,530 x D: 5,025 x H: 3,000 mm

 [TO THE PRODUCT FILM](#)

**TYPE DLWA-HBW****Feed trolleys - pass-through washing system**

**For cleaning typical soiled lift and feed trolleys Type 200 ltr.; output 30 to 60 pieces/h depending on the relevant model.**

The feed and removal of the 200 litres feed trolleys takes place by automatic infeed and outfeed stations.

- Automatic swivel device in the inlet and outlet (see options) for one trolley each (hourly output approx. 30 trolleys) or two trolleys (hourly performance approx. 60 trolleys)
- For thorough inside and outside cleaning, the trucks are lifted to conveyor track level and simultaneously tilted to more than 180°.

**SYSTEM LAYOUT**

- Self-supporting, completely double-walled, soundproof and heat insulated machine housing, made of one piece and completely welded, low energy consumption
- Tank 3 mm thick, tank interior rounded with R: 30 mm, can be cleaned from the rear side, with an additional opening
- Washing tunnel on both sides with maintenance doors
- Washing frames can be removed and cleaned without any tools, nozzles with large passage (washing frames with forced positioning)
- Control via SIEMENS S7 with Pro Face Touch Screen, monitoring of all parameters
- 2,000 mm infeed table, cleaned parts transport via 2 Scanbelt chains
- Washing tunnel 3.000 mm long with 2 large external box filters
- EDUR stainless steel centrifugal pump 22 kW, circulation 1,800 l/min at 4 bar washing pressure for interior and exterior cleaning
- Electrical heating approx. 50 kW, optional with direct or indirect steam
- Active wash zone passage width approx. 750 mm, with stable end guides
- Passage height approx. 1,300 mm (other dimensions are possible)
- Final rinsing with 1,000 mm zone length; Fresh water rinsing opens only with trolleys passing by
- Outfeed length: 1,500 mm
- Cleaning of 300-litre standard trolleys on request





**OPTIONS**

Direct tank heater via steam	Article no. 11.10.00.84
Indirect tank heater via steam	Article no. 11.10.00.83
10 kW electric boiler for heating the rinse water	Article no. 11.10.00.86
20 kW electric boiler for heating the rinse water	Article no. 11.10.00.85
Steam counterflow for heating the rinse water	Article no. 11.10.00.82
Drum filter for automatic dirt discharge	Article no. 11.10.02.73
Infeed station 1 for one trolley	Article no. 11.10.00.74
Infeed station 2 for two trolleys	Article no. 11.10.00.72
Vapour exhaust 1,500 m <sup>3</sup> /h 2x required	Article no. 11.10.02.74

TYPE	CAPACITY	ARTICLE NO.
DLWA-HBW	30 - 60 HBW per h	11.10.00.49

**DIMENSIONS DLWA-HBW**

Total length without infeed and outfeed station: 7,500 mm  
 Total length including infeed and outfeed station: 10,500 mm

**TECHNICAL DATA**

Mains supply	3x 400 V; N/PE; 50 Hz (with electr. heating plus 50 kW heating power!)
Connected load	25 kW
Water connection	3/4"; min. 40 °C; 2 - 6 bar; 2 - 8 °dH
Water drain	DN 70
Exhaust air socket	DN 250 (at 2 points)
Water consumption	approx. 800 - 1000 l/h (adjustable)
Tank volume	1,500 l
Steam connection	3/4"; 1 - 6 bar; operating requirement 100 kg/h Washing temperature approx. 48°C
Steam demand final rinsing	approx. 50 - 60 kg/h, heat output 50 kW
Compressed air	1/4" [100 l/h; 6 bar] (for the control of the steam control valve)
Washing tunnel dimensions	W: 750 x H: 1,300 mm
Active wash zone	3,000 mm

**TYPE DLWA-GB**

## Large container - pass-through washing system



**SYSTEM LAYOUT**

- Completely double-walled, soundproof and heat insulated machine housing made of one piece and completely welded, low energy consumption
- Infeed lane with 3,000 mm long drive
- Infeed table 1,500 mm long
- The infeed area is followed by a 1,000 mm long neutral zone and the inlet into the wash area
- EDUR stainless steel centrifugal pump 22 kW, circulation 2,000 l/min at 5 bar washing pressure
- Tank 2,000 l with extra large external box filter, electric heating, optional with direct or indirect steam
- Washing tunnel passage width approx. 850 mm
- Internal tunnel height up to 1,050 mm
- Drip-off line: 1,000 mm long
- Final rinsing with directly inflowing fresh water, valve opens only with the palox passing by, flush zone length 1,000 mm, optionally with fresh water heating to > 82 °C, electric or with steam (depending on the flow temperature)
- Outfeed table 1,500 mm long
- Outlet without drive via gravity roller conveyor with limit stop approx. 4,000 mm long
- Extraction via KARL KLEIN stainless steel radial fan 1,500 m3/ h at 500 Pa

For cleaning plastic paloxes 1,200 x 800 x 800 mm; output 45 pieces/h with fresh, slight to medium soiling.

The infeed or outfeed of cleaning parts takes place lying on the side in the 1,200 mm long inlet and outlet area.

**OPTIONS**

Direct tank heater via steam	Article no. 11.10.00.84
Indirect tank heater via steam	Article no. 11.10.00.83
10 kW electric boiler for heating the rinse water	Article no. 11.10.00.86
20 kW electric boiler for heating the rinse water	Article no. 11.10.00.85
Steam counterflow for heating the rinse water	Article no. 11.10.00.82
Drum filter for automatic dirt discharge	Article no. 11.10.02.73
Vapour exhaust 1,500 m3/h at 800 Pa 2x required	Article no. 11.10.02.74





**TECHNICAL DATA**

Mains supply	3x 400 V; N/PE; 50 Hz
Connected load	25 kW (with electr. heating plus 50 kW heating power!)
Water connection	3/4"; min. 45 °C; 2 - 6 bar; 2 - 8 °dH
Water drain	DN 70
Exhaust air socket	DN 250 (on 3 points)
Water consumption	approx. 800 - 1,200 l/h [adjustable]
Tank volume	2,000 l
Steam connection	3/4"; 1 - 6 bar; operating requirement 100 kg/h Washing temperature approx. 48°C
Steam demand final rinsing	approx. 50 - 60 kg/h; heat output 50 kW
Compressed air	1/4" [100 l/h; 6 bar] [for the control of the steam control valve]
Washing tunnel dimensions	W: 850 x H: 1,050 mm
Active wash zone	3,000 mm
Washing tunnel	5,000 mm consisting of: 1,000 mm neutral zone, 2,000 mm washing zone, 1,000 mm drip-off zone, 1,000 mm clear rinsing

TYPE	CAPACITY	ARTICLE NO.
DLWA-GB	45 paloxes per h	11.10.01.16

**DIMENSIONS DLWA-GB**

Total length: 15,000 mm

Other hourly rates  
on request!

**TYPE KWA-UDT**

# Cabin washing system



Detail: Rotary plate

**Universal washing system for industrial use**

**SYSTEM LAYOUT**

- Double-walled, soundproof and heat insulated Machine housing made of one piece and completely welded = low energy consumption
- Stable, stainless steel door, double-walled with 3 tumblers and safety switch monitoring
- Intensive washing and low consumption of chemicals due to self-cleaning "Crossflow" round hole nozzle pipes with drive
- Large-volume wash tank made from 4 - 6 mm stainless steel sheet [Content approx. 1,000 litres] with large filter surface to take up high dirt freights
- Tank heating via 20 kW electrical heating or direct / indirect steam heating
- 2 strong washing pumps with 7.5 kW output each, high circulation, high pressure
- Large washroom, platform diameter 1600 mm to accommodate different wash items, platform rotates 2.5 - 3 times per minute
- Rotary plate with stronger drive on request for centrifugal drying of the cleaning goods [Type KWA-UDT-Dry]
- Maintenance-prone hose connections as well as vulnerable up and down movements are dropped, and the washing system is 100 % self-cleaning

- Integrated vapour exhaust on the machine roof 1,500m<sup>3</sup> at 500 Pa
- Depending on the installation situation, mounting of the machine takes place in the floor by means of a pit. Alternatively, on the floor with an infeed slope, or on floor level with stand-alone tank. [Pump sump in the floor is required!]
- Optional with individual take-up trolley for customer-specific items to be washed

TYPE	CENTRIFUGAL FUNCTION	ARTICLE NO.
KWA-UDT	No	11.10.02.91
KWA-UDT-Dry	Yes	11.10.02.92

For cleaning smoke trolleys, oven racks and other cleaning parts.  
Hourly output approx. 8-12 batches, depending on the degree of soiling [up to 24 H- or Z-shape smoke trolleys]

**OPTIONS**

Direct tank heater via steam	Article no. 11.10.02.75
Indirect tank heater via steam	Article no. 11.10.02.76
Hot water or thermal oil heat exchanger for wash tank	Article no. 11.10.02.81
10 kW electric boiler for heating the rinse water	Article no. 11.10.02.77
20 kW electric boiler for heating the rinse water	Article no. 11.10.02.79
Steam counterflow for heating the rinse water	Article no. 11.10.02.78
Waste water heat exchanger for fresh water heating	Article no. 11.10.02.80
Two-door machine for zone separation, clean/unclean	Article no. 11.10.02.82

**TECHNICAL DATA**

Mains supply	3x 400 V; N/PE
Connected load	16 kW [plus 20 kW with electrical heating in the tank]
Water connection	3/4", temp. 12 °C; 1 - 6 bar
Water drain	DN 50 [drainage into floor drain]
Tank content	approx. 1,000 ltr.
Heating power	20 kW [required]
Exhaust air point	DN 250
Compressed-air connection	1/4" < 100 l/h [only with steam or hot water heating for control valve]
With hot-water connection	1 1/4" [for supply and return]
With steam connection	3/4"; 1 - 6 bar [direct or indirect]

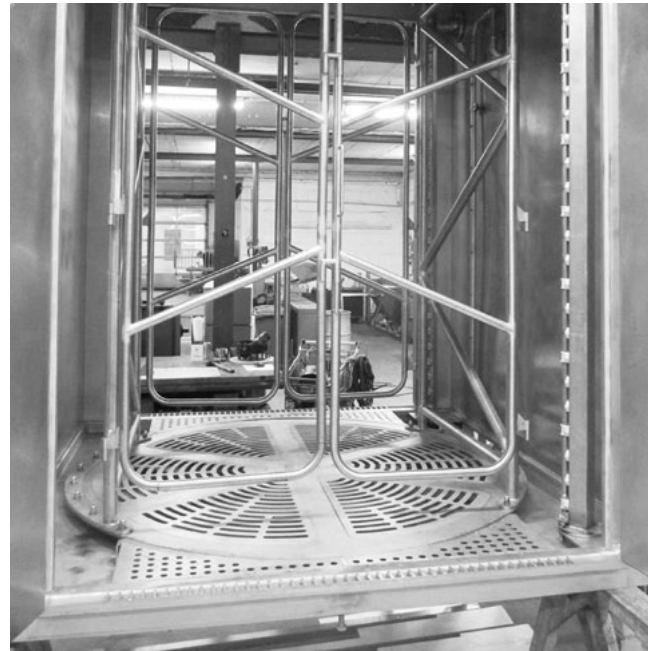

Detail: Transit version with additional rear door

**DIMENSIONS WITH LATERAL TANK**

W: 2,530 x D: 1,858/3,075 x H: 2,475/3,000 mm

**POSSIBLE ITEMS TO BE WASHED**

- Smoke trolleys
- Lift and feed trolleys
- Oven rack
- Pallet stacks
- Waste bin 120 litres or 240 litres
- Pallet boxes
- Knife basket trolley
- and much more

**TO THE PRODUCT FILM**

**TYPE KWA-UGR**

## Cabin washing system



KWA-UGR with 6 trolleys

Hourly output approx. 6 - 10 batches depending on the degree of soiling and items to be washed.

### SYSTEM LAYOUT

- Double-walled, soundproof and heat insulated Machine housing made of one piece and completely welded = low energy consumption
- Large washing chamber: total washing area e.g. 5.0 m<sup>2</sup> or individually designed to your needs depending on the item to be washed
- Stable, double-walled and double door stainless steel door, Drive-in width: 1,650 mm
- The whole support is manufactured from very stable 6 mm stainless steel sheet and easy to clean to easily removable tread plates with break-throughs
- The roof is designed in two-side slopes, thus it is avoided that suds remnants can drip onto the machine interior roof onto the trolley after fresh water rinsing
- Multifunctional use: simultaneous cleaning of most different items to be washed possible, e.g. smoke trolleys, cutter trolleys, pallets, pallets and much more Racks to clean cutter trolleys, pallets et cetera on request
- Self-cleaning "crossflow spraying" (in total 12 driven nozzle pipes), the spray pipes rotate with changing spray angles for secure covering of the surfaces

- Due to the nozzle drive via a gear motor, there occurs no loss of efficacy as with water-driven nozzle pipes or nozzles
- Large-volume wash tank made of 6 mm stainless steel sheet [Content approx. 2,800 litres] with large filter surface to take up high dirt freights
- Tank heating via 40 kW electrical heating or direct / indirect steam heating
- 2 powerful wash pumps, each with 15 kW output, at the side of the system in large maintenance compartment can be opened via 2 doors, circulation 3,500 litres/min. at a washing pressure of 3.5 - 4.5 bar
- Maintenance-prone hose connections as well as vulnerable up and movements are dropped, and the washing system is 100 % self-cleaning
- Integrated vapour exhaust on the machine roof 1,500m<sup>3</sup> at 500 Pa
- SIEMENS S7-1200 controller with Pro-Face touchscreen

For simultaneous cleaning of 6 pieces of Z-shape smoke trolleys or other items to be washed, for example, such as feed trolleys, paloxes or similar, depending on the model and size.

**OPTIONS**

Direct tank heater via steam	Article no. 11.10.02.75
Indirect tank heater via steam	Article no. 11.10.02.76
Hot water or thermal oil heat exchanger for wash tank	Article no. 11.10.02.81
10 kW electric boiler for heating the rinse water	Article no. 11.10.02.77
20 kW electric boiler for heating the rinse water	Article no. 11.10.02.79
Steam counterflow for heating the rinse water	Article no. 11.10.02.78
Waste water heat exchanger for fresh water heating	Article no. 11.10.02.80
Two-door machine for zone separation, clean/unclean	Article no. 11.10.02.82
Racks for various wash items [e.g. for feed trolleys]	on request

**TECHNICAL DATA**

Mains supply	3x 400 V; N/PE
Connected load	32 kW [plus 40 kW with electrical heating in the tank]
Water connection	2x 1"; 3 - 6 bar
Water drain	DN 70 [drainage into DN 100 floor drain]
Tank content	approx. 2,800 litres
Heating power	40 kW [required]
Exhaust air point	DN 250
Compressed-air connection	1/4" < 100 l/h [only with steam or hot water heating for control valve]
With hot-water connection	1 1/4" [for supply and return]
With steam connection	1"; 2 - 6 bar [direct or indirect]



TYPE	VERSIONS	ARTICLE NO.
KWA-UGR	Large room	11.10.02.93

**DIMENSIONS**

Dimensions individually matched to your requirements!

 [TO THE PRODUCT FILM](#)



## Low-pressure foam technology

---



Mohn provides a dynamic, purpose-driven technology portfolio with Ecolab-systems for flexible and cost-effective hygiene solutions suitable for all application areas and system sizes.

We offer both mobile and stationary systems and systems to cater to the full spectrum of applications. All of these systems stand for excellent functionality, superior safety and control, as well as simple and effective handling.

When planning a foam cleaning system for surface hygiene in the food and beverage industry, a variety of technical requirements must be taken into account. Mohn provides on-site support to ensure a smooth commissioning and use of the facilities.





02

**HANDLE GRIFF, TYPHOON**

**Foam technology packages mobile**



Foam technology package 1, Griff



Foam technology package 2, Typhoon

**FOAM TECHNOLOGY PACKAGE 1**

**GRIFF MOBIL**

Article no. 10.10.10.33

- 1 User
- No continuous use, foam time of 1 - 2 hours daily is however feasible without any issues
- mobile device with water connection [house connection 3 - 8 bar] no storage container
- For 2 chemicals [1x foaming, 1x spray disinfection] and rinse
- Device with water pressure booster: Inlet pressure 3 - 8 bar plus Pressure boosting by means of pump 0.9 kW, 8 bar = total outlet pressure 12- 15 bar
- Incl. compressor for air supply for foaming

**COMPLETE PACKAGE CONSISTING OF:**

- Griff foaming system
- Stainless steel trolley 1.4301 for Griff system
- Trolley with holder for hose, canister holder and nozzle holder
- Supply hose 2.5 m, steel flex
- Working hose 15 m, food-safe
- Gun
- Nozzle set [rinsing nozzle, foam nozzle]

**FOAM TECHNOLOGY PACKAGE 2**

**TYPHOON MOBILE**

Article no. 10.10.10.34

- 1 User
- Incl. compressor for air supply for foaming
- Designed for continuous use, the device allows for persistent foam due to the compressor for up to 4 hours, after which a short rest period [5 - 10 min.] is required before a new foam cycle can commence
- Mobile device with water connection [house connection 3 - 8 bar] no storage container
- Ideally ¾" supply line, alternatively ½", as well as permanent operating pressure of at least 2 bar [not less than ½" as water volume is not sufficient for pressure boosting pump]
- Device with water pressure booster, inlet pressure 3 - 8 bar plus Pressure booster by means of pump 2.2 kW, 20 bar = total outlet pressure 22 - 25 bar
- For 2 chemicals [1x foaming, 1x spray disinfection] and rinsing

**COMPLETE PACKAGE CONSISTING OF:**

- Typhoon foaming device
- Feed hose 5 m with GEKA coupling
- Working hose 25 m
- Foam gun ST2720 V2A
- Nozzle set [rinsing nozzle, foam nozzle, rinsing lance]

**TYPE NAGA, YETI, GRIFF**

## Foam technology packages stationary

**ECOLAB®**



Foam technology package 3, Naga



Foam technology package 4, Yeti



Foam technology package 5, Griff

### FOAM TECHNOLOGY PACKAGE 3 NAGA STATIONARY

Article No.: 10.10.10.30

For small application areas

- 1 User
- Functions: Foaming, spraying, rinsing
- Stationary appliance with water connection [house connection 3 - 8 bar] without storage tank - For 2 chemicals [1x foaming, 1x spray disinfection]
- With selector lever for selection: Chemistry 1, Chemistry 2, Rinsing
- Foam generation using the injector principle [air+water]

#### COMPLETE PACKAGE CONSISTING OF:

- Naga foam cleaning device
- Working hose 10 m
- Foam lance with ball valve
- Foam nozzle and rinsing nozzle
- Hose holder - steel flex hose for water supply line
- 2x suction hose for cleaner incl. set Maximum nozzles for dosing
- 2x wall-mounted canister holder for 1x 24 kg canister each

### FOAM TECHNOLOGY PACKAGE 4 YETI STATIONARY

Article No.: 10.10.10.31

For small application areas

- 1 User
- Function: Foam generation
- Stationary appliance with water connection [house connection 3 - 8 bar] without storage tank
- For 1 chemical [foaming only, no rinse]
- Foam generation using the injector principle [Air + Water]
- For flushing function: a bypass in the water supply for a second tap is recommended above the appliance.
- A suitable quick-release coupling for quickly connecting the hose to the water pipe is included.

#### COMPLETE PACKAGE CONSISTING OF:

- Foam generator Yeti
- Hose 15 m, food-safe
- Hose bracket
- Quick coupling 2x for hose connection to appliance and on-site water connection
- ST 2720 foam gun incl. quick-coupling for hose connection
- Stainless steel nozzle holder with 4 positions
- Foam nozzle + rinsing nozzle
- 1x can holder KH-III for 24 kg

### FOAM TECHNOLOGY PACKAGE 5 GRIFF STATIONARY

Article No.: 10.10.10.32

For medium application areas

- 1 User
- No continuous use, foam time of 1 - 2 hours daily is however feasible without any issues
- Stationary appliance with water connection [house connection 3 - 8 bar] no storage tank
- For 2 chemicals [1x foaming, 1x spray disinfection] and rinsing
- Device with water pressure booster: Inlet pressure 3 - 8 bar plus pressure increase using pump 0.9 kW, 8 bar = total outlet pressure 12 - 15 bar
- Incl. compressor for air supply for foam formation

#### COMPLETE PACKAGE CONSISTING OF:

- Griff foaming system
- Wall bracket for Griff system
- Supply hose 2.5 m, steel flex
- Working hose 15 m, food-safe
- Hose holder, stainless steel
- Gun
- Nozzle set [rinsing nozzle, foam nozzle]
- Wall bracket for nozzle set
- 2x wall-mounted canister holder for 1x 24 kg canister each

**TYPE MD421, 422**

**Foam technology packages with main station**



Foam technology package 6, main station MD 421



Foam technology package 7, main station MD 422

**FOAM TECHNOLOGY PACKAGE 6**

**MAIN STATION MD 421**

Article No.: 10101035

**For larger application areas**

- Up to 4 users simultaneously
- MD 421 main station with plastic housing
- Device designed for continuous use
- Stationary appliance with water connection (house connection 3 - 8 bar) no storage container
- 1 ¼" supply line with a permanent operating pressure of at least 2 bar (otherwise the water volume is not sufficient for the pressure booster pump)
- Integrated booster pump with 5.5 kW output, increase by 20 bar, outlet pressure 22 - 25 bar
- For 2 chemicals (1x foaming, 1x spray disinfection) and rinsing
- Compressed air connection required on the appliance, connection min. 6 bar, max. 10 bar; 200 NI/min (nominal litres/minute)

**COMPLETE PACKAGE CONSISTING OF:**

- Main station MD 421
- Hose reel 20 m and swivelling wall bracket
- Supply hose
- Working hose 20 m
- Gun ST 2700 incl. swivel joint
- 2 can holders each 24 kg open KH-III
- 2 swivel joints
- Quick coupling nipple
- Nozzle kit (incl. rinsing lance)
- Stainless steel nozzle holder
- For details see page 159 (Set complete)

**FOAM TECHNOLOGY PACKAGE 7**

**MAIN STATION MD 422**

Article No.: 10101036

**For larger application areas**

- Up to 4 users simultaneously
- MD 422 main station with plastic housing
- Device designed for continuous use
- Stationary appliance with water connection (house connection 3 - 8 bar) no storage container
- For 2 chemicals (2x foaming) and rinsing
- 1 ¼" supply line with permanent operating pressure of at least 2 bar (otherwise water volume not sufficient for booster pump)
- Integrated booster pump with 5.5 kW output, increase by 20 bar, outlet pressure 22 - 25 bar
- Compressed air connection required on the appliance, connection min. 6 bar, max. 10 bar; 200 NI/min (nominal litres/minute)

**COMPLETE PACKAGE CONSISTING OF:**

- Main station MD 422
- Hose reel 20 m and swivelling wall bracket
- Supply hose
- Working hose 20 m
- Gun ST 2700 incl. swivel joint
- 2 can holders each 24 kg open KH-III
- 2 swivel joints
- Quick coupling nipple
- Nozzle kit (incl. rinsing lance)
- Stainless steel nozzle holder
- For details see page 159 (Set complete)

**TYPE ECOLINE SE11**

**Workplace package**

**ECOLAB®**



Workplace package 1, Ecoline SE11

**WORKPLACE PACKAGE 1**

**ECOLINE SE11**

Article No.: 10101037

Can be combined with all main stations and booster stations!

- 1 chemical (foaming)
- Satellite Ecoline SE11 with 3/4" or 1/2" connection of main or booster station
- For 1 chemical (foaming) and rinse
- Compressed air connection required on the appliance, connection min. 6 bar, max. 10 bar; 200 NI/min (nominal litres/minute)

**COMPLETE PACKAGE CONSISTING OF:**

- Hose reel 20 m 1/2" incl. V2A angled swivel joint and wall slewing console
- Supply hose blue 1/2" stainless steel crimping side 1: 1/2" IG side 2: 1/2"AG, length 3 m from satellite to hose reel - working hose blue 20 m 1/2" stainless steel crimping on both sides 1/2" AG, mounted on hose reel
- Gun ST2700 (without damper) incl. quick coupling
- 2 swivel joints [1x gun connection to working hose, 1x working hose to hose reel] incl. accessories for Connection swivel joint to gun: Double nipple 1/2"
- Quick coupling nipple 1/2" female thread for connecting feed hose to main station Hybrid Compact
- 2 can holders each 24 kg open KH-III - Incl. complete nozzle kit V2A with flush pipe and nozzle holder consisting of:
  - Stainless steel flushing lance 500 mm 25/30 [25° spray angle / 30 litres/min]
  - Foam nozzle stainless steel 50/200
  - Disinfection nozzle stainless steel 25/30
  - Water-saving nozzle stainless steel 00/20 [only for rinsing]
  - Stainless steel nozzle holder with 4 positions

02



**TYPE HIGHLINE SD**

**Workplace packages**



Workplace package 2, Highline SD21-ABS



Workplace package 3, Highline SD22-ABS

**WORKPLACE PACKAGE 2**

**HIGHLINE SD21-ABS**

Article No.: 10101038

Can be combined with all main stations and booster stations!

- 2 chemicals [1x foaming and 1x spraying]
- Satellite SD21 ABS [plastic cover] with 3/4" or 1/2" Connection of main or booster station
- For 2 chemicals [1x foam, 1x spray disinfection] and rinsing
- Compressed air connection required on the appliance, connection min. 6 bar, max. 10 bar; 200 NI/min [nominal litres/minute]

**COMPLETE PACKAGE CONSISTING OF:**

- Hose reel 20 m and swivelling wall bracket
- Supply hose
- Working hose 20 m
- Gun ST 2700 incl. swivel joint
- 2 can holders each 24 kg open KH-III
- 2 swivel joints
- Quick coupling nipple
- Nozzle kit [incl. rinsing lance]
- Stainless steel nozzle holder
- For details see page 159 [Set complete]

**WORKPLACE PACKAGE 3**

**HIGHLINE SD22-ABS**

Article No.: 10101039

Can be combined with all main stations and booster stations!

- 2 chemicals [2x foaming]
- Satellite SD22 ABS [plastic cover] with 3/4" or 1/2" Connection of main or booster station
- For 2 chemicals [2x foaming] and rinsing
- Compressed air connection required on the appliance, connection min. 6 bar, max. 10 bar; 200 NI/min [nominal litres/minute]

**COMPLETE PACKAGE CONSISTING OF:**

- Hose reel 20 m and swivelling wall bracket
- Supply hose
- Working hose 20 m
- Gun ST 2700 incl. swivel joint
- 2 can holders each 24 kg open KH-III
- 2 swivel joints
- Quick coupling nipple
- Nozzle kit [incl. rinsing lance]
- Stainless steel nozzle holder
- For details see page 159 [Set complete]





Workplace package 4, Highline SD21-V2A



Workplace package 5, Highline SD22-V2A

#### WORKPLACE PACKAGE 4

##### HIGHLINE SD21-V2A

Article No.: 10101040

Can be combined with all main stations and booster stations!

- 2 chemicals [1x foaming and 1x spraying]
- Satellite SD21 V2A [stainless steel cover] with  $\frac{3}{4}$ " or  $\frac{1}{2}$ " Connection of main or booster station [see flow chart]
- For 2 chemicals [1x foaming, 1 spray disinfection] and rinse
- Compressed air connection required on the appliance, connection min. 6 bar max. 10 bar; 200 NI/min [nominal litres/minute]

#### COMPLETE PACKAGE CONSISTING OF:

- Hose reel 20 m and swivelling wall bracket
- Supply hose
- Working hose 20 m
- Gun ST 2700 incl. swivel joint
- 2 can holders each 24 kg open KH-III
- 2 swivel joints
- Quick coupling nipple
- Nozzle kit [incl. rinsing lance]
- Stainless steel nozzle holder
- For details see page 159 [Set complete]

#### WORKPLACE PACKAGE 5

##### HIGHLINE SD22-V2A

Article No.: 10101041

Can be combined with all main stations and booster stations!

- 2 chemicals [2x foaming]
- Satellite SD22 V2A [stainless steel cover] with  $\frac{3}{4}$ " or  $\frac{1}{2}$ " connection from main or booster station
- For 2 chemicals [2x foaming] and rinsing
- Compressed air connection required on the appliance, connection min. 6 bar, max. 10 bar; 200 NI/min [nominal litres/minute]

#### COMPLETE PACKAGE CONSISTING OF:

- Hose reel 20 m and swivelling wall bracket
- Supply hose
- Working hose 20 m
- Gun ST 2700 incl. swivel joint
- 2 can holders each 24 kg open KH-III
- 2 swivel joints
- Quick coupling nipple
- Nozzle kit [incl. rinsing lance]
- Stainless steel nozzle holder
- For details see page 159 [Set complete]

## Stationary systems

---

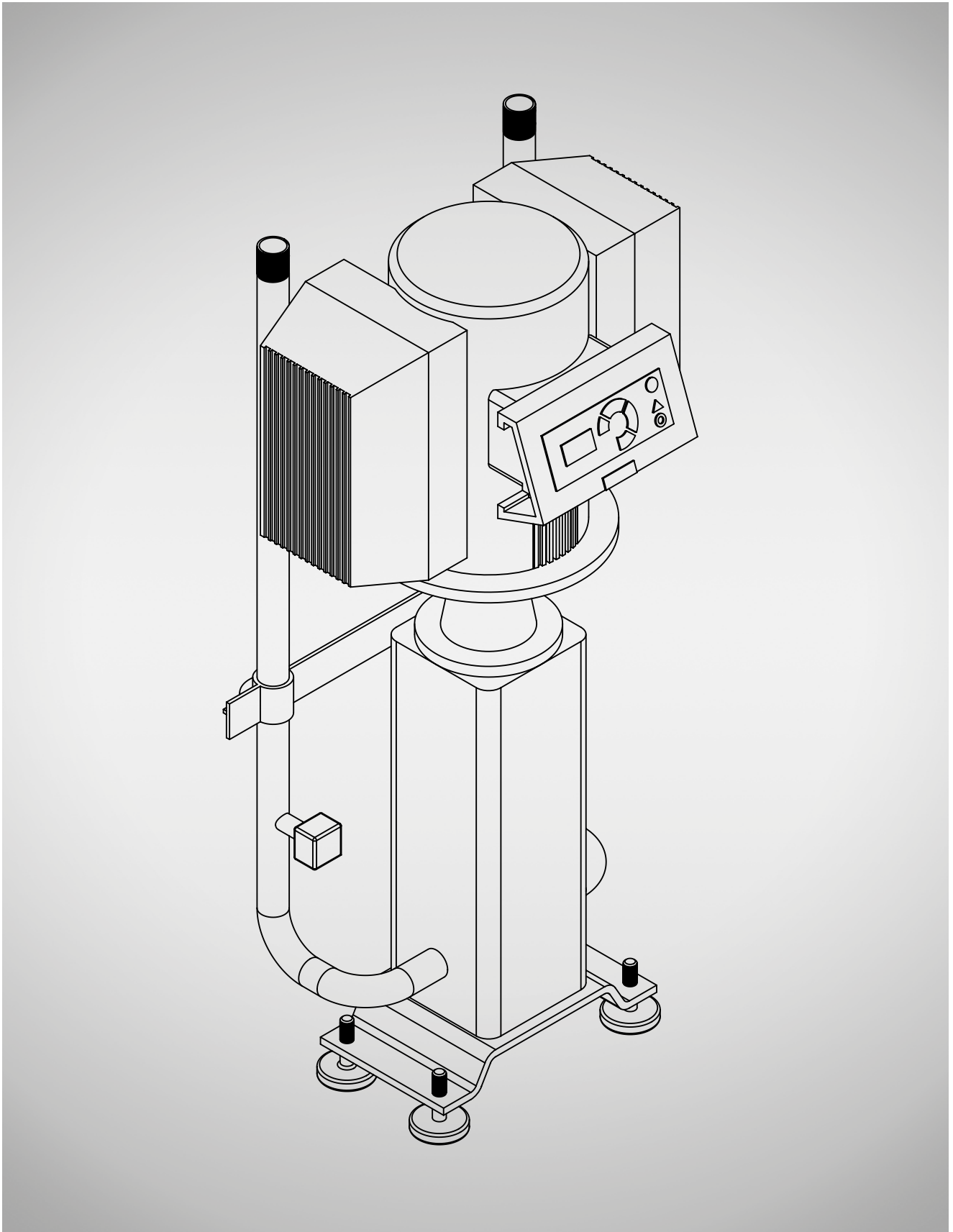

**TYPE BF, BW H**

**Stationary systems**

**ECOLAB®**



Type BF 4+



Type BW 4P

02

TYPE	ASSEMBLY	USER	POWER kW	DIMENSIONS W x D x H in mm	ARTICLE NO.
BF 4+	Status	max. 4	5.5	560 x 380 x 1200	10.10.10.00
BF 8+	Status	max. 8	11	550 x 400 x 1000	10.10.10.01
BF 162+	Status	max. 14	22	540 x 920 x 990	10.10.10.04
BW 4P	Wall	max. 4	5.5	560 x 380 x 1074	10.10.10.05
BW H4	Wall	max. 4	5.5	560 x 380 x 1074	10.10.10.02
BW H7	Wall	max. 7	11	560 x 385 x 1074	10.10.10.03

The booster supplies satellites with pressurised water. The optimal rinsing pressure for foam systems with decentralised chemical supply and minimised aerosol formation is at 25 bar. A frequency-controlled pump ensures consistent pressure reliably and user-friendly.

- Digital display with device information and operating parameters
- Infrared interface for readout and simple software update
- Adjustable outlet pressure up to 25 bar
- Pre-set dry-running protection
- Adjustable temperature monitoring
- Low-maintenance, robust, durable construction

The boosters are available in both a floor version [Type BF] and a wall version [Type BWH].

**TECHNICAL DATA**

Mains supply	3x 400 V; 50 Hz
Water supply	2 - 8 bar
Discharge Rate	120 l/min to 210 l/min
Operating pressure	25 bar

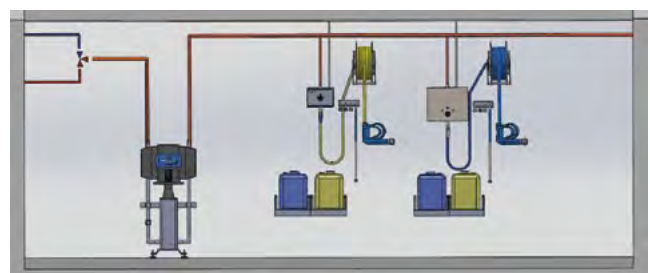

**TYPE MD, MU**

**Main, hygiene station**



Type MD 421



Type MU 422

TYPE	HOUSING	ASSEMBLY	CHEMICAL INPUTS	USER	POWER kW	FUNCTION	DIMENSIONS W x D x H in mm	ARTICLE NO.
MD 421	Plastic	Wall	2	max. 4	5.5	Rinse, 1x foaming, 1x spraying	550 x 400 x 980	10.10.10.22
MD 422	Plastic	Wall	2	max. 4	5.5	Rinsing, 2x foaming	550 x 400 x 980	10.10.10.23
MU 421	Stainless steel	Wall	2	max. 4	5.5	Rinse, 1x foaming, 1x spraying	560 x 400 x 1310	10.10.10.20
MU 422	Stainless steel	Wall	2	max. 4	5.5	Rinsing, 2x foaming	560 x 400 x 1310	10.10.10.21

**MASTER STATIONS**

Complete hygiene stations for all areas of application  
[low pressure]

The main station is a high-performance complete system for rinsing, foaming, and disinfecting, with additional features and safety functions. An integrated booster can accommodate up to 4 users at the same time.

- Digital display with device information and operating parameters
- Infrared interface for readout and simple software update
- 2 products, 1 output
- Variable pressure from 5 to max. 25 bar
- Frequency-controlled pump
- Temperature monitoring and dry-running protection

Main stations are available in several versions with ABS plastic housing [Hybrid Compact] or stainless steel housing [Hybrid] and an LCD graphic display.

**TECHNICAL DATA**

Mains supply	3x 400 V; 50 Hz
Water supply	2 - 8 bar
Discharge Rate	120 l/min to 210 l/min
Operating pressure	25 bar
Air supply	6 - 10 bar; 200 NI/min

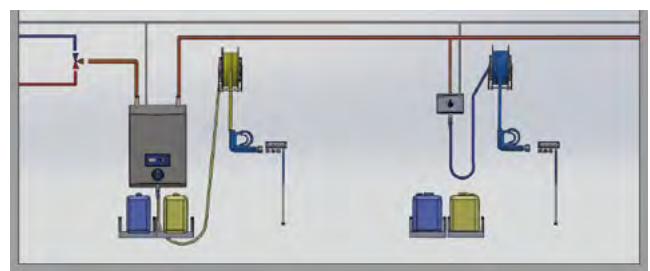

**TYPE GRIFF**

**Foam station**

**ECOLAB®**



TYPE Griff



Type Griff, inside

TYPE	HOUSING	ASSEMBLY	CHEMICAL INPUTS	USER	POWER kW	FUNCTION	DIMENSIONS W x D x H in mm	ARTICLE NO.
Griff	Plastic	Wall	2	1	0.9	Rinse, 1x foaming, 1x spraying	500 x 260 x 500	10.10.10.58

**FOAM TECHNOLOGY**

For small to medium-sized applications. [Not suitable for continuous operation! Max. 2 hours foaming possible!]

Griff is a powerful, stationary system for wall mounting for rinsing, foaming and sanitising for small to medium-sized applications. Self-sufficient with built-in compressor and durable ABS plastic cover Integrated 5.5 bar pressure boost (plus inlet pressure) and 5 bar compressor. Improved foam quality and stability. Kein Umstecken der Schläuche beim Wechsel zwischen 2 Chemieprodukten, einfache Installation, Wartung und Reinigung.

- 2 products, 1 output
- Variable pressure from 5 to max. 15 bar
- Temperature monitoring and dry-running protection

**SYSTEM CONSISTING OF:**

- Griff foam station
- Wall bracket
- Suction hose for disinfectants and detergents
- Supply hose 2.5 m
- 15 m Purflex working hose
- Foam gun
- Foam lance 100 mm
- Rinsing lance 100 mm

**TECHNICAL DATA**

Power supply	230 V; 50 Hz
Water connection	1/2" - 3/4"
Water inlet pressure	2 - 5 bar
Water outlet pressure	max. 8.5 bar
Water supply	min. 15 l/min
Water temperature	max. 70 °C
Air pressure	5 bar
Compressed air supply	23 NI/min
Hose length	max. 30 m

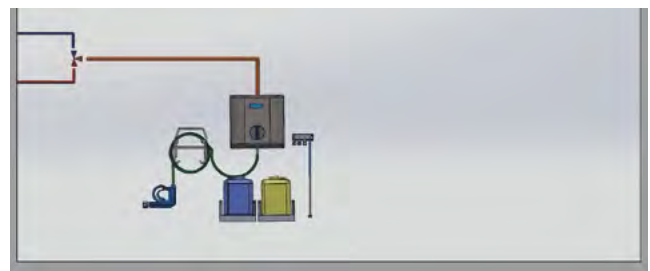

02

**TYPE SD / SU**

**Stationary systems for water pressures up to 50 bar**



Type SD 21



Type SU 22

TYPE	HOUSING	ASSEMBLY	CHEMICAL INPUTS	FUNCTION	DIMENSIONS W x D x H in mm	ARTICLE NO.
SD 21*	Plastic	Wall	2	Rinse, 1x foaming, 1x spraying	259 x 131 x 363	10.10.11.04
SD 22*	Plastic	Wall	2	Rinsing, 2x foaming	259 x 131 x 363	10.10.11.05
SD 21*	Stainless steel	Wall	2	Rinse, 1x foaming, 1x spraying	259 x 131 x 363	10.10.11.02
SD 22*	Stainless steel	Wall	2	Rinsing, 2x foaming	259 x 131 x 363	10.10.11.03
SU 21*	Stainless steel	Wall	2	Rinse, 1x foaming, 1x spraying	402 x 152 x 510	10.10.10.98
SU 22*	Stainless steel	Wall	2	Rinsing, 2x foaming	402 x 152 x 510	10.10.10.99
SU 32*	Stainless steel	Wall	3	Rinse, 2x foam, 1x spray	402 x 152 x 510	10.10.11.00
SU 33*	Stainless steel	Wall	3	Rinse, 3x foaming	402 x 152 x 510	10.10.11.01

**STATIONARY SYSTEMS, SATELLITES**

for water pressures up to 50 bar

**TYPE SD, HYBRID COMPACT**

The Hybrid Compact is a compact satellite in stainless steel or a robust ABS housing. The integrated Corona-Technology™ achieves outstanding foam quality, consistency and adhesion. Simple and effective rinsing, foaming and disinfection with up to two products via one outlet, without having to reconnect the hose. Safe operation thanks to new Duo block. Water pressure from 10 to max. 40 bar; 2 products via 1 outlet

**TYPE SU, HYBRID SATELLITE**

The Hybrid Satellite is a flexible, modularly expandable solution for all relevant applications: 2 products via 1 output, optional third product via separate output.

**TECHNICAL DATA**

Water supply	min. 10 bar / max. 40 bar
Water connection	1/2" threaded connection
Water consumption [rinsing/foaming]	up to 30 l/min - 1.2 l/min
Compressed air supply	min 6 - max 10 bar; 200 NI/ min
Air connection	Ø 6 mm



Type SD 22

\* First number [SU 33]: Number of products, second number [SU 33]: Number of foams



**TYPE YETI, SE 11**

**Stationary systems for water pressures up to 50 bar**



Type Eco SE 11



Type Yeti

02

TYPE	HOUSING	ASSEMBLY	CHEMICAL INPUTS	USER	FUNCTION	DIMENSIONS W x D x H in mm	ARTICLE NO.
Eco SE 11	Stainless steel	Wall	1	1	Rinse, 1x foaming	215 x 12 x 270	10.10.11.06
Yeti	Stainless steel	Wall	1	1	Foaming	353 x 211 x 120	10.10.10.48

**STATIONARY SYSTEMS, SATELLITES**  
for water pressures up to 50 bar

**TYPE ECO SE 11**

The ECO-Satellite SE 11 has been designed for rinsing and foaming with just a single chemical product. Compact stainless steel housing, safety through foaming and rinsing via a single outlet. Max. 25 bar water inlet pressure.

**TYPE YETI**

The Yeti is a system that, through its technology, serves to create efficient foam. Designed for heavy-duty use and durability, featuring a functional hygienic design for ease of use and stability with the new Duo-Block. Suitable for a chemical product. Low maintenance costs and easy servicing.

**TECHNICAL DATA - ECO SE 11**

Water supply	min. 12 bar / max. 25 bar
Water connection	3/4" threaded connection
Compressed air supply	min. 6-10 bar; 200 NL/min

**TECHNICAL DATA - YETI**

Water connection	1/2"
Water pressure	min. 30 bar
Water pressure	max. 80 bar
Water temperature	max. 70 °C
Compressed air supply	min. 6 - 10 bar



Type Eco SE 11



Type Yeti

**TYPE YETI / NAGA**

**Stationary systems for water pressures 2 – 8 bar**



Type NAGA



Type Yeti TW

TYPE	HOUSING	ASSEMBLY	CHEMICAL INPUTS	USER	FUNCTION	DIMENSIONS W x D x H in mm	ARTICLE NO.
Naga	Plastic	Wall	2	1	Rinse, 1x foaming, 1x spraying	225 x 125 x 280	10.10.10.55
Yeti TW	Stainless steel	Wall	1	1	Foaming	353 x 211 x 120	10.10.10.49

**STATIONARY SYSTEMS, SATELLITES**

for water pressures 2 – 8 bar

**NAGA-SATELITT**

The Naga Satellite is suitable for water pressures of 2 – 8 bar and meets the requirements for small food processing businesses seeking a reliable and smart cleaning solution that is easy to operate. The Naga is suitable for 2 chemical products via a single outlet.

The Naga includes the following accessories:

- Working hose 15 m, 3/4" with connections
- Foam lance with ball valve
- Foam nozzle and rinsing nozzle
- Hose holder, stainless steel
- Steel flex hose 2 m for water supply line
- Suction hose for cleaner incl. maximum nozzle set for chemical dosing

**YETI TW**

The Yeti is a robust foam generator made of stainless steel. Suitable for 1 chemical product. Additionally, it is easy to maintain and delivers a high-quality foam.

**TECHNICAL DATA - TYPE NAGA**

Flushing capacity at 3 bar	11 l/min
Water inlet pressure	min. 2 bar at 5.1 l/min; max. 7 bar
Inlet water temperature	up to 70°C
Water supply line	1/2" - 3/4"
Water connection	max. 15 m

**TECHNICAL DATA - TYPE YETI TW**

Water connection	1/2"
Water pressure	min. 3 bar
Compressed air supply	6 - 10 bar; 200 NI/min
Water inlet pressure	max. 7 bar
Inlet water temperature	max. 70 °C



Type NAGA



Type Yeti TW

**TYPE HT-K, HT-UP**

**Mobile foam technology**

**ECOLAB®**



Type HT-K



Type HT-K, rear

02

TYPE	HOUSING	OPERATING PRESSURE	CHEMICAL INPUTS	USER	POWER kW	FUNCTION	DIMENSIONS W x D x H in mm	ARTICLE NO.
HT-K	Stainless steel/plastic	25 bar	2	1	2.2	Rinse, 1x foaming, 1x spraying	690 x 1445 x 1030	10.10.10.50
HT-UP	Stainless steel/plastic	25 bar	2	1	2.2	Rinse, 1x foaming, 1x spraying	690 x 1445 x 1030	10.10.10.56
HT-K-40	Stainless steel/plastic	25 - 40 bar*	2	1	7.5	Rinse, 1x foaming, 1x spraying	690 x 1445 x 1030	10.10.10.51
HT-UP-40	Stainless steel/plastic	25 - 40 bar*	2	1	7.5	Rinse, 1x foaming, 1x spraying	690 x 1445 x 1030	10.10.10.57

\* Frequency-controlled pump

**MOBILE FOAM TECHNOLOGY**  
for all areas of application

**HYBRID TYPHOON**

The Hybrid Typhoon is a mobile, self-contained foam device independent of any fixed or central foam cleaning systems. The integrated pump and compressor system ensures uniform water pressure and the correct volume of compressed air for consistent foam.

- New duo block "all-in-one" output
- No need to reconnect the hose when switching between Cleaning and disinfection
- User pack version for safe handling of chemicals (optional)
- Very long service life and maximum benefit
- Rinsing, foaming and disinfecting

**ACCESSORIES FOR THE TYPHOON CAN BE FOUND ON THE FOLLOWING PAGES:**

- UHS hoses, side 176
- Couplings, page 174 f
- ZS water supply hose, side 177

**TECHNICAL DATA**

Power supply	3x 400 V; 50/60 Hz
Water connection	1/2" - 3/4"
Water inlet pressure	2 - 6 bar
Water outlet pressure	max. 25 - 40 bar
Water temperature	max. 70 °C
Flow rate	min. 15 l/min - 60 l/min
Water outlet	1/2" quick coupling
Air pressure	5 - 8 bar

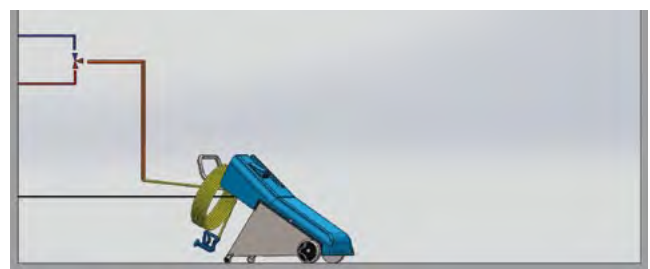

**TYPE MOBY FOAM**

**Mobile foam technology**



Type MF-37L, MF-75L



Type MF-113L

TYPE	HOUSING	MATERIAL Pumps	STORAGE TANK Unpressurised	FOAM OUTPUT	DIMENSIONS W x D x H in mm	ARTICLE NO.
MF-37L	Polyethylene	Santoprene	37 ltr.	57 - 114 l/min	400 x 480 x 1040	10.10.10.53
MF-75L	Polyethylene	Santoprene	75 ltr.	75 - 170 l/min	430 x 560 x 1200	10.10.10.52
MF-113L	Polyethylene	Santoprene	113 ltr.	75 - 170 l/min	430 x 790 x 940	10.10.10.54

**MOBILE FOAM TECHNOLOGY**

for small to medium-sized applications

MobyFoam is a foam generator for small to medium-sized applications. Practically maintenance-free, equipped with a pneumatically operated pump for foam generation. Simple operation - single adjustment knob for compressed air. Unpressurised tank enables refilling of cleaning solution during the cleaning process.

- Pneumatically operated
- Unpressurised storage tank
- Ergonomically designed
- Easy to manoeuvre
- Integrated hose holder
- Easy operation and maintenance

**TECHNICAL DATA**

Air pressure [pump]	max. 5.5 bar
Water temperature	max. 40 - 50 °C
Material trolley	Polyethylene
Working hose length	6 - 10 m
Output	Ball valve with foam lance

**TYPE GRIFF-M**

**Mobile foam technology**

**ECOLAB®**



Type Griff-M



Type Griff-M, inside

02

TYPE	HOUSING	CHEMICAL INPUTS	USER	POWER kW	FUNCTION	DIMENSIONS W x D x H in mm	ARTICLE NO.
Griff-M	Plastic	2	1	0.9	Rinse, 1x foaming, 1x spraying	500 x 260 x 500*	10.10.10.59

\*without trolley

**MOBILE FOAM TECHNOLOGY**

for small to medium-sized applications

**GRIFF-M**

Griff is a high-performance, portable foam device designed for rinsing, foaming, and disinfecting in small to medium application areas. Self-sufficient with built-in compressor, sturdy ABS cover, integrated pressure boosting and compressor. No need to reconnect the hoses when switching between 2 chemical products. Easy installation, maintenance and cleaning

**ACCESSORIES INFORMATION**

The Griff mobile consists of:

- Griff foam station
- Trolley (mobile cleaning trolley)
- Suction hose for disinfectants and detergents
- Supply hose 2.5 m
- 15 m Purflex working hose
- Foam gun - foam lance 100 mm
- Rinsing lance 100 mm

**TECHNICAL DATA**

Power supply	230 V; 50 Hz; 0.9 kW
Water connection	3/4"
Water supply	2 - 5 bar
Water outlet pressure	max. 8.5 bar
Water supply	min. 15 l/min
Water temperature	max. 70 °C
Air pressure	5 bar
Compressed air supply	23 NI/min
Max. Hose length	30 m



**TYPE ST**

**Foam/water guns**

STAINLESS STEEL 1.4301



Type ST 2700



Type ST 2720



Type ST 3100

TYPE	MATERIAL Valve housing	PRESSURE max. permissible	TEMPERATURE	FLOW VOLUME	CONNECTION Input	CONNECTION Output	ARTICLE NO.
ST 2700	Stainless steel	310 bar	150 °C	45 l/min	3/8" IG	1/4" IG	10.71.23.61
ST 2720	Stainless steel	125 bar	150 °C	80 l/min	1/2" IG	3/8" IG	10.71.23.62
ST 3100	Stainless steel	60 bar	150 °C	100 l/min	1/2" IG	3/8" IG	10.71.23.63

**TYPE ST 2700**

Foam gun with swivel joint - Plastic-coated gun for industrial applications. Made from food-safe plastics in accordance with Directive 1935/2004/EC. Particularly suitable for the food industry.

**TYPE ST 2720**

Foam gun - Plastic coated gun for industrial applications.

Valve material: Stainless steel/PEEK - with LTF technology [Low Trigger Force] - suitable for foodstuffs - suitable for low pressure due to PEEK sealing cone.

**TYPE ST 3100**

Foam gun with wDamper Stainless steel - plastic coated Gun for industrial applications.

Valve material: PTFE/ stainless steel - switch-off delay by means of integrated damper.

**TYPE WP**

**Water gun**

STAINLESS STEEL 1.4301



- Water gun Type WP stainless steel
- Rubber-coated gun for industrial applications with stepless spray angle adjustment
- Volume flow 100 l/min

TYPE	MATERIAL Housing	PRESSURE max. permissible	TEMPERATURE	CONNECTION Input	ARTICLE NO.
WP	Stainless steel	24 bar	50 °C	1/2" IG	10.71.23.60



**TYPE ST 3225 ERGO**

## Foam, water gun

STAINLESS STEEL 1.4301



- Foam gun Specially for the highest hygiene requirements and ergonomics Stainless steel
- Switch-off delay by means of integrated damper (stainless steel)
- Valve material: PTFE, stainless steel - with LTF technology [Low Trigger Force]
- Suitable for foodstuffs according to Directive 1935/2004/EC

TYPE	MATERIAL Valve housing	PRESSURE max. permissible	TEMPERATURE	FLOW VOLUME	CONNECTION Input	CONNECTION Output	ARTICLE NO.
ST 3225 Ergo	Stainless steel	60 bar	100 °C	120 l/min	1/2" IG	1/2" IG	10.71.23.64

02

**TYPE JET**

## Air, water gun

STAINLESS STEEL 1.4301



- Gun suitable for cleaning soiled small parts
- Connection nipple for compressed air and water (2x 10 mm)
- Brass hose connection, plastic nozzle
- Non-slip, rubber-coated handle
- Without air or water hose

TYPE	VERSION	ARTICLE NO.
WP	Air and water connection	12.00.00.71

**TYPE DG-360°**

## Swivel joint

STAINLESS STEEL 1.4301



Swivel joint 360° 1/2" IG/AG

TYPE	PRESSURE max. permissible	TEMPERATURE	CONNECTION Input	CONNECTION Output	ARTICLE NO.
DG- 360°	60 bar	150 °C	1/2" IG	1/2" AG	10.71.23.53

**TYPE SKW**

## Quick coupling

PLASTIC, STAINLESS STEEL 1.4301



Quick coupling Type SKW V2A 3/8" with plastic protection for water guns ST2700, ST3100, ST2720 [protection available in other colours]

TYPE	PRESSURE max. permissible	TEMPERATURE	CONNECTION Input	CONNECTION Output	ARTICLE NO.
SKW-I	250 bar	90 °C	3/8" AG	Coupling for nozzles, lances	10.71.23.58
SKW-II	250 bar	90 °C	1/2" AG	Coupling for nozzles, lances	10.71.23.59
SKW-III	250 bar	90 °C	1/4" AG	Coupling for nozzles, lances	10.71.23.65

**TYPE SV-AG**

## Hose connectors

STAINLESS STEEL 1.4301



Hose connectors 1/2" to 3/4" with AG 1/2"

TYPE	PRESSURE max. permissible	TEMPERATURE	CONNECTION Input	CONNECTION Output	ARTICLE NO.
SV-AG	250 bar	90 °C	1/2" - 3/4"	1/2" AG	10.71.23.52

**TYPE KS**

## Coupling plug

STAINLESS STEEL 1.4301



Coupling plug Type KS 1/2" IG

TYPE	PRESSURE max. permissible	TEMPERATURE	CONNECTION Input	CONNECTION Output	ARTICLE NO.
KS 1/2" IG	250 bar	90 °C	1/2" IG	Plug	10.71.23.54



Coupling plug Type KS 1/2" AG

TYPE	PRESSURE max. permissible	TEMPERATURE	CONNECTION Input	CONNECTION Output	ARTICLE NO.
KS 1/2" AG	250 bar	90 °C	1/2" AG	Plug	10.71.23.55

02

**TYPE SK**

## Quick coupling

STAINLESS STEEL 1.4301

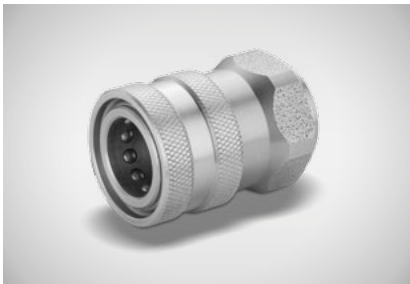

Quick coupling Type SK 1/2" IG

TYPE	PRESSURE max. permissible	TEMPERATURE	CONNECTION Input	CONNECTION Output	ARTICLE NO.
SK 1/2" IG	250 bar	90 °C	1/2" IG	Coupling for plug	10.71.23.56



Quick coupling Type SK 1/2" AG

TYPE	PRESSURE max. permissible	TEMPERATURE	CONNECTION Input	CONNECTION Output	ARTICLE NO.
SK 1/2" AG	250 bar	90 °C	1/2" AG	Coupling for plug	10.71.23.57

**TYPE UHS**

# Hygiene hoses

OUTER LAYER PVC, STAINLESS STEEL 1.4301



Type UHS-B



Green



Yellow



Red

TYPE	LENGTH	COLOUR	PRESSURE max. permissible	TEMPERATURE RANGE	GROUTING both sides	INPUT	OUTPUT	ARTICLE NO.
UHS-B 20M	20 m	blue	50 bar	from -10 °C to +70 °C	Stainless steel sleeves	1/2" AG	1/2" AG	10.71.23.42
UHS-B 25M	25 m	blue	50 bar	from -10 °C to +70 °C	Stainless steel sleeves	1/2" AG	1/2" AG	10.71.23.43
UHS-B 30M	30 m	blue	50 bar	from -10 °C to +70 °C	Stainless steel sleeves	1/2" AG	1/2" AG	10.71.23.44
UHS-Y 20M	20 m	yellow	50 bar	from -10 °C to +70 °C	Stainless steel sleeves	1/2" AG	1/2" AG	10.71.23.45
UHS-Y 25M	25 m	yellow	50 bar	from -10 °C to +70 °C	Stainless steel sleeves	1/2" AG	1/2" AG	10.71.23.46
UHS-Y 30M	30 m	yellow	50 bar	from -10 °C to +70 °C	Stainless steel sleeves	1/2" AG	1/2" AG	10.71.23.47
UHS-G 20M	20 m	green	50 bar	from -10 °C to +70 °C	Stainless steel sleeves	1/2" AG	1/2" AG	10.71.23.48
UHS-G 25M	25 m	green	50 bar	from -10 °C to +70 °C	Stainless steel sleeves	1/2" AG	1/2" AG	10.71.23.49
UHS-G 30M	30 m	green	50 bar	from -10 °C to +70 °C	Stainless steel sleeves	1/2" AG	1/2" AG	10.71.23.36
UHS-R 20M	20 m	red	50 bar	from -10 °C to +70 °C	Stainless steel sleeves	1/2" AG	1/2" AG	10.71.23.37
UHS-R 25M	25 m	red	50 bar	from -10 °C to +70 °C	Stainless steel sleeves	1/2" AG	1/2" AG	10.71.23.38
UHS-R 30M	30 m	red	50 bar	from -10 °C to +70 °C	Stainless steel sleeves	1/2" AG	1/2" AG	10.71.23.39

**TYPE UHS**

The Ultra hygiene hoses Type UHS comply with the requirements of EC 1935/2004 and 10/2011 and are equipped with a homogeneous, non-porous, flexible, grey inner layer - absolutely odourless and tasteless.

The print carrier is made of synthetic yarns and Teflon. The PVC outer layer is resistant to chemicals, abrasion, UV, grease and oil.

**TYPE VSA**

## Connecting hose

OUTER LAYER PVC, STAINLESS STEEL 1.4301



Blue

Connecting hose Type VSA reel to satellite.  
Also available in other colours (green, yellow, red).



Yellow

TYPE	LENGTH	COLOUR	PRESSURE max. permissible	TEMPERATURE RANGE	GROUTING both sides	INPUT	OUTPUT	ARTICLE NO.
VSA-3M	3 m	blue	50 bar	from -10 °C to +70 °C	Stainless steel sleeves	1/2" AG	1/2" socket	10.71.23.40
VSA-1,5M	1.5 m	blue	50 bar	from -10 °C to +70 °C	Stainless steel sleeves	1/2" AG	1/2" socket	10.71.23.41

**TYPE ZS**

## Supply hose

OUTER LAYER PVC, STAINLESS STEEL 1.4301



Feed hose Type ZS 3/4" for mobile systems  
(e.g. Typhoon and Griff) - incl. connection fittings.

TYPE	LENGTH	COLOUR	PRESSURE max. permissible	INPUT	OUTPUT	ARTICLE NO.
ZS-5M	5 m	yellow	15 bar	Nito coupling	GEKA coupling	10.10.12.16
ZS-10M	10 m	yellow	15 bar	Nito coupling	GEKA coupling	10.10.12.18

**TYPE WD, SD, SL, DD**

**Water, foam and disinfection nozzles**

PLASTIC, STAINLESS STEEL 1.4301



Type SD



Type WD



TYPE DD

TYPE	COLOUR Plastic protection	LENGTH in mm	SPRAY ANGLE	OUTPUT at 20 bar	INPUT	ARTICLE NO.
WD-25/30	blue	70	25°	30 l/min	Quick connector	10.71.23.70
WD-25/15 Economy nozzle	blue	70	25°	15 l/min	Quick connector	10.71.23.71
WD-00/25 point nozzle	green	70	0°	25 l/min	Quick connector	10.71.23.72
SD-50/200	white	70	50°	200 l/min	Quick connector	10.71.23.73
SL-50/200	white	220	50	200 l/min	Quick connector	10.71.23.74
DD-15/15	yellow	70	15°	15 l/min	Quick connector	10.71.23.75
DD-20/15	yellow	70	20°	15 l/min	Quick connector	10.71.23.76
Top-Jet	blue/white	120	50°	25 l/min	Quick coupling	10.71.23.99

**TYPE SD, SL, TOP-JET**

Foam nozzles with plastic protection made of 1.4301 stainless steel.



Type SL

**TYPE WD**

Water nozzles with plastic protection made of stainless steel 1.4301, also available in other spray angles on request, water volume l/min.



Type Top-Jet (max. 2 - 8 bar; 60 °C)

**TYPE DD**

Disinfectant nozzles with plastic protection made of stainless steel 1.4301, also available in other spray angles on request, water volume l/min.

Foam lances V2A can also be ordered in other lengths on request up to a maximum length of 2,500 mm.



**TYPE NOZZLE SET**

## Nozzle set

PLASTIC, STAINLESS STEEL 1.4301



Nozzle set No.3 with plastic protection made of stainless steel 1.4301, also available in other spray angles on request, water volume l/min. Includes wall bracket for 4 positions.

TYPE NOZZLE SET consisting of	COLOUR Plastic protection	LENGTH mm	SPRAY ANGLE	OUTPUT at 20 bar	INPUT	ARTICLE NO. for the set
WD-00/20	green	70	0°	20 l/min	Quick connector	10.71.23.77
WL-25/30	blue	500	25°	30 l/min	Quick connector	
DD-15/15	yellow	70	15°	15 l/min	Quick connector	
SD-50/200	white	70	50°	200 l/min	Quick connector	

**TYPE WL**

## Water lances

PLASTIC, STAINLESS STEEL 1.4301



Water lances with plastic protection made of stainless steel 1.4301, also available in other spray angles on request, water volume l/min.

V2A water lances can also be ordered in other lengths, up to a maximum length of 4,000 mm on request.

TYPE	COLOUR Plastic protection	LENGTH mm	SPRAY ANGLE	OUTPUT at 20 bar	INPUT	ARTICLE NO.
WL-25/30	blue	700	25°	30 l/min	Quick connector	10.71.23.78

**TYPE WH**

## Wall bracket

STAINLESS STEEL 1.4301



- Wall bracket for 4 stainless steel nozzles or lances stainless steel 1.4301
- Easy assembly

TYPE	POSITIONS	ARTICLE NO.
WH-4	up to 4 pieces	10.71.23.79

**TYPE SAR**

## Automatic hose rewriter

STAINLESS STEEL 1.4301



Type SAR 20M



Type SAR 35M



Type SAR-H 25M

TYPE	HOSE HOLDER	SWIVEL JOINT	OPERATING PRES-SURE	OUTPUT	INPUT	DIMENSIONS W x D x H in mm	ARTICLE NO.
SAR 20M	max. 20 m, 1/2"	yes	max. 100 bar	1/2" IG	1/2" AG	235 x 430 x 560	10.71.23.20
SAR 25M	max. 25 m, 1/2"	yes	max. 100 bar	1/2" IG	1/2" AG	310 x 550 x 550	10.71.23.25
SAR 35M	max. 35 m, 1/2"	yes	max. 100 bar	1/2" IG	1/2" AG	310 x 550 x 560	10.71.23.35
SAR-H 25M	max. 25 m, 1/2"	yes	max. 100 bar	1/2" IG	1/2" AG	555 x 480 x 555	10.10.12.00

**TYPE WSK**

## Wall slewing console

STAINLESS STEEL 1.4301

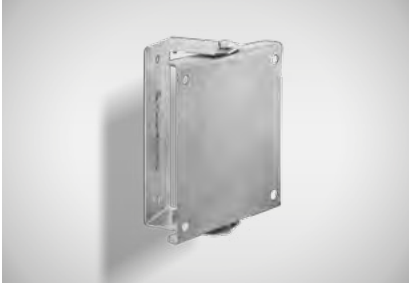

- Stainless steel wall brackets
- a counter plate is recommended for lightweight walls

TYPE	FOR HOSE REELS	SWIVELLING RANGE	DIMENSIONS W x D x H in mm	ARTICLE NO.
WSK 20M	up to 20 m	180°	210 x 12 x 300	10.71.23.50



TYPE	FOR HOSE REELS	SWIVELLING RANGE	DIMENSIONS W x D x H in mm	ARTICLE NO.
WSK 25-35M	up to 35 m	180°	320 x 190 x 400	10.71.23.51

**TYPE SH-G**

## Hose bracket

STAINLESS STEEL 1.4301

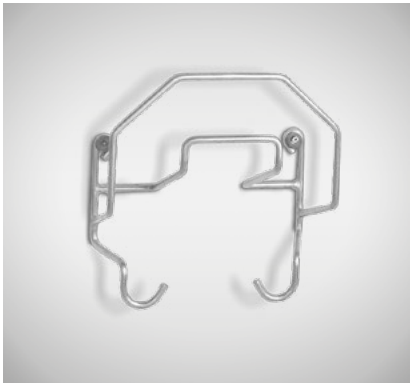

- For wall mounting
- Robust design
- For various types of hose rewinders
- 2 mountings for hygiene accessories

TYPE	DIMENSIONS W x D x H in mm	ARTICLE NO.
SH-G	300 x 160 x 310	18.00.02.77

**TYPE KHD**

## Universal angle bracket

STAINLESS STEEL 1.4301



- For wall mounting
- Robust design
- For various types of hose rewinders

TYPE	DIMENSIONS W x D x H in mm	ARTICLE NO.
KHD	210 x 390 x 330	10.71.02.01

**TYPE USF**

## Universal hose guide

STAINLESS STEEL 1.4301



- Hose guide for universal application

TYPE	DIMENSIONS W x D x H in mm	ARTICLE NO.
USF	103 x 91 x 124	10.71.01.20

**OPTION**

Angle profile "corner solution"	Article no. 10.71.01.21
---------------------------------	-------------------------

**TYPE KB HIGHLINE**

## Can container, lockable



- Optimum and safe storage from chemicals
- Hygienic-Design
- Loss and theft protection
- Recess in the container and lid for suction hose
- Base with drainage holes

TYPE	CAPACITY	VERSION	DIMENSIONS W x D x H in mm	ARTICLE NO.
KB-ESV	1 x 24 kg	Status	295 x 290 x 630	16.10.02.01
KB-EWV	1 x 24 kg	Wall	295 x 290 x 550	16.10.02.02
KB-DSV	2 x 24 kg	Status	510 x 290 x 630	16.10.02.03
KB-DWV	2 x 24 kg	Wall	510 x 290 x 550	16.10.02.04

**TYPE KH**

## Can holder



- Open
- Wall-mounted version
- Hygienic-Design
- Stainless steel sheet with draining hole
- With hygienic corner recesses

TYPE	CAPACITY	DIMENSIONS W x D x H in mm	ARTICLE NO.
KH-II	1 x 10 kg	250 x 210 x 200	16.10.00.02
KH-III	1 x 24 kg	350 x 260 x 200	16.10.00.08
KH-VI	2x 10 kg	350 x 255 x 200	16.10.00.16

**TYPE KB HIGHLINE**

## Can container, lockable



- Optimum and safe storage from chemicals
- Housing cover with sturdy handle, Rotary bolt lock and bar locking
- Base with drainage holes

TYPE	CAPACITY	VERSION	DIMENSIONS W x D x H in mm	ARTICLE NO.
KB-ESA	1 x 24 kg	Status	295 x 290x 630	16.10.01.01
KB-EWA	2 x 24 kg	Wall	295 x 290x 550	16.10.01.02
KB-DSA	2 x 24 kg	Status	510 x 290 x 630	16.10.01.03
KB-DWA	2 x 24 kg	Wall	510 x 290 x 550	16.10.01.04

**TYPE KH-CA**

## Can holder



- Secure locking system without padlocks and other dangerous parts
- Clear instructions next to the lock
- Wall-mounted
- Master key system

TYPE	CAPACITY	VERSION	DIMENSIONS W x D x H in mm	ARTICLE NO.
KH-CA I	1 x 24 kg	Wall	275 x 365 x 495	05.04.00.03
KH-CA II	2 x 24 kg	Wall	545 x 365 x 495	05.04.00.04

3

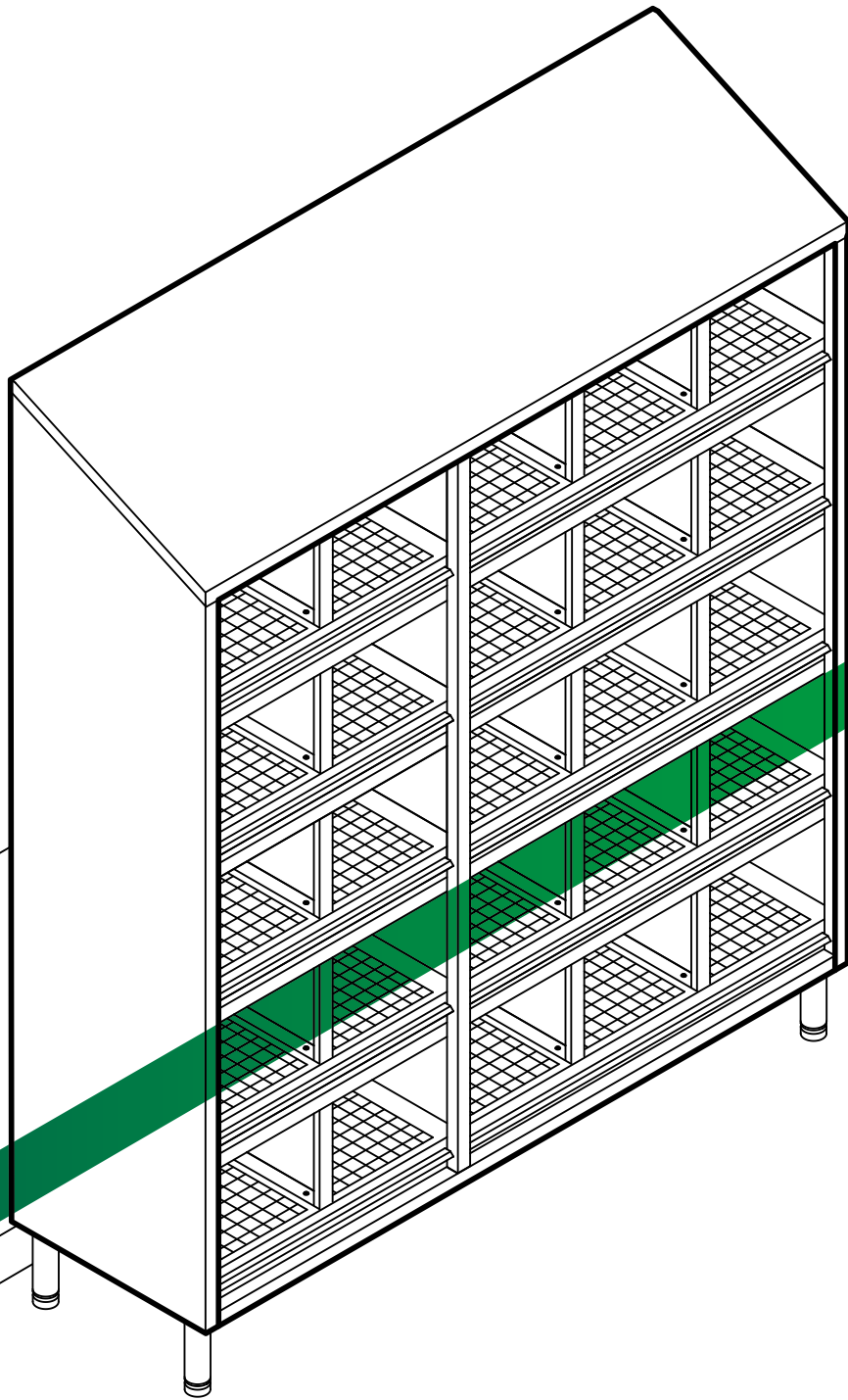



# 03

## SOCIAL AREA EQUIPMENT

Wardrobe cabinets, single and two-storey

---

Wardrobe cabinets, Z-shape

---

Space-saving cabinets

---

Small compartment cabinets

---

Compartment cabinets closed

---

Compartment cabinets open

---

Laundry dispensing cabinets

---

Laundry collector cabinets

---

Benches and changeover benches

---

**TYPE GS1**  
**Lockers**



Version: with feet, steel [ST], Article no. 45.00.01.07

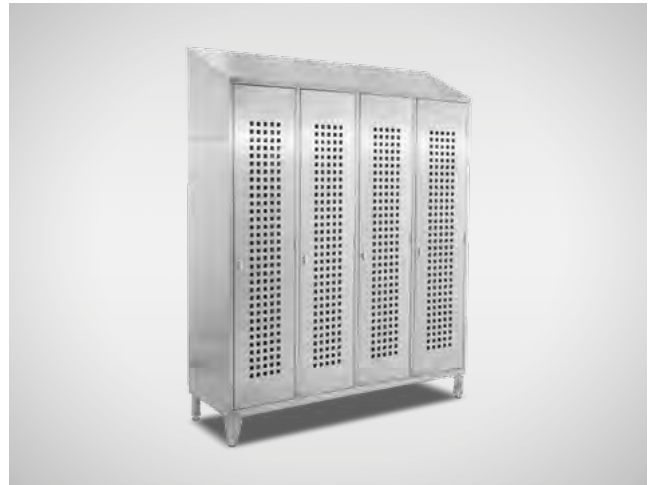

Version: with feet, stainless steel [VA], Article no. 45.10.01.07

**Wall-mounted D: 500 mm**



	1 BLOCK		2 BLOCKS	
	320	420	610	810
<b>WIDTH</b>				
<b>HEIGHT</b>	1700/1900	1700/1900	1700/1900	1700/1900
<b>COMP.</b>	1x 300	1x 400	2x 300	2x 400
<b>ART. NO. ST</b>	45.00.00.60	45.00.00.61	45.00.00.62	45.00.00.63
<b>ART. NO. VA</b>	45.10.00.60	45.10.00.61	45.10.00.62	45.10.00.63

**With feet<sup>1</sup> D: 500 mm**



	1 BLOCK		2 BLOCKS	
	320	420	610	810
<b>WIDTH</b>				
<b>HEIGHT</b>	1850/2050	1850/2050	1850/2050	1850/2050
<b>COMP.</b>	1x 300	1x 400	2x 300	2x 400
<b>ART. NO. ST</b>	45.00.01.00	45.00.01.01	45.00.01.02	45.00.01.03
<b>ART. NO. VA</b>	45.10.01.00	45.10.01.01	45.10.01.02	45.10.01.03

**With base frame<sup>2</sup> D: 500 mm**



	1 BLOCK		2 BLOCKS	
	320	420	610	810
<b>WIDTH</b>				
<b>HEIGHT</b>	2090/2290	2090/2290	2090/2290	2090/2290
<b>COMP.</b>	1x 300	1x 400	2x 300	2x 400
<b>ART. NO. ST</b>	45.00.00.70	45.00.00.71	45.00.00.72	45.00.00.73
<b>ART. NO. VA</b>	45.10.00.70	45.10.00.71	45.10.00.72	45.10.00.73

**With bench D: 500/815 mm**



	1 BLOCK		2 BLOCKS	
	320	420	610	810
<b>WIDTH</b>				
<b>HEIGHT</b>	2090/2290	2090/2290	2090/2290	2090/2290
<b>COMP.</b>	1x 300	1x 400	2x 300	2x 400
<b>ART. NO. ST</b>	45.00.00.10	45.00.00.11	45.00.00.12	45.00.00.13
<b>ART. NO. VA</b>	45.10.00.10	45.10.00.11	45.10.00.12	45.10.00.13

Cabinet with 300 compartment width and self-ventilation concept in accordance with EU Directive & §34 Workplace Ordinance!

- Integrated pitched roof [200 mm higher at the back]
- Outside of the door with imprint for name plate
- Doors perforated [square perforation]  
Hole pattern beginning underneath the hat shelf > private area!
- Right hinged doors, mounted on pivot pins
- Twist-lock catch for padlock [on the part of the building site]
- Every compartment with hat shelf, clothes rail + 3 slide bars
- Smooth shelf with ventilation holes
- Lower structure as wall-mounted, on feet, with elevated base frame or with bench mounted below

**Note:** Wardrobe lockers with a compartment width of 400 mm are equipped with a centre partition and do not comply with the Workplace Ordinance!

**BODY AND DOOR COLOURS**

You can find all colour variants on Page 202

**OPTIONS VARIANTS WITH UNDERFRAME OR BENCH**

Shoe tray for 300 mm compartment width, steel [ST]	Article no. 80.50.70.10
Shoe tray for 400 mm compartment width, steel [ST]	Article no. 80.52.70.10
Shoe tray for 300 mm compartment width, stainless steel [VA]	Article no. 45.10.70.10
Shoe tray for 400 mm compartment width, stainless steel [VA]	Article no. 45.12.70.10
Additional options	see page 203

3 BLOCKS	
900	1200
1700/1900	1700/1900
3x 300	3x 400
45.00.00.64	45.00.00.65
45.10.00.64	45.10.00.65

4 BLOCKS	
1190	1590
1700/1900	1700/1900
4x 300	4x 400
45.00.00.66	45.00.00.67
45.10.00.66	45.10.00.67

5 BLOCKS
1480
1700/1900
5x 300
45.00.00.68
45.10.00.68

3 BLOCKS	
900	1200
1850/2050	1850/2050
3x 300	3x 400
45.00.01.04	45.00.01.05
45.10.01.04	45.10.01.05

4 BLOCKS	
1190	1590
1850/2050	1850/2050
4x 300	4x 400
45.00.01.06	45.00.01.07
45.10.01.06	45.10.01.07

5 BLOCKS
1480
1850/2050
5x 300
45.00.01.08
45.10.01.08

3 BLOCKS	
900	1200
2090/2290	2090/2290
3x 300	3x 400
45.00.00.74	45.00.00.75
45.10.00.74	45.10.00.75

4 BLOCKS	
1190	1590
2090/2290	2090/2290
4x 300	4x 400
45.00.00.76	45.00.00.77
45.10.00.76	45.10.00.77

5 BLOCKS
1480
2090/2290
5x 300
45.00.00.78
45.10.00.78

3 BLOCKS	
900	1200
2090/2290	2090/2290
3x 300	3x 400
45.00.00.14	45.00.00.15
45.10.00.14	45.10.00.15

4 BLOCKS	
1190	1590
2090/2290	2090/2290
4x 300	4x 400
45.00.00.16	45.00.00.17
45.10.00.16	45.10.00.17

5 BLOCKS
1480
2090/2290
5x 300
45.00.00.18
45.10.00.18

<sup>1</sup> Version with feet  
ST [steel]: none  
Height adjustment.  
Remaining versions:  
incl. height adjustment:  
+/- 15 mm

<sup>2</sup> Picture shows:  
Option with shoe rack

ST = Steel  
VA = Stainless steel

**TYPE GS2**

# Lockers, two-storey



Version: with bench, steel [ST], Article no. 45.00.04.36

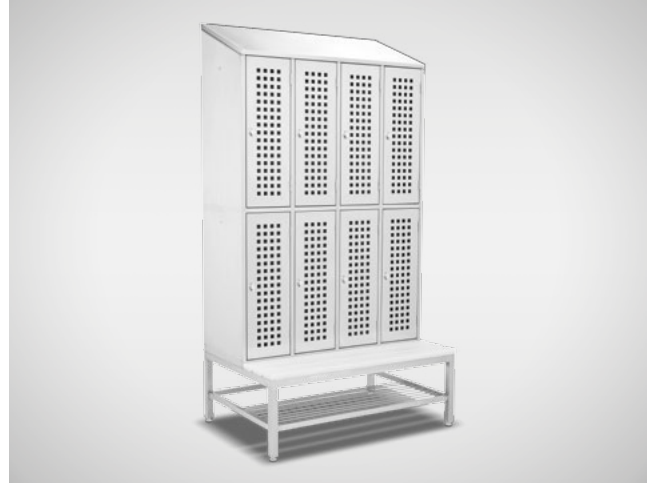

Version: with bench and optional shoe rack, stainless steel [VA], Article no. 45.10.04.36

**Wall-mounted D: 500 mm**



	1 BLOCK		2 BLOCKS	
WIDTH	320	420	610	810
HEIGHT	1700/1900	1700/1900	1700/1900	1700/1900
COMP.	1x 300	1x 400	2x 300	2x 400
ART. NO. ST	45.00.04.00 <sup>2</sup>	45.00.04.01 <sup>2</sup>	45.00.04.02	45.00.04.03
ART. NO. VA	45.10.04.00	45.10.04.01	45.10.04.02	45.10.04.03

**With feet<sup>1</sup> D: 500 mm**



	1 BLOCK		2 BLOCKS	
WIDTH	320	420	610	810
HEIGHT	1850/2050	1850/2050	1850/2050	1850/2050
COMP.	1x 300	1x 400	2x 300	2x 400
ART. NO. ST	45.00.04.10 <sup>2</sup>	45.00.04.11 <sup>2</sup>	45.00.04.12	45.00.04.13
ART. NO. VA	45.10.04.10	45.10.04.11	45.10.04.12	45.10.04.13

**With base frame<sup>3</sup> D: 500 mm**



	1 BLOCK		2 BLOCKS	
WIDTH	320	420	610	810
HEIGHT	2090/2290	2090/2290	2090/2290	2090/2290
COMP.	1x 300	1x 400	2x 300	2x 400
ART. NO. ST	45.00.04.20 <sup>2</sup>	45.00.04.21 <sup>2</sup>	45.00.04.22	45.00.04.23
ART. NO. VA	45.10.04.20	45.10.04.21	45.10.04.22	45.10.04.23

**With bench D: 500/815 mm**



	1 BLOCK		2 BLOCKS	
WIDTH	320	420	610	810
HEIGHT	2090/2290	2090/2290	2090/2290	2090/2290
COMP.	1x 300	1x 400	2x 300	2x 400
ART. NO. ST	45.00.04.30 <sup>2</sup>	45.00.04.31 <sup>2</sup>	45.00.04.32	45.00.04.33
ART. NO. VA	45.10.04.30	45.10.04.31	45.10.04.32	45.10.04.33

**Cabinet with integrated self-ventilation concept in accordance with EU Directive and § 34 Workplace Regulations!**

- Two-storey version = 2 overlying  
Compartments or doors per compartment
- Door clear dimension: W: 230/330 x D: 465 x H: 786 mm
- Outside of the door with imprint for name plate
- Doors perforated [square perforation]
- Right hinged doors, mounted on pivot pins
- Twist-lock catch for padlock (on the part of the building site)
- Every shelf with clothes rail + 3 slide bars
- Integrated pitched roof [200 mm higher at the back]
- Lower structure as wall-mounted, on feet, with elevated base frame or with bench mounted below

**BODY AND DOOR COLOURS**

You can find all colour variants on Page 202

**OPTIONS VARIANTS WITH UNDERFRAME OR BENCH**

Shoe tray for 300 mm compartment width, steel [ST]	Article no. 80.50.70.10
Shoe tray for 400 mm compartment width, steel [ST]	Article no. 80.52.70.10
Shoe tray for 300 mm compartment width, stainless steel [VA]	Article no. 45.10.70.10
Shoe tray for 400 mm compartment width, stainless steel [VA]	Article no. 45.12.70.10
Additional options	see page 203

3 BLOCKS	
900	1200
1700/1900	1700/1900
3x 300	3x 400
45.00.04.04	45.00.04.05
45.10.04.04	45.10.04.05

4 BLOCKS	
1190	1590
1700/1900	1700/1900
4x 300	4x 400
45.00.04.06	45.00.04.07
45.10.04.06	45.10.04.07

3 BLOCKS	
900	1200
1850/2050	1850/2050
3x 300	3x 400
45.00.04.14	45.00.04.15
45.10.04.14	45.10.04.15

4 BLOCKS	
1190	1590
1850/2050	1850/2050
4x 300	4x 400
45.00.04.16	45.00.04.17
45.10.04.16	45.10.04.17

3 BLOCKS	
900	1200
2090/2290	2090/2290
3x 300	3x 400
45.00.04.24	45.00.04.25
45.10.04.24	45.10.04.25

4 BLOCKS	
1190	1590
2090/2290	2090/2290
4x 300	4x 400
45.00.04.26	45.00.04.27
45.10.04.26	45.10.04.27

3 BLOCKS	
900	1200
2090/2290	2090/2290
3x 300	3x 400
45.00.04.34	45.00.04.35
45.10.04.34	45.10.04.35

4 BLOCKS	
1190	1590
2090/2290	2090/2290
4x 300	4x 400
45.00.04.36	45.00.04.37
45.10.04.36	45.10.04.37

<sup>1</sup> Version with feet  
ST [steel]: none  
Height adjustment.  
Remaining versions:  
incl. height adjustment:  
+/- 15 mm

<sup>2</sup> on request

<sup>3</sup> Picture shows:  
Option with shoe rack

ST = Steel  
VA = Stainless steel

**TYPE GSZ**  
**Lockers Z-shape**

STEEL / STAINLESS STEEL 1.4301



Version: with feet, steel [ST], Article no. 45.00.07.03



Version: with feet, stainless steel [VA], Article no. 45.10.07.53

**Wall-mounted** D: 510 mm



	1 BLOCK	2 BLOCKS
<b>WIDTH</b>	420	810
<b>HEIGHT</b>	1700/1930	1700/1930
<b>COMP.</b>	1x 400	2x 400
<b>ART. NO. ST</b>	45.00.07.00	45.00.07.01
<b>ART. NO. VA</b>	45.10.07.00	45.10.07.01

**With feet** D: 510 mm



	1 BLOCK	2 BLOCKS
<b>WIDTH</b>	420	810
<b>HEIGHT</b>	1850/2080	1850/2080
<b>COMP.</b>	1x 400	2x 400
<b>ART. NO. ST</b>	45.00.07.02	45.00.07.03
<b>ART. NO. VA</b>	45.10.07.02	45.10.07.03

**With base frame** D: 510 mm



	1 BLOCK	2 BLOCKS
<b>WIDTH</b>	420	810
<b>HEIGHT</b>	2090/2310	2090/2310
<b>COMP.</b>	1x 400	2x 400
<b>ART. NO. ST</b>	45.00.07.04	45.00.07.05
<b>ART. NO. VA</b>	45.10.07.04	45.10.07.05

**With bench** D: 510/825 mm



	1 BLOCK	2 BLOCKS
<b>WIDTH</b>	420	810
<b>HEIGHT</b>	2090/2310	2090/2310
<b>COMP.</b>	1x 400	2x 400
<b>ART. NO. ST</b>	45.00.07.06	45.00.07.07
<b>ART. NO. VA</b>	45.10.07.06	45.10.07.07

**SPACE-SAVING CABINET IN Z-SHAPE**

- Each compartment with 2 doors in Z-shape
- Clear measure per compartment:
  - > W: 160/350 x D: 480 x H: 1,225 mm
  - > Height of the wide area H: 340 mm
- With pitched roof, 230 mm higher at the rear
  - > ST [Steel]: attachment
  - > VA [stainless steel]: integrated
- Doors perforated [square perforation]
- Twist-lock catch for padlock [on the part of the building site]
- Every compartment with 3 hooks
- Rear wall with ventilation holes
- Lower structure as wall-mounted, on feet, with elevated base frame or with bench mounted below

**BODY AND DOOR COLOURS**

You can find all colour variants on page 202

**OPTIONS**

Shoe tray for compartment width 400 mm, steel [ST] Article no. 80.52.70.10

Shoe tray for compartment width 400 mm, stainless steel [VA] Article no. 45.12.70.10

Additional options see page 203

ST = Steel  
VA = Stainless steel



**TYPE RSG**

## Space-saving clothes cabinet

STAINLESS STEEL 1.4301



Version: 6-unit block, steel [VA], article no. 18.17.06.02

- Depth 500 mm, compartment width 150 mm
- Integrated pitched roof [200 mm higher at the back]
- Outside with embossing for name plate
- Right hinged doors
- With cylinder lock per door
- Each compartment with hat shelf, clothes rail and 3 sliding hooks
- Smooth shelf with ventilation holes
- Lower structure on feet
- Ground clearance: 150 mm

**OPTIONS**

Options see page 203

	4 BLOCKS	6 BLOCKS	8 BLOCKS
<b>WIDTH</b>	620	920	1220
<b>HEIGHT</b>	1850/2050	1850/2050	1850/2050
<b>COMP.</b>	4	6	8
<b>ART. NO. VA</b>	18.17.04.02	18.17.06.02	18.17.08.02

03

**TYPE KGS**

## Small compartment cabinets

STAINLESS STEEL 1.4301



Version: Stainless steel [VA]

- Available with 30 or 40 compartments
- Depth 200 mm
- Cabinet with 2 compartments, each with 15 or 20 tiers of compartments stacked vertically
- Section width: 200 mm
- Integrated pitched roof [200 mm higher at the back]
- Outside with embossing for name plate
- Right hinged doors
- With cylinder lock per door
- Lower structure on feet
- Ground clearance: 150 mm

**OPTIONS**

Options see page 203

	30 COMPARTMENTS	40 COMPARTMENTS	
<b>COMP.</b>	W 180 x D 180 x H 100	W 180 x D 180 x H 70	*Clear dimension
<b>WIDTH</b>	460	460	
<b>HEIGHT</b>	1850/2050	1850/2050	
<b>ART. NO. VA</b>	18.07.02.03	18.07.02.01	

ST = Steel  
VA = Stainless steel

**TYPE FS3**

**Compartment cabinets with 3 compartments on top of each other**

**COMPARTMENT CABINET FS3 CLOSED**



Version: with feet, stainless steel [VA]

**Wall-mounted D: 500 mm**



**With feet D: 500 mm**



	1 BLOCK	
WIDTH	320	420
HEIGHT	1700/1900	1700/1900
COMP.	1x 300	1x 400
ART. NO. ST	45.00.05.00	45.00.05.01
ART. NO. VA	45.10.05.00	45.10.05.01

	1 BLOCK	
WIDTH	320	420
HEIGHT	1850/2050	1850/2050
COMP.	1x 300	1x 400
ART. NO. ST	45.00.05.10	45.00.05.11
ART. NO. VA	45.10.05.10	45.10.05.11

**COMPARTMENT CABINET FS3 OPEN**



Version: with feet, stainless steel [VA]

**Wall-mounted D: 500 mm**

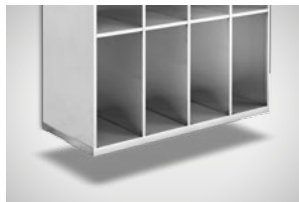

**With feet D: 500 mm**



	1 BLOCK	
WIDTH	320	420
HEIGHT	1700/1900	1700/1900
COMP.	1x 300	1x 400
ART. NO. ST	45.00.06.00	45.00.06.01
ART. NO. VA	45.10.06.00	45.10.06.01

	1 BLOCK	
WIDTH	320	420
HEIGHT	1850/2050	1850/2050
COMP.	1x 300	1x 400
ART. NO. ST	45.00.06.10	45.00.06.11
ART. NO. VA	45.10.06.10	45.10.06.11

**FS3 CLOSED**

- Single-walled doors, smooth, without label frame
- Right hinged doors, mounted on pivot pins
- With cylinder lock incl. 2 keys
- Integrated pitched roof [200 mm higher at the back]

- Lower structure as wall-mounted or on feet [150 mm ground clearance]
- With 3 overlying shelves
- Compartment clearance: W: 230/330 x D: 465 x H: 510 mm suitable for motorcycle helmets!

2 BLOCKS	
610	810
1700/1900	1700/1900
2x 300	2x 400
45.00.05.02	45.00.05.03
45.10.05.02	45.10.05.03

3 BLOCKS	
900	1200
1700/1900	1700/1900
3x 300	3x 400
45.00.05.04	45.00.05.05
45.10.05.04	45.10.05.05

4 BLOCKS
1190
1700/1900
4x 300
45.00.05.06
45.10.05.06

2 BLOCKS	
610	810
1850/2050	1850/2050
2x 300	2x 400
45.00.05.12	45.00.05.13
45.10.05.12	45.10.05.13

3 BLOCKS	
900	1200
1850/2050	1850/2050
3x 300	3x 400
45.00.05.14	45.00.05.15
45.10.05.14	45.10.05.15

4 BLOCKS
1190
1850/2050
4x 300
45.00.05.16
45.10.05.16

2 BLOCKS	
610	810
1700/1900	1700/1900
2x 300	2x 400
45.00.06.02	45.00.06.03
45.10.06.02	45.10.06.03

3 BLOCKS	
900	1200
1700/1900	1700/1900
3x 300	3x 400
45.00.06.04	45.00.06.05
45.10.06.04	45.10.06.05

4 BLOCKS
1190
1700/1900
4x 300
45.00.06.06
45.10.06.06

2 BLOCKS	
610	810
1850/2050	1850/2050
2x 300	2x 400
45.00.06.12	45.00.06.13
45.10.06.12	45.10.06.13

3 BLOCKS	
900	1200
1850/2050	1850/2050
3x 300	3x 400
45.00.06.14	45.00.06.15
45.10.06.14	45.10.06.15

4 BLOCKS
1190
1850/2050
4x 300
45.00.06.16
45.10.06.16

ST = Steel  
VA = Stainless steel

**FS3 OPEN**

- As FS3 closed, but: without doors

**OPTIONS**

Options see page 203

**BODY AND DOOR COLOURS**

You can find all colour variants on Page 202

**TYPE FS4**

**Compartment cabinets with 4 compartments on top of each other**

**COMPARTMENT CABINET FS4 CLOSED**



Version: with feet, stainless steel [VA]

**Wall-mounted D: 500 mm**



**With feet D: 500 mm**



	1 BLOCK	
WIDTH	320	420
HEIGHT	1700/1900	1700/1900
COMP.	1x 300	1x 400
ART. NO. ST	45.00.05.20	45.00.05.21
ART. NO. VA	45.10.05.20	45.10.05.21

	1 BLOCK	
WIDTH	320	420
HEIGHT	1850/2050	1850/2050
COMP.	1x 300	1x 400
ART. NO. ST	45.00.05.30	45.00.05.31
ART. NO. VA	45.10.05.30	45.10.05.31

**COMPARTMENT CABINET FS4 OPEN**



Version: with feet, stainless steel [VA]

**Wall-mounted D: 500 mm**



**With feet D: 500 mm**



	1 BLOCK	
WIDTH	320	420
HEIGHT	1700/1900	1700/1900
COMP.	1x 300	1x 400
ART. NO. ST	45.00.06.20	45.00.06.21
ART. NO. VA	45.10.06.20	45.10.06.21

	1 BLOCK	
WIDTH	320	420
HEIGHT	1850/2050	1850/2050
COMP.	1x 300	1x 400
ART. NO. ST	45.00.06.30	45.00.06.31
ART. NO. VA	45.10.06.30	45.10.06.31

**FS4 CLOSED**

- Single-walled doors, smooth, without label frame
- Right hinged doors, mounted on pivot pins
- With cylinder lock incl. 2 keys
- Integrated pitched roof [200 mm higher at the back]

- Lower structure as wall-mounted or on feet [150 mm ground clearance]
- With 4 stacked compartments
- Compartment clearance: W: 230/330 x D: 465 x H: 375 mm

2 BLOCKS	
610	810
1700/1900	1700/1900
2x 300	2x 400
45.00.05.22	45.00.05.23
45.10.05.22	45.10.05.23

3 BLOCKS	
900	1200
1700/1900	1700/1900
3x 300	3x 400
45.00.05.24	45.00.05.25
45.10.05.24	45.10.05.25

4 BLOCKS
1190
1700/1900
4x 300
45.00.05.26
45.10.05.26

2 BLOCKS	
610	810
1850/2050	1850/2050
2x 300	2x 400
45.00.05.32	45.00.05.33
45.10.05.32	45.10.05.33

3 BLOCKS	
900	1200
1850/2050	1850/2050
3x 300	3x 400
45.00.05.34	45.00.05.35
45.10.05.34	45.10.05.35

4 BLOCKS
1190
1850/2050
4x 300
45.00.05.36
45.10.05.36

2 BLOCKS	
610	810
1700/1900	1700/1900
2x 300	2x 400
45.00.06.22	45.00.06.23
45.10.06.22	45.10.06.23

3 BLOCKS	
900	1200
1700/1900	1700/1900
3x 300	3x 400
45.00.06.24	45.00.06.25
45.10.06.24	45.10.06.25

4 BLOCKS
1190
1700/1900
4x 300
45.00.06.26
45.10.06.26

2 BLOCKS	
610	810
1850/2050	1850/2050
2x 300	2x 400
45.00.06.32	45.00.06.33
45.10.06.32	45.10.06.33

3 BLOCKS	
900	1200
1850/2050	1850/2050
3x 300	3x 400
45.00.06.34	45.00.06.35
45.10.06.34	45.10.06.35

4 BLOCKS
1190
1850/2050
4x 300
45.00.06.36
45.10.06.36

ST = Steel  
VA = Stainless steel

**FS4 OPEN**

- As FS4 closed, but: without doors

**OPTIONS**

Options see page 203

**BODY AND DOOR COLOURS**

You can find all colour variants on Page 202

**TYPE FS5**

**Compartment cabinets with 5 compartments on top of each other**

**COMPARTMENT CABINET FS5 CLOSED**



Version with feet and Makrolon doors, steel [ST]

**Wall-mounted D: 500 mm**



**With feet D: 500 mm**



	1 BLOCK	
WIDTH	320	420
HEIGHT	1700/1900	1700/1900
COMP.	1x 300	1x 400
ART. NO. ST	45.00.05.40	45.00.05.41
ART. NO. VA	45.10.05.40	45.10.05.41

	1 BLOCK	
WIDTH	320	420
HEIGHT	1850/2050	1850/2050
COMP.	1x 300	1x 400
ART. NO. ST	45.00.05.50	45.00.05.51
ART. NO. VA	45.10.05.50	45.10.05.51

**COMPARTMENT CABINET FS5 OPEN**



Version: with feet, stainless steel [VA]

**Wall-mounted D: 500 mm**



**With feet D: 500 mm**



	1 BLOCK	
WIDTH	320	420
HEIGHT	1700/1900	1700/1900
COMP.	1x 300	1x 400
ART. NO. ST	45.00.06.40	45.00.06.41
ART. NO. VA	45.10.06.40	45.10.06.41

	1 BLOCK	
WIDTH	320	420
HEIGHT	1850/2050	1850/2050
COMP.	1x 300	1x 400
ART. NO. ST	45.00.06.50	45.00.06.51
ART. NO. VA	45.10.06.50	45.10.06.51

**FS5 CLOSED**

- Single-walled doors, smooth, without label frame
- Right hinged doors, mounted on pivot pins
- With cylinder lock incl. 2 keys
- Integrated pitched roof [200 mm higher at the back]

- Lower structure as wall-mounted or on feet [150 mm ground clearance]
- With 5 stacked compartments
- Compartment clearance: W: 230/330 x D: 465 x H: 295 mm



2 BLOCKS	
610	810
1700/1900	1700/1900
2x 300	2x 400
45.00.05.42	45.00.05.43
45.10.05.42	45.10.05.43

3 BLOCKS	
900	1200
1700/1900	1700/1900
3x 300	3x 400
45.00.05.44	45.00.05.45
45.10.05.44	45.10.05.45

4 BLOCKS
1190
1700/1900
4x 300
45.00.05.46
45.10.05.46

2 BLOCKS	
610	810
1850/2050	1850/2050
2x 300	2x 400
45.00.05.52	45.00.05.53
45.10.05.52	45.10.05.53

3 BLOCKS	
900	1200
1850/2050	1850/2050
3x 300	3x 400
45.00.05.54	45.00.05.55
45.10.05.54	45.10.05.55

4 BLOCKS
1190
1850/2050
4x 300
45.00.05.56
45.10.05.56

2 BLOCKS	
610	810
1700/1900	1700/1900
2x 300	2x 400
45.00.06.42	45.00.06.43
45.10.06.42	45.10.06.43

3 BLOCKS	
900	1200
1700/1900	1700/1900
3x 300	3x 400
45.00.06.44	45.00.06.45
45.10.06.44	45.10.06.45

4 BLOCKS
1190
1700/1900
4x 300
45.00.06.46
45.10.06.46

2 BLOCKS	
610	810
1850/2050	1850/2050
2x 300	2x 400
45.00.06.52	45.00.06.53
45.10.06.52	45.10.06.53

3 BLOCKS	
900	1200
1850/2050	1850/2050
3x 300	3x 400
45.00.06.54	45.00.06.55
45.10.06.54	45.10.06.55

4 BLOCKS
1190
1850/2050
4x 300
45.00.06.56
45.10.06.56

ST = Steel  
VA = Stainless steel

**FS5 OPEN**

- As FS5 closed, but: without doors

**OPTIONS**

Options see page 203

**BODY AND DOOR COLOURS**

You can find all colour variants on Page 202

**TYPE FS6-AF-SZ-EU-G**

**Compartment cabinets with 6 compartments on top of each other**

**COMPARTMENT CABINET FS6 CLOSED**



Version: with feet, steel [ST]

**Wall-mounted D: 500 mm**



**With feet D: 500 mm**



	1 BLOCK	
WIDTH	320	420
HEIGHT	1700/1900	1700/1900
COMP.	1x 300	1x 400
ART. NO. ST	45.00.05.60	45.00.05.61
ART. NO. VA	45.10.05.60	45.10.05.61

	1 BLOCK	
WIDTH	320	420
HEIGHT	1850/2050	1850/2050
COMP.	1x 300	1x 400
ART. NO. ST	45.00.05.70	45.00.05.71
ART. NO. VA	45.10.05.70	45.10.05.71

**COMPARTMENT CABINET FS6 OPEN**



Version: with feet, stainless steel [VA]

**Wall-mounted D: 500 mm**



**With feet D: 500 mm**



	1 BLOCK	
WIDTH	320	420
HEIGHT	1700/1900	1700/1900
COMP.	1x 300	1x 400
ART. NO. ST	45.00.06.60	45.00.06.61
ART. NO. VA	45.10.06.60	45.10.06.61

	1 BLOCK	
WIDTH	320	420
HEIGHT	1850/2050	1850/2050
COMP.	1x 300	1x 400
ART. NO. ST	45.00.06.70	45.00.06.71
ART. NO. VA	45.10.06.70	45.10.06.71

**FS6 CLOSED**

- Compartment cabinet with doors in accordance with EU directive
- Wall-mounted version
- 2 compartment widths [300 or 400 mm] available
- 6 stacked compartments
- Single-walled doors, smooth, without label frame

- Doors hinged on the right, mounted on pivot bolts
- Doors lockable with cylinder lock, incl. 2 keys
- Compartment clearance: W: 230/330 x D: 465 x H: 240 mm
- Body and door colours available according to colour overview
- Integrated pitched roof [200 mm higher at the back]
- Smooth shelf with ventilation holes

2 BLOCKS	
610	810
1700/1900	1700/1900
2x 300	2x 400
45.00.05.62	45.00.05.63
45.10.05.62	45.10.05.63

3 BLOCKS	
900	1200
1700/1900	1700/1900
3x 300	3x 400
45.00.05.64	45.00.05.65
45.10.05.64	45.10.05.65

4 BLOCKS
1190
1700/1900
4x 300
45.00.05.66
45.10.05.66

2 BLOCKS	
610	810
1850/2050	1850/2050
2x 300	2x 400
45.00.05.72	45.00.05.73
45.10.05.72	45.10.05.73

3 BLOCKS	
900	1200
1850/2050	1850/2050
3x 300	3x 400
45.00.05.74	45.00.05.75
45.10.05.74	45.10.05.75

4 BLOCKS
1190
1850/2050
4x 300
45.00.05.76
45.10.05.76

2 BLOCKS	
610	810
1700/1900	1700/1900
2x 300	2x 400
45.00.06.62	45.00.06.63
45.10.06.62	45.10.06.63

3 BLOCKS	
900	1200
1700/1900	1700/1900
3x 300	3x 400
45.00.06.64	45.00.06.65
45.10.06.64	45.10.06.65

4 BLOCKS	
1190	1590
1700/1900	1850/2050
4x 300	4x 400
45.00.06.66	---
45.10.06.66	45.10.06.67

2 BLOCKS	
610	810
1850/2050	1850/2050
2x 300	2x 400
45.00.06.72	45.00.06.73
45.10.06.72	45.10.06.73

3 BLOCKS	
900	1200
1850/2050	1850/2050
3x 300	3x 400
45.00.06.74	45.00.06.75
45.10.06.74	45.10.06.75

4 BLOCKS	
1190	1590
1700/1900	1850/2050
4x 300	4x 400
45.00.06.76	---
45.10.06.76	45.10.06.77

**FS6 OPEN**

- As FS6 closed, but: without doors

**OPTIONS**

Options [see page 203](#)

**BODY AND DOOR COLOURS**

You can find all colour variants on Page 202

ST = Steel  
VA = Stainless steel

**TYPE WAS**

# Laundry dispensing cabinets

STEEL / STAINLESS STEEL 1.4301



Version: with feet, stainless steel [VA], Article no. 45.10.07.57



Version: with feet, stainless steel [VA], Article no. 45.10.07.57

**Wall-mounted D: 500 mm**



	1 BLOCK		2 BLOCKS	
<b>WIDTH</b>	420	420	810	810
<b>HEIGHT</b>	1700/1930	1700/1930	1700/1930	1700/1930
<b>COMP.</b>	5	10	10 [2 x 5]	20 [2 x 10]
<b>ART. NO. ST</b>	45.00.07.50	45.00.07.52	45.00.07.51	45.00.07.53
<b>ART. NO. VA</b>	45.10.07.50	45.10.07.52	45.10.07.51	45.10.07.53

**With feet D: 500 mm**



	1 BLOCK		2 BLOCKS	
<b>WIDTH</b>	420	420	810	810
<b>HEIGHT</b>	1850/2080	1850/2080	1850/2080	1850/2080
<b>COMP.</b>	5	10	10 [2x5]	20 [2x10]
<b>ART. NO. ST</b>	45.00.07.54	45.00.07.56	45.00.07.55	45.00.07.57
<b>ART. NO. VA</b>	45.10.07.54	45.10.07.56	45.10.07.55	45.10.07.57

- 1 or 2 compartments with 5 or 10 overlying shelves
- With one central door  
[for simple feeding of all compartments at once]
- Compartments and centre door with cylinder lock
- With pitched roof, 230 mm higher at the rear
  - > ST [Steel]: attachment
  - > VA [stainless steel]: integrated
- Lower structure as wall-mounted or on feet  
[150 mm ground clearance]

**BODY AND DOOR COLOURS**

You can find all colour variants on Page 202

ST = Steel  
VA = Stainless steel

**COMPARTMENT CLEARANCE**

With 5 doors: W: 251 x D: 475 x H: 269 mm  
With 10 doors: W: 251 x D: 475 x H: 126 mm

**TYPE WSS**

# Laundry collector cabinets

STEEL / STAINLESS STEEL 1.4301



Version: with feet, stainless steel [VA]



Version: with feet, stainless steel [VA]

**Wall-mounted D: 500 mm**

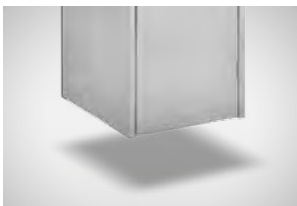

1 BLOCK	
<b>WIDTH</b>	<b>420</b>
<b>HEIGHT</b>	1700/1930
<b>ART. NO. ST</b>	45.00.07.90 <sup>1</sup>
<b>ART. NO. VA</b>	45.00.07.92 <sup>2</sup>

<sup>1</sup> Height 1,700 mm  
<sup>2</sup> Height: 1,700/1,930 mm

**With feet D: 500 mm**



1 BLOCK	
<b>WIDTH</b>	<b>420</b>
<b>HEIGHT</b>	1850/2080
<b>ART. NO. ST</b>	45.00.07.91 <sup>1</sup>
<b>ART. NO. VA</b>	45.00.07.93 <sup>2</sup>

ST = Steel  
 VA = Stainless steel

- Swing flap integrated into the top of the hinged door
- Interior with laundry bag hooks
- Hinged door lockable with cylinder lock
- [incl. 2 keys]
- With pitched roof, 230 mm higher at the rear
- in steel design: WITHOUT pitched roof  
 [Option: Pitched roof attachment: Article no. 00.85.04.12]
- Lower structure as wall-mounted or on feet  
 [150 mm ground clearance]

**OPTIONS**

Options see page 203

# Colours

## COLOUR GROUP I

without surcharge

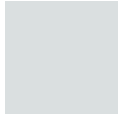

**Light grey**  
RAL 7035



**Black grey**  
RAL 7021



**Anthracite grey**  
RAL 7016



**Volcanic grey**  
RDS 000 50 00



**Grey metallic**  
DB 703 smooth



**Light blue**  
RAL 5012



**Distant blue**  
RAL 5023

## COLOUR GROUP II

no surcharge for fronts, if carcass: light grey RAL 7035 [see colour group I]\*



**Gentian blue**  
RAL 5010



**Lapis blue**  
RDS 270 20 29



**Flame red**  
RAL 3000



**Ruby red**  
RAL 3003

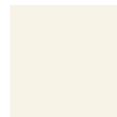

**Pearl white**  
RAL 1013



**Light green**  
RAL 6027



**Water blue**  
RAL 5021



**Moss green**  
RAL 6005

## COLOUR GROUP III

no surcharge for fronts, if carcass: light grey RAL 7035 [see colour group I]\*



**Pastel yellow**  
RDS 095 90 30



**Sulphur yellow**  
RDS 095 90 59



**Sunny yellow**  
RDS 080 80 60



**Yellow-orange**  
RAL 2000



**Pastel green**  
RDS 110 90 20



**Viridian green**  
RDS 110 80 60



**Traffic white**  
RAL 9016



**White aluminium**  
RAL 9006



**Grey aluminium**  
RAL 9007

\* Steel body:  
light grey RAL 7035 = door colour without surcharge  
Other colour combinations at an additional charge:  
on request!



## Options

### LOCKING TECHNOLOGY OPTIONS (STEEL + STAINLESS STEEL)

Padlock [brass] only for steel cabinets	Article no. 00.00.02.10
Padlock [100 % stainless brass] for all cabinets	Article no. 99.80.03.52
Mechanical combination lock	Article no. 04.80.07.04
Cylinder lock, simple	Article no. 00.00.08.70
Cylinder lock locking system	Article no. 00.01.00.10
Main key locking system	Article no. 00.00.12.00

### ADDITIONAL OPTIONS

Plastic shoe shell	Article no. 04.50.07.07
Licence plate sticker	Article no. 04.80.07.01
Number plate made of plastic	Article no. 85.02.06.11
Number plate made of stainless steel	Article no. 85.01.06.11

### OPTIONS: FOR STEEL ONLY

Damp interiors version (body electrolytically galvanised)	Article no. 00.80.00.20
Height adjustment feet: +/- 10 mm	Article no. 00.80.00.26
Additional shelf (compartment width 300 mm)	Article no. 00.80.00.80
Additional shelf (compartment width 400 mm)	Article no. 00.80.02.80

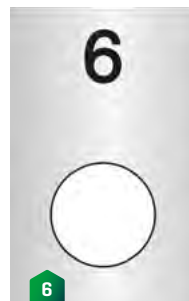

- 1 Height adjustment screws
- 2 Mechanical combination lock
- 3 Additional shelf
- 4 Number plate made of stainless steel
- 5 Plastic shoe shell
- 6 Number plate made of plastic

**TYPE SB-FK**

**Bench**

FOOD-SAFE PLASTIC



Type SB-FK 2000

- Of food-safe plastic
- With 5 rails for comfortable seating
- Available only without shoe rack

TYPE	SHOE RACK	DIMENSIONS W x D x H in mm	ARTICLE NO.
SB-FK 1000	without	1000 x 400 x 420	45.00.00.36
SB-FK 2000	without	2000 x 400 x 420	45.00.00.37

Other lengths and designs on request!

**TYPE SB-F**

**Bench**

STEEL, POWDER-COATED



Type SB-F/MR 1500

- Made of powder-coated steel
- Stable square tube construction
- 30 x 30 mm (frame colour: RAL 7021, anthracite)
- Seat slats made of plastic with steel insert  
[Colour: RAL 7035, light grey]
- Available with or without shoe rack
- Adjustable floor gliders, 10 mm level compensation

TYPE	SHOE RACK	DIMENSIONS W x D x H in mm	ARTICLE NO.
SB-F/OR 1000	without	1000 x 355 x 420	45.00.00.30
SB-F/OR 1500	without	1500 x 355 x 420	45.00.00.31
SB-F/OR 2000	without	2000 x 355 x 420	45.00.00.32
SB-F/MR 1000	with	1000 x 355 x 420	45.00.00.33
SB-F/MR 1500	with	1500 x 355 x 420	45.00.00.34
SB-F/MR 2000	with	2000 x 355 x 420	45.00.00.35

Other lengths and designs on request!

**TYPE SB-FE**

# Bench

STAINLESS STEEL 1.4301



Type SB-FE/R 1500

- Stable frame construction
- Available with or without shoe rack
- With 4 height-adjustable feet
- With white plastic seat slats made of PE 500, thickness 20 mm

TYPE	SHOE RACK	DIMENSIONS	ARTICLE NO.
		W x D x H in mm	
SB-FE/O 1000	without	1000 x 355 x 420	45.00.02.21
SB-FE/O 1500	without	1500 x 355 x 420	45.00.02.23
SB-FE/O 2000	without	2000 x 355 x 420	45.00.02.25
SB-FE/R 1000	with	1000 x 355 x 420	45.00.02.20
SB-FE/R 1500	with	1500 x 355 x 420	45.00.02.22
SB-FE/R 2000	with	2000 x 355 x 420	45.00.02.24

Other lengths and designs on request!

**TYPE USB**

# Changeover bench

STAINLESS STEEL 1.4301



Type USB-D 3/6 HL

- 2 or 3 levels for shoes
- One-side of double-side placement
- Compartment dimensions for shoes: approx. W 305 x H 150 mm
- Front skirting board made of stainless steel

TYPE	PLACEMENT	CAPACITY	DIMENSIONS	ARTICLE NO.
		Compartments	W x D x H in mm	
<b>2 LEVELS</b>				
USB-2-4/10	one-sided	6	1000 x 400 x 420	45.00.02.30
USB-2-4/15	one-sided	10	1500 x 400 x 420	45.00.02.31
USB-2-4/20	one-sided	12	2000 x 400 x 420	45.00.02.32
USB-2-8/10	double-sided	12	1000 x 800 x 420	45.00.02.36
USB-2-8/15	double-sided	20	1500 x 800 x 420	45.00.02.37
USB-2-8/20	double-sided	24	2000 x 800 x 420	45.00.02.38
<b>3 LEVELS</b>				
USB-3-4/10	one-sided	9	1000 x 400 x 650	45.00.02.33
USB-3-4/15	one-sided	15	1500 x 400 x 650	45.00.02.34
USB-3-4/20	one-sided	18	2000 x 400 x 650	45.00.02.35
USB-3-8/10	double-sided	18	1000 x 800 x 650	45.00.02.39
USB-3-8/15	double-sided	30	1500 x 800 x 650	45.00.02.40
USB-3-8/20	double-sided	36	2000 x 800 x 650	45.00.02.41

Other lengths and designs on request!

**TYPE USB ECOLINE**

## Changeover bench

STAINLESS STEEL 1.4301



Type USB-D 3/10

- Stable stainless steel tubular frame construction
- Inclined stainless steel seat
- Permanently welded shoe grids
- Height-adjustable feet for levelling

TYPE	PLACEMENT	CAPACITY Shoes	DIMENSIONS W x D x H in mm	ARTICLE NO.
<b>2 LEVELS</b>				
USB-E 2/3	one-sided	6 pair	1000 x 400 x 420	46.00.02.30
USB-E 2/5	one-sided	10 pairs	1500 x 400 x 420	46.00.02.31
USB-E 2/6	one-sided	12 pairs	2000 x 400 x 420	46.00.02.32
USB-D 2/3	double-sided	12 pairs	1000 x 600 x 420	46.00.02.55
USB-D 2/5	double-sided	20 pairs	1500 x 600 x 420	46.00.02.54
USB-D 2/6	double-sided	24 pairs	2000 x 600 x 450	46.00.02.53
<b>3 LEVELS</b>				
USB-E 3/3	one-sided	9 pair	1000 x 400 x 650	46.00.02.33
USB-E 3/5	one-sided	15 pairs	1500 x 400 x 650	46.00.02.34
USB-E 3/6	one-sided	18 pairs	2000 x 400 x 650	46.00.02.35
USB-D 3/3	double-sided	18 pairs	1000 x 600 x 650	46.00.02.52
USB-D 3/5	double-sided	30 pairs	1500 x 600 x 650	46.00.02.51
USB-D 3/6	double-sided	36 pairs	2000 x 600 x 650	46.00.02.50

Other lengths and designs on request!

**TYPE A-USB**

## Top cabinet for swivelling bench

STAINLESS STEEL 1.4301



Type A-USB 600

- Laterally sloping pitched roof, height: 200 mm
- Open at the front
- 4 height-adjustable storage shelves
- Four threaded holes (M6) in the base area for bolting to the swivelling bench

TYPE	SUITABLE FOR	DIMENSIONS W x D x H in mm	ARTICLE NO.
A-USB 400	Bench depth 400 mm	360 x 400 x 1550	45.00.03.51
A-USB 600	Bench depth 600 mm	360 x 600 x 1550	45.00.03.50



03

## Practical example

---







**TYPE SC-W HIGHLINE**

## Shoe & clog holders

STAINLESS STEEL 1.4301



Type SC-W 3 H

For wall-mounted, hygienic storage of shoes or clogs

- For wall mounting provided by the customer or at optional Wall or floor stands
- Hygienic design version with square profile
- Robust version made of full material, Ø 8 mm
- 4 mounting holes, Ø 9 mm
- Capacity: 1 - 6 pairs of shoes or clogs

TYPE	CAPACITY	DIMENSIONS W x D x H in mm	ARTICLE NO.
SC-W 1 H	1 pair	250 x 185 x 224	18.00.03.49
SC-W 2 H	2 pair	500 x 185 x 224	18.00.03.50
SC-W 3 H	3 pair	750 x 185 x 224	18.00.03.51
SC-W 4 H	4 pair	1000 x 185 x 224	18.00.03.52
SC-W 5 H	5 pair	1250 x 185 x 224	18.00.03.53
SC-W 6 H	6 pair	1500 x 185 x 224	18.00.03.54

**TYPE STH-W HIGHLINE**

## Boot holders

STAINLESS STEEL 1.4301



Type STH-W 4 H

For wall-mounted, hygienic storage of boots

- For wall mounting provided by the customer or at optional Wall or floor stands
- Hygienic design version with square profile
- Robust version made of full material, Ø 8 mm
- 4 mounting holes, Ø 9 mm
- Capacity: 1 - 6 pairs of shoes or clogs

TYPE	CAPACITY	DIMENSIONS W x D x H in mm	ARTICLE NO.
STH-W 1 H	1 pair	250 x 432 x 439	18.00.03.43
STH-W 2 H	2 pair	500 x 432 x 439	18.00.03.44
STH-W 3 H	3 pair	750 x 432 x 439	18.00.03.45
STH-W 4 H	4 pair	1000 x 432 x 439	18.00.03.46
STH-W 5 H	5 pair	1250 x 432 x 439	18.00.03.47
STH-W 6 H	6 pair	1500 x 432 x 439	18.00.03.48

**TYPE HSA**

## Glove holders

STAINLESS STEEL 1.4301



Type HSA-4

For wall-mounted, hygienic storage of gloves

- For wall mounting provided by the customer or at optional wall or standing frames

- 4 mounting holes, Ø 9 mm
- Stable version made of full material, Ø 8 mm
- Capacity: 4 - 6 pairs of gloves

TYPE	CAPACITY	DIMENSIONS W x D x H in mm	ARTICLE NO.
HSA-4	4 pair	750 x 446 x 288	10.00.04.00
HSA-5	5 pair	950 x 446 x 288	10.00.04.01
HSA-6	6 pair	1150 x 446 x 288	10.00.04.02

**TYPE WSS**

## Wall fitting

STAINLESS STEEL 1.4301



Type WSS-5

Type WSS-3 with retaining strips

For hygienic wall mounting of shoes, clogs, boots or gloves holder bars!

- Just screw them on the holder bars and hang up.

- Hygienic design with pitched roof
- Version: 2 - 6-row
- Square profile tubes 40 x 40 x 2 mm

TYPE	VERSION	DIMENSIONS W x D x H in mm	ARTICLE NO.
WSS-2	2-row	40 x 140 x 770	18.00.01.93
WSS-3	3-row	40 x 140 x 1090	18.00.01.92
WSS-4	4-row	40 x 140 x 1410	18.00.01.91
WSS-5	5-row	40 x 140 x 1730	18.00.01.90
WSS-6	6-row	40 x 140 x 2050	18.00.01.94

**TYPE STG**

## Stand frame

STAINLESS STEEL 1.4301



Type STG-D

Type STG with 6 retaining strips

For hygienic suspension of shoes, clogs, boots or gloves holder bars!

- Just screw them on the holder bars and hang up
- Hygienic design with pitched roof
- Square profile tubes 40 x 40 x 2 mm

- Version: 6 rows, one-sided or 2x 6-row on both sides [also available in mobile version]
- height-adjustable supporting feet with a flap
- for mounting on the floor

TYPE	VERSION	ARTICLE NO.
STG	Stand, one side	18.00.01.96
STG-D	Stand, both sides	18.00.01.97
STG-DF	mobile, both sides	18.00.01.98

**TYPE HL-E**

## Single hook rail

STAINLESS STEEL 1.4301



Type HL-E 6

- Organised storage of work clothing
- Robust construction made of solid material
- Wall mounting
- Single hooks with 6, 8 or 10 hooks

TYPE*	VERSION	DIMENSIONS W x D x H in mm	ARTICLE NO.
HL-E 6	6 hooks	750 x 117 x 165	18.00.03.10
HL-E 8	8 Hooks	950 x 117 x 165	18.00.03.11
HL-E 10	10 hooks	1150 x 117 x 165	18.00.03.12

**TYPE HL-EG**

## Hearing protection hook strip

STAINLESS STEEL 1.4301

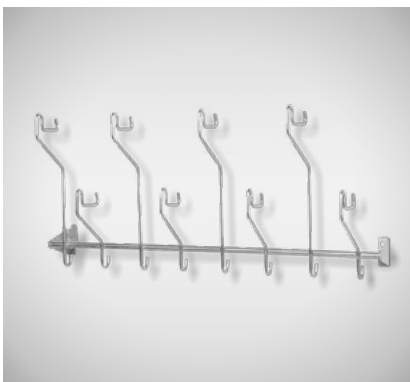

Type HL-EG 8

- Organised storage of work clothing and hearing protection
- Robust construction made of solid material
- Version for wall mounting
- 6, 8 or 10 individual hooks for work clothing and hearing protection

TYPE*	VERSION H/G*	DIMENSIONS W x D x H in mm	ARTICLE NO.
HL-EG 6	6	750 x 117 x 165	18.00.03.13
HL-EG 8	8	950 x 117 x 165	18.00.03.14
HL-EG 10	10	1150 x 117 x 165	18.00.03.15

\*Legend: H= Single hook for work clothes; G= Hearing protection

**TYPE HL-D**

## Double hook rail

STAINLESS STEEL 1.4301



Type HL-D 4

- Organised storage of work clothing
- Robust construction made of solid material
- 2 different versions for wall mounting
- Capacity: 6, 8 or 10 double hooks
- Extended double hooks for helmets (Type HL-DH)

TYPE*	DOUBLE HOOK	HOOK EXTENDED	DIMENSIONS W x D x H in mm	ARTICLE NO.
HL-D 4	4	No	750 x 135 x 165	18.00.03.16
HL-D 5	5	No	950 x 135 x 165	18.00.03.17
HL-D 6	6	No	1150 x 135 x 165	18.00.03.18
HL-DH 4	4	Yes	750 x 135 x 297	18.00.03.19
HL-DH 5	5	Yes	950 x 134 x 297	18.00.03.20
HL-DH 6	6	Yes	1150 x 134 x 297	18.00.03.21

**TYPE HL-ECO**

## Hook rail

STAINLESS STEEL 1.4301



Type HL-5 Eco

- Eco hook rail for storing Workwear
- Robust construction made of solid material
- For wall mounting on site
- Optionally with 5 or 10 hooks
- Hook protruding 30 mm outwards
- Hook spacing 100 mm
- Hook width 15 mm

TYPE*	VERSION	DIMENSIONS W x D x H in mm	ARTICLE NO.
HL-5 Eco	5 hooks	500 x 35 x 40	18.00.03.90
HL-10 Eco	10 hooks	1000 x 35 x 40	18.00.03.91

**TYPE KHL**

## Coat hook strip

STAINLESS STEEL 1.4301



Type KHL-W2x20

- Robust industrial design made of stainless steel
- Version made of open profile and flat material in Hygienic-Design
- Wall-mounted version or available as a floor model
- Various capacities [hooks] available
- 1-row to 3-row hook rail versions available
- Single-sided or double-sided [floor model only] design
- Lasered numbering included

TYPE	VERSION	CAPACITY Coat	ROWS Quantity	DIMENSIONS W x D x H in mm	ARTICLE NO.
KHL-W1x10	wall-mounted	10	1	955 x 350 x 380	18.00.04.20
KHL-W2x10	wall-mounted	20	2	955 x 350 x 380	18.00.04.21
KHL-W3x10	wall-mounted	30	3	955 x 350 x 380	18.00.04.22
KHL-W1x15	wall-mounted	15	1	1455 x 350 x 380	18.00.04.23
KHL-W2x15	wall-mounted	30	2	1455 x 350 x 380	18.00.04.24
KHL-W3x15	wall-mounted	45	3	1455 x 350 x 380	18.00.04.25
KHL-W1x20	wall-mounted	20	1	1955 x 350 x 380	18.00.04.26
KHL-W2x20	wall-mounted	40	2	1955 x 350 x 380	18.00.04.27
KHL-W3x20	wall-mounted	60	3	1955 x 350 x 380	18.00.04.28
KHL-S1x10	Floor model	10	1	955 x 350 x 1800	18.00.04.29
KHL-S2x10	Floor model	20	2	955 x 350 x 1800	18.00.04.30
KHL-S3x10	Floor model	30	3	955 x 350 x 1800	18.00.04.31
KHL-S1x15	Floor model	15	1	1455 x 350 x 1800	18.00.04.32
KHL-S2x15	Floor model	30	2	1455 x 350 x 1800	18.00.04.33
KHL-S3x15	Floor model	45	3	1455 x 350 x 1800	18.00.04.34
KHL-S1x20	Floor model	20	1	1955 x 350 x 1800	18.00.04.35
KHL-S2x20	Floor model	40	2	1955 x 350 x 1800	18.00.04.36
KHL-S3x20	Floor model	60	3	1955 x 350 x 1800	18.00.04.37

**\* OPTIONS HL-E, HL-EG, HL-D, HL-ECO**

Numbering	on request
Mounting material	on request



**TYPE KA**

## Clothes rack

STAINLESS STEEL 1.4301

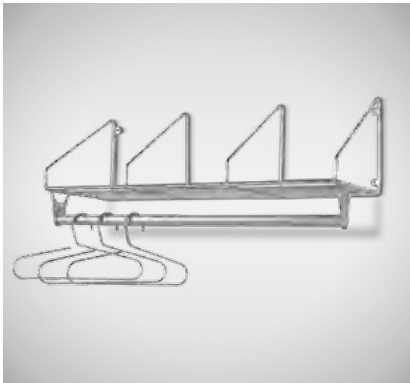

Type KA-MB

- organised + hygienic storage of work clothing
- Hygienic design made of solid stainless steel
- 2 different versions for wall mounting
- 3-section storage area
- Bow tube for hanging clothes hangers (only Type KA-MB)

TYPE	VERSION	DIMENSIONS W x D x H in mm	ARTICLE NO.
KA-0B	Without bow tube	1000 x 350 x 297	18.00.00.77
KA-MB	With bow tube	1000 x 350 x 404	18.00.00.78

**TYPE KG**

## Wardrobe

STAINLESS STEEL 1.4301



Type KG 3/1

- Organised storage of visitor coats etc.
- Hygienic design made of solid stainless steel
- For wall mounting
- 3-section storage area
- Compartment dimensions: 300 x 300 mm

TYPE	VERSION Compartments / Shelves	DIMENSIONS W x D x H in mm	ARTICLE NO.
KG 3/1	3 F / 1 E	1000 x 320 x 320	18.00.00.84
KG 3/2	6 F / 2 E	1000 x 320 x 610	18.00.00.83

**TYPE KB**

## Coat hanger

STAINLESS STEEL 1.4301

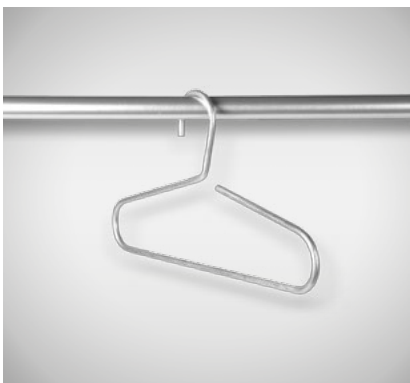

- For neatly hanging up work clothes
- Hygienic stainless steel design
- Stable design made from 8 mm solid material
- Suspension Ø max. 50 mm

TYPE	DIMENSIONS W x D x H in mm	ARTICLE NO.
KB	420 x 220	18.00.00.46



**TYPE KS-S/-W**

# Wardrobe

STAINLESS STEEL 1.4301



Type KS-W 90-50

- Our welded industrial design with sliding hooks
- Welded stainless steel design
- 2 different versions, with pedestals or wall-mounted
- Cabinet body closed on three sides
- Version in 1.0 mm material thickness
- Pitched roof, 200 mm higher at the back, in Hygienic-Design
- With 2 hinged door on the operator side
- Door with lockable T-handle including profile cylinder lock
- Interior with hat shelf, including clothes rail with 13 sliding hooks
- Wall-mounted version with wall mounting rail or with 4 height-adjustable plastic screw feet (+/- 30 mm)
- Standard ground clearance: 150 mm (with stand feet)

TYPE	VERSION	DOORS Hinged doors	DIMENSIONS W x D x H in mm	ARTICLE NO.
KS-W 50-50	Stand feet	2	500 x 500 x 1850/ 2050	18.00.04.55
KS-W 60-50	Stand feet	2	600 x 500 x 1850/ 2050	18.00.04.56
KS-W 70-50	Stand feet	2	700 x 500 x 1850/ 2050	18.00.04.57
KS-W 80-50	Stand feet	2	800 x 500 x 1850/ 2050	18.00.04.58
KS-W 90-50	Stand feet	2	900 x 500 x 1850/ 2050	18.00.04.59
KS-W 100-50	Stand feet	2	1000 x 500 x 1850/ 2050	18.00.04.60
KS-W 110-50	Stand feet	2	1100 x 500 x 1850/ 2050	18.00.04.61
KS-W 120-50	Stand feet	2	1200 x 500 x 1850/ 2050	18.00.04.62
KS-W 50-50	Wall-mounted	2	500 x 500 x 1850/ 2050	18.00.04.45
KS-W 60-50	Wall-mounted	2	600 x 500 x 1850/ 2050	18.00.04.46
KS-W 70-50	Wall-mounted	2	700 x 500 x 1850/ 2050	18.00.04.47
KS-W 80-50	Wall-mounted	2	800 x 500 x 1850/ 2050	18.00.04.48
KS-W 90-50	Wall-mounted	2	900 x 500 x 1850/ 2050	18.00.04.49
KS-W 100-50	Wall-mounted	2	1000 x 500 x 1850/ 2050	18.00.04.50
KS-W 110-50	Wall-mounted	2	1100 x 500 x 1850/ 2050	18.00.04.51
KS-W 120-50	Wall-mounted	2	1200 x 500 x 1850/ 2050	18.00.04.52



Detailed views of the interior

**TYPE SWG-HL**

## Apron wall coat rack

STAINLESS STEEL 1.4301



Type SWG-HL 1000

- Highline version - made entirely of hygienic round tube profile
- Hygienic-design version
- Capacity: max. 25 apron hangers [depending on type]\*
- Robust round tube profile construction Ø 30 x 1.5 mm
- Wall-mounted version
- Supplied without optional apron hangers

TYPE	VERSION	DIMENSIONS W x D x H in mm	ARTICLE NO.
SWG-HL 1000	wall-mounted	1000 x 670 x 680	18.00.02.90
SWG-HL 1500	wall-mounted	1500 x 670 x 680	18.00.02.91
SWG-HL 2000	wall-mounted	2000 x 670 x 680	18.00.02.92

**OPTIONS**

Apron bracket made of round tube, Type SB-M	Article no. 18.00.01.35
Apron hanger made of round steel, Type SB	Article no. 18.00.00.03

**TYPE SSG-HL**

## Apron coat rack

STAINLESS STEEL 1.4301



Type SSG-HL 1000

- Highline version - made entirely of hygienic round tube profile
- Hygienic-design version
- Capacity: max. 25 apron hangers [depending on type]
- Robust round tube profile construction Ø 42.4 x 1.5 mm
- Optional: Stand or mobile version
- Mobile version with 4 polyamide swivel casters, of which 2 swivel casters with locking mechanism, Ø 125 mm
- Bow tube thickness Ø 30 x 1.5 mm

TYPE	VERSION	DIMENSIONS W x D x H in mm	ARTICLE NO.
SSG-HL 1000	Floor model	1000 x 800 x 1845	18.00.02.93
SSG-HL 1500	Floor model	1500 x 800 x 1845	18.00.02.94
SSG-HL 2000	Floor model	2000 x 800 x 1845	18.00.02.95
SSG-HL 1000 F	Mobile	1000 x 800 x 1845	18.00.02.96
SSG-HL 1500 F	Mobile	1500 x 800 x 1845	18.00.02.97
SSG-HL 2000 F	Mobile	2000 x 800 x 1845	18.00.02.98

**OPTIONS**

Apron bracket made of round tube, Type SB-M	Article no. 18.00.01.35
Apron hanger made of round steel, Type SB	Article no. 18.00.00.03

**TYPE SB**

## Apron hanger

STAINLESS STEEL 1.4301

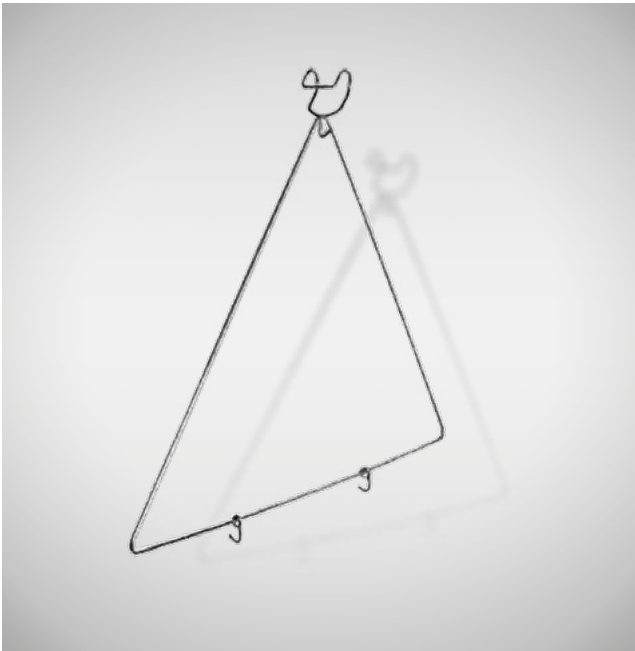

- For hygienic hanging of aprons
- Hygienic stainless steel design
- Sturdy design made from 6 mm solid material
- Suitable for all apron sizes and types
- Optimal drying due to automatic spreading
- Distance protection of the aprons by 75 mm wide suspension

TYPE	DIMENSIONS W x D x H in mm	ARTICLE NO.
SB	1125 x 75 x 776	18.00.00.03

**OPTIONS**

Numbering	on request
"Wear apron" pictogram sticker	Article no. 90.00.00.46

**TYPE SB-M**

## Apron hanger

STAINLESS STEEL 1.4301



- For hygienic hanging of aprons
- Stable round tube construction [tube ends: tightly welded!]
- Suitable for all apron types and sizes
- Optimal drying through automatic spreading
- Distance protection of the aprons by 75 mm wide suspension
- Suspension as a "roof" construction in Hygienic-Design

TYPE	DIMENSIONS W x D x H in mm	ARTICLE NO.
SB-M	1120 x 75 x 710	18.00.01.35

**OPTIONS**

Numbering	on request
"Wear apron" pictogram sticker	Article no. 90.00.00.46

**TYPE SWR**

# Shoe wall shelf

STAINLESS STEEL 1.4301



Type SWR-3/940

- Organised storage of shoes or clogs
- Hygienic design made of solid stainless steel
- For wall mounting with 4 screw-on brackets
- 2 different widths [940 mm and 1,200 mm]
- 1-level to 7-level version available
- Capacity up to 35 pairs of shoes or clogs depending on the model
- Clear shelf height: approx. 250 mm

**WIDTH 940 MM**

TYPE	VERSION	CAPACITY	DIMENSIONS W x D x H in mm	ARTICLE NO.
SWR-1/940	1-level	4 pair	940 x 350 x 285	18.00.01.40
SWR-2/940	2-level	8 pair	940 x 350 x 410	18.00.01.41
SWR-3/940	3-level	12 pairs	940 x 350 x 700	18.00.01.42
SWR-4/940	4-level	16 pairs	940 x 350 x 990	18.00.01.43
SWR-5/940	5-level	20 pairs	940 x 350 x 1280	18.00.01.44
SWR-6/940	6-level	24 pairs	940 x 350 x 1570	18.00.01.45
SWR-7/940	7-level	28 pairs	940 x 350 x 1860	18.00.01.46

**WIDTH 1,200 MM**

TYPE	VERSION	CAPACITY	DIMENSIONS W x D x H in mm	ARTICLE NO.
SWR-1/1200	1-level	5 pair	1200 x 350 x 285	18.00.05.40
SWR-2/1200	2-level	10 pairs	1200 x 350 x 410	18.00.05.41
SWR-3/1200	3-level	15 pairs	1200 x 350 x 700	18.00.05.42
SWR-4/1200	4-level	20 pairs	1200 x 350 x 990	18.00.05.43
SWR-5/1200	5-level	25 pairs	1200 x 350 x 1280	18.00.05.44
SWR-6/1200	6-level	30 pairs	1200 x 350 x 1570	18.00.05.45
SWR-7/1200	7-level	35 pairs	1200 x 350 x 1860	18.00.05.46

**TYPE TSD-II**

## Drying cabinet

STAINLESS STEEL 1.4301



Type TSD-II 20

- Boot/Shoe warm air drying cabinet or clogs
- Welded stainless steel design
- Cabinet body closed on three sides
- Pitched roof, 250 mm higher at the back, in Hygienic-Design
- Roof with exhaust air connection (Ø 100 mm)
- Operator side with 2 smooth hinged doors
- Lockable doors with toggle handle
- Interior with pipe frame construction made of stainless steel
- Stainless steel pipe with anti-burst safety valves for ventilation and Bracket
- Drying via hot air blower
- 4 height-adjustable plastic screw feet (+/- 30 mm)
- Standard ground clearance: 150 mm

TYPE	CAPACITY	DIMENSIONS	ARTICLE NO.
		W x D x H in mm	
TSD-II 10	10 pairs	780 x 700 x 2440	10.00.03.50
TSD-II 15	15 pairs	1035 x 700 x 2440	10.00.03.51
TSD-II 20	20 pairs	1335 x 700 x 2440	10.00.03.52

**TYPE SFS**

## Shoe compartment cabinet

STAINLESS STEEL 1.4301



Type SFS-25 AF VA

- Perfect solution for hygienic storage of your shoes
- Up to 5 compartments, each with 5 stacked compartments
- Pitched roof in hygienic design (200 mm higher at the rear)
- Capacities:
  - 2 x 5 compartment Cabinet: 10 pairs of shoes or clogs
  - 3 x 5 compartment Cabinet: 15 pairs of shoes or clogs
  - 5 x 5 compartment Cabinet: 25 pairs of shoes or clogs
- Compartment clearance: W: 260 x D: 450 x H: 200 mm
- Shoe support made of wire mesh (30 x 30 x 3 mm)
- A removable dirt collection drawer underneath the compartments
- 4 height-adjustable feet (+/- 30 mm),
- Feet indented by 30 mm at the front and rear
- Ground clearance: 150 mm

TYPE	COMP.*	CAPACITY	DIMENSIONS	ARTICLE NO.
			W x D x H in mm	
SFS-10 AF VA	2	10 pairs	610 x 450 x 1630/1830	29.00.00.82
SFS-15 AF VA	3	15 pairs	900 x 450 x 1630/1830	29.00.00.83
SFS-25 AF VA	5	25 pairs	1480 x 450 x 1630/1830	29.00.00.85

\*Compartments

**TYPE STTG HIGHLINE**

# Boot and clog dryer

---



Type STTG-S 1x15





Type STTG-W 30

- Robust highline drying of boots, shoes or clogs
- Hygienic-design in accordance with HACCP
- Robust tubular frame construction made of stainless steel
- Capacity: 10, 15, 20, 30, 40 or 60 pairs of boots, shoes or clogs
- For wall mounting or as a floor model
- Floor model with height-adjustable feet
- Stainless steel tube serves as ventilation and support at the same time
- Drying via hot air blower

**OPTIONS**

Anti-burst safety valve [air vents]	Article no. 16.00.00.05
Ozone generator for disinfection	Article no. 99.90.00.26
Mobile version	Article no. 10.00.02.69
Digital timer	Article no. 16.00.00.19

TYPE	VERSION	CAPACITY	DIMENSIONS W x D x H in mm	ARTICLE NO.
STTG-W 10	wall-mounted	10 pairs	790 x 525 x 2130	10.00.02.23
STTG-W 15	wall-mounted	15 pairs	1090 x 525 x 2130	10.00.02.24
STTG-W 20	wall-mounted	20 pairs	1390 x 525 x 2130	10.00.02.25
STTG-W 30	wall-mounted	30 pairs	1990 x 525 x 2130	10.00.02.71
STTG-W 40	wall-mounted	40 pairs	2700 x 525 x 2130	10.00.02.70
STTG-S 1x10	Floor model	one-sided - 10 pairs	790 x 500 x 2130	10.00.02.26
STTG-S 1x15	Floor model	one-sided - 15 pairs	1090 x 500 x 2130	10.00.02.29
STTG-S 1x20	Floor model	one-sided - 20 pairs	1390 x 500 x 2130	10.00.02.66
STTG-S 1x30	Floor model	one-sided - 30 pairs	1990 x 500 x 2130	10.00.02.64
STTG-S 1x40	Floor model	one-sided - 40 pairs	2700 x 500 x 2130	10.00.02.60
STTG-S 2x10	Floor model	both sides - 20 pairs	790 x 700 x 2130	10.00.02.39
STTG-S 2x15	Floor model	both sides - 30 pairs	1090 x 700 x 2130	10.00.02.67
STTG-S 2x20	Floor model	double-sided - 40 pairs	1500 x 700 x 2130	10.00.02.68
STTG-S 2x30	Floor model	double-sided - 60 pairs	2100 x 700 x 2130	10.00.02.65

**TYPE HST-W**

## Glove dryer

STAINLESS STEEL 1.4301

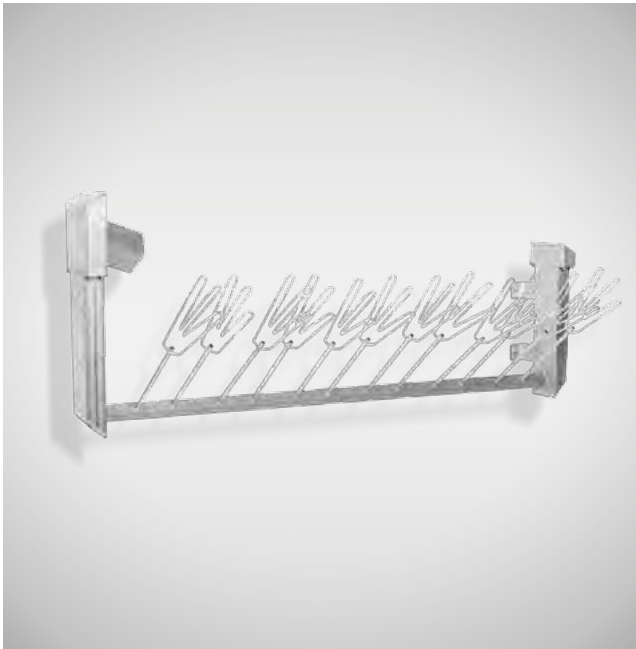

Type HST-W 6

- Energy-saving drying of gloves
- Sturdy pipe frame construction made of 2 mm stainless steel
- Drying model for wall mounting
- Capacity: 6, 12, 18, 24, 30 pairs of gloves
- Glove holder made of Ø 8 mm solid material
- Air nozzles fitted between the holders
- Drying via a 12 V fan [circulating air]

TYPE	VERSION	CAPACITY	DIMENSIONS W x D x H in mm	ARTICLE NO.
HST-W 6	wall-mounted	6 pair	1170 x 428 x 311	10.00.04.09
HST-W 12	wall-mounted	12 pairs	1170 x 428 x 691	10.00.04.10
HST-W 18	wall-mounted	18 pairs	1170 x 428 x 1041	10.00.04.11
HST-W 24	wall-mounted	24 pairs	1170 x 428 x 1391	10.00.04.12
HST-W 30	wall-mounted	30 pairs	1170 x 428 x 1741	10.00.04.13

**OPTIONS**

Numbering	on request
Fastening material	on request

**TYPE HST-S**

## Glove dryer

STAINLESS STEEL 1.4301



Type HST-S 24

- Energy-saving drying of gloves
- Sturdy pipe frame construction made of 2 mm stainless steel
- Floor model version
- Capacity: 18, 24, 30 and 60 pairs of gloves
- Glove holder made of Ø 8 mm solid material
- Air nozzles fitted between the holders
- Drying via a 12 V fan [circulating air]

TYPE	VERSION	CAPACITY	DIMENSIONS W x D x H in mm	ARTICLE NO.
ST-S 18	Floor model	18 pairs	1187 x 485 x 1254	10.00.04.20
HST-S 24	Floor model	24 pairs	1187 x 485 x 1604	10.00.04.21
HST-S 30	Floor model	30 pairs	1187 x 485 x 1816	10.00.04.22
HST-S 60	Floor model	60 pairs	1187 x 800 x 1816	10.00.04.23

**OPTIONS**

Numbering	on request
Height-adjustable feet	on request
Swivel caster set Ø 60 mm, 2 with stop	Article no. 90.00.00.37

**TYPE HST-HF HIGH-FLOW**

# Glove dryer

STAINLESS STEEL 1.4301



Type HST-HF-S 30

- Energy-saving warm air drying of gloves
- Stable pipe frame construction made of stainless steel
- For wall mounting (HST-HF-W) or with base frame for floor mounting (HST-HF-S)
- Capacity: 18, 24, 30 or 60 pairs of gloves
- Phantom hand for gloves made of full material
- Air nozzles fitted between the holders
- Drying via 2 integrated radial heating fans (750 W each)
- Fully welded and cleanly stained design

TYPE	VERSION	CAPACITY	DIMENSIONS W x D x H in mm	ARTICLE NO.
HST-HF-W 18	wall-mounted	18 pairs	1184 x 470 x 1270	10.00.02.50
HST-HF-W 24	wall-mounted	24 pairs	1170 x 437 x 1672	10.00.02.52
HST-HF-W 30	wall-mounted	30 pairs	1184 x 470 x 2095	10.00.02.54
HST-HF-S 18	Stand frame	18 pairs	1185 x 480 x 1317	10.00.02.51
HST-HF-S 24	Stand frame	24 pairs	1185 x 480 x 1680	10.00.02.53
HST-HF-S 30	Stand frame	30 pairs	1185 x 480 x 2142	10.00.02.55
HST-HF-S 60	Stand frame	60 pairs	1185 x 799 x 2142	10.00.02.56



**OPTIONS**

Numbering	on request
Fastening material	on request
OZON generator for Type HST-HF S/W-18	Article no. 10.00.02.59
OZON generator for Type HST-HF S/W-24-60	Article no. 10.00.02.58

4

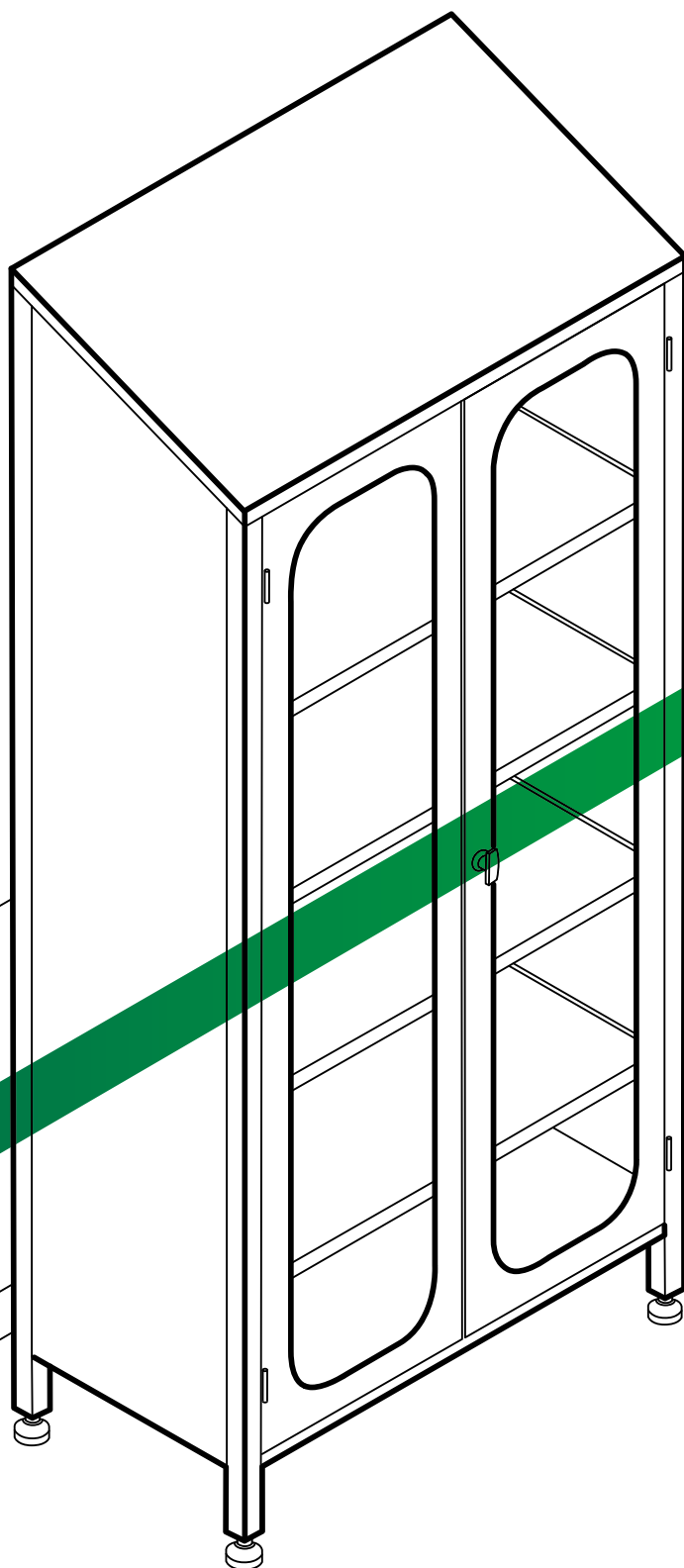

## Factory equipment

Tables and desks

---

Stools and standing aids

---

Cabinets

---

Drawer cabinets and blocks

---

Wall-mounted cabinets

---

Wall-mounted desks and standing desks

---

Workshop trolleys

---

Workshop facilities

---

Storage, compartment cabinets and cleaning cabinets

---

PC and computer cabinets

---

Wall and spice racks

---

Racks

---

Pallet racks

---

**TYPE LA-RF**

# Lifting systems

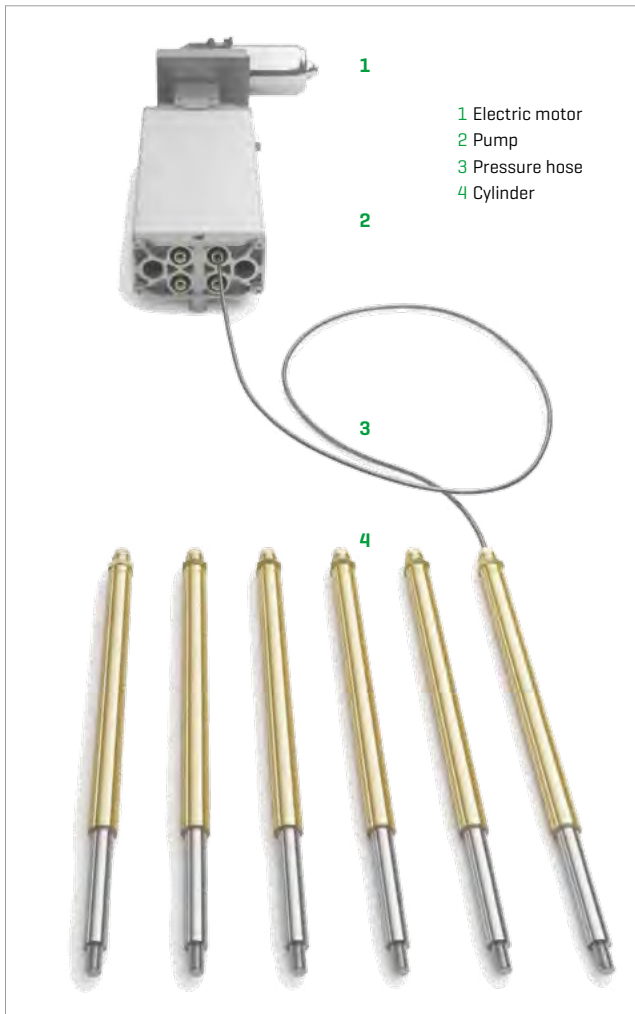

**4 LINEAR UNITS**  
350 kg

TYPE	VERSION 4 linear units -	STROKE LENGTH	HOISTING CAPACITY	ARTICLE NO.
4 LA-M 150/350*	manual	150 mm	350 kg	99.89.91.01
4 LA-M 200/350*	manual	200 mm	350 kg	99.89.91.02
4 LA-M 300/350*	manual	300 mm	350 kg	99.89.91.03
4 LA-M 400/350*	manual	400 mm	350 kg	99.89.91.04
4 LA-M 500/350*	manual	500 mm	350 kg	99.89.91.05
4 LA-M 600/350*	manual	600 mm	350 kg	99.89.91.06
4 LA-M 700/350*	manual	700 mm	350 kg	99.89.91.07
4 LA-E 150/350*	electrical IP 24	150 mm	350 kg	99.89.91.41
4 LA-E 200/350*	electrical IP 24	200 mm	350 kg	99.89.91.42
4 LA-E 300/350*	electrical IP 24	300 mm	350 kg	99.89.91.43
4 LA-E 400/350*	electrical IP 24	400 mm	350 kg	99.89.91.44
4 LA-E 500/350*	electrical IP 24	500 mm	350 kg	99.89.91.45
4 LA-E 600/350*	electrical IP 24	600 mm	350 kg	99.89.91.46
4 LA-E 700/350*	electrical IP 24	700 mm	350 kg	99.89.91.47

**6 LINEAR UNITS**  
600 kg

TYPE	VERSION 6 linear units -	STROKE LENGTH	HOISTING CAPACITY	ARTICLE NO.
6 LA-M 110/600*	manual	110 mm	600 kg	99.89.91.31
6 LA-M 180/600*	manual	180 mm	600 kg	99.89.91.32
6 LA-M 240/600*	manual	240 mm	600 kg	99.89.91.33
6 LA-M 300/600*	manual	300 mm	600 kg	99.89.91.34
6 LA-M 400/600*	manual	400 mm	600 kg	99.89.91.35
6 LA-E 110/600*	electrical IP 24	110 mm	600 kg	99.89.91.71
6 LA-E 180/600*	electrical IP 24	180 mm	600 kg	99.89.91.72
6 LA-E 240/600*	electrical IP 24	240 mm	600 kg	99.89.91.73
6 LA-E 300/600*	electrical IP 24	300 mm	600 kg	99.89.91.74
6 LA-E 400/600*	electrical IP 24	400 mm	600 kg	99.89.91.75

\* LA = Linear units [cylinders]

**4 LINEAR UNITS**  
600 kg

TYPE	VERSION 4 linear units -	STROKE LENGTH	HOISTING CAPACITY	ARTICLE NO.
4 LA-M 110/600*	manual	110 mm	600 kg	99.89.91.11
4 LA-M 180/600*	manual	180 mm	600 kg	99.89.91.12
4 LA-M 240/600*	manual	240 mm	600 kg	99.89.91.13
4 LA-M 300/600* <sup>1</sup>	manual	300 mm	600 kg	99.89.91.14
4 LA-M 400/600* <sup>1</sup>	manual	400 mm	600 kg	99.89.91.15
4 LA-E 110/600*	electrical IP 24	110 mm	600 kg	99.89.91.51
4 LA-E 180/600*	electrical IP 24	180 mm	600 kg	99.89.91.52
4 LA-E 240/600*	electrical IP 24	240 mm	600 kg	99.89.91.53
4 LA-E 300/600*	electrical IP 24	300 mm	600 kg	99.89.91.54
4 LA-E 400/600*	electrical IP 24	400 mm	600 kg	99.89.91.55

**OPTIONS**

Electric motor driven operation	on request
---------------------------------	------------

Height-adjustable liftings systems for every Application purpose!  
For an ergonomic workplace design of tables, cabinets etc.





**SITUATION**

With a share of more than 50%, diseases of the musculoskeletal system are at the forefront of occupational diseases. 35% of absenteeism from the workplace trace back to diseases which are caused due to incorrect posture.

**SOLUTION**

Under the aspect of optimal workplace design, we offer you for the food industry, especially for the meat industry, but also for all other fields, a system with individual height adjustment possibility.

**DESCRIPTION**

The lifting system is a simply acting micro-hydraulic system with decisive advantages compared with conventional systems. Connected via flexible connecting cables, it works precisely, load-independent and completely synchronic. Apart from high-quality workmanship and small dimensions, it also excels by a high load bearing capacity as well as low-noise drive.

The basic systems consists of a pump, cylinders or linear units or table legs with integrated cylinders and a pressure hose [ø 4mm] to connect the elements. The system is driven by a crank or an electric motor.

**6 LINEAR UNITS**  
350 kg

TYPE	VERSION 6 linear units -	STROKE LENGTH	HOISTING CAPACITY	ARTICLE NO.
6 LA-M 150/350*	manual	150 mm	350 kg	99.89.91.21
6 LA-M 200/350*	manual	200 mm	350 kg	99.89.91.22
6 LA-M 300/350*	manual	300 mm	350 kg	99.89.91.23
6 LA-M 400/350*	manual	400 mm	350 kg	99.89.91.24
6 LA-M 500/350*	manual	500 mm	350 kg	99.89.91.25
6 LA-M 600/350*	manual	600 mm	350 kg	99.89.91.26
6 LA-M 700/350*	manual	700 mm	350 kg	99.89.91.27
6 LA-E 150/350*	electrical IP 24	150 mm	350 kg	99.89.91.61
6 LA-E 200/350*	electrical IP 24	200 mm	350 kg	99.89.91.62
6 LA-E 300/350*	electrical IP 24	300 mm	350 kg	99.89.91.63
6 LA-E 400/350*	electrical IP 24	400 mm	350 kg	99.89.91.64
6 LA-E 500/350*	electrical IP 24	500 mm	350 kg	99.89.91.65
6 LA-E 600/350*	electrical IP 24	600 mm	350 kg	99.89.91.66
6 LA-E 700/350*	electrical IP 24	700 mm	350 kg	99.89.91.67



- 1 Work table Type AT-U ERGO, manual
- 2 Work cabinet Type AS-SZ ERGO
- 3 Work table Type AT-U ERGO, electric

- 4 Drive: Manual operation / crank
- 5 Option: Electric motor driven operation

**TYPE AT**  
**Work tables**



Type AT-U



Type AT-H



Type AT-B



WIDTH in mm	TYPE AT-U Height: 850 mm			TYPE AT-H Height: 850 mm			TYPE AT-B Height: 850 mm		
	ARTICLE NO. Depth: 600 mm	ARTICLE NO. Depth: 700 mm	ARTICLE NO. Depth: 800 mm	ARTICLE NO. Depth: 600 mm	ARTICLE NO. Depth: 700 mm	ARTICLE NO. Depth: 800 mm	ARTICLE NO. Depth: 600 mm	ARTICLE NO. Depth: 700 mm	ARTICLE NO. Depth: 800 mm
600	21.00.01.03	21.00.01.38	21.00.11.72	21.00.11.00	21.00.11.24	21.00.11.48	21.00.03.02	21.00.03.37	21.00.31.00
700	21.00.01.04	21.00.01.39	21.00.11.73	21.00.11.01	21.00.11.25	21.00.11.49	21.00.03.03	21.00.03.38	21.00.31.01
800	21.00.01.05	21.00.01.40	21.00.11.74	21.00.11.02	21.00.11.26	21.00.11.50	21.00.03.04	21.00.03.39	21.00.31.02
900	21.00.01.06	21.00.01.41	21.00.11.75	21.00.11.03	21.00.11.27	21.00.11.51	21.00.03.05	21.00.03.40	21.00.31.03
1000	21.00.01.07	21.00.01.42	21.00.11.76	21.00.11.04	21.00.11.28	21.00.11.52	21.00.03.06	21.00.03.41	21.00.31.04
1100	21.00.01.08	21.00.01.43	21.00.11.77	21.00.11.05	21.00.11.29	21.00.11.53	21.00.03.07	21.00.03.42	21.00.31.05
1200	21.00.01.09	21.00.01.44	21.00.11.78	21.00.11.06	21.00.11.30	21.00.11.54	21.00.03.08	21.00.03.43	21.00.31.06
1300	21.00.01.10	21.00.01.45	21.00.11.79	21.00.11.07	21.00.11.31	21.00.11.55	21.00.03.09	21.00.03.44	21.00.31.07
1400	21.00.01.11	21.00.01.46	21.00.11.80	21.00.11.08	21.00.11.32	21.00.11.56	21.00.03.10	21.00.03.45	21.00.31.08
1500	21.00.01.12	21.00.01.47	21.00.11.81	21.00.11.09	21.00.11.33	21.00.11.57	21.00.03.11	21.00.03.46	21.00.31.09
1600	21.00.01.13	21.00.01.48	21.00.11.82	21.00.11.10	21.00.11.34	21.00.11.58	21.00.03.12	21.00.03.47	21.00.31.10
1700	21.00.01.14	21.00.01.49	21.00.11.83	21.00.11.11	21.00.11.35	21.00.11.59	21.00.03.13	21.00.03.48	21.00.31.11
1800	21.00.01.15	21.00.01.50	21.00.11.84	21.00.11.12	21.00.11.36	21.00.11.60	21.00.03.14	21.00.03.49	21.00.31.12
1900	21.00.01.16	21.00.01.51	21.00.11.85	21.00.11.13	21.00.11.37	21.00.11.61	21.00.03.15	21.00.03.50	21.00.31.13
2000	21.00.01.17	21.00.01.52	21.00.11.86	21.00.11.14	21.00.11.38	21.00.11.62	21.00.03.16	21.00.03.51	21.00.31.14
2100	21.00.01.18	21.00.01.53	21.00.11.87	21.00.11.15	21.00.11.39	21.00.11.63	21.00.03.17	21.00.03.52	21.00.31.15
2200	21.00.01.19	21.00.01.54	21.00.11.88	21.00.11.16	21.00.11.40	21.00.11.64	21.00.03.18	21.00.03.53	21.00.31.16
2300	21.00.01.20	21.00.01.55	21.00.11.89	21.00.11.17	21.00.11.41	21.00.11.65	21.00.03.19	21.00.03.54	21.00.31.17
2400	21.00.01.21	21.00.01.56	21.00.11.90	21.00.11.18	21.00.11.42	21.00.11.66	21.00.03.20	21.00.03.55	21.00.31.18
2500	21.00.01.22	21.00.01.57	21.00.11.91	21.00.11.19	21.00.11.43	21.00.11.67	21.00.03.21	21.00.03.56	21.00.31.19
2600	21.00.01.23	21.00.01.58	21.00.11.92	21.00.11.20	21.00.11.44	21.00.11.68	21.00.03.22	21.00.03.57	21.00.31.20
2700	21.00.01.24	21.00.01.59	21.00.11.93	21.00.11.21	21.00.11.45	21.00.11.69	21.00.03.23	21.00.03.58	21.00.31.21
2800	21.00.01.25	21.00.01.60	21.00.11.94	21.00.11.22	21.00.11.46	21.00.11.70	21.00.03.24	21.00.03.59	21.00.31.22
2900	21.00.01.26	21.00.01.61	21.00.11.95	21.00.11.23	21.00.11.47	21.00.11.71	21.00.03.25	21.00.03.60	21.00.31.23



Type AT-R

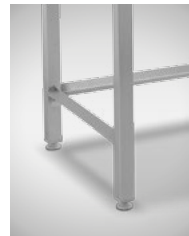

Detail Type AT-U



Detail Type AT-H

<b>TYPE AT-R</b> Height: 850 mm			
<b>WIDTH</b> in mm	<b>ARTICLE NO.</b> Depth: 600 mm	<b>ARTICLE NO.</b> Depth: 700 mm	<b>ARTICLE NO.</b> Depth: 800 mm
600	21.00.04.12	21.00.04.47	21.00.41.00
700	21.00.04.13	21.00.04.48	21.00.41.01
800	21.00.04.14	21.00.04.49	21.00.41.02
900	21.00.04.15	21.00.04.50	21.00.41.03
1000	21.00.04.16	21.00.04.51	21.00.41.04
1100	21.00.04.17	21.00.04.52	21.00.41.05
1200	21.00.04.18	21.00.04.53	21.00.41.06
1300	21.00.04.19	21.00.04.54	21.00.41.07
1400	21.00.04.20	21.00.04.55	21.00.41.08
1500	21.00.04.21	21.00.04.56	21.00.41.09
1600	21.00.04.22	21.00.04.57	21.00.41.10
1700	21.00.04.23	21.00.04.58	21.00.41.11
1800	21.00.04.24	21.00.04.59	21.00.41.12
1900	21.00.04.25	21.00.04.60	21.00.41.13
2000	21.00.04.26	21.00.04.61	21.00.41.14
2100	21.00.04.27	21.00.04.62	21.00.41.15
2200	21.00.04.28	21.00.04.63	21.00.41.16
2300	21.00.04.29	21.00.04.64	21.00.41.17
2400	21.00.04.30	21.00.04.65	21.00.41.18
2500	21.00.04.31	21.00.04.66	21.00.41.19
2600	21.00.04.32	21.00.04.67	21.00.41.20
2700	21.00.04.33	21.00.04.68	21.00.41.21
2800	21.00.04.34	21.00.04.69	21.00.41.22
2900	21.00.04.35	21.00.04.70	21.00.41.23

**WORK TABLES TYPE AT**

- Table top with 1.5 mm material thickness
- Table top chamfered on 3 sides, rear 40 mm flanged (gallery), alternatively: smoothly chamfered on all sides
- Work top underneath reinforced with hat profile, Load up to max. 200 kg [equally distributed load]
- Lower structure with stable square pipe frame construction [40 x 40 x 1.5 mm]
- 4 or 6 height-adjustable plastic screw feet [+/- 30 mm]
- From 2,500 mm length with 6 supporting feet
- Standard ground clearance: 150 mm
- Work table Type AT-U or Type AT-H: Lower structure in the Hygienic Design (diamond profile)

**LOWER STRUCTURE**

- Strutted in U-shape on 3 sides [Type AT-U] - longitudinal strut at the rear
- Strutted in H-shape on 3 sides [Type AT-H] - longitudinal strut centred
- 1 intermediate shelf [Type AT-B]
- 1 storage grate, across [Type AT-R]

**MATERIAL**

- Stainless steel furniture made of chrome-nickel steel 18/10 material No. 1.4301
- The externally visible stainless steel sheet surfaces have a 320 grit polished finish.
- The externally visible stainless steel profile surfaces, such as the table legs, have a uniform brushed finish.



**TYPE AT-U/SL/-R**  
**Work tables**

STAINLESS STEEL 1.4301



**Type AT-U/ SL** Strutted lower structure



**TYPE AT-U/SL**  
 Height: 850 mm

WIDTH in mm	ARTICLE NO. Depth: 600 mm	ARTICLE NO. Depth: 700 mm	ARTICLE NO. Depth: 800 mm
1400	20.00.07.70	20.00.07.77	20.00.07.84
1500	20.00.07.71	20.00.07.78	20.00.07.85
1600	20.00.07.72	20.00.07.79	20.00.07.86
1700	20.00.07.73	20.00.07.80	20.00.07.87
1800	20.00.07.74	20.00.07.81	20.00.07.88
1900	20.00.07.75	20.00.07.82	20.00.07.89
2000	20.00.07.76	20.00.07.83	20.00.07.90

**TYPE AT-U/SR**  
 Height: 850 mm

WIDTH in mm	ARTICLE NO. Depth: 600 mm	ARTICLE NO. Depth: 700 mm	ARTICLE NO. Depth: 800 mm
1400	20.00.08.20	20.00.08.27	20.00.08.34
1500	20.00.08.21	20.00.08.28	20.00.08.35
1600	20.00.08.22	20.00.08.29	20.00.08.36
1700	20.00.08.23	20.00.08.30	20.00.08.37
1800	20.00.08.24	20.00.08.31	20.00.08.38
1900	20.00.08.25	20.00.08.32	20.00.08.39
2000	20.00.08.26	20.00.08.33	20.00.08.40

**WORK TABLES TYPE AT-U/SL AND SR**

- Table top with 1.5 mm material thickness
- Table top chamfered on 3 sides, rear 40 mm flanged [gallery], alternatively: smoothly chamfered on all sides
- Work top underneath reinforced with hat profile, Load up to max. 200 kg [equally distributed load]
- Lower structure with stable square pipe frame construction [40 x 40 x 1.5 mm]
- 6 height-adjustable plastic screw feet [+/- 30 mm]
- Standard ground clearance: 150 mm
- Drawer unit, left [-SL] or right [-SR], consisting of 2 box drawers, W 300 x D 500 x H 150 mm, with partial pull-out
- 1 box drawer, W 300 x D 500 x H 300 mm, with partial pull-out

**LOWER STRUCTURE**

- Lower structure strutted on 2 sides in the Hygienic Design [diamond profile]

**MATERIAL**

- Stainless steel furniture made of chrome-nickel steel 18/10 material No. 1.4301
- The externally visible stainless steel sheet surfaces have a 320 grit polished finish.
- The externally visible stainless steel profile surfaces, such as the table legs, have a uniform brushed finish.

**TYPE AT-B/SL/-R**

**Work tables**

STAINLESS STEEL 1.4301



**Type AT-B/ SL** Lower structure with intermediate shelf



**TYPE AT-B/SL**  
Height: 850 mm

WIDTH in mm	ARTICLE NO. Depth: 600 mm	ARTICLE NO. Depth: 700 mm	ARTICLE NO. Depth: 800 mm
1400	20.00.08.50	20.00.08.57	20.00.08.64
1500	20.00.08.51	20.00.08.58	20.00.08.65
1600	20.00.08.52	20.00.08.59	20.00.08.66
1700	20.00.08.53	20.00.08.60	20.00.08.67
1800	20.00.08.54	20.00.08.61	20.00.08.68
1900	20.00.08.55	20.00.08.62	20.00.08.69
2000	20.00.08.56	20.00.08.63	20.00.08.70

**TYPE AT-B/SR**  
Height: 850 mm

WIDTH in mm	ARTICLE NO. Depth: 600 mm	ARTICLE NO. Depth: 700 mm	ARTICLE NO. Depth: 800 mm
1400	20.00.08.80	20.00.08.87	20.00.08.73
1500	20.00.08.81	20.00.08.88	20.00.08.74
1600	20.00.08.82	20.00.08.89	20.00.08.75
1700	20.00.08.83	20.00.08.90	20.00.08.76
1800	20.00.08.84	20.00.08.91	20.00.08.77
1900	20.00.08.85	20.00.08.92	20.00.08.78
2000	20.00.08.86	20.00.08.93	20.00.08.79

**WORK TABLES TYPE AT-B/ SL AND SR**

- Table top with 1.5 mm material thickness
- Table top chamfered on 3 sides, rear 40 mm flanged [gallery], alternatively: smoothly chamfered on all sides
- Work top underneath reinforced with hat profile, Load up to max. 200 kg [equally distributed load]
- Lower structure with stable square pipe frame construction [40 x 40 x 1.5 mm]
- 6 height-adjustable plastic screw feet [+/- 30 mm]
- Standard ground clearance: 150 mm
- Drawer unit, left [-SL] or right [-SR], consisting of 2 box drawers, W 300 x D 500 x H 150 mm, with partial pull-out
- 1 box drawer, W 300 x D 500 x H 300 mm, with Partial pull-out

**LOWER STRUCTURE**

- 1 intermediate shelf - welded in solidly

**MATERIAL**

- Stainless steel furniture made of chrome-nickel steel 18/10 material No. 1.4301
- The externally visible stainless steel sheet surfaces have a 320 grit polished finish.
- The externally visible stainless steel profile surfaces, such as the table legs, have a uniform brushed finish.

**TYPE AT-U**

## Work tables

---







Type AT-U/STL Drawer unit left, lower structure open



Type AT-U/STR Drawer unit right, lower structure open

**TYPE AT-U/STL**

Height: 730 mm

WIDTH in mm	ARTICLE NO. Depth: 600 mm	ARTICLE NO. Depth: 700 mm	ARTICLE NO. Depth: 800 mm
1400	21.00.01.70	21.00.01.77	21.00.12.00
1500	21.00.01.71	21.00.01.78	21.00.12.01
1600	21.00.01.72	21.00.01.79	21.00.12.02
1700	21.00.01.73	21.00.01.80	21.00.12.03
1800	21.00.01.74	21.00.01.81	21.00.12.04
1900	21.00.01.75	21.00.01.82	21.00.12.05
2000	21.00.01.76	21.00.01.83	21.00.12.06

**TYPE AT-U/STR**

Height: 730 mm

WIDTH in mm	ARTICLE NO. Depth: 600 mm	ARTICLE NO. Depth: 700 mm	ARTICLE NO. Depth: 800 mm
1400	21.00.01.90	21.00.01.97	21.00.02.89
1500	21.00.01.91	21.00.01.98	21.00.02.90
1600	21.00.01.92	21.00.01.99	21.00.02.91
1700	21.00.01.93	21.00.02.00	21.00.02.92
1800	21.00.01.94	21.00.02.01	21.00.02.93
1900	21.00.01.95	21.00.02.02	21.00.02.94
2000	21.00.01.96	21.00.02.03	21.00.02.95

**DESK TYPE AT-U/STL AND STR**

- Table top with 1.5 mm material thickness
- Table top chamfered on 3 sides, rear 40 mm flanged [gallery], alternatively: smoothly chamfered on all sides
- Work top underneath reinforced with hat profile, Load up to max. 200 kg [equally distributed load]
- Lower structure with stable square pipe frame construction [40 x 40 x 1.5 mm]
- 4 height-adjustable plastic screw feet [+/- 30 mm] Standard ground clearance: 150 mm

**DESCRIPTION**

- Drawer unit, left [-STL] or right [-STR], consisting of:
  - 1 box drawer, W 400 x D 500 x H 100 mm, with partial pull-out [2/3]
  - 3 box drawers, W 400 x D 500 x H 135 mm, with partial pull-out [2/3]
- Lower structure, clad with perforated plate on 2 sides

- Table top with cable penetration opening [top left or right]
- Lower structure with PC fitting made of stainless steel

**OPTIONS**

Table top made of HDPE-500, 30 mm thick [different colours]	on request
Drawers with full pull-out made of rust-free stainless steel	on request
Drawers are lockable	on request

**MATERIAL**

- Stainless steel furniture made of chrome-nickel steel 18/10 material No. 1.4301
- The externally visible stainless steel sheet surfaces have a 320 grit polished finish.
- The externally visible stainless steel profile surfaces, such as the table legs, have a uniform brushed finish.

**TYPE HMX / STMX / SMX**

**Stools, seating aids and chairs**

STAINLESS STEEL 1.4301, POLYOLEFIN



Stool Type HMX-310



Seating aid Type STMX-320



Chair Type SMX-330



Stool Type HMX-312



Seating aid Type STMX-322



Chair Type SMX-332

- Suitable for the autoclave
- Ergonomic seat shell made of polyolefin plastic
- High-quality stainless steel column, height-adjustable
- Height adjustment range from 490 - 740 mm or 470 - 720 mm (depending on the type)
- Five-foot stainless steel base frame with sliders (Ø 576 mm)
- With or without foot ring, depending on version

More healthy sitting, relaxing while standing increases performance and stamina!

**STOOL TYPE HMX**

TYPE	FOOT RING	DIMENSIONS D x H mm	ARTICLE NO.
HMX-310	No	Ø 576 x 490 - 740	99.87.02.04
HMX-312	Yes	Ø 576 x 490 - 740	99.87.02.05

**SEATING AID TYPE STMX**

TYPE	FOOT RING	DIMENSIONS D x H mm	ARTICLE NO.
STMX-320	No	Ø 576 x 470 - 720	99.87.02.01
STMX-322	Yes	Ø 576 x 470 - 720	99.87.02.00

**CHAIR TYPE SMX**

TYPE	FOOT RING	DIMENSIONS D x H mm	ARTICLE NO.
SMX-330	No	Ø 576 x 550 - 800	99.87.02.02
SMX-332	Yes	Ø 576 x 550 - 800	99.87.02.03

**TYPE ST-HL**

## Standing aids

STAINLESS STEEL 1.4301, POLYURETHANE



- Ergonomically shaped comfortable seat with steel insert
- Seat made of durable, easy-care integral foam
- Seat height-adjustable from 600 to 850 mm
- Seat inclination, adjustable by 15°, horizontally by 16°, adjustable to any direction
- Seat with automatic resetting device
- Non-slip floor gliders

TYPE	FRAME	DIMENSIONS	ARTICLE NO.
		W x D x H in mm	
ST-HL	Stainless steel	210/ 530 x 420 x 850	40.00.04.44

**TYPE MTS**

**Machine benches**

STAINLESS STEEL 1.4301



Version with strut



Version with intermediate shelf

**FLOOR MODEL IN 2 DIFFERENT VERSIONS**

- Stable, welded industrial version
- Table top, made of stainless steel, in 2 mm material thickness
- Table top, underneath reinforced with surrounding square pipe profile frame
- Load capacity max. 200 kg
- Lower structure, optionally strutted or with intermediate shelf
- Strut in Hygienic-Design diamond profile
- 4 height-adjustable plastic screw feet [ $\pm$  30 mm]
- Standard ground clearance: 150 mm



Detail: Strut

TYPE	VERSION	DIMENSIONS	ARTICLE NO.
		W x D x H in mm	
MTS-VK	Strut	680 x 680 x 850	22.00.11.45
MTS-VG	Strut	850 x 850 x 850	22.00.11.46
MTS-ZK	Intermediate shelf	680 x 680 x 850	22.00.01.45
MTS-ZG	Intermediate shelf	850 x 850 x 850	22.00.01.46

We produce all tables also individually as desired by the customer!

**TYPE MTF**

**Machine benches**

STAINLESS STEEL 1.4301



Version with strut



Version with intermediate shelf

**MOBILE IN 2 DIFFERENT VERSIONS**

- Stable, welded industrial version
- Table top, made of stainless steel, in 2 mm material thickness
- Table top, underneath reinforced with surrounding square pipe profile frame
- Load capacity max. 200 kg
- Lower structure, optionally strutted or with intermediate shelf
- Strut in Hygienic-Design diamond profile
- 4 rubberised swivel casters [Ø 125 mm], 2 with locking mechanism
- Standard ground clearance: 180 mm

TYPE	VERSION	DIMENSIONS	ARTICLE NO.
		W x D x H in mm	
MTF-VK	Strut	680 x 680 x 850	22.00.11.47
MTF-VG	Strut	850 x 850 x 850	22.00.11.48
MTF-ZK	Intermediate shelf	680 x 680 x 850	22.00.01.47
MTF-ZG	Intermediate shelf	850 x 850 x 850	22.00.01.48

**TYPE ATFI**

**Work tables**



**Type ATFI-H** lower structure with H-strut



**Type ATFI-B** lower structure with intermediate shelf

**TYPE ATFI-H**  
Height: 850 mm

WIDTH in mm	ARTICLE NO. Depth: 700 mm	ARTICLE NO. Depth: 800 mm	ARTICLE NO. Depth: 900 mm
1200	22.00.03.16	20.00.03.37	20.00.03.56
1300	22.00.03.17	20.00.03.38	20.00.03.57
1400	22.00.03.18	20.00.03.39	20.00.03.58
1500	22.00.03.19	20.00.03.40	20.00.03.59
1600	22.00.03.20	20.00.03.41	20.00.03.60
1700	22.00.03.21	20.00.03.42	20.00.03.61
1800	22.00.03.29	20.00.03.43	20.00.03.62
1900	22.00.03.23	20.00.03.44	20.00.03.63
2000	22.00.03.24	20.00.03.45	20.00.03.64
2100	22.00.03.25	20.00.03.46	20.00.03.65
2200	22.00.03.26	20.00.03.47	20.00.03.66
2300	22.00.03.27	20.00.03.48	20.00.03.67
2400	22.00.03.28	20.00.03.49	20.00.03.68

**TYPE ATFI-B**  
Height: 850 mm

WIDTH in mm	ARTICLE NO. Depth: 700 mm	ARTICLE NO. Depth: 800 mm	ARTICLE NO. Depth: 900 mm
1200	20.00.01.00	22.00.01.14	22.00.01.69
1300	20.00.01.01	22.00.01.15	22.00.01.70
1400	20.00.01.02	22.00.01.16	22.00.01.71
1500	20.00.01.03	22.00.01.17	22.00.01.72
1600	20.00.01.04	22.00.01.18	22.00.01.73
1700	20.00.01.05	22.00.01.19	22.00.01.74
1800	20.00.01.06	22.00.01.20	22.00.01.75
1900	20.00.01.07	22.00.03.22	22.00.01.76
2000	20.00.01.08	22.00.01.06	22.00.01.77
2100	20.00.01.09	22.00.01.23	22.00.01.78
2200	20.00.01.10	22.00.01.24	22.00.01.79
2300	20.00.01.11	22.00.01.25	22.00.01.80
2400	20.00.01.12	22.00.01.26	22.00.01.81





Type ATFI-R lower structure with storage grate, across



Close-up: Storage grate

We produce all tables also individually as desired by the customer!

**TYPE ATFI-R**

Height: 850 mm

WIDTH in mm	ARTICLE NO. Depth: 700 mm	ARTICLE NO. Depth: 800 mm	ARTICLE NO. Depth: 900 mm
1200	22.00.03.03	20.00.01.13	22.00.03.76
1300	22.00.03.04	20.00.01.14	22.00.03.77
1400	22.00.03.05	20.00.01.15	22.00.03.78
1500	22.00.03.06	20.00.01.16	22.00.03.79
1600	22.00.03.07	20.00.01.17	22.00.03.80
1700	22.00.03.08	20.00.01.18	22.00.03.81
1800	22.00.03.09	20.00.01.19	22.00.03.82
1900	22.00.03.10	20.00.01.20	22.00.03.83
2000	22.00.03.11	20.00.01.21	22.00.03.84
2100	22.00.03.12	20.00.01.22	22.00.03.85
2200	22.00.03.13	20.00.01.23	22.00.03.86
2300	22.00.03.14	20.00.01.24	22.00.03.87
2400	22.00.03.15	20.00.01.25	22.00.03.88

**WORK TABLES TYPE ATFI**

- Table top with 1.5 mm material thickness
- Table top chamfered on all sides, as well as edged
- Table top, underneath reinforced with surrounding square pipe profile frame
- Lower structure with stable square pipe frame construction [40 x 40 x 1.5 mm]
- Supporting feet, shifted inwards on the side and back
- 4 height-adjustable plastic screw feet [+/- 30 mm]
- Standard ground clearance: 150 mm

**LOWER STRUCTURE**

- H-shape strutted in the Hygienic-Design diamond profile [Type ATFI-H]
- 1 intermediate shelf - welded in solidly [Type ATFI-B]
- 1 storage grate, across - welded in solidly [Type ATFI-R]

**MATERIAL**

- Stainless steel furniture made of chrome-nickel steel 18/10 material No. 1.4301
- The externally visible stainless steel sheet surfaces have a 320 grit polished finish.
- The externally visible stainless steel profile surfaces, such as the table legs, have a uniform brushed finish.

**TYPE UTFI**

**Work tables**



**Type UTFI-H** lower structure with H-strut



**Type UTFI-B** lower structure with intermediate shelf

**TYPE UTFI-H**  
Height: 850 mm

WIDTH in mm	ARTICLE NO. Depth: 700 mm	ARTICLE NO. Depth: 800 mm	ARTICLE NO. Depth: 900 mm
1200	22.00.00.63	22.00.00.77	22.00.01.82
1300	22.00.00.64	22.00.00.78	22.00.01.83
1400	22.00.00.65	22.00.00.79	22.00.01.84
1500	22.00.00.66	22.00.00.80	22.00.01.85
1600	22.00.00.67	22.00.00.81	22.00.01.86
1700	22.00.00.68	22.00.00.82	22.00.01.87
1800	22.00.00.69	22.00.00.83	22.00.01.88
1900	22.00.00.70	22.00.00.84	22.00.01.89
2000	22.00.00.71	22.00.00.85	22.00.01.90
2100	22.00.00.72	22.00.00.86	22.00.01.91
2200	22.00.00.73	22.00.00.87	22.00.01.92
2300	22.00.00.74	22.00.00.88	22.00.01.93
2400	22.00.00.75	22.00.00.89	22.00.01.94

**TYPE UTFI-B**  
Height: 850 mm

WIDTH in mm	ARTICLE NO. Depth: 700 mm	ARTICLE NO. Depth: 800 mm	ARTICLE NO. Depth: 900 mm
1200	22.00.02.02	22.00.02.15	22.00.02.35
1300	22.00.02.03	22.00.02.16	22.00.02.36
1400	22.00.02.04	22.00.02.17	22.00.02.37
1500	22.00.02.05	22.00.02.18	22.00.02.38
1600	22.00.02.06	22.00.02.19	22.00.02.39
1700	22.00.02.07	22.00.02.20	22.00.02.40
1800	22.00.02.08	22.00.02.21	22.00.02.41
1900	22.00.02.09	22.00.02.22	22.00.02.42
2000	22.00.02.10	22.00.02.23	22.00.02.43
2100	22.00.02.11	22.00.02.24	22.00.02.44
2200	22.00.02.12	22.00.02.25	22.00.02.45
2300	22.00.02.13	22.00.02.26	22.00.02.46
2400	22.00.02.14	22.00.02.27	22.00.02.47



Type UTFI-R lower structure with storage grate, across



Close-up: Storage grate

We produce all tables also individually as desired by the customer!

**TYPE UTFI-R**

Height: 850 mm

WIDTH in mm	ARTICLE NO. Depth: 700 mm	ARTICLE NO. Depth: 800 mm	ARTICLE NO. Depth: 900 mm
1200	22.00.03.50	22.00.03.63	22.00.30.26
1300	22.00.03.51	22.00.03.64	22.00.30.27
1400	22.00.03.52	22.00.03.65	22.00.30.28
1500	22.00.03.53	22.00.03.66	22.00.30.29
1600	22.00.03.54	22.00.03.67	22.00.30.30
1700	22.00.03.55	22.00.03.68	22.00.30.31
1800	22.00.03.56	22.00.03.69	22.00.30.32
1900	22.00.03.57	22.00.03.70	22.00.30.33
2000	22.00.03.58	22.00.03.71	22.00.30.34
2100	22.00.03.59	22.00.03.72	22.00.30.35
2200	22.00.03.60	22.00.03.73	22.00.30.36
2300	22.00.03.61	22.00.03.74	22.00.30.37
2400	22.00.03.62	22.00.03.75	22.00.30.38

**WORK TABLE TYPE UTFI**

- Version as Type ATFI, but:
- Plastic cutting plate [HDPE-500] inserted in stainless steel frame
- Plastic cutting plate in 30 mm material thickness
- Colour of the plastic cutting plate in white [standard]; also available in red-brown without additional charge, or in blue, for example, against additional charge

**LOWER STRUCTURE**

- H-shape strutted in the Hygienic-Design diamond profile [Type UTFI-H]
- 1 intermediate shelf - welded in solidly [Type UTFI-B]
- 1 storage grate, across - welded in solidly [Type UTFI-R]

**MATERIAL**

- Stainless steel furniture made of chrome-nickel steel 18/10 material No. 1.4301
- The externally visible stainless steel sheet surfaces have a 320 grit polished finish.
- The externally visible stainless steel profile surfaces, such as the table legs, have a uniform brushed finish.

**OPTIONS**

PE cutting plate in red-brown

Article no. 22.00.02.50

**TYPE WRT**

**Beaded edge tables**



**Type WRT-H** lower structure with H-strut



**Type WRT-B** lower structure with intermediate shelf

**TYPE WRT-H**  
Height: 850 mm

WIDTH in mm	ARTICLE NO. Depth: 900 mm	ARTICLE NO. Depth: 1,000 mm	ARTICLE NO. Depth: 1,100 mm
1400	20.00.04.46	20.00.04.00	20.00.04.81
1500	20.00.04.47	20.00.04.01	20.00.04.82
1600	20.00.04.48	20.00.04.02	20.00.04.83
1700	20.00.04.49	20.00.04.03	20.00.04.84
1800	20.00.04.50	20.00.04.04	20.00.04.85
1900	20.00.04.51	20.00.04.05	20.00.04.86
2000	20.00.04.52	20.00.04.06	20.00.04.87
2100	20.00.04.53	20.00.04.07	20.00.04.88
2200	20.00.04.54	20.00.04.08	20.00.04.89
2300	20.00.04.55	20.00.04.09	20.00.04.90
2400	20.00.04.56	20.00.04.10	20.00.04.91

**TYPE WRT-B**  
Height: 850 mm

WIDTH in mm	ARTICLE NO. Depth: 900 mm	ARTICLE NO. Depth: 1,000 mm	ARTICLE NO. Depth: 1,100 mm
1400	20.00.04.21	20.00.04.60	20.00.40.00
1500	20.00.04.22	20.00.04.61	20.00.40.01
1600	20.00.04.23	20.00.04.62	20.00.40.02
1700	20.00.04.24	20.00.04.63	20.00.40.03
1800	20.00.04.25	20.00.04.64	20.00.40.04
1900	20.00.04.26	20.00.04.65	20.00.40.05
2000	20.00.04.27	20.00.04.66	20.00.40.06
2100	20.00.04.28	20.00.04.67	20.00.40.07
2200	20.00.04.29	20.00.04.68	20.00.40.08
2300	20.00.04.30	20.00.04.69	20.00.40.09
2400	20.00.04.31	20.00.04.70	20.00.40.10



Type WRT-R Lower structure with storage grate, across



Close-up: Storage grate

We produce all tables also individually as desired by the customer!

**TYPE WRT-R**

Height: 850 mm

WIDTH in mm	ARTICLE NO. Depth: 900 mm	ARTICLE NO. Depth: 1,000 mm	ARTICLE NO. Depth: 1,100 mm
1400	20.00.04.11	20.00.04.32	20.00.40.11
1500	20.00.04.12	20.00.04.33	20.00.40.12
1600	20.00.04.13	20.00.04.34	20.00.40.13
1700	20.00.04.14	20.00.04.35	20.00.40.14
1800	20.00.04.15	20.00.04.36	20.00.40.15
1900	20.00.04.16	20.00.04.37	20.00.40.16
2000	20.00.04.17	20.00.04.38	20.00.40.17
2100	20.00.04.18	20.00.04.39	20.00.40.18
2200	20.00.04.19	20.00.04.40	20.00.40.19
2300	20.00.04.20	20.00.04.41	20.00.40.20
2400	20.00.04.80	20.00.04.42	20.00.40.21

**BEADED EDGE TABLE TYPE WRT**

- Table top with 1.5 mm material thickness
- Table top with surrounding beaded edging, with discharge opening on the back left
- Table top, underneath reinforced with surrounding square pipe profile frame
- Lower structure with stable square pipe frame construction [40 x 40 x 1.5 mm]
- Supporting feet, shifted inwards on the side and back
- 4 height-adjustable plastic screw feet [+/- 30 mm]
- Standard ground clearance: 150 mm

**LOWER STRUCTURE**

- H-shape strutted in the Hygienic-Design diamond profile [Type WRT-H]
- 1 intermediate shelf - welded in solidly [Type WRT-B]
- 1 storage grate, across - welded in solidly [Type WRT-R]

**MATERIAL**

- Stainless steel furniture made of chrome-nickel steel 18/10 material No. 1.4301
- The externally visible stainless steel sheet surfaces have a 320 grit polished finish.
- The externally visible stainless steel profile surfaces, such as the table legs, have a uniform brushed finish.

**TYPE FT**  
**Filling tables**



**Type FT-H** lower structure with H-strut



**Type FT-B** lower structure with intermediate shelf

**TYPE FT-H**  
 Height: 850 mm

WIDTH in mm	ARTICLE NO. Depth: 900 mm	ARTICLE NO. Depth: 1,000 mm	ARTICLE NO. Depth: 1,100 mm
1400	20.00.05.00	20.00.05.15	20.00.05.30
1500	20.00.05.01	20.00.05.16	20.00.05.31
1600	20.00.05.02	20.00.05.17	20.00.05.32
1700	20.00.05.03	20.00.05.18	20.00.05.33
1800	20.00.05.04	20.00.05.19	20.00.05.34
1900	20.00.05.05	20.00.05.20	20.00.05.35
2000	20.00.05.06	20.00.05.21	20.00.05.36
2100	20.00.05.07	20.00.05.22	20.00.05.37
2200	20.00.05.08	20.00.05.23	20.00.05.38
2300	20.00.05.09	20.00.05.24	20.00.05.39
2400	20.00.05.10	20.00.05.25	20.00.05.40

**TYPE FT-B**  
 Height: 850 mm

WIDTH in mm	ARTICLE NO. Depth: 900 mm	ARTICLE NO. Depth: 1,000 mm	ARTICLE NO. Depth: 1,100 mm
1400	20.00.09.00	20.00.09.11	20.00.09.63
1500	20.00.09.01	20.00.09.12	20.00.09.64
1600	20.00.09.02	20.00.09.13	20.00.09.65
1700	20.00.09.03	20.00.09.14	20.00.09.66
1800	20.00.09.04	20.00.09.15	20.00.09.67
1900	20.00.09.05	20.00.09.16	20.00.09.68
2000	20.00.09.06	20.00.09.17	20.00.09.69
2100	20.00.09.07	20.00.09.18	20.00.09.70
2200	20.00.09.08	20.00.09.19	20.00.09.71
2300	20.00.09.09	20.00.09.20	20.00.09.72
2400	20.00.09.10	20.00.09.21	20.00.09.73





**Type FT-R** Lower structure with storage grate, across



Close-up: Storage grate

We produce all tables also individually as desired by the customer!

**TYPE FT-R**

Height: 850 mm

WIDTH in mm	ARTICLE NO. Depth: 900 mm	ARTICLE NO. Depth: 1,000 mm	ARTICLE NO. Depth: 1,100 mm
1400	20.00.09.30	20.00.09.41	20.00.09.52
1500	20.00.09.31	20.00.09.42	20.00.09.53
1600	20.00.09.32	20.00.09.43	20.00.09.54
1700	20.00.09.33	20.00.09.44	20.00.09.55
1800	20.00.09.34	20.00.09.45	20.00.09.56
1900	20.00.09.35	20.00.09.46	20.00.09.57
2000	20.00.09.36	20.00.09.47	20.00.09.58
2100	20.00.09.37	20.00.09.48	20.00.09.59
2200	20.00.09.38	20.00.09.49	20.00.09.60
2300	20.00.09.39	20.00.09.50	20.00.09.61
2400	20.00.09.40	20.00.09.51	20.00.09.62

**FILLING TABLE TYPE FT**

- Execution as beaded edge table Type WRT, but:
- Table top partly with beaded edge at the front and sides
- Table top, otherwise with 100 mm flanged
- Table top, with discharge opening on the back left

**LOWER STRUCTURE**

- H-shape strutted in the Hygienic-Design diamond profile (Type FT-H)
- 1 intermediate shelf - welded in solidly (Type FT-B)
- 1 storage grate, across - welded in solidly (Type FT-R)

**MATERIAL**

- Stainless steel furniture made of chrome-nickel steel 18/10 material No. 1.4301
- The externally visible stainless steel sheet surfaces have a 320 grit polished finish.
- The externally visible stainless steel profile surfaces, such as the table legs, have a uniform brushed finish.

**TYPE SAH**

**Stage work tables**



**Type SAH-H** lower structure with H-strut



**Type SAH-B** lower structure with intermediate shelf

**TYPE SAH-H**  
Height: 850 mm

WIDTH in mm	ARTICLE NO. Depth: 700 mm	ARTICLE NO. Depth: 800 mm	ARTICLE NO. Depth: 900 mm
1200	20.00.01.46	20.00.01.31	20.00.06.00
1300	20.00.01.47	20.00.01.32	20.00.06.01
1400	20.00.01.48	20.00.01.33	20.00.06.02
1500	20.00.01.49	20.00.01.34	20.00.06.03
1600	20.00.01.50	20.00.01.35	20.00.06.04
1700	20.00.01.51	20.00.01.36	20.00.06.05
1800	20.00.01.52	20.00.01.37	20.00.06.06
1900	20.00.01.53	20.00.01.38	20.00.06.07
2000	20.00.01.54	20.00.01.39	20.00.06.08
2100	20.00.01.55	20.00.01.40	20.00.06.09
2200	20.00.01.56	20.00.01.41	20.00.06.10
2300	20.00.01.57	20.00.01.42	20.00.06.11
2400	20.00.01.58	20.00.01.43	20.00.06.12

**TYPE SAH-B**  
Height: 850 mm

WIDTH in mm	ARTICLE NO. Depth: 700 mm	ARTICLE NO. Depth: 800 mm	ARTICLE NO. Depth: 900 mm
1200	20.00.06.66	20.00.06.44	20.00.06.23
1300	20.00.06.67	20.00.06.45	20.00.06.24
1400	20.00.06.68	20.00.06.46	20.00.06.25
1500	20.00.06.69	20.00.06.47	20.00.06.26
1600	20.00.06.70	20.00.06.48	20.00.06.27
1700	20.00.06.71	20.00.06.49	20.00.06.28
1800	20.00.06.72	20.00.06.50	20.00.06.29
1900	20.00.06.73	20.00.06.51	20.00.06.30
2000	20.00.06.74	20.00.06.52	20.00.06.31
2100	20.00.06.75	20.00.06.53	20.00.06.32
2200	20.00.06.76	20.00.06.54	20.00.06.33
2300	20.00.06.77	20.00.06.55	20.00.06.34
2400	20.00.06.78	20.00.06.56	20.00.06.35



**Type SAH-H 120-70** Highline

 **SAH-HIGHLINE INFO**



**Type SAH-R** Lower structure with storage grate, across



Close-up: Folding of the upstand

We produce all tables also individually as desired by the customer!

**STAGE WORK TABLE TYPE SAH**

- Stainless table top with rear 100 mm flanged in 1.5 mm material thickness
- Backsplash with rear and bottom edge
- Table top, underneath reinforced with surrounding square pipe profile frame
- Incorporated step, dimension D: 400 x S: 30 mm
- Plastic cutting plate [HDPE-500] on the front, inserted in stainless steel frame
- Plastic cutting plate in 30 mm material thickness
- Colour of the plastic cutting plate in white [standard]; also available in red-brown without additional charge, or in blue, for example, against additional charge
- Lower structure with stable square pipe frame construction [40 x 40 x 1.5 mm]
- Supporting feet, 100 mm shifted inwards on the side and back
- 4 height-adjustable plastic screw feet [+/- 30 mm]
- Standard ground clearance: 150 mm

**LOWER STRUCTURE**

- H-shape strutted in the Hygienic-Design diamond profile [Type SAH-H]
- 1 intermediate shelf - welded in solidly [Type SAH-B]
- 1 storage grate, across - welded in solidly [Type SAH-R]

**MATERIAL**

- Stainless steel furniture made of chrome-nickel steel 18/10 material No. 1.4301
- The externally visible stainless steel sheet surfaces have a 320 grit polished finish.
- The externally visible stainless steel profile surfaces, such as the table legs, have a uniform brushed finish.

**OPTIONS**

PE cutting plate in red-brown	Article no. 22.00.02.50
Other colours	on request

**TYPE SAH-R**

Height: 850 mm

WIDTH in mm	ARTICLE NO. Depth: 700 mm	ARTICLE NO. Depth: 800 mm	ARTICLE NO. Depth: 900 mm
1200	20.00.06.36	20.00.06.13	20.00.01.44
1300	20.00.06.37	20.00.06.14	20.00.01.45
1400	20.00.06.38	20.00.06.15	20.00.01.62
1500	20.00.06.39	20.00.06.16	20.00.01.63
1600	20.00.06.40	20.00.06.17	20.00.01.64
1700	20.00.06.41	20.00.06.18	20.00.01.65
1800	20.00.06.42	20.00.06.19	20.00.01.66
1900	20.00.06.43	20.00.06.20	20.00.06.62
2000	20.00.06.57	20.00.06.21	20.00.06.63
2100	20.00.06.58	20.00.06.22	20.00.06.64
2200	20.00.06.59	20.00.01.67	20.00.06.65
2300	20.00.06.60	20.00.01.68	20.00.06.79
2400	20.00.06.61	20.00.01.69	20.00.06.80

**TYPE SAD**

**Stage work tables**



**Type SAD-H** lower structure with H-strut



**Type SAD-B** lower structure with intermediate shelf

**TYPE SAD-H**  
Height: 850 mm

WIDTH in mm	ARTICLE NO. Depth: 700 mm	ARTICLE NO. Depth: 800 mm	ARTICLE NO. Depth: 900 mm
1200	22.00.04.00	22.00.04.13	22.00.04.26
1300	22.00.04.01	22.00.04.14	22.00.04.27
1400	22.00.04.02	22.00.04.15	22.00.04.28
1500	22.00.04.03	22.00.04.16	22.00.04.29
1600	22.00.04.04	22.00.04.17	22.00.04.30
1700	22.00.04.05	22.00.04.18	22.00.04.31
1800	22.00.04.06	22.00.04.19	22.00.04.32
1900	22.00.04.07	22.00.04.20	22.00.04.33
2000	22.00.04.08	22.00.04.21	22.00.04.34
2100	22.00.04.09	22.00.04.22	22.00.04.35
2200	22.00.04.10	22.00.04.23	22.00.04.36
2300	22.00.04.11	22.00.04.24	22.00.04.37
2400	22.00.04.12	22.00.04.25	22.00.04.38

**TYPE SAD-B**  
Height: 850 mm

WIDTH in mm	ARTICLE NO. Depth: 700 mm	ARTICLE NO. Depth: 800 mm	ARTICLE NO. Depth: 900 mm
1200	22.00.04.39	22.00.04.54	22.00.04.67
1300	22.00.04.40	22.00.04.55	22.00.04.68
1400	22.00.04.41	22.00.04.56	22.00.04.69
1500	22.00.04.42	22.00.04.57	22.00.04.70
1600	22.00.04.43	22.00.04.58	22.00.04.71
1700	22.00.04.44	22.00.04.59	22.00.04.72
1800	22.00.04.47	22.00.04.60	22.00.04.73
1900	22.00.04.48	22.00.04.61	22.00.04.74
2000	22.00.04.49	22.00.04.62	22.00.04.75
2100	22.00.04.50	22.00.04.63	22.00.04.76
2200	22.00.04.51	22.00.04.64	22.00.04.77
2300	22.00.04.52	22.00.04.65	22.00.04.78
2400	22.00.04.53	22.00.04.66	22.00.04.79



**Type SAH-H 120-70** Highline





**Type SAD-R** Lower structure with storage grate, across



Close-up: Lateral upstand, bevelled

We produce all tables also individually as desired by the customer!

**TYPE SAD-R**

Height: 850 mm

WIDTH in mm	ARTICLE NO. Depth: 700 mm	ARTICLE NO. Depth: 800 mm	ARTICLE NO. Depth: 900 mm
1200	22.00.04.80	22.00.04.93	22.00.05.06
1300	22.00.04.81	22.00.04.94	22.00.05.07
1400	22.00.04.82	22.00.04.95	22.00.05.08
1500	22.00.04.83	22.00.04.96	22.00.05.09
1600	22.00.04.84	22.00.04.97	22.00.05.10
1700	22.00.04.85	22.00.04.98	22.00.05.11
1800	22.00.04.86	22.00.04.99	22.00.05.12
1900	22.00.04.87	22.00.05.00	22.00.05.13
2000	22.00.04.88	22.00.05.01	22.00.05.14
2100	22.00.04.89	22.00.05.02	22.00.05.15
2200	22.00.04.90	22.00.05.03	22.00.05.16
2300	22.00.04.91	22.00.05.04	22.00.05.17
2400	22.00.04.92	22.00.05.05	22.00.05.18

**STAGE WORK TABLE TYPE SAD**

- Stainless table top with 3-side backsplash up to the step [100 mm]
- Table top, underneath reinforced with surrounding square pipe profile frame
- Incorporated step, dimension D: 400 x S: 30 mm
- Plastic cutting plate [HDPE-500] on the front, inserted in stainless steel frame
- Plastic cutting plate in 30 mm material thickness
- Colour of the plastic cutting plate in white [standard]; also available in red-brown without additional charge, or in blue, for example, against additional charge
- Lower structure with stable square pipe frame construction [40 x 40 x 1.5 mm]
- Supporting feet, 100 mm shifted inwards on the side and back
- 4 height-adjustable plastic screw feet [+/- 30 mm]
- Standard ground clearance: 150 mm

**LOWER STRUCTURE**

- H-shape strutted in the Hygienic-Design diamond profile [Type SAD-H]
- 1 intermediate shelf - welded in solidly [Type SAD-B]
- 1 storage grate, across - welded in solidly [Type SAD-R]

**MATERIAL**

- Stainless steel furniture made of chrome-nickel steel 18/10 material No. 1.4301
- The externally visible stainless steel sheet surfaces have a 320 grit polished finish.
- The externally visible stainless steel profile surfaces, such as the table legs, have a uniform brushed finish.

**OPTIONS**

PE cutting plate in red-brown	Article no. 22.00.02.50
Other colours	on request

**TYPE DST**

# Double-stage work table



**Type DST-H** lower structure with H-strut



**Type DST-B** lower structure with intermediate shelf

**TYPE DST-H**  
Height: 850 mm

DEPTH in mm	WIDTH in mm	ARTICLE NO.
1200	1200	22.00.05.20
	1300	22.00.05.21
	1400	22.00.05.22
	1500	22.00.05.23
	1600	22.00.05.24
	1700	22.00.05.25
	1800	22.00.05.26
	1900	22.00.05.27
	2000	22.00.05.28
	2100	22.00.05.29
	2200	22.00.05.30
	2300	22.00.05.31
	2400	22.00.05.32

**TYPE DST-B**  
Height: 850 mm

DEPTH in mm	WIDTH in mm	ARTICLE NO.
1200	1200	22.00.05.33
	1300	22.00.05.34
	1400	22.00.05.35
	1500	22.00.05.36
	1600	22.00.05.37
	1700	22.00.05.38
	1800	22.00.05.39
	1900	22.00.05.40
	2000	22.00.05.41
	2100	22.00.05.42
	2200	22.00.05.43
	2300	22.00.05.44
	2400	22.00.05.45

**TYPE DST-R**  
Height: 850 mm

DEPTH in mm	WIDTH in mm	ARTICLE NO.
1200	1200	22.00.05.46
	1300	22.00.05.47
	1400	22.00.05.48
	1500	22.00.05.49
	1600	22.00.05.50
	1700	22.00.05.51
	1800	22.00.05.52
	1900	22.00.05.53
	2000	22.00.05.54
	2100	22.00.05.55
	2200	22.00.05.56
	2300	22.00.05.57
	2400	22.00.05.58



**Type DST Highline**

 **DST-HIGHLINE INFO**





**Type DST-R** Lower structure with storage grate, across

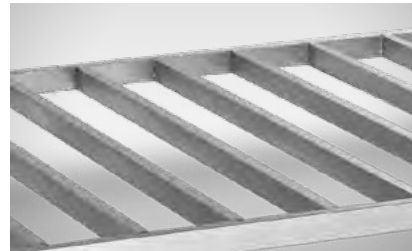

Close-up: Storage grate

We produce all tables also individually as desired by the customer!

**OPTIONS**

Manual or electric height adjustment [ERGO]	on request
Underbuilt box drawer, W: 400 x D: 500 x H: 200 mm	on request
Underbuilt box drawer, W: 400 x D: 500 x H: 200 mm	
Lockable	on request
Drawers with full pull-out	on request
Lower structure with storage grate, longitudinal	on request
Mobile version [2 rigid casters and 2 swivel casters with locking mechanism], Ø125 mm	Article no. 99.90.01.50
Retrofitting set "Expander" [2 rigid casters and 2 swivel casters with locking mechanism], for profile 40 x 40 x 1.5 mm	Article no. 99.90.01.99

**DOUBLE-STAGE WORK TABLE TYPE DST**

- Can be operated on both sides
- Stainless steel table top in 2 mm material thickness
- 2 incorporated steps in dimension [D: 400 x S: 30 mm]
- 2 or 4 cutting plates on the operator side [HDPE-500] inserted in stainless steel frame
- Plastic cutting plate in 30 mm material thickness
- Colour of the plastic cutting plate in white [standard]; also available in red-brown without additional charge, or in blue, for example, against additional charge
- Lower structure with stable square pipe frame construction [40 x 40 x 1.5 mm]
- Supporting feet, 100 mm shifted inwards on the side and back
- 4 height-adjustable plastic screw feet [+/- 30 mm]
- Standard ground clearance: 150 mm

**LOWER STRUCTURE**

- H-shape strutted in the Hygienic-Design - diamond profile [Type DST-H]
- 1 intermediate shelf - welded in solidly [Type DST-B]
- 1 storage grate, across - welded in solidly [Type DST-R]

**MATERIAL**

- Stainless steel furniture made of chrome-nickel steel 18/10 material No. 1.4301
- The externally visible stainless steel sheet surfaces have a 320 grit polished finish.
- The externally visible stainless steel profile surfaces, such as the table legs, have a uniform brushed finish.

**OPTIONS**

PE cutting plate in red-brown	Article no. 22.00.02.50
Other colours	on request

**TYPE SAH-H / DST-H**

## Stage work tables



**Type SAH-H 120-70 HL** Substructure with H-bracing



**Type DST-H 120-120 HL** Substructure with H-bracing

### STAGE WORK TABLE HIGHLINE, TYPE SAH-H

Ergonomic stage work table made from hygienic round steel

- Welded stainless steel design
- Stainless table top with rear 100 mm flanged in 1.5 mm material thickness
- Stainless steel table top reinforced underneath with all-round square tubular profile frame
- Incorporated step, dimension D: 400 x S: 30 mm
- Plastic cutting plate (HDPE-500) inserted in hygienic round tube frame  $\varnothing 42.4 \times 1.5$  mm at the front
- Round tube frame with special device for ergonomic positioning of the HDPE cutting plate during the cleaning process
- Plastic cutting plate in 30 mm material thickness
- Colour of the plastic cutting plate white [standard]; also available in red-brown at no extra charge or coloured e.g. blue at an extra charge
- Pedestal base with stable square tubular frame construction [40 x 40 x 1.5 mm]
- Supporting feet, 100 mm shifted inwards on the side and back
- 4 height-adjustable plastic screw feet [+/- 30 mm]
- H-shaped strut in Hygienic Design round tube profile  $\varnothing 25 \times 1.5$  mm
- Standard ground clearance: 150 mm

 [MORE SAH-H INFO](#)

### HIGHLINE DOUBLE STAGE WORK TABLE, TYPE DST-H

Ergonomic stage work table made of hygienic round steel that can be operated from both sides

- Welded stainless steel design
- Stainless steel table top in 2 mm material thickness
- Stainless steel table top underneath with all-round square tubing profile frame reinforced
- 2 integrated steps measuring D 400 x T 30 mm
- 2 or 4 plastic cutting plates (HDPE-500) inserted on the operator side in hygienic round tube frame  $\varnothing 42.4 \times 1.5$  mm
- Round tube frame with special device for ergonomic positioning of the HDPE cutting plate during the cleaning process
- Plastic cutting inserts in 30 mm material thickness
- Colour of the plastic cutting plate white [standard]; also available in red-brown at no extra charge or coloured e.g. blue at an extra charge
- Pedestal base with stable square tubular frame construction [40 x 40 x 1.5 mm]
- Supporting feet, 100 mm shifted inwards on the side and back
- 4 or 6 height-adjustable plastic screw feet [+/- 30 mm]
- H-shaped strut in Hygienic Design round tube profile  $\varnothing 25 \times 1.5$  mm
- Standard ground clearance: 150 mm

 [MORE DST-H INFO](#)

**TYPE ZST**

# Butchering and sorting tables

STAINLESS STEEL 1.4301, HDPE 500



**Type ZST-1**, 2 to 6 drop chutes, can be operated from one side



**Type ZST-2**, 4 to 12 drop chutes, can be operated on two sides

**TYPE ZST-1**  
Height: 850 mm

DEPTH in mm	WIDTH in mm	DROP CHUTES	ARTICLE NO.
900	1200	2	20.00.22.96
	1600	3	20.00.22.97
	2000	4	20.00.22.98
	2400	5	20.00.22.99
	3000	6	20.00.23.00

**TYPE ZST-2**  
Height: 850 mm

DEPTH in mm	WIDTH in mm	DROP CHUTES	ARTICLE NO.
1800	1200	4	20.00.23.01
	1600	6	20.00.23.02
	2000	8	20.00.23.03
	2400	10	20.00.23.04
	3000	12	20.00.23.05

**BUTCHERING AND SORTING TABLES TYPE ZST**

- Stainless table top with rear 100 mm flanged (Type ZST-1)
- 2 to 6 (Type ZST-1) or 4 to 12 drop chutes with baffles (Type ZST-2)
- 1 intermediate shelf - welded in solidly, inclined downwards to the operator side inclined (Type ZST-1 + ZST-2)
- Centred, stainless steel table top in 2 mm material thickness, with: 2 incorporated steps in dimension (D: 400 x S: 30 mm)
- 2 or 4 cutting plates on the operator side (HDPE-500) inserted in stainless steel frame
- Plastic cutting plate in 30 mm material thickness
- Colour of the plastic cutting plate in white (standard); also available in red-brown without additional charge, or in blue, for example, against additional charge
- Lower structure with stable square pipe frame construction (40 x 40 x 1.5 mm)

- Supporting feet, 100 mm shifted inwards on the side and back
- With height-adjustable plastic screw feet (+/- 30 mm)
- Standard ground clearance: 150 mm

**OPTIONS**

Manual height adjustment (ERGO), only Type ZST-1	on request
PE cutting plate in red-brown	Article no. 22.00.02.50
Other colours	on request

**MATERIAL**

- Stainless steel furniture made of chrome-nickel steel 18/10 material No. 1.4301
- The externally visible stainless steel sheet surfaces have a 320 grit polished finish.
- The externally visible stainless steel profile surfaces, such as the table legs, have a uniform brushed finish.

## Work tables as desired by the customer

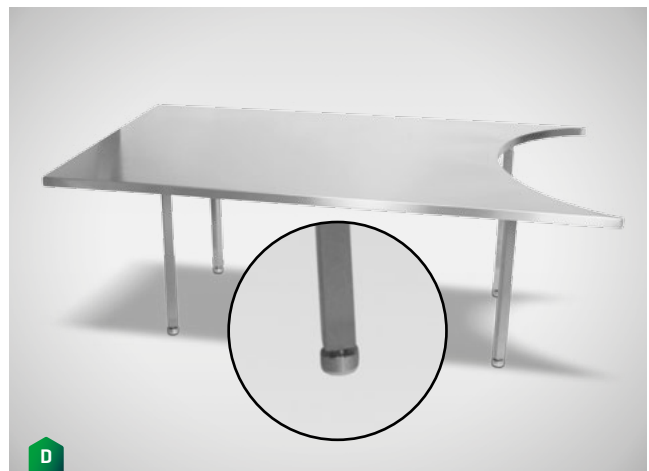
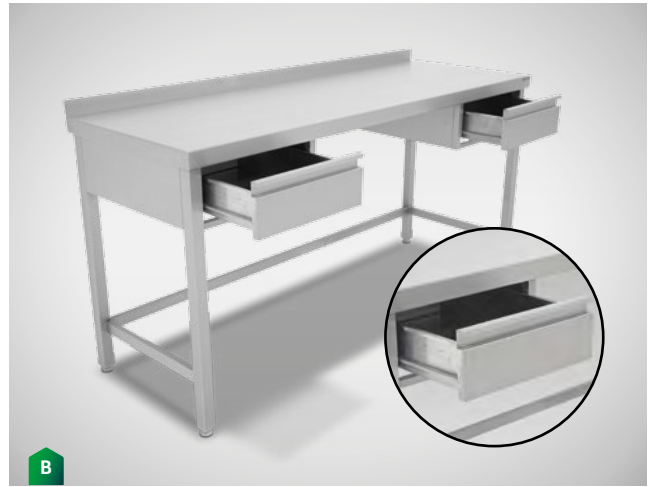
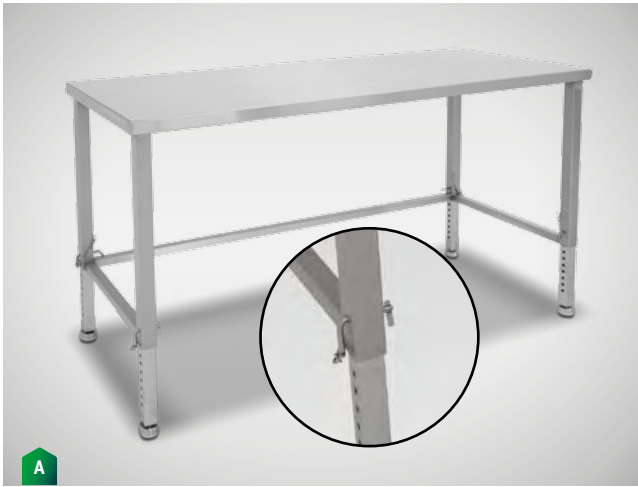

### SHOWN OPTIONS

A Table leg height adjustment "Easy"	Article no. 21.00.08.86
B Underneath box drawer (W: 400 x D: 500 x H: 150 mm)	Article no. 21.00.08.85

C Mobile, 2 rigid and 2 swivel casters with locking mechanism	Article no. 99.90.01.50
Mobile, 4 swivel casters with locking mechanism	Article no. 99.90.01.51
D Stable stainless steel supporting feet	Article no. 99.87.01.48

## Our stainless steel work cabinets



Washing and utility cabinet combination with wall-mounted cabinet



Hygienic version H1



Hygienic version H2



Hygienic version H3

### HYGIENIC VERSION (H1 / H2 / H3) ACCORDING TO DIN 18865-9

For commercial kitchens (dispensing systems) or cleanrooms, we also supply cabinet interiors in hygiene versions H1 to H3.

The DIN 18865-9 standard specifies the requirements that stainless steel furniture must meet in order to be allowed to equip a clean room, for example.

**TYPE AS**

**Work cabinets**



**Type AS-OZ** Open on the operator side, 1 intermediate shelf



**Type AS-FZ** Hinged doors on the operator side, 1 intermediate shelf

**TYPE AS-OZ**

Height: 850 mm, without doors

WIDTH in mm	ARTICLE NO. Depth: 600 mm	ARTICLE NO. Depth: 700 mm	ARTICLE NO. Depth: 800 mm
1000	22.00.05.60	22.00.05.73	22.00.05.86
1100	22.00.05.61	22.00.05.74	22.00.05.87
1200	22.00.05.62	22.00.05.75	22.00.05.88
1300	22.00.05.63	22.00.05.76	22.00.05.89
1400	22.00.05.64	22.00.05.77	22.00.05.90
1500	22.00.05.65	22.00.05.78	22.00.05.91
1600	22.00.05.66	22.00.05.79	22.00.05.92
1700	22.00.05.67	22.00.05.80	22.00.05.93
1800	22.00.05.68	22.00.05.81	22.00.05.94
1900	22.00.05.69	22.00.05.82	22.00.05.95
2000	22.00.05.70	22.00.05.83	22.00.05.96
2100	22.00.05.71	22.00.05.84	22.00.05.97
2200	22.00.05.72	22.00.05.85	22.00.05.98

**TYPE AS-FZ**

Height: 850 mm, hinged doors

WIDTH in mm	ARTICLE NO. Depth: 600 mm	ARTICLE NO. Depth: 700 mm	ARTICLE NO. Depth: 800 mm
1000	22.00.05.99	22.00.06.12	22.00.06.25
1100	22.00.06.00	22.00.06.13	22.00.06.26
1200	22.00.06.01	22.00.06.14	22.00.06.27
1300	22.00.06.02	22.00.06.15	22.00.06.28
1400	22.00.06.03	22.00.06.16	22.00.06.29
1500	22.00.06.04	22.00.06.17	22.00.06.30
1600	22.00.06.05	22.00.06.18	22.00.06.31
1700	22.00.06.06	22.00.06.19	22.00.06.32
1800	22.00.06.07	22.00.06.20	22.00.06.33
1900	22.00.06.08	22.00.06.21	22.00.06.34
2000	22.00.06.09	22.00.06.22	22.00.06.35
2100	22.00.06.10	22.00.06.23	22.00.06.36
2200	22.00.06.11	22.00.06.24	22.00.06.37





**Type AS-SZ** Sliding doors on the operator side, 1 intermediate shelf

We produce all cabinets also individually as desired by the customer!

**WORK CABINETS TYPE AS**

- Cabinet body closed on three sides, material thickness 1.0 mm
- Work top in 1.5 mm material thickness
- Work top chamfered on 3 sides, rear 40 mm flanged [gallery], alternatively: smoothly chamfered on all sides
- Work top underneath reinforced with hat profile
- Cabinet interior with 1 height-adjustable [50 mm grid] Storage shelf in 1.0 mm material thickness
- Lower structure with stable square pipe frame construction [40 x 40 x 1.5 mm]
- 4 height-adjustable plastic screw feet [+/- 30 mm]
- Standard ground clearance: 150 mm

**LOWER STRUCTURE**

- Open on the operator side, without doors [Type AS-OZ]
- With double-walled sliding doors on the operator side [Type AS-SZ], Material thickness 1.0 mm
- With double-walled hinged doors on the operator side [Type AS-FZ], Material thickness 1.0 mm

**OPTIONS**

Doors lockable by means of profile cylinder lock	on request
Corner work cabinets, open on the operator side or with hinged door	on request
Mobile version [2 rigid casters and 2 swivel casters with locking mechanism], Ø125 mm	Article no. 99.90.01.50
Retrofitting set "Expander" [2 rigid casters and 2 swivel casters with locking mechanism], for profile 40 x 40 x 1.5 mm	Article no. 99.90.01.99
Drawer block left/right	see page 260

**TYPE AS-SZ**

Height: 850 mm, sliding doors

WIDTH in mm	ARTICLE NO. Depth: 600 mm	ARTICLE NO. Depth: 700 mm	ARTICLE NO. Depth: 800 mm
1000	22.00.06.38	22.00.06.51	22.00.06.64
1100	22.00.06.39	22.00.06.52	22.00.06.65
1200	22.00.06.40	22.00.06.53	22.00.06.66
1300	22.00.06.41	22.00.06.54	22.00.06.67
1400	22.00.06.42	22.00.06.55	22.00.06.68
1500	22.00.06.43	22.00.06.56	22.00.06.69
1600	22.00.06.44	22.00.06.57	22.00.06.70
1700	22.00.06.45	22.00.06.58	22.00.06.71
1800	22.00.06.46	22.00.06.59	22.00.06.72
1900	22.00.06.47	22.00.06.60	22.00.06.73
2000	22.00.06.48	22.00.06.61	22.00.06.74
2100	22.00.06.49	22.00.06.62	22.00.06.75
2200	22.00.06.50	22.00.06.63	22.00.06.76

**MATERIAL**

- Stainless steel furniture made of chrome-nickel steel 18/10 material No. 1.4301
- The externally visible stainless steel sheet surfaces have a 320 grit polished finish.
- The externally visible stainless steel profile surfaces, such as the table legs, have a uniform brushed finish.





**TYPE AS HIGHLINE**

**Work cabinets**



**Type AS/H** Hinged doors on the operator side



**Type SZ/H** Sliding doors on the operator side

**TYPE AS-FZ/H**

Height: 850 mm, hinged doors

WIDTH in mm	ARTICLE NO. Depth: 600 mm	ARTICLE NO. Depth: 700 mm	ARTICLE NO. Depth: 800 mm
1000	22.00.06.77	22.00.06.90	22.00.07.03
1100	22.00.06.78	22.00.06.91	22.00.07.04
1200	22.00.06.79	22.00.06.92	22.00.07.05
1300	22.00.06.80	22.00.06.93	22.00.07.06
1400	22.00.06.81	22.00.06.94	22.00.07.07
1500	22.00.06.82	22.00.06.95	22.00.07.08
1600	22.00.06.83	22.00.06.96	22.00.07.09
1700	22.00.06.84	22.00.06.97	22.00.07.10
1800	22.00.06.85	22.00.06.98	22.00.07.11
1900	22.00.06.86	22.00.06.99	22.00.07.12
2000	22.00.06.87	22.00.07.00	22.00.07.13
2100	22.00.06.88	22.00.07.01	22.00.07.14
2200	22.00.06.89	22.00.07.02	22.00.07.15

**TYPE AS-SZ/H**

Height: 850 mm, sliding doors

WIDTH in mm	ARTICLE NO. Depth: 600 mm	ARTICLE NO. Depth: 700 mm	ARTICLE NO. Depth: 800 mm
1000	22.00.07.16	22.00.07.29	22.00.07.42
1100	22.00.07.17	22.00.07.30	22.00.07.43
1200	22.00.07.18	22.00.07.31	22.00.07.44
1300	22.00.07.19	22.00.07.32	22.00.07.45
1400	22.00.07.20	22.00.07.33	22.00.07.46
1500	22.00.07.21	22.00.07.34	22.00.07.47
1600	22.00.07.22	22.00.07.35	22.00.07.48
1700	22.00.07.23	22.00.07.36	22.00.07.49
1800	22.00.07.24	22.00.07.37	22.00.07.50
1900	22.00.07.25	22.00.07.38	22.00.07.51
2000	22.00.07.26	22.00.07.39	22.00.07.52
2100	22.00.07.27	22.00.07.40	22.00.07.53
2200	22.00.07.28	22.00.07.41	22.00.07.54

Particularly suitable for use  
in pharmacy, laboratories,  
medicine and clean rooms

**WORK CABINETS TYPE AS HIGHLINE**

- Doors with polycarbonate panel as well as rubber seal  
Advantage: Visible compliance with rules
- Cabinet body closed on three sides, material thickness 1.0 mm
- Work top in 1.5 mm material thickness
- Work top chamfered on 3 sides, rear 40 mm flanged (gallery),  
alternatively: smoothly chamfered on all sides
- Work top underneath reinforced with hat profile
- Cabinet interior with 1 height-adjustable (50 mm grid)  
Storage shelf in 1.0 mm material thickness
- Lower structure with stable square pipe frame construction  
(40 x 40 x 1.5 mm)
- 4 height-adjustable plastic screw feet (+/- 30 mm)
- Standard ground clearance: 150 mm

**LOWER STRUCTURE**

- With double-walled sliding doors on the operator side  
(Type AS-SZ), Material thickness 1.0 mm
- With double-walled hinged doors on the operator side  
(Type AS-FZ), Material thickness 1.0 mm

**MATERIAL**

- Stainless steel furniture made of chrome-nickel steel 18/10  
material No. 1.4301
- The externally visible stainless steel sheet surfaces have  
a 320 grit polished finish.
- The externally visible stainless steel profile surfaces, such as  
the table legs, have a uniform brushed finish.

**OPTIONS**

Doors lockable by means of profile cylinder lock	on request
Corner work cabinets, open on the operator side or with hinged door	on request
Mobile version (2 rigid casters and 2 swivel casters with locking mechanism), Ø125 mm	Article no. 99.90.01.50
Retrofitting set "Expander" (2 rigid casters and 2 swivel casters with locking mechanism), for profile 40 x 40 x 1.5 mm	Article no. 99.90.01.99

We produce all cabinets also individually  
as desired by the customer!

**TYPE AS-SL/-SR**

**Work cabinets** Drawer unit left or right



Type AS-OZ-SL Drawer unit left, without doors



Type AS-FZ-SL Drawer unit left, with hinged doors



Type AS-SZ-SL Drawer unit left, with sliding doors

	22.00.11.86			TYPE AS-FZ-SL Height: 850 mm, hinged doors			TYPE AS-SZ-SL Height: 850 mm, sliding doors		
WIDTH in mm	ARTICLE NO. Depth: 600 mm	ARTICLE NO. Depth: 700 mm	ARTICLE NO. Depth: 800 mm	ARTICLE NO. Depth: 600 mm	ARTICLE NO. Depth: 700 mm	ARTICLE NO. Depth: 800 mm	ARTICLE NO. Depth: 600 mm	ARTICLE NO. Depth: 700 mm	ARTICLE NO. Depth: 800 mm
1000	22.00.09.50	22.00.09.63	22.00.09.76	22.00.11.50	22.00.11.63	22.00.11.76	---	---	---
1100	22.00.09.51	22.00.09.64	22.00.09.77	22.00.11.51	22.00.11.64	22.00.11.77	---	---	---
1200	22.00.09.52	22.00.09.65	22.00.09.78	22.00.11.52	22.00.11.65	22.00.11.78	---	---	---
1300	22.00.09.53	22.00.09.66	22.00.09.79	22.00.11.53	22.00.11.66	22.00.11.79	---	---	---
1400	22.00.09.54	22.00.09.67	22.00.09.80	22.00.11.54	22.00.11.67	22.00.11.80	---	---	---
1500	22.00.09.55	22.00.09.68	22.00.09.81	22.00.11.55	22.00.11.68	22.00.11.81	---	---	---
1600	22.00.09.56	22.00.09.69	22.00.09.82	22.00.11.56	22.00.11.69	22.00.11.82	22.00.11.95	22.00.12.08	22.00.12.21
1700	22.00.09.57	22.00.09.70	22.00.09.83	22.00.11.57	22.00.11.70	22.00.11.83	22.00.11.96	22.00.12.09	22.00.12.22
1800	22.00.09.58	22.00.09.71	22.00.09.84	22.00.11.58	22.00.11.71	22.00.11.84	22.00.11.97	22.00.12.10	22.00.12.23
1900	22.00.09.59	22.00.09.72	22.00.09.85	22.00.11.59	22.00.11.72	22.00.11.85	22.00.11.98	22.00.12.11	22.00.12.24
2000	22.00.09.60	22.00.09.73	22.00.09.86	22.00.11.60	22.00.11.73	22.00.11.86	22.00.11.99	22.00.12.12	22.00.12.25
2100	22.00.09.61	22.00.09.74	22.00.09.87	22.00.11.61	22.00.11.74	22.00.11.87	22.00.12.00	22.00.12.13	22.00.12.26
2200	22.00.09.62	22.00.09.75	22.00.09.88	22.00.11.62	22.00.11.75	22.00.11.88	22.00.12.01	22.00.12.14	22.00.12.27

**WORK CABINET TYPE AS-SL/-SR**

- Drawer block, with 3 drawers on the left or right side, W: 400 x H: 200 mm
- Cabinet body closed on three sides, material thickness 1.0 mm
- Work top in 1.5 mm material thickness
- Work top chamfered on 3 sides, rear 40 mm flanged (gallery), alternatively: smoothly chamfered on all sides
- Work top underneath reinforced with hat profile
- Cabinet interior with 1 height-adjustable (50 mm grid) Storage shelf in 1.0 mm material thickness
- Lower structure with stable square pipe frame construction (40 x 40 x 1.5 mm)
- 4 or 6 height-adjustable plastic screw feet (+/- 30 mm)
- From 2,500 mm length with 6 supporting feet
- Standard ground clearance: 150 mm

**LOWER STRUCTURE**

- Open on the operator side, without doors (Type AS-OZ)
- With double-walled hinged doors on the operator side (Type AS-FZ), Material thickness 1.0 mm
- With double-walled sliding doors on the operator side (Type AS-SZ), Material thickness 1.0 mm

**MATERIAL**

- Stainless steel furniture made of chrome-nickel steel 18/10 material No. 1.4301
- The externally visible stainless steel sheet surfaces have a 320 grit polished finish.
- The externally visible stainless steel profile surfaces, such as the table legs, have a uniform brushed finish.



**Type AS-OZ-SR** Drawer unit right, without doors



**Type AS-FZ-SR** Drawer unit right, with hinged doors



**Type AS-SZ-SR** Drawer unit right, with sliding doors

WIDTH in mm	TYPE AS-OZ-SR Height: 850 mm, without doors			TYPE AS-FZ-SR Height: 850 mm, hinged doors			TYPE AS-SZ-SR Height: 850 mm, sliding doors		
	ARTICLE NO. Depth: 600 mm	ARTICLE NO. Depth: 700 mm	ARTICLE NO. Depth: 800 mm	ARTICLE NO. Depth: 600 mm	ARTICLE NO. Depth: 700 mm	ARTICLE NO. Depth: 800 mm	ARTICLE NO. Depth: 600 mm	ARTICLE NO. Depth: 700 mm	ARTICLE NO. Depth: 800 mm
1000	22.00.13.06	22.00.13.19	22.00.13.32	22.00.13.45	22.00.13.58	22.00.13.71	---	---	---
1100	22.00.13.07	22.00.13.20	22.00.13.33	22.00.13.46	22.00.13.59	22.00.13.72	---	---	---
1200	22.00.13.08	22.00.13.21	22.00.13.34	22.00.13.47	22.00.13.60	22.00.13.73	---	---	---
1300	22.00.13.09	22.00.13.22	22.00.13.35	22.00.13.48	22.00.13.61	22.00.13.74	---	---	---
1400	22.00.13.10	22.00.13.23	22.00.13.36	22.00.13.49	22.00.13.62	22.00.13.75	---	---	---
1500	22.00.13.11	22.00.13.24	22.00.13.37	22.00.13.50	22.00.13.63	22.00.13.76	---	---	---
1600	22.00.13.12	22.00.13.25	22.00.13.38	22.00.13.51	22.00.13.64	22.00.13.77	22.00.13.90	22.00.14.03	22.00.14.16
1700	22.00.13.13	22.00.13.26	22.00.13.39	22.00.13.52	22.00.13.65	22.00.13.78	22.00.13.91	22.00.14.04	22.00.14.17
1800	22.00.13.14	22.00.13.27	22.00.13.40	22.00.13.53	22.00.13.66	22.00.13.79	22.00.13.92	22.00.14.05	22.00.14.18
1900	22.00.13.15	22.00.13.28	22.00.13.41	22.00.13.54	22.00.13.67	22.00.13.80	22.00.13.93	22.00.14.06	22.00.14.19
2000	22.00.13.16	22.00.13.29	22.00.13.42	22.00.13.55	22.00.13.68	22.00.13.81	22.00.13.94	22.00.14.07	22.00.14.20
2100	22.00.13.17	22.00.13.30	22.00.13.43	22.00.13.56	22.00.13.69	22.00.13.82	22.00.13.95	22.00.14.08	22.00.14.21
2200	22.00.13.18	22.00.13.31	22.00.13.44	22.00.13.57	22.00.13.70	22.00.13.83	22.00.13.96	22.00.14.09	22.00.14.22

**OPTIONS**

Doors lockable by means of profile cylinder lock	on request
Corner work cabinets, open on the operator side or with hinged door	on request
Mobile version [2 rigid casters and 2 swivel casters with locking mechanism], Ø125 mm	Article no. 99.90.01.50
Mobile version [6 swivel casters, 2 of which are locking mechanism], Ø 125 mm	Article no. 99.90.01.52
Retrofitting set "Expander" [2 rigid casters and 2 swivel casters with locking mechanism], for profile 40 x 40 x 1.5 mm	Article no. 99.90.01.99
Lockable drawer	on request
Box drawers with full pull-out	on request

We produce all cabinets also individually as desired by the customer!

**TYPE AS-SL/-SR HIGHLINE**

**Work cabinets**



**Type AS-FZ-SL/H** Drawer unit left, with hinged doors on the operator side



**Type AS-SZ-SL/H** Drawer unit left, with sliding doors on the operator side

**TYPE AS-FZ-SL/H**

Height: 850 mm, hinged doors

WIDTH in mm	ARTICLE NO. Depth: 600 mm	ARTICLE NO. Depth: 700 mm	ARTICLE NO. Depth: 800 mm
1000	22.00.12.28	22.00.12.41	22.00.12.54
1100	22.00.12.29	22.00.12.42	22.00.12.55
1200	22.00.12.30	22.00.12.43	22.00.12.56
1300	22.00.12.31	22.00.12.44	22.00.12.57
1400	22.00.12.32	22.00.12.45	22.00.12.58
1500	22.00.12.33	22.00.12.46	22.00.12.59
1600	22.00.12.34	22.00.12.47	22.00.12.60
1700	22.00.12.35	22.00.12.48	22.00.12.61
1800	22.00.12.36	22.00.12.49	22.00.12.62
1900	22.00.12.37	22.00.12.50	22.00.12.63
2000	22.00.12.38	22.00.12.51	22.00.12.64
2100	22.00.12.39	22.00.12.52	22.00.12.65
2200	22.00.12.40	22.00.12.53	22.00.12.66

**TYPE AS-SZ-SL/H**

Height: 850 mm, sliding doors

WIDTH in mm	ARTICLE NO. Depth: 600 mm	ARTICLE NO. Depth: 700 mm	ARTICLE NO. Depth: 800 mm
1000	---	---	---
1100	---	---	---
1200	---	---	---
1300	---	---	---
1400	---	---	---
1500	---	---	---
1600	22.00.12.73	22.00.12.86	22.00.12.99
1700	22.00.12.74	22.00.12.87	22.00.13.00
1800	22.00.12.75	22.00.12.88	22.00.13.01
1900	22.00.12.76	22.00.12.89	22.00.13.02
2000	22.00.12.77	22.00.12.90	22.00.13.03
2100	22.00.12.78	22.00.12.91	22.00.13.04
2200	22.00.12.79	22.00.12.92	22.00.13.05

**WORK CABINET TYPE AS-SL/-SR HIGHLINE**

- Drawer block, with 3 drawers on the left or right side, W: 400 x H: 200 mm
- Cabinet body closed on three sides, material thickness 1.0 mm
- Doors with polycarbonate panel as well as rubber seal Advantage: Visible compliance with rules
- Work top in 1.5 mm material thickness
- Work top chamfered on 3 sides, rear 40 mm flanged [gallery], alternatively: smoothly chamfered on all sides
- Work top underneath reinforced with hat profile
- Cabinet interior with 1 height-adjustable [50 mm grid] Storage shelf in 1.0 mm material thickness

- Lower structure with stable square pipe frame construction [40 x 40 x 1.5 mm]
- 6 height-adjustable plastic screw feet [+/- 30 mm]
- Standard ground clearance: 150 mm

**LOWER STRUCTURE**

- With double-walled hinged doors on the operator side [Type AS-FZ], Material thickness 1.0 mm
- With double-walled sliding doors on the operator side [Type AS-SZ], Material thickness 1.0 mm



Type AS-FZ-SR/H Drawer unit right, hinged doors on the operator side



Type AS-SZ-SR/H Drawer unit right, sliding doors on the operator side

**TYPE AS-FZ-SR/H**

Height: 850 mm, hinged doors

WIDTH in mm	ARTICLE NO. Depth: 600 mm	ARTICLE NO. Depth: 700 mm	ARTICLE NO. Depth: 800 mm
1000	22.00.14.23	22.00.14.36	22.00.14.49
1100	22.00.14.24	22.00.14.37	22.00.14.50
1200	22.00.14.25	22.00.14.38	22.00.14.51
1300	22.00.14.26	22.00.14.39	22.00.14.52
1400	22.00.14.27	22.00.14.40	22.00.14.53
1500	22.00.14.28	22.00.14.41	22.00.14.54
1600	22.00.14.29	22.00.14.42	22.00.14.55
1700	22.00.14.30	22.00.14.43	22.00.14.56
1800	22.00.14.31	22.00.14.44	22.00.14.57
1900	22.00.14.32	22.00.14.45	22.00.14.58
2000	22.00.14.33	22.00.14.46	22.00.14.59
2100	22.00.14.34	22.00.14.47	22.00.14.60
2200	22.00.14.35	22.00.14.48	22.00.14.61

**TYPE AS-SZ-SR/H**

Height: 850 mm, sliding doors

WIDTH in mm	ARTICLE NO. Depth: 600 mm	ARTICLE NO. Depth: 700 mm	ARTICLE NO. Depth: 800 mm
1000	---	---	---
1100	---	---	---
1200	---	---	---
1300	---	---	---
1400	---	---	---
1500	---	---	---
1600	22.00.14.68	22.00.14.81	22.00.14.94
1700	22.00.14.69	22.00.14.82	22.00.14.95
1800	22.00.14.70	22.00.14.83	22.00.14.96
1900	22.00.14.71	22.00.14.84	22.00.14.97
2000	22.00.14.72	22.00.14.85	22.00.14.98
2100	22.00.14.73	22.00.14.86	22.00.14.99
2200	22.00.14.74	22.00.14.87	22.00.15.00

**MATERIAL**

- Stainless steel furniture made of chrome-nickel steel 18/10 material No. 1.4301
- The externally visible stainless steel sheet surfaces have a 320 grit polished finish.
- The externally visible stainless steel profile surfaces, such as the table legs, have a uniform brushed finish.

Particularly suitable for use in pharmacy, laboratories, medicine and clean rooms

**OPTIONS**

Doors lockable by means of profile cylinder lock	on request
Corner work cabinets, open on the operator side or with hinged door	on request
Mobile version [2 rigid casters and 2 swivel casters with locking mechanism], Ø125 mm	Article no. 99.90.01.50
Mobile version [6 swivel casters, 2 of which are locking mechanism], Ø 125 mm	Article no. 99.90.01.52
Retrofitting set "Expander" [2 rigid casters and 2 swivel casters with locking mechanism], for profile 40 x 40 x 1.5 mm	Article no. 99.90.01.99
Lockable drawer	on request
Box drawers with full pull-out	on request

**TYPE AS-K**

**Work cabinets**



**Type AS-KO** Open on the operator side, with box drawers



**Type AS-KF** Hinged doors on the operator side, with box drawers

**TYPE AS-KO**

Height: 850 mm, without doors

WIDTH in mm	ARTICLE NO. Depth: 600 mm	ARTICLE NO. Depth: 700 mm	ARTICLE NO. Depth: 800 mm
1000	22.00.07.55	22.00.07.68	22.00.07.81
1100	22.00.07.56	22.00.07.69	22.00.07.82
1200	22.00.07.57	22.00.07.70	22.00.07.83
1300	22.00.07.58	22.00.07.71	22.00.07.84
1400	22.00.07.59	22.00.07.72	22.00.07.85
1500	22.00.07.60	22.00.07.73	22.00.07.86
1600	22.00.07.61	22.00.07.74	22.00.07.87
1700	22.00.07.62	22.00.07.75	22.00.07.88
1800	22.00.07.63	22.00.07.76	22.00.07.89
1900	22.00.07.64	22.00.07.77	22.00.07.90
2000	22.00.07.65	22.00.07.78	22.00.07.91
2100	22.00.07.66	22.00.07.79	22.00.07.92
2200	22.00.07.67	22.00.07.80	22.00.07.93

**TYPE AS-KF**

Height: 850 mm, hinged doors

WIDTH in mm	ARTICLE NO. Depth: 600 mm	ARTICLE NO. Depth: 700 mm	ARTICLE NO. Depth: 800 mm
1000	22.00.07.94	22.00.08.07	22.00.08.20
1100	22.00.07.95	22.00.08.08	22.00.08.21
1200	22.00.07.96	22.00.08.09	22.00.08.22
1300	22.00.07.97	22.00.08.10	22.00.08.23
1400	22.00.07.98	22.00.08.11	22.00.08.24
1500	22.00.07.99	22.00.08.12	22.00.08.25
1600	22.00.08.00	22.00.08.13	22.00.08.26
1700	22.00.08.01	22.00.08.14	22.00.08.27
1800	22.00.08.02	22.00.08.15	22.00.08.28
1900	22.00.08.03	22.00.08.16	22.00.08.29
2000	22.00.08.04	22.00.08.17	22.00.08.30
2100	22.00.08.05	22.00.08.18	22.00.08.31
2200	22.00.08.06	22.00.08.19	22.00.08.32





**Type AS-KS** Sliding doors on the operator side, with box drawers

We produce all cabinets also individually as desired by the customer!

**WORK CABINET TYPE AS-K**

- Drawers with partial pull-out the work top, H: 150 mm [quantity depending on length]
- Cabinet body closed on three sides, material thickness 1.0 mm
- Work top in 1.5 mm material thickness
- Work top chamfered on 3 sides, rear 40 mm flanged [gallery], alternatively: smoothly chamfered on all sides
- Work top underneath reinforced with hat profile
- Cabinet interior with 1 height-adjustable (50 mm) shelf in 1.0 mm material thickness
- Lower structure with stable square pipe frame construction (40 x 40 x 1.5 mm)
- 4 height-adjustable plastic screw feet (+/- 30 mm)
- Standard ground clearance: 150 mm

**TYPE AS-KS**

Height: 850 mm, sliding doors

WIDTH in mm	ARTICLE NO. Depth: 600 mm	ARTICLE NO. Depth: 700 mm	ARTICLE NO. Depth: 800 mm
1000	22.00.08.33	22.00.08.46	22.00.08.59
1100	22.00.08.34	22.00.08.47	22.00.08.60
1200	22.00.08.35	22.00.08.48	22.00.08.61
1300	22.00.08.36	22.00.08.49	22.00.08.62
1400	22.00.08.37	22.00.08.50	22.00.08.63
1500	22.00.08.38	22.00.08.51	22.00.08.64
1600	22.00.08.39	22.00.08.52	22.00.08.65
1700	22.00.08.40	22.00.08.53	22.00.08.66
1800	22.00.08.41	22.00.08.54	22.00.08.67
1900	22.00.08.42	22.00.08.55	22.00.08.68
2000	22.00.08.43	22.00.08.56	22.00.08.69
2100	22.00.08.44	22.00.08.57	22.00.08.70
2200	22.00.08.45	22.00.08.58	22.00.08.71

**DRAWER QUANTITY TYPE AS-K (DRAWER WIDTH: 400 MM)**

- from length 500 mm - 1 drawer
- from length 950 mm - 2 drawers
- from length 1,400 mm - 3 drawers
- from length 1,850 mm - 4 drawers

**OPTIONS**

Doors lockable by means of profile cylinder lock	on request
Corner work cabinets, open on the operator side or with hinged door	on request
Mobile version (2 rigid casters and 2 swivel casters with locking mechanism), Ø125 mm	Article no. 99.90.01.50
Retrofitting set "Expander" (2 rigid casters and 2 swivel casters with locking mechanism), for profile 40 x 40 x 1.5 mm	Article no. 99.90.01.99
Lockable drawer	on request
Box drawers with full pull-out	on request

**MATERIAL**

- Stainless steel furniture made of chrome-nickel steel 18/10 material No. 1.4301
- The externally visible stainless steel sheet surfaces have a 320 grit polished finish.
- The externally visible stainless steel profile surfaces, such as the table legs, have a uniform brushed finish.

**TYPE AS-K HIGHLINE**

**Work cabinets**



**Type AS-KF/H** Hinged doors on the operator side, with box drawers



**Type AS-KS/H** Sliding doors on the operator side, with box drawers

**TYPE AS-KF/H**

Height: 850 mm, hinged doors

WIDTH in mm	ARTICLE NO. Depth: 600 mm	ARTICLE NO. Depth: 700 mm	ARTICLE NO. Depth: 800 mm
1000	22.00.08.72	22.00.08.85	22.00.08.98
1100	22.00.08.73	22.00.08.86	22.00.08.99
1200	22.00.08.74	22.00.08.87	22.00.09.00
1300	22.00.08.75	22.00.08.88	22.00.09.01
1400	22.00.08.76	22.00.08.89	22.00.09.02
1500	22.00.08.77	22.00.08.90	22.00.09.03
1600	22.00.08.78	22.00.08.91	22.00.09.04
1700	22.00.08.79	22.00.08.92	22.00.09.05
1800	22.00.08.80	22.00.08.93	22.00.09.06
1900	22.00.08.81	22.00.08.94	22.00.09.07
2000	22.00.08.82	22.00.08.95	22.00.09.08
2100	22.00.08.83	22.00.08.96	22.00.09.09
2200	22.00.08.84	22.00.08.97	22.00.09.10

**TYPE AS-KS/H**

Height: 850 mm, sliding doors

WIDTH in mm	ARTICLE NO. Depth: 600 mm	ARTICLE NO. Depth: 700 mm	ARTICLE NO. Depth: 800 mm
1000	22.00.09.11	22.00.09.24	22.00.09.37
1100	22.00.09.12	22.00.09.25	22.00.09.38
1200	22.00.09.13	22.00.09.26	22.00.09.39
1300	22.00.09.14	22.00.09.27	22.00.09.40
1400	22.00.09.15	22.00.09.28	22.00.09.41
1500	22.00.09.16	22.00.09.29	22.00.09.42
1600	22.00.09.17	22.00.09.30	22.00.09.43
1700	22.00.09.18	22.00.09.31	22.00.09.44
1800	22.00.09.19	22.00.09.32	22.00.09.45
1900	22.00.09.20	22.00.09.33	22.00.09.46
2000	22.00.09.21	22.00.09.34	22.00.09.47
2100	22.00.09.22	22.00.09.35	22.00.09.48
2200	22.00.09.23	22.00.09.36	22.00.09.49

Particularly suitable for use  
in pharmacy, laboratories,  
medicine and clean rooms

**WORK CABINET TYPE AS-K**

- Drawers with partial pull-out below the work top, H: 150 mm [quantity depending on length]
- Cabinet body closed on three sides, material thickness 1.0 mm
- Work top in 1.5 mm material thickness
- Work top chamfered on 3 sides, rear 40 mm flanged [gallery], alternatively: smoothly chamfered on all sides
- Work top underneath reinforced with hat profile
- Cabinet interior with 1 height-adjustable [50 mm grid] Storage shelf in 1.0 mm material thickness
- Lower structure with stable square pipe frame construction [40 x 40 x 1.5 mm]
- 4 height-adjustable plastic screw feet [+/- 30 mm]
- Standard ground clearance: 150 mm

**DRAWER QUANTITY TYPE AS-K [DRAWER WIDTH: 400 MM]**

- from length 500 mm - 1 drawer
- from length 950 mm - 2 drawers
- from length 1,400 mm - 3 drawers
- from length 1,850 mm - 4 drawers

**MATERIAL**

- Stainless steel furniture made of chrome-nickel steel 18/10 material No. 1.4301
- The externally visible stainless steel sheet surfaces have a 320 grit polished finish.
- The externally visible stainless steel profile surfaces, such as the table legs, have a uniform brushed finish.

**OPTIONS**

Doors lockable by means of profile cylinder lock	on request
Corner work cabinets, open on the operator side or with hinged door	on request
Mobile version [2 rigid casters and 2 swivel casters with locking mechanism], Ø125 mm	Article no. 99.90.01.50
Retrofitting set "Expander" [2 rigid casters and 2 swivel casters with locking mechanism], for profile 40 x 40 x 1.5 mm	Article no. 99.90.01.99
Lockable drawer	on request
Box drawers with full pull-out	on request

We produce all cabinets also individually  
as desired by the customer!

**TYPE SCS**

**Drawer cabinets**

STAINLESS STEEL 1.4301



Type SCS-S 8



Type SCS-F 6

**DRAWER CABINETS TYPE SCS**

- Cabinet body closed on three sides, material thickness 1.0 mm
- Work top underneath reinforced with hat profile, Material thickness 1.5 mm
- Work top chamfered on 3 sides, rear 40 mm flanged (gallery), alternatively: smoothly chamfered on all sides
- With 6 or 8 box drawers on the operator side with partial pull-out [2/3]
- Different drawer sizes
- Lower structure with stable square pipe frame construction [40 x 40 x 1.5 mm]
- Floor model: 4 height-adjustable (+/- 30 mm) plastic screw feet [Type SCS-S 8]
- Mobile version: 2 rigid casters and 2 swivel casters with locking mechanism, Ø 125 mm [Type SCS-F 6]
- Standard ground clearance: 150 mm

**VERSIONS**

- 2 different standard drawer cabinets
- Different drawer versions
- Floor model: [Type SCS-S 8]
- Mobile version: [Type SCS-F 6]
- Drawer height: 110 mm [SCS-S 8], 150 mm [SCS-F 6]

TYPE	VERSION	DIMENSIONS	ARTICLE NO.
		W x D x H in mm	
SCS-S 8	8 drawers	1000 x 500 x 1190	99.86.00.00
SCS-F 6	6 drawers	500 x 500 x 1190	99.86.00.01

**OPTIONS**

Drawers, lockable by means of profile cylinder lock	on request
Box drawers with full pull-out	on request
Retrofitting set "Expander" [2 rigid casters and 2 swivel casters with locking mechanism], for profile 40 x 40 x 1.5 mm	Article no. 99.90.01.99

**MATERIAL**

- Stainless steel furniture made of chrome-nickel steel 18/10 material No. 1.4301
- The externally visible stainless steel sheet surfaces have a 320 grit polished finish.
- The externally visible stainless steel profile surfaces, such as the table legs, have a uniform brushed finish.

**TYPE ASL**

# Drawer block

STAINLESS STEEL 1.4301



Type ASL-2



Type ASL-3



Type ASL-4

**TYPE ASL-2**

2 drawers on the operator side in H: 310 mm

**TYPE ASL-2**  
Height: 850 mm

WIDTH in mm	ARTICLE NO. Depth: 600 mm	ARTICLE NO. Depth: 700 mm	ARTICLE NO. Depth: 800 mm
445	21.00.02.70	21.00.02.73	21.00.02.76
655	21.00.02.71	21.00.02.74	21.00.02.77
775	21.00.02.72	21.00.02.75	21.00.02.78

**TYPE ASL-3**

2 drawers on the operator side in H: 160 mm  
1 drawers in H: 310 mm

**TYPE ASL-3**  
Height: 850 mm

WIDTH in mm	ARTICLE NO. Depth: 600 mm	ARTICLE NO. Depth: 700 mm	ARTICLE NO. Depth: 800 mm
445	21.00.02.80	21.00.02.83	21.00.02.86
655	21.00.02.81	21.00.02.84	21.00.02.87
775	21.00.02.82	21.00.02.85	21.00.02.88

**TYPE ASL-4**

4 drawers on the operator side in H: 155 mm

**TYPE ASL-4**  
Height: 850 mm

WIDTH in mm	ARTICLE NO. Depth: 600 mm	ARTICLE NO. Depth: 700 mm	ARTICLE NO. Depth: 800 mm
445	21.00.08.71	21.00.08.74	21.00.08.77
655	21.00.08.72	21.00.08.75	21.00.08.78
775	21.00.08.73	21.00.08.76	21.00.08.79

**DRAWER BLOCK TYPE ASL**

- 3 different standard drawer blocks with box drawers with partial pull-out
- Cabinet body closed on three sides, material thickness 1.0 mm
- Work top in 1.5 mm material thickness
- Work top smoothly chamfered on all sides
- Lower structure with stable square pipe frame construction [40 x 40 x 1.5 mm]
- With 2, 3 or 4 box drawers with partial pull-out [2/3] optionally on the operator side:
  - Type ASL-2: 2 drawers in H: 310 mm
  - Type ASL-3: 2 drawers in H: 160 mm, 1 drawer in H: 310 mm
  - Type ASL-4: 4 drawers in H: 155 mm
- 4 height-adjustable [+/- 30 mm] plastic screw feet
- Standard ground clearance: 150 mm

**OPTIONS**

Drawers, lockable by means of profile cylinder lock	on request
Box drawers with full pull-out	on request
Retrofitting set "Expander" [2 rigid casters and 2 swivel casters with locking mechanism]	Article no. 99.90.01.99

**MATERIAL**

- Stainless steel furniture made of chrome-nickel steel 18/10 material No. 1.4301
- The externally visible stainless steel sheet surfaces have a 320 grit polished finish.
- The externally visible stainless steel profile surfaces, such as the table legs, have a uniform brushed finish.

## Drawer cabinet as desired by the customer

---

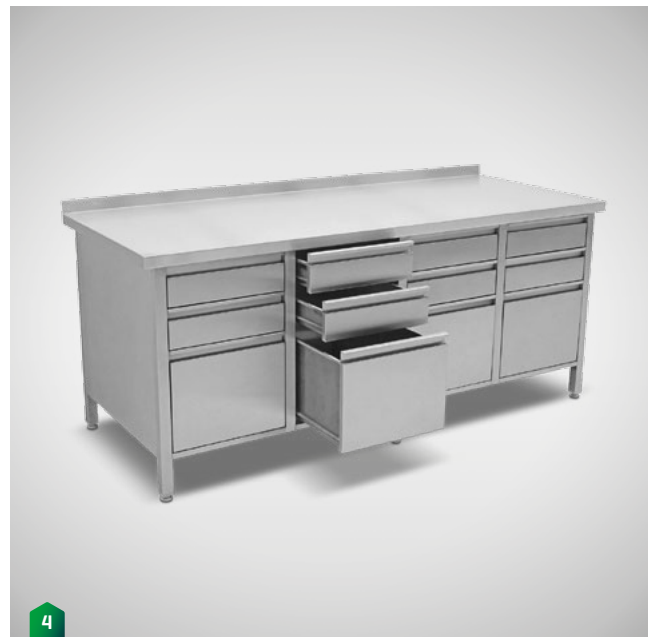

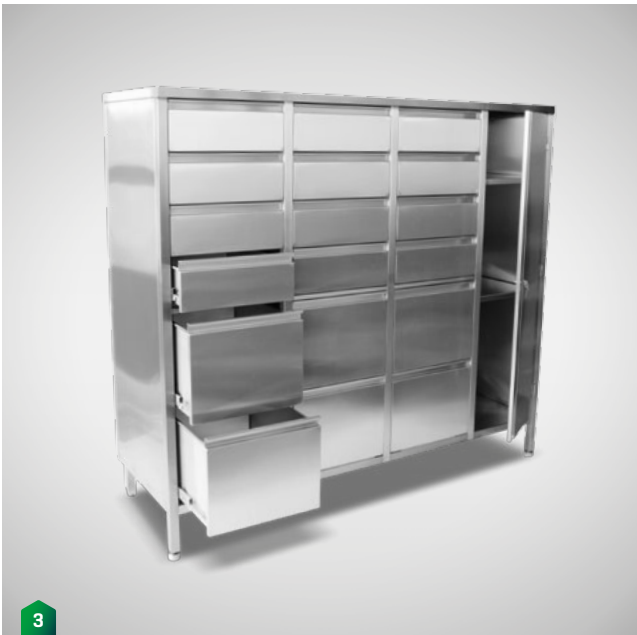

**Here could be  
your solution  
shown!**



**TYPE WS**

**Wall-mounted cabinets**



**Type WS-OZ** Open on the operator side, 1 intermediate shelf, height-adjustable



**Type WS-FZ** Hinged doors on the operator side, 1 intermediate shelf, height-adjustable

**TYPE WS-OZ**

Height: 600 mm, without doors

WIDTH in mm	ARTICLE NO.	
	Depth: 350 mm	Depth: 400 mm
800	22.00.20.00	22.00.20.13
900	22.00.20.01	22.00.20.14
1000	22.00.20.02	22.00.20.15
1100	22.00.20.03	22.00.20.16
1200	22.00.20.04	22.00.20.17
1300	22.00.20.05	22.00.20.18
1400	22.00.20.06	22.00.20.19
1500	22.00.20.07	22.00.20.20
1600	22.00.20.08	22.00.20.21
1700	22.00.20.09	22.00.20.22
1800	22.00.20.10	22.00.20.23
1900	22.00.20.11	22.00.20.24
2000	22.00.20.12	22.00.20.25

Other versions and dimensions on request!

**TYPE WS-FZ**

Height: 600 mm, hinged doors

WIDTH in mm	ARTICLE NO.	
	Depth: 350 mm	Depth: 400 mm
800	22.00.25.00	22.00.25.13
900	22.00.25.01	22.00.25.14
1000	22.00.25.02	22.00.25.15
1100	22.00.25.03	22.00.25.16
1200	22.00.25.04	22.00.25.17
1300	22.00.25.05	22.00.25.18
1400	22.00.25.06	22.00.25.19
1500	22.00.25.07	22.00.25.20
1600	22.00.25.08	22.00.25.21
1700	22.00.25.09	22.00.25.22
1800	22.00.25.10	22.00.25.23
1900	22.00.25.11	22.00.25.24
2000	22.00.25.12	22.00.25.25

Other versions and dimensions on request!



**Type WS-SZ** Sliding doors on the operator side, 1 intermediate shelf, height-adjustable



**Type WS-SZ** with pitched roof

We produce all cabinets also individually as desired by the customer!

**TYPE WS-SZ**

Height: 600 mm, sliding doors

WIDTH in mm	ARTICLE NO. Depth: 350 mm	ARTICLE NO. Depth: 400 mm
800	---	---
900	---	---
1000	22.00.30.02	22.00.30.15
1100	22.00.30.03	22.00.30.16
1200	22.00.30.04	22.00.30.17
1300	22.00.30.05	22.00.30.18
1400	22.00.30.06	22.00.30.19
1500	22.00.30.07	22.00.30.20
1600	22.00.30.08	22.00.30.21
1700	22.00.30.09	22.00.30.22
1800	22.00.30.10	22.00.30.23
1900	22.00.30.11	22.00.30.24
2000	22.00.30.12	22.00.30.25

Other versions and dimensions on request!

**WALL-MOUNTED CABINET TYPE WS**

- Cabinet body closed on three sides
- Version in 1.0 mm material thickness
- Optional on operator side:
  - Open [Type WS-OZ], 2 double-walled hinged doors [Type WS-FZ] or sliding doors [Type WS-SZ]
- Cabinet interior with 1 height-adjustable storage shelf
- Overall height: 600 mm

**OPTIONS**

Doors lockable by means of profile cylinder lock	on request
Corner wall-mounted cabinets, open on the operator side or with hinged door	on request
Pitched roof, 200 mm higher at the back	Article no. 45.00.90.09
Built-in or integrated chutes	on request

**MATERIAL**

- Stainless steel furniture made of chrome-nickel steel 18/10 material No. 1.4301
- The externally visible stainless steel sheet surfaces have a 320 grit polished finish.
- The externally visible stainless steel profile surfaces, such as the table legs, have a uniform brushed finish.

**TYPE WS HIGHLINE**

**Wall-mounted cabinets**



**Type WS-FZ/H** Hinged doors on the operator side, 1 intermediate shelf, height-adjustable



**Type WS-SZ/H** Sliding doors on the operator side, 1 intermediate shelf, height-adjustable

**TYPE WS-FZ/H**

Height: 600 mm, hinged doors

WIDTH in mm	ARTICLE NO.	ARTICLE NO.
	Depth: 350 mm	Depth: 400 mm
800	22.00.35.00	22.00.35.13
900	22.00.35.01	22.00.35.14
1000	22.00.35.02	22.00.35.15
1100	22.00.35.03	22.00.35.16
1200	22.00.35.04	22.00.35.17
1300	22.00.35.05	22.00.35.18
1400	22.00.35.06	22.00.35.19
1500	22.00.35.07	22.00.35.20
1600	22.00.35.08	22.00.35.21
1700	22.00.35.09	22.00.35.22
1800	22.00.35.10	22.00.35.23
1900	22.00.35.11	22.00.35.24
2000	22.00.35.12	22.00.35.25

Other versions and dimensions on request!

**TYPE WS-SZ/H**

Height: 600 mm, sliding doors

WIDTH in mm	ARTICLE NO.	ARTICLE NO.
	Depth: 350 mm	Depth: 400 mm
800	---	---
900	---	---
1000	22.00.40.02	22.00.40.15
1100	22.00.40.03	22.00.40.16
1200	22.00.40.04	22.00.40.17
1300	22.00.40.05	22.00.40.18
1400	22.00.40.06	22.00.40.19
1500	22.00.40.07	22.00.40.20
1600	22.00.40.08	22.00.40.21
1700	22.00.40.09	22.00.40.22
1800	22.00.40.10	22.00.40.23
1900	22.00.40.11	22.00.40.24
2000	22.00.40.12	22.00.40.25

Other versions and dimensions on request!

Particularly suitable for use  
in pharmacy, laboratories,  
medicine and clean rooms

**WALL-MOUNTED CABINETS TYPE WS HIGHLINE**

- Doors with polycarbonate panel as well as rubber seal, Advantage: Visible compliance with rules
- Cabinet body closed on three sides
- Version in 1.0 mm material thickness
- Optional on operator side:  
2 double-walled hinged doors [Type WS-FZ] or sliding doors [Type WS-SZ]
- Cabinet interior with 1 height-adjustable storage shelf
- Overall height: 600 mm

**MATERIAL**

- Stainless steel furniture made of chrome-nickel steel 18/10 material No. 1.4301
- The externally visible stainless steel sheet surfaces have a 320 grit polished finish.
- The externally visible stainless steel profile surfaces, such as the table legs, have a uniform brushed finish.

**OPTIONS**

Doors lockable by means of profile cylinder lock	on request
Corner wall-mounted cabinets, open on the operator side or with hinged door	on request
Pitched roof, 200 mm higher at the back	Article no. 45.00.90.09
Built-in or integrated chutes	on request

We produce all cabinets also  
individually as  
desired by the customer!



**Special solutions**  
Type WS-FZ with chutes and pitched roof

**TYPE WPO**

**Wall-mounted desks**

STAINLESS STEEL 1.4301



**TYPE WPO-1** Storage board [writing storage]



**TYPE WPO-2 MINI** Foldable desk lid



**TYPE WPO-3 INDUSTRY** Foldable desk lid

**TYPE WPO-1**

TYPE	DIMENSIONS W x D x H in mm	ARTICLE NO.
WPO-1	480 x 350 x 130	49.00.00.77

**TYPE WPO-2 MINI**

TYPE	DIMENSIONS W x D x H in mm	ARTICLE NO.
WPO-2 M	300 x 280 x 150/250	18.00.01.38

**TYPE WPO-3 INDUSTRY**

TYPE	DIMENSIONS W x D x H in mm	ARTICLE NO.
WPO-3 I	600 x 500 x 250	49.00.02.61

**TYPE WPO-1**

- Writing surface approx. DIN A3 landscape
- Material thickness 2 mm
- Angle of inclination 15°
- Rear backsplash 30 mm
- Key hole drilling for wall mounting
- Wall-mounted version

**TYPE WPO-2 MINI**

- Material thickness 1.5 mm
- Foldable desk lid
- Stowage shelf below the desk lid
- Writing surface with front pencil trough
- Shelf space on the wall side
- Wall-mounted version

**TYPE WPO-3 INDUSTRY**

- Material thickness 1.5 mm
- Foldable desk lid
- Stowage shelf below the desk lid
- Writing surface with pencil trough
- Shelf space on the wall side
- Wall-mounted version



Practical example

We also manufacture all desks individually as desired by the customer!

**MATERIAL**

- Stainless steel furniture made of chrome-nickel steel 18/10 material No. 1.4301
- The externally visible stainless steel sheet surfaces have a 320 grit polished finish.

**TYPE WPS-I**

## Wall-mounted desk

STAINLESS STEEL 1.4301



- Writing desk with drawer
- Welded stainless steel design
- Key hole drilling for wall mounting
- Shelf space on the wall side
- Desk writing surface with inclination
- Writing surface with front pencil trough
- Box drawer with partial pull-out, Height: 150 mm
- Box drawer lockable with cylinder lock

TYPE	VERSION	DIMENSIONS	ARTICLE NO.
		W x D x H in mm	
WPS-I	Lockable	600 x 500 x 320	49.00.02.10

**TYPE WPS-II**

## Wall-mounted desk

STAINLESS STEEL 1.4301



- Extra storage space:  
lockable drawer and foldable desk lid
- Welded stainless steel design
- Key hole drilling for wall mounting
- Foldable desk lid with writing surface
- Stowage shelf below the desk lid
- Shelf space on the wall side
- Writing surface with front pencil trough
- Box drawer with partial pull-out, Height: 150 mm
- Box drawer lockable with cylinder lock

TYPE	VERSION	DIMENSIONS	ARTICLE NO.
		W x D x H in mm	
WPS-II	lockable, foldable desk lid	600 x 500 x 400	49.00.02.13

**OPTIONS**

Desk lid lockable [only Type WPO]	Article no. 49.00.99.99
Panel bottom made of wire mesh [only Type SPO]	Article no. 99.80.02.75

**TYPE SPO**

**Standing desks**



Type SPO-H with Hygienic-Design strut



Type SPO-B with storage shelf

**TYPE SPO-H**

TYPE	VERSION	DIMENSIONS W x D x H in mm	ARTICLE NO.
SPO-H/S	Stand feet	600 x 500 x 1250	49.00.02.25
SPO-H/F	Mobile	600 x 500 x 1250	49.00.02.26

**TYPE SPO-B**

TYPE	VERSION	DIMENSIONS W x D x H in mm	ARTICLE NO.
SPO-B/S	Stand feet	600 x 500 x 1250	49.00.02.27
SPO-B/F	Mobile	600 x 500 x 1250	49.00.02.28

**TYPE SPO-H**

- Foldable desk lid
- Stowage shelf below the desk lid
- Writing surface with pencil trough
- Shelf space on the wall side
- Material thickness 1.5 mm
- Lower structure open with H-strut
- Ground clearance 150 or 180 mm

**TYPE SPO-B**

- Foldable desk lid
- Stowage shelf below the desk lid
- Writing surface with pencil trough
- Shelf space on the wall side
- Material thickness 1.5 mm
- Lower structure with storage shelf
- Ground clearance 150 or 180 mm



Type SPO-H/F



Type SPO-B/F





Type SPO-R with storage grate

We also manufacture all desks individually as desired by the customer!

**STANDING DESKS TYPE SP**

- Version in 1.5 mm material thickness
- Floor model: 4 height-adjustable plastic screw feet (+/- 30 mm)
- Mobile version: 4 polyamide swivel casters, 2 with locking mechanism, Ø 125 mm
- Standard ground clearance: 150 mm [supporting feet] or 180 mm [on rollers]

**TYPE SPO-R**

TYPE	VERSION	DIMENSIONS W x D x H in mm	ARTICLE NO.
SPO-R/S	Stand feet	600 x 500 x 1250	49.00.02.29
SPO-R/F	Mobile	600 x 500 x 1250	49.00.02.30

**LOWER STRUCTURE**

- H-shape strutted in the Hygienic-Design diamond profile [Type SPO-H]
- 1 intermediate shelf - welded in solidly [Type SPO-B]
- 1 storage grate, across - welded in solidly [Type SPO-R]

**OPTIONS**

Desk lid lockable [Type SPO]	Article no. 49.00.99.99
1 box drawers with partial pull-out [only Type SPO]	Article no. 99.80.02.76
Additional storage shelf [only Type SPO]	Article no. 99.80.02.74
Additional storage grate [only Type SPO]	Article no. 99.80.02.73
Panel bottom made of wire mesh [only Type SPO]	Article no. 99.80.02.75

**TYPE SPO-R**

- Foldable desk lid
- Stowage shelf below the desk lid
- Writing surface with pencil trough
- Shelf space on the wall side
- Material thickness 1.5 mm
- Lower structure with storage grate, across
- Ground clearance 150 or 180 mm



Type SPO-R/F

**MATERIAL**

- Stainless steel furniture made of chrome-nickel steel 18/10 material No. 1.4301
- The externally visible stainless steel sheet surfaces have a 320 grit polished finish.
- The externally visible stainless steel profile surfaces, such as the table legs, have a uniform brushed finish.

**TYPE SPG-E**

**Standing desks**

STAINLESS STEEL 1.4301



Type SPG-E-S



Type SPG-E-F mobile

**TYPE SPG-E**

TYPE	VERSION	DIMENSIONS W x D x H in mm	ARTICLE NO.
SPG-E-S 50/ 40	Stand feet	500 x 400 x 1170	49.00.09.17
SPG-E-F 50/ 40	Mobile	500 x 400 x 1170	49.00.09.53

**OPTIONS**

Highline version for standing desks Type SPG-E Article no. 49.00.19.00  
 (with 1-leaf hinged door, polycarbonate pane and rubber seal)

**STANDING DESKS TYPE SPG-E**

- 1 hinged door with lockable T-handle
- Operator side with hinged door
- Cabinet body closed on three sides, material thickness 1.0 mm
- Writing desk in 1.5 mm material thickness
- Cabinet interior with 2 height-adjustable storage shelves
- 4 height-adjustable plastic screw feet [+/- 30 mm] or 4 polyamide swivel casters, Ø 125 mm [2 with locking mechanism]
- Standard ground clearance: 150 mm

**MATERIAL**

- Stainless steel furniture made of chrome-nickel steel 18/10 material No. 1.4301
- The externally visible stainless steel sheet surfaces have a 320 grit polished finish.
- The externally visible stainless steel profile surfaces, such as the table legs, have a uniform brushed finish.

**TYPE SPG-D**

**Standing desks**

STAINLESS STEEL 1.4301



Type SPG-D-S



Type SPG-D-F mobile

**TYPE SPG-D**

TYPE	VERSION	DIMENSIONS W x D x H in mm	ARTICLE NO.
SPG-D-S 80/ 40	Stand feet	800 x 400 x 1170	49.00.09.15
SPG-D-F 80/ 40	Mobile	800 x 400 x 1170	49.00.09.13

**OPTIONS**

Highline version for standing desks Type SPG-D Article no. 49.00.19.01  
 (with 1-leaf hinged door, polycarbonate pane and rubber seal)

**STANDING DESKS TYPE SPG-D**

- Doors lockable by means of T-handle including profile cylinder lock
- With 2 hinged door on the operator side
- Cabinet body closed on three sides, material thickness 1.0 mm
- Writing desk in 1.5 mm material thickness
- Cabinet interior with 2 height-adjustable storage shelves
- 4 height-adjustable plastic screw feet [+/- 30 mm] or 4 polyamide swivel casters, Ø 125 mm [2 with locking mechanism]
- Standard ground clearance: 150 mm

**MATERIAL**

- Stainless steel furniture made of chrome-nickel steel 18/10 material No. 1.4301
- The externally visible stainless steel sheet surfaces have a 320 grit polished finish.
- The externally visible stainless steel profile surfaces, such as the table legs, have a uniform brushed finish.

We also manufacture all desks individually as desired by the customer!

**TYPE SPG-S/E**

**Standing desk cabinets**

STAINLESS STEEL 1.4301



Type SPG-S/E-S



Type SPG-S/E-F mobile

**TYPE SPG-S/E**

TYPE	VERSION	DIMENSIONS W x D x H in mm	ARTICLE NO.
SPG-S/E-S 50/ 40	Stand feet	500 x 400 x 1170	49.00.09.18
SPG-S/E-F 50/40	Mobile	500 x 400 x 1170	49.00.09.19

**OPTIONS**

Highline version for standing desks Type SPG-E/E Article no. 49.00.19.02 (with 1-leaf hinged door, polycarbonate pane and rubber seal)

**STANDING DESKS TYPE SPG-S/E**

- With hinged door on the operator side and 1 box drawer
- 1 hinged door with lockable T-handle
- 1 box drawer, lockable
- Box drawer with partial pull-out
- Box drawer height: 150 mm, lockable
- Cabinet body closed on three sides, material thickness 1.0 mm
- Writing desk in 1.5 mm material thickness
- Cabinet interior with 1 height-adjustable storage shelf
- 4 height-adjustable plastic screw feet [+/- 30 mm] or 4 polyamide swivel casters, Ø 125 mm [2 with locking mechanism]
- Standard ground clearance: 150 mm

**MATERIAL**

- Stainless steel furniture made of chrome-nickel steel 18/10 material No. 1.4301
- The externally visible stainless steel sheet surfaces have a 320 grit polished finish.
- The externally visible stainless steel profile surfaces, such as the table legs, have a uniform brushed finish.

**TYPE SPG-S/D**

## Standing desk cabinets

STAINLESS STEEL 1.4301



Type SPG-S/D-S



Type SPG-S/D-F mobile

**TYPE SPG-D**

TYPE	VERSION	DIMENSIONS W x D x H in mm	ARTICLE NO.
SPG-S/D-S 80/ 40	Stand feet	800 x 400 x 1170	49.00.09.14
SPG-S/D-F 80/ 40	Mobile	800 x 400 x 1170	49.00.09.16

**OPTIONS**

Highline version for standing desks Type SPG-S/D Article no. 49.00.19.03  
(with 1-leaf hinged door, polycarbonate pane and rubber seal)

**STANDING DESKS TYPE SPG-S/D**

- With hinged door on the operator side and 1 box drawer
- 2 hinged doors with lockable T-handle
- 1 box drawer, lockable
- Box drawer with partial pull-out [only Type SPG-S]
- Box drawer height: 150 mm, lockable
- Cabinet body closed on three sides, material thickness 1.0 mm
- Writing desk in 1.5 mm material thickness
- Cabinet interior with 1 height-adjustable storage shelf
- 4 height-adjustable plastic screw feet [+/- 30 mm] or 4 polyamide swivel casters, Ø 125 mm [2 with locking mechanism]
- Standard ground clearance: 150 mm

**MATERIAL**

- Stainless steel furniture made of chrome-nickel steel 18/10 material No. 1.4301
- The externally visible stainless steel sheet surfaces have a 320 grit polished finish.
- The externally visible stainless steel profile surfaces, such as the table legs, have a uniform brushed finish.

We also manufacture all desks individually as desired by the customer!

**TYPE WSW-6L**

**Workshop trolleys**

STAINLESS STEEL 1.4301



Type WSW-6L



Type WSW-6L/A

- Robust version for workshop use
- Stainless steel work surface with backslash [Type WSW-6L/A] or without backslash [Type WSW-6L]
- Push handle Ø 20mm [crossbar] on the face
- 6 box drawers with full pull-out
- 4 drawers with 85 mm or 2 drawers with 165 mm
- Central locking by means of profile cylinder lock
- 2 rubberised [non-marking] swivel casters and 2 rigid caster
- 2 swivel casters with locking mechanism, stainless steel wheel blocks

TYPE	DRAWERS	DIMENSIONS W x D x H in mm	ARTICLE NO.
WSW-6L	4x H: 85 mm + 2x H: 165 mm	500 x 650 x 910	20.00.00.86
WSW-6L/A	4x H: 85 mm + 2x H: 165 mm	500 x 650 x 950	20.00.00.87

**SPECIAL SOLUTIONS**



**TYPE WSW-8Q**

## Workshop trolleys

STAINLESS STEEL 1.4301



- Robust version for workshop use
- Work surface with surrounding 40mm backslash [corners with recess for optimal cleaning]
- Stable, shatterproof HDPE-500 plastic sheet, Colour: red-brown, t = 30 mm [inlaid]
- Push handle [crossbar] on the face
- 6 drawers with 80 mm or 2 drawers with 130 mm
- All box drawers with full pull-out
- Central locking by means of profile cylinder lock
- Mobile with 2 rubberised swivel casters and 2 rigidd casters
- Smooth-running and low-noise wheels [stainless steel ball bearings]
- Wheel blocks made of stainless steel

TYPE	DRAWERS	DIMENSIONS W x D x H in mm	ARTICLE NO.
WSW-8Q	6x H: 80 mm + 2x H: 130 mm	715 x 515 x 982	20.00.00.85

**OPTIONS**

Vice made of stainless steel [jaw width: 101.6 mm] on request

**TYPE WBKW**

## Workbench trolley

STAINLESS STEEL 1.4301



- Robust version for workshop use
- Work surface with surrounding beaded edge on 3 sides
- On the backside, with stainless steel perforated plate, H: 250 mm
- Underneath the work top; 2 box drawers, H: 85 mm
- All drawers with full pull-out, load-carrying capacity approx. 20 kg
- Push handle Ø 20mm [crossbar] on the face
- 2 storage boards with surrounding beaded edge, fixed
- Floor distance: 290 mm
- Mobile by means of 4 rubberised swivel casters, Ø 125 mm
- 2 swivel casters with locking devices, stainless steel steering box
- Smooth-running and low-noise wheels [stainless steel ball bearings]
- Wheel blocks made of stainless steel

TYPE	VERSION	DIMENSIONS W x D x H in mm	ARTICLE NO.
WBKW 90-50/3	2x drawers, H: 85 mm	900 x 500 x 950/ 1200	44.20.02.20

**OPTIONS**

Vice made of stainless steel [jaw width: 101.6 mm] on request

Lockable drawer Article no. 99.80.02.87



**TYPE WBK-S3L/R**

**Workbench**

STAINLESS STEEL 1.4301



- Table top, made of stainless steel, bevelled on all sides, fully lined with a V100 panel
- Stable frame construction made of square pipe
- Lower structure open, braced in U-shape
- Drawer unit optionally on the left or right side
- Drawer unit with 3 drawers (W 550 x D 600 mm)
- Drawers (full pull-out) 1x 90 mm / 2x 120 mm
- Lower structure strutted in U-shape (Hygienic Design)
- Height-adjustable stainless steel screw feet (level compensation)
- Ground clearance: 100 mm
- Incl. wall spacer in Hygienic-Design, D: 50 mm

TYPE	VERSION	DIMENSIONS	ARTICLE NO.
		W x D x H in mm	
WBK-S3L	Drawer unit on the left	1500 x 700 x 800	44.20.02.00
WBK-S3R	Drawer unit on the right	1500 x 700 x 800	44.20.02.01

**OPTIONS**

Vice made of stainless steel	on request
Tools made of stainless steel	on request
Lockable drawer	Article no. 99.80.02.87

**TYPE WBK-S6**

**Workbench**

STAINLESS STEEL 1.4301



- Table top, made of stainless steel, bevelled on all sides, fully lined with a V100 panel
- Stable frame construction made of square pipe
- Lower structure closed on 3 sides
- Drawer unit, left: 1x 90 / 1x 180 / 1x 270 mm
- Drawer unit, middle: 3x 180 mm
- Drawer unit, right: 3x 180 mm
- Locking system: All drawers are lockable
- Height-adjustable stainless steel screw feet (level compensation)
- Ground clearance: 100 mm
- Incl. wall spacer in Hygienic-Design, D: 50 mm

TYPE	DIMENSIONS	ARTICLE NO.
	W x D x H in mm	
WBK-S6	2000 x 700 x 800	44.20.02.10

**OPTIONS**

Vice made of stainless steel	on request
Tools made of stainless steel	on request
Lockable drawer	Article no. 99.80.02.87



## Tools made of stainless steel

STAINLESS STEEL 1.4301



On account of their numerous advantages, rust-free stainless steel tools are required mainly in the following application areas:

- High-care zones
- Pharmaceutical industry
- Medical technology
- Microelectronics
- Power plant technology
- Oil industry
- Sailing
- Plant of facade engineering
- In all sterile areas

We offer tools tailored for special requirements!

All tools on request!



**TYPE UWS**

**Environmental cabinet**

STAINLESS STEEL 1.4301



- Stable industrial version
- 2 hinged doors on the operator side
- Hinged door, lockable by means of T-handle with cylinder lock
- Doors with top and bottom ventilation slots
- Pitched roof, 200 mm higher at the back
- 4 welded insertion troughs
- Insertion troughs height-adjustable in a grid of approx. 17 mm
- Ground clearance: 100 mm
- Height-adjustable plastic screw feet (level compensation)
- Incl. wall spacer in Hygienic-Design, D: 50 mm

TYPE	DIMENSIONS	ARTICLE NO.
	W x D x H in mm	
UWS 95-50	950 x 500 x 2160	44.20.01.00

**TYPE ASM**

**Lifting tackle cabinet**

STAINLESS STEEL 1.4301



- Stable industrial version
- 2 hinged doors on the operator side
- Hinged door, lockable by means of T-handle with cylinder lock
- Doors with top and bottom ventilation slots
- Pitched roof, 200 mm higher at the back
- Internal rear wall, clad with wire mesh (MW 75 x 75 x 5 mm)
- Ground clearance: 100 mm
- Height-adjustable plastic screw feet (level compensation)
- Incl. wall spacer in Hygienic-Design, D: 50 mm

TYPE	DIMENSIONS	ARTICLE NO.
	W x D x H in mm	
ASM 95-50	950 x 500 x 2160	44.20.01.01

**OPTIONS**

Support (mandrel), projection: 300 mm Article no. 44.20.01.02

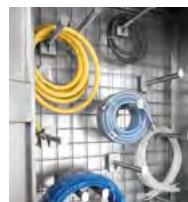

**TYPE SKS**

## Open-fronted storage cabinet

STAINLESS STEEL 1.4301



- Stable industrial version
- 2 hinged doors on the operator side
- Hinged door, lockable by means of T-handle with cylinder lock
- Doors with top and bottom ventilation slots
- Pitched roof, 200 mm higher at the back
- 12 height-adjustable, removable shelves suitable for:  
36 open-fronted storage boxes (160 x 105 x 75 mm) and  
24 open-fronted storage boxes (230 x 140 x 130 mm)
- Open-fronted storage boxes optionally available
- Ground clearance: 100 mm
- Height-adjustable plastic screw feet (level compensation)
- Incl. wall spacer in Hygienic-Design, D: 50 mm

TYPE	DIMENSIONS W x D x H in mm	ARTICLE NO.
SKS 74-30	740 x 300 x 2080	44.20.01.03

**OPTIONS**

Open fronted storage box 160 x 105 x 75 mm	on request
Open fronted storage box 230 x 140 x 130 mm	on request

**TYPE ASD-W**

## Workshop cabinet

STAINLESS STEEL 1.4301



- Stable industrial version
- 2 hinged doors on the operator side
- Hinged door, lockable by means of T-handle with cylinder lock
- Doors with top and bottom ventilation slots
- 4 height-adjustable shelves
- Pitched roof, 200 mm higher at the back
- Ground clearance: 100 mm
- Height-adjustable plastic screw feet (level compensation)
- Incl. wall spacer in Hygienic-Design, D: 50 mm

TYPE	DIMENSIONS W x D x H in mm	ARTICLE NO.
ASD-W 50	1200 x 500 x 2160	44.20.00.21

**TYPE AS**

**Storage cabinets**

STAINLESS STEEL 1.4301



Type AS Standard

**STORAGE CABINETS TYPE AS**

- Hinged doors with ventilation openings, pitched roof 200 mm
- AS: 4 height-adjustable stowage shelves
- AS-TD: Hat bottom and 3 height-adjustable storage shelves
- AS-TV: 3 height-adjustable storage shelves
- Cabinet body closed on three sides
- Version in 1.0 mm material thickness
- Pitched roof, 200 mm higher at the back, in Hygienic-Design
- 1 hinged door on the operator side
- Door with lockable T-handle including profile cylinder lock
- 4 height-adjustable plastic screw feet [+/- 30 mm]
- Standard ground clearance: 150 mm



Type AS interior



Type AS-TD interior



Type AS-TV interior

TYPE	DIMENSIONS W x D x H in mm	ARTICLE NO.
AS	500 x 500 x 2160	44.20.00.03
AS-TD	500 x 500 x 2160	44.20.00.02
AS-TV	500 x 500 x 2160	44.20.00.06

Other dimensions on request!

**OPTIONS**

4 polyamide swivel casters, Ø 125 mm [2 with stop] Article no. 99.90.01.50

**TYPE AS HIGHLINE**

# Storage cabinets

STAINLESS STEEL 1.4301



Type AS Highline

**STORAGE CABINETS TYPE AS/H**

- Hinged door with acrylic glass, sloping roof 200 mm
- AS/H: 4 height-adjustable stowage shelves
- AS-TD/H: Hat bottom and 3 height-adjustable storage shelves
- AS-TV/H: 3 height-adjustable storage shelves
- Cabinet body closed on three sides
- Version in 1.0 mm material thickness
- Pitched roof, 200 mm higher at the back, in Hygienic-Design
- 1 hinged door on the operator side
- Door with lockable T-handle including profile cylinder lock
- 4 height-adjustable plastic screw feet [+/- 30 mm]
- Standard ground clearance: 150 mm



Type AS/H interior



Type AS-TD/H interior



Type AS-TV/H interior

TYPE	DIMENSIONS W x D x H in mm	ARTICLE NO.
AS/H	500 x 500 x 2160	44.20.00.18
AS-TD/ H	500 x 500 x 2160	44.20.00.22
AS-TV/ H	500 x 500 x 2160	44.20.00.23

Other dimensions on request!

**OPTIONS**

4 polyamide swivel casters, Ø 125 mm [2 with stop] Article no. 99.90.01.50

**TYPE ASD**

**Storage cabinets**

STAINLESS STEEL 1.4301



TYPE ASD

**STORAGE CABINETS TYPE ASD**

- Hinged doors with ventilation openings, pitched roof 200 mm
- ASD: 4 height-adjustable stowage shelves
- ASD-TD: Hat bottom and 3 height-adjustable storage shelves
- ASD-TV: 3 height-adjustable storage shelves
- Cabinet body closed on three sides
- Version in 1.0 mm material thickness
- Pitched roof, 200 mm higher at the back, in Hygienic-Design
- 2 hinged doors on the operator side
- Doors lockable by means of T-handle including profile cylinder lock
- 1 solidly welded hat shelf [Type ASD-TD]
- Cabinet interior, with 3 height-adjustable storage shelves on the side [only Type ASD-TD/ ASD-TV]
- Cabinet interior with shortened partition wall [Type ASD-TV]
- Cabinet interior with continuous partition wall up to the bottom [Type ASD-TD]
- 4 height-adjustable plastic screw feet [+/- 30 mm]
- Standard ground clearance: 150 mm



Type ASD interior



Type ASD-TD interior



Type ASD-TV interior

TYPE	DIMENSIONS W x D x H in mm	ARTICLE NO.
ASD	950 x 500 x 2160	44.20.00.15
ASD-TD	950 x 500 x 2160	44.20.00.04
ASD-TV	950 x 500 x 2160	44.20.00.24

**OPTIONS**

4 polyamide swivel casters, Ø 125 mm [2 with stop] Article no. 99.90.01.50

Other dimensions on request!



**TYPE ASD HIGHLINE**

# Storage cabinets

STAINLESS STEEL 1.4301



**TYPE ASD** Highline

**STORAGE CABINETS TYPE ASD/H**

- Hinged doors with acrylic glass; sloping roof 200 mm
- ASD/H: 4 height-adjustable storage shelves
- ASD-TD/H: Hat bottom and 3 height-adjustable storage shelves
- ASD-TV/H: 3 height-adjustable storage shelves
- Cabinet body closed on three sides
- Version in 1.0 mm material thickness
- Pitched roof, 200 mm higher at the back, in Hygienic-Design
- 2 hinged doors on the operator side
- Doors lockable by means of T-handle including profile cylinder lock
- 1 solidly welded hat shelf [Type ASD-TD/H]
- Cabinet interior, with 3 height-adjustable storage shelves on the side [only Type ASD-TD/H; ASD-TV/H]
- Cabinet interior with shortened partition wall [Type ASD-TV/H]
- Cabinet interior with continuous partition wall up to the bottom [Type ASD-TD/H]
- 4 height-adjustable plastic screw feet [+/- 30 mm]
- Standard ground clearance: 150 mm



**Type ASD/H** interior



**Type ASD-TD/H** interior



**Type ASD-TV/H** interior

TYPE	DIMENSIONS W x D x H in mm	ARTICLE NO.
ASD/H	950 x 500 x 2160	44.20.00.17
ASD-TD/ H	950 x 500 x 2160	44.20.00.25
ASD-TV/ H	950 x 500 x 2160	44.20.00.26

Other dimensions on request!

**OPTIONS**

4 polyamide swivel casters, Ø 125 mm [2 with stop] Article no. 99.90.01.50

**TYPE ASD-F 10, -GRID, -HOLE**  
**Compartment cabinet**

STAINLESS STEEL 1.4301



Type ASD-F 10

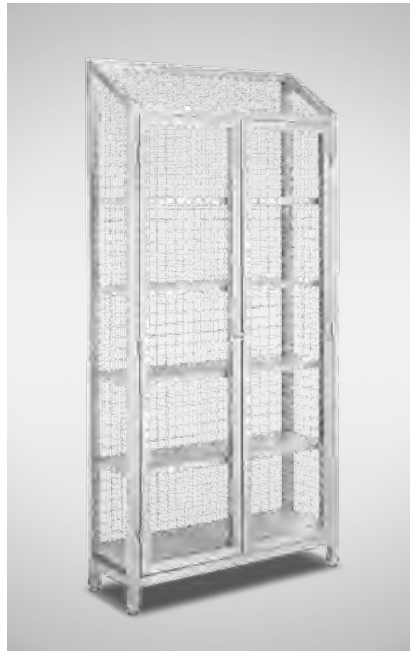

Type ASD Grid

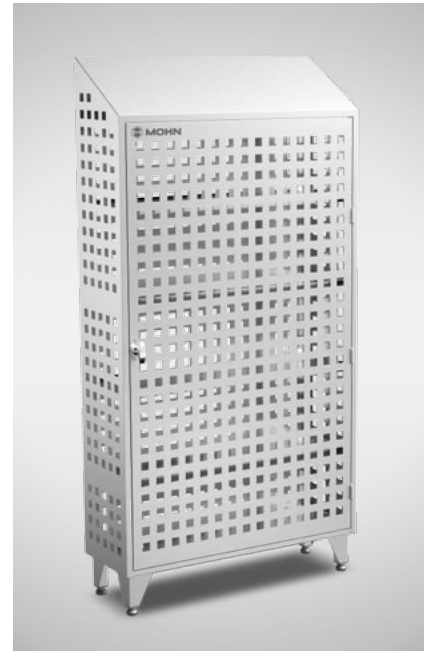

Type ASD Hole

- 2 hinged doors on the operator side
- Hinged doors lockable by means of T-handle
- 10 stowage shelves
- 8 height-adjustable compartment shelves
- Cabinet body closed on three sides
- Version in 1.0 mm material thickness
- Pitched roof, 200 mm higher at the back, in Hygienic-Design
- Labelling strip for numbering or names
- Cabinet interior with height-adjustable storage shelves
- 4 height-adjustable plastic screw feet (+/- 30 mm)
- Standard ground clearance: 150 mm
- Walls also available in mesh or perforated sheet design

**OPTIONS**

4 polyamide swivel casters, Ø 125 mm [2 with stop] Article no. 99.90.01.50

Highline version for storage cabinet Type ASD-F Article no. 49.00.19.05

Hinged doors made of acrylic glass for storage cabinet Type ASD-F Article no. 49.00.19.07

TYPE	DIMENSIONS W x D x H in mm	ARTICLE NO.
ASD-F 10	950 x 500 x 2160	29.00.00.10
ASD Grid 100-35	950 x 500 x 2160	44.20.09.00
ASD Hole 100-35	950 x 500 x 2160	44.20.09.10



Type ASD-F 10, interior

Your can find further compartment cabinets in open and closed version from Page 192.

**TYPE PMS**

## Cleaning agents cabinet

STAINLESS STEEL 1.4301



Type PMS, interior

- 9 stowage shelves for cleaning utensils
- Cabinet interior with 6 height-adjustable compartment shelves [3 each on the left and right side]
- Cabinet body closed on three sides
- Version in 1.0 mm material thickness
- For wall mounting [Type PMS-W] or 4 height-adjustable screw feet [Type PMS-S]
- Pitched roof, 200 mm higher at the back, in Hygienic-Design
- 2 hinged doors on the operator side lockable by means of T-handle including profile cylinder lock
- Spacious division compartment in the middle, for brooms, Scrubbing brushes and buckets
- Open ground area for better drying
- Standard ground clearance: 150 mm [Type PMS-S]

TYPE	VERSION	DIMENSIONS	ARTICLE NO.
		W x D x H in mm	
PMS-W	wall-mounted	800 x 400 x 1900	44.10.00.02
PMS-S	on feet	800 x 400 x 2050	44.10.00.00

**TYPE FS-12**

## Compartment cabinet

STAINLESS STEEL 1.4301



Type FS-12

- 12 stowage shelves [welded]
- Compartment clearance: W: 370 x D: 495 x H: 280 mm
- Labelling strip for numbering etc.
- Cabinet body closed on three sides
- Version in 1.0 mm material thickness
- Pitched roof, 200 mm higher at the back, in Hygienic-Design
- Labelling strip for numbering or names
- 4 height-adjustable plastic screw feet [+/- 30 mm]
- Standard ground clearance: 150 mm

**OPTIONS**

4 polyamide swivel casters, Ø 125 mm [2 with stop] Article no. 99.90.01.50

TYPE	DIMENSIONS	ARTICLE NO.
	W x D x H in mm	
FS-12	800 x 500 x 2200	29.00.00.31

Your can find further compartment cabinets in open and closed version from Page 192.

## Compartment cabinets as desired by the customer

---

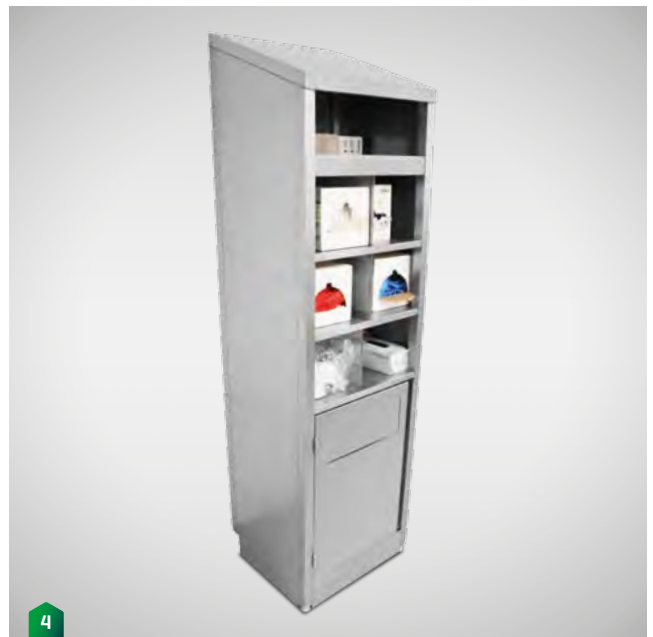
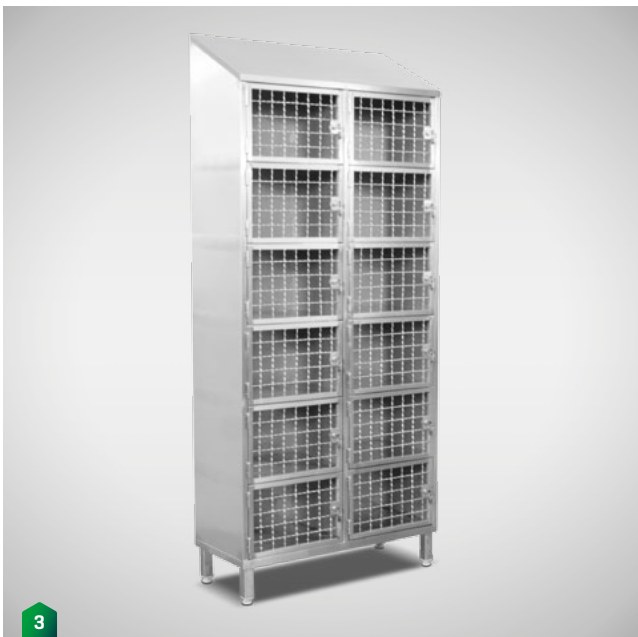

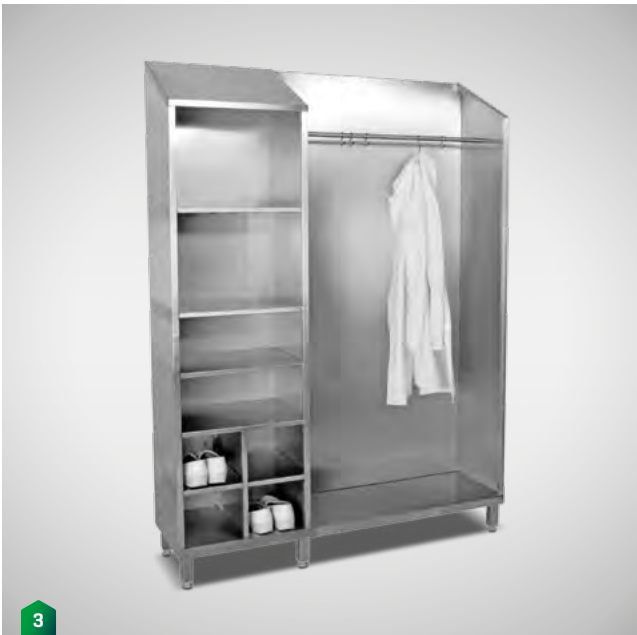
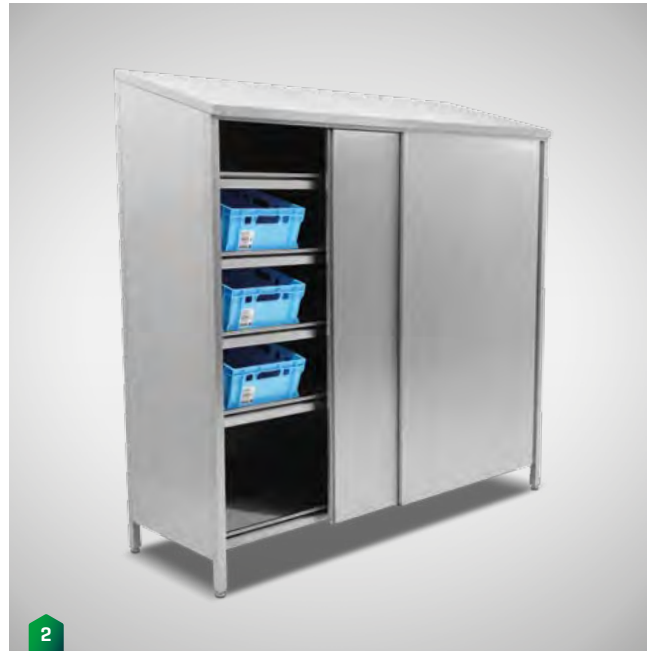

**TYPE PCS**  
**PC cabinets**



Type PCS-W



Type PCS-S/-F

**TYPE PCS-W**

TYPE	COMPARTMENTS*	DIMENSIONS W x D x H in mm	ARTICLE NO.
PCS-W	Mo / Ta / Ma	650 x 620 x 830	90.00.00.43

\*Mo=Monitor; Ta=Keyboard; Ma=Mouse

**TYPE PCS-W**

- 1 hinged door on the operator side and folding compartment for keyboard and mouse
- Wall-mounted version
- Hinged door with monitor window made of polycarbonate, lockable
- Keyboard and mouse tray with telescopic pull-out

**OPTIONS**

HD-wall spacer	see page 301
Body protected against water jets [IP65]	on request

**TYPE PCS-S/-F**

TYPE	COMPARTMENTS*	DIMENSIONS W x D x H in mm	ARTICLE NO.
PCS-S	Mo/ Ta/ Ma/ Re/ Dr	650 x 620 x 1700	90.00.00.28
PCS-F	Mo/ Ta/ Ma/ Re/ Dr	650 x 620 x 1700	90.00.00.69

Mo=Monitor; TA=Keyboard; Ma=Mouse, Re=Computer unit, Dr=Printer

**TYPE PCS-S/-F**

- 2 hinged doors on the operator side and folding compartment for keyboard, lockable
- Floor model, on 4 height-adjustable screw feet [PCS-S] or movable on 4 polyamide swivel casters [PCS-F]
- Hinged door with monitor window made of polycarbonate
- Keyboard and mouse tray with high-quality telescopic pull-out
- Storage compartment at the bottom for printers or other peripherals



Type PCS-W 2, with optional HD wall spacer

We produce all cabinets also individually as desired by the customer!

**PC CABINETS TYPE PCS**

- Cabinet body closed on three sides
- Version in 1.0 mm material thickness
- Splash water-proof version, protection class: IP54
- Hinged door[s] with polycarbonate window on the operator side
- Door[s] lockable

**TYPE PCS-W 2**

TYPE	COMPARTMENTS*	DIMENSIONS W x D x H in mm	ARTICLE NO.
PCS-W2	Mo / Ta / Ma / Dr	555 x 360 x 1160	90.00.02.02

Ma=Monitor; Ta=Keyboard; Ma=Mouse, Dr=Printer

**TYPE PCS-W 2**

- 2-part, wall-mounted PC cabinet design
- Cabinet version with hygienic wall spacers [optional]
- Monitor wall-mounted cabinet, below with open keyboard tray
- Underneath printer cabinet with lateral door for labels output
- Cabinet, top and bottom with lockable hinged door

**OPTIONS**

HD-wall spacer	see page 301
Body protected against water jets [IP65]	on request

**MATERIAL**

- Stainless steel furniture made of chrome-nickel steel 18/10 material No. 1.4301
- The externally visible stainless steel sheet surfaces have a 320 grit polished finish.



HD-wall spacer



## PC cabinets as desired by the customer

STAINLESS STEEL 1.4301



**TYPE HD-WA**

**HD-wall spacer**

STAINLESS STEEL 1.4301



TYPE	MOUNTING	DIMENSIONS W x H mm	ARTICLE NO.
HD-WA 50	Bolting	50 x 30	99.80.06.00

Provides space for the cleaning behind the housing as well!

- Hygienic-Design
- Massive solid steel
- Length: 50 mm
- Thread size: M 10
- Diameter: 30 mm

**TYPE GWB**

## Spice rack

STAINLESS STEEL 1.4301



- Rack, flanged on 3 sides, chamfered on the front
- Side walls closed

TYPE	VERSION	DIMENSIONS W x D x H in mm	ARTICLE NO.
GWB-2	2-level	1000 x 250 x 400	21.00.20.05

**TYPE WB-A**

## Wall board

STAINLESS STEEL 1.4301



- Dimensions as desired by the customer!
- Welded wall board
- Consoles for wall mounting with key hole drilling

TYPE	VERSION	DIMENSIONS W x D in mm	ARTICLE NO.
WB-A	1-level	as desired*	20.00.00.73

\*by the customer

**TYPE WB-B**

# Wall board

STAINLESS STEEL 1.4301



- Dimensions as desired by the customer!
- Version in 1.0 mm material thickness
- Board underside open
- Boards, chamfered on 3 sides, rear 25 mm flanged
- Boards height-adjustable, 100 mm grid
- Incl. Wall-mounted rail (800 mm long) for height adjustment

TYPE	VERSION	DIMENSIONS W x D in mm	ARTICLE NO.
WB-B 1	1-level	as desired*	20.00.02.75
WB-B 2	2-level	as desired*	20.00.02.43
WB-B 3	3-level	as desired*	20.00.02.23

\*by the customer

**OPTIONS**

Shelf underside closed for "high-risk" areas on request

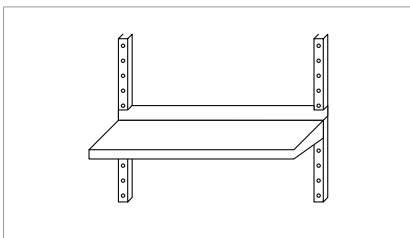

Type WB-B 1

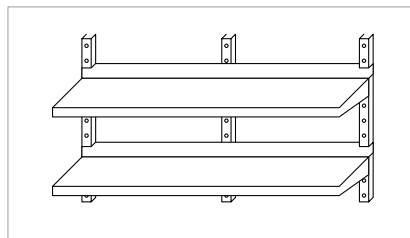

Type WB-B 2

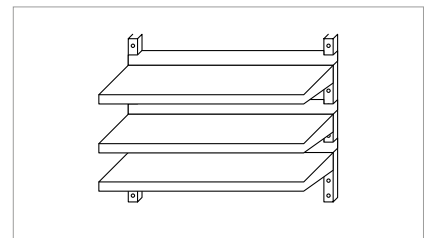

Type WB-B 3

**TYPE SR HIGHLINE**

# System rack

---



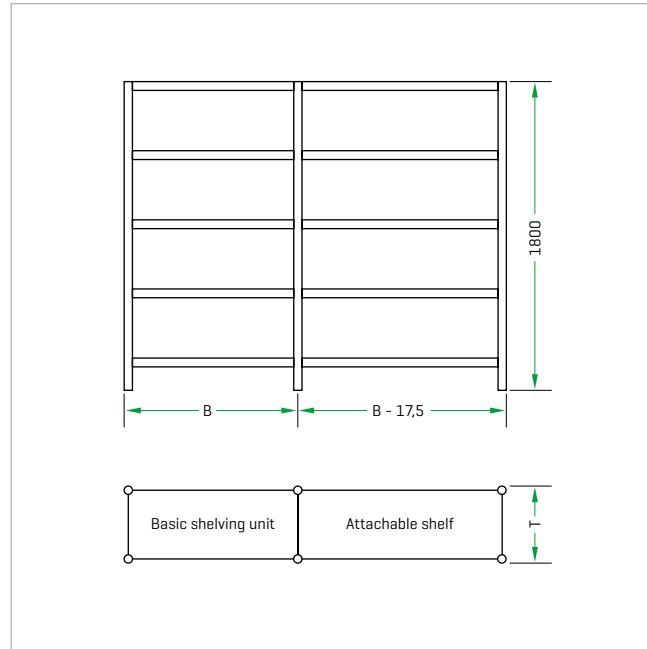

Basic shelving unit with attachable shelves

- Advantage: Span width up to max. 1,900 mm
- Easy screw mounting
- Robust and hygienic round pipe supports (height: 1,800 mm)
- Height adjustment grid: 200 mm (or as requested)
- 200 kg load-bearing capacity per running meter (with evenly distributed load)
- 2 standard shelf depths: 430 or 550 mm (or as requested)
- Shelf lengths: 100 mm grid (or as requested)
- Compartment shelves closed
- Height-adjustable screw feet for level compensation

**OPTIONS**

Perforated compartment shelves on request

**BASIC SHELVING UNIT, CONSISTING OF:**

- 4 compartment shelves and 4 supporting feet

**ATTACHABLE SHELVES CONSISTING OF:**

- 4 compartment shelves and 2 supporting feet

9 compartment shelves possible per shelf!

DEPTH in mm	WIDTH in mm	ARTICLE NO. Basic shelving unit	ARTICLE NO. Attachable shelf	ARTICLE NO. Additional shelf
430	800	49.10.10.32	49.10.01.32	49.10.00.32
	900	49.10.10.33	49.10.01.33	49.10.00.33
	1000	49.10.10.34	49.10.01.34	49.10.00.34
	1100	49.10.10.35	49.10.01.35	49.10.00.35
	1200	49.10.10.36	49.10.01.36	49.10.00.36
	1300	49.10.10.37	49.10.01.37	49.10.00.37
	1400	49.10.10.38	49.10.01.38	49.10.00.38
	1500	49.10.10.39	49.10.01.39	49.10.00.39
	1600	49.10.10.42	49.10.01.42	49.10.00.70
	1700	49.10.10.40	49.10.01.40	49.10.00.40
550	1800	49.10.10.43	49.10.01.43	49.10.00.71
	1900	49.10.10.41	49.10.01.41	49.10.00.41
	800	49.10.10.56	49.10.01.56	49.10.00.56
	900	49.10.10.57	49.10.01.57	49.10.00.57
	1000	49.10.10.58	49.10.01.58	49.10.00.58
	1100	49.10.10.59	49.10.01.59	49.10.00.59
	1200	49.10.10.60	49.10.01.60	49.10.00.60
	1300	49.10.10.61	49.10.01.61	49.10.00.61
	1400	49.10.10.62	49.10.01.62	49.10.00.62
	1500	49.10.10.63	49.10.01.63	49.10.00.63
	1600	49.10.10.66	49.10.01.66	49.10.00.72
	1700	49.10.10.64	49.10.01.64	49.10.00.64
	1800	49.10.10.67	49.10.01.67	49.10.00.73
	1900	49.10.10.65	49.10.01.65	49.10.00.65

**TYPE MR**

# Modular shelf system

STAINLESS STEEL 1.4301



Basic shelving Type MR-4B/ 06, 5 shelves



Basic shelving with add-on shelving Type MR-4B/ 06 as a corner solution, 5 shelves

- GS mark
- 2 different shelf versions and bay loads
- Stainless steel surfaces: Shelves: Grain 240 Duplo finish  
Shelving frame: Electrolytically polished
- Shelf optionally closed [B] or with slotted holes [R]
- Bay load optionally 600 kg or 1,200 kg
- Shelf lengths: 600 mm to 1,500 mm [in 100 mm increments]
- Standard shelf depths: 300 mm to 600 mm [in 100 mm increments]
- Height adjustment grid for shelves: 165 mm [attachment pins]
- Shelving frame height: 1,800 mm [standard], 1,500 and 2,000 mm [optional]

**STANDARD BASIC SHELF, CONSISTING OF**

- 2 shelving frames (H: 1,800 mm)
- 4 closed or perforated shelves
- 1 diagonal strut for stiffening

**STANDARD ATTACHABLE SHELF, CONSISTING OF**

- 1 shelving frames (H: 1,800 mm)
- 4 closed or perforated shelves



1 Shelf closed



2 Shelf perforated

TYPE	VERSION	BAY LOAD*	ARTICLE NO.
MR-4B/ 06	Shelves, closed	600 kg	99.10.01.05
MR-4R/ 06	Shelves, perforate	600 kg	99.10.01.06
MR-4B/ 12	Shelves, closed	1,200 kg	99.10.01.03
MR-4R/ 12	Shelves, perforate	1,200 kg	99.10.01.04

\* The maximum bay load is calculated from the sum of the individual compartment loads/shelf bay



Basic shelving with add-on shelves Type MR-4B/ 06 in U-shape



**TYPE SRS**

## Sliding shelves system

STAINLESS STEEL 1.4301



Sliding shelves system

- The basis is the modular shelf system Type MR
- Shelf depths: 400, 500 and 600 mm up to a total length of 3,000 mm possible
- Shelving frame height 1,500 mm, 1,800 mm or 2,000 mm possible
- Mobile base frames with ball bearing mounted rollers
- One-row or two-row base frames [back to back]
- Take-up device for modular shelf systems
- Stainless steel rail system, depending on the room size

TYPE	VERSION	BAY LOAD*	ARTICLE NO.
SRS B/ 06	Shelves, closed	600 kg	99.10.01.08
SRS R/ 06	Shelves, perforate	600 kg	99.10.01.09
SRS B/ 12	Shelves, closed	1,200 kg	99.10.01.11
SRS R/ 12	Shelves, perforate	1,200 kg	99.10.01.12

\* The maximum bay load is calculated from the sum of the individual compartment loads/shelf bay

**TYPE LS**

**Storage system**

FOOD-SAFE PLASTIC



- Tested and certified by RW/TÜV; GS mark (proven safety)
- HACCP compliant
- Temperature resistant from -40 °C to +80 °C
- Stable and impact-resistant, load-carrying capacity 200 kg per running meter
- Profiles: 50 x 50 mm
- External overhang: 25 mm each
- Shelf depth from 300 mm up to 1,000 mm (100 mm grid)
- Level spacing selectable from 100 mm to 500 mm
- Max. clear dimension (width): 1,000 mm
- Standard supporting feet, not height-adjustable
- Ground clearance: 120 mm [supporting feet] / 170 mm [mobile]
- Shelves open [optional: removable shelves]

TYPE	VERSION	LOAD BEARING CAPACITY	ARTICLE NO.
LS	Shelves, open	200 kg/m	99.10.00.20

**OPTIONS**

Mobile with 4 swivel casters, 2 with stop	Article no. 44.10.01.01
Height-adjustable screw feet, from 200 mm ground clearance	Article no. 44.10.01.02
Top supports, sideways (height: +150 mm)	on request
Corner connectors for shelves which can be hung up (corner shelf)	on request
Removable shelves (white) for small products	on request

Shelf length as required up to 4,000 mm

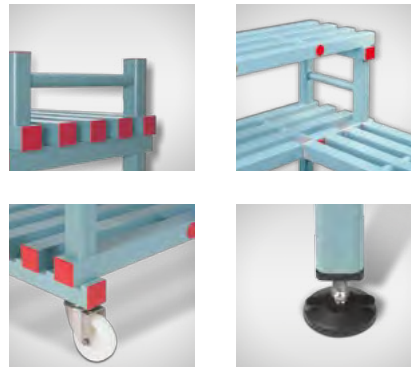

**TYPE LR-K**

# Storage rack

FOOD-SAFE PLASTIC



Type LR-K 3/3 optional with swivel caster



TYPE	LEVELS	CAPACITY per level	DIMENSIONS W x D x H in mm	ARTICLE NO.
LR-K 3/3	3	3 boxes	1380 x 600 x 1520	59.01.00.25
LR-K 4/3	4	3 boxes	1380 x 600 x 2070	59.01.00.13

- Storage rack, optionally 3-level to 4-level
- Container can be positioned inclined or straight
- Shelf depth: 600 mm
- Floor distance: 500 mm
- Standard supporting feet, not height-adjustable
- Ground clearance: 120 mm [supporting feet] / 170 mm [mobile]
- Top supports, sideways [standard]

**ADVANTAGES**

- Tested and certified by RW/TÜV; GS mark [proven safety]
- Hygienically according to HACCP requirements
- Temperature resistant from -40 °C to +80 °C
- Stable and impact-resistant, load-carrying capacity 200 kg per running meter
- Resistant to food salts and acids

**OPTIONS**

Mobile with 4 swivel casters, 2 with stop	Article no. 44.10.01.01
Height-adjustable screw feet, from 200 mm ground clearance	Article no. 44.10.01.02

**TYPE LR-E**

**Storage rack**

STAINLESS STEEL 1.4301



Storage rack Type LR-E 4/4 without stacking frame



Detail: Round tube in the front

TYPE	LEVELS	CAPACITY per level	DIMENSIONS W x D x H in mm	ARTICLE NO.
LR-E 4/2	4	2 boxes	900 x 610 x 1275/ 1425	39.01.00.12
LR-E 4/3	4	3 boxes	1340 x 610 x 1275/ 1425	39.01.00.13
LR-E 4/4	4	4 boxes	1760 x 610 x 1275/ 1425	39.01.00.14
LR-E 4/5	4	5 boxes	2180 x 610 x 1275/ 1425	39.01.00.15
LR-E 4/6	4	6 boxes	2640 x 610 x 1275/ 1425	39.01.00.16
LR-E 4/7	4	7 boxes	3000 x 610 x 1275/ 1425	39.01.00.17
LR-E 5/2	5	2 boxes	900 x 610 x 1590/ 1740	39.01.00.02
LR-E 5/3	5	3 boxes	1340 x 610 x 1590/ 1740	39.01.00.03
LR-E 5/4	5	4 boxes	1760 x 610 x 1590/ 1740	39.01.00.04
LR-E 5/5	5	5 boxes	2180 x 610 x 1590/ 1740	39.01.00.05
LR-E 5/6	5	6 boxes	2640 x 610 x 1590/ 1740	39.01.00.06
LR-E 5/7	5	7 boxes	3000 x 610 x 1590/ 1740	39.01.00.07
LR-E 6/2	6	2 boxes	900 x 610 x 1905/ 2055	39.01.00.32
LR-E 6/3	6	3 boxes	1340 x 610 x 1905/ 2055	39.01.00.33
LR-E 6/4	6	4 boxes	1760 x 610 x 1905/ 2055	39.01.00.34
LR-E 6/5	6	5 boxes	2180 x 610 x 1905/ 2055	39.01.00.35
LR-E 6/6	6	6 boxes	2640 x 610 x 1905/ 2055	39.01.00.36
LR-E 6/7	6	7 boxes	3000 x 610 x 1905/ 2055	39.01.00.37

ARTICLE NO. Stacking frame option
39.91.00.02
39.91.00.03
39.91.00.04
39.91.00.05
39.91.00.06
39.91.00.07
39.91.00.02
39.91.00.03
39.91.00.04
39.91.00.05
39.91.00.06
39.91.00.07
39.91.00.02
39.91.00.03
39.91.00.04
39.91.00.05
39.91.00.06
39.91.00.07

- Storage rack, optionally 4-level to 6-level
- Stable, welded version
- Compartment shelves, closed with slope, 150 mm higher at the back
- Hygienic round pipe profile on the operator side
- Without stacking frame (optionally available)
- Floor distance approx. 285 mm, bottom: approx. 485 mm
- 4 height-adjustable plastic screw feet (+/- 30 mm)
- Ground clearance 100 mm (front)
- Profile tube 40 x 40 x 1.5 mm [Posts / Frames]
- Base plate 1.2 mm with hat profile reinforced
- Handrails, round tube Ø 20 x 1.5 mm
- With optional stacking frame: H + 260 mm
- With optional polyamide swivel casters: H: + 155 mm

**OPTIONS**

Stacking frame	Article no. see table
4 polyamide swivel casters, 2 with stop	Article no. 39.91.00.08
Centrally divided version	on request

**TYPE LR-E/U**

# Storage rack

STAINLESS STEEL 1.4301



Storage shelving LR-E/U 2/4/4 with optional stacking frame



TYPE	BOXES side by side	DIMENSIONS W x D x H in mm	ARTICLE NO.
LR-E/U 2/1/1	1	530 x 730 x 1400/1550	39.01.01.11
LR-E/U 2/2/2	2	960 x 730 x 1400/1550	39.01.01.12
LR-E/U 2/3/3	3	1390 x 730 x 1400/1550	39.01.01.13
LR-E/U 2/4/4	4	1820 x 730 x 1400/1550	39.01.01.14
LR-E/U 2/5/5	5	2310 x 730 x 1400/1550	39.01.01.15
LR-E/U 2/6/6	6	2740 x 730 x 1400/1550	39.01.01.16
LR-E/U 2/7/7	7	3170 x 730 x 1400/1550	39.01.01.17

ARTICLE NO. with stacking frame
---
39.91.00.02
39.91.00.03
39.91.00.04
39.91.00.05
39.91.00.06
39.91.00.07

For optimum storage of Euronorm containers [E1 - E3] in accordance with DIN EN 55423 and storage of Rollis

- Storage rack with 2 levels and a capacity for up to 7 boxes side by side
- Stable, welded version
- Compartment shelves, closed with slope, 150 mm gradient at the back
- Hygienic round pipe profile on the operator side
- Floor distance approx. 500 mm on top
- Ground clearance 800 mm [front]
- 4 height-adjustable screw feet
- With optional stacking frame:  
H + 260 mm
- With optional polyamide swivel casters:  
H: + 155 mm

**OPTIONS**

Stacking frame	Article no. see table
4 polyamide swivel casters, 2 with stop	Article no. 39.91.00.08

**TYPE PRS**

# Pallet rack system

STAINLESS STEEL 1.4301

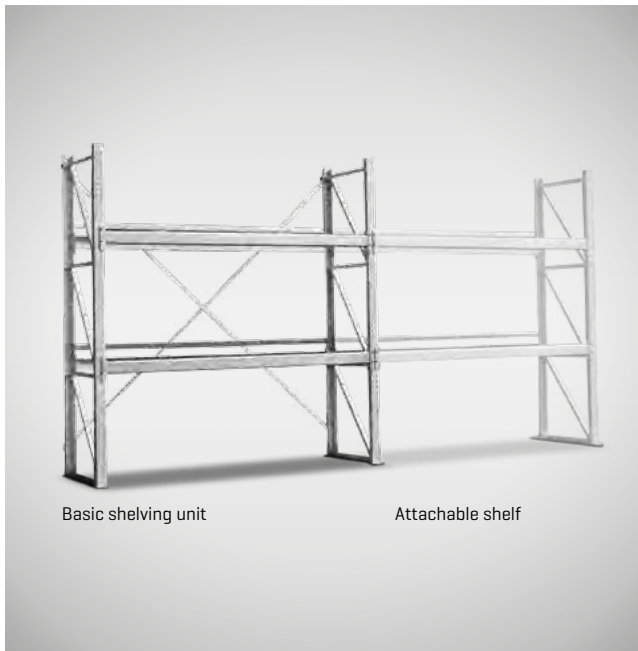

Basic shelving unit with attachable shelves

- Welded rack frames with load-bearing capacity 11,000 kg
- Perforated in the 100 mm grid
- Shelf depths optionally 800 mm or 1,100 mm
- Field widths: 1,800, 2,700, 3,600 mm possible
- Frame heights [11 t load capacity]: 1,800, 2,000, 2,500, 3,000, 3,500, 4,000 and 4,500 mm possible
- Frame heights [1 t load capacity]: 2,500, 3,000, 3,500, 4,000, 4,500 and 5,000 mm possible
- Longitudinal crossbars with welded screw-on brackets
- Diagonal cross for stiffening, with turnbuckles

**OPTIONS**

Reinforcement traverse [one field required in case of 1 traverse]	on request
Tilt protection [in case of field widths from 3 m]	on request
Bumper buffer device	on request
Push-trough protection [0 or 50 mm]	on request
Compartment covers	on request
Bolt anchors/ heavy-duty anchors	on request

TYPE	SHELF DEPTH in mm	LOAD BEARING CAPACITY	ARTICLE NO.
PRS-08/ 11 t	800 - lateral bearing	9,000 kg	99.10.01.15
PRS-08/ 11 t	800 - lateral bearing	12,000 kg	99.10.01.17
PRS-11/ 11 t	1,100 - longitudinal bearing	9,000 kg	99.10.01.16
PRS-11/ 11 t	1,100 - longitudinal bearing	12,000 kg	99.10.01.18

**INSTALLATION EXAMPLE**

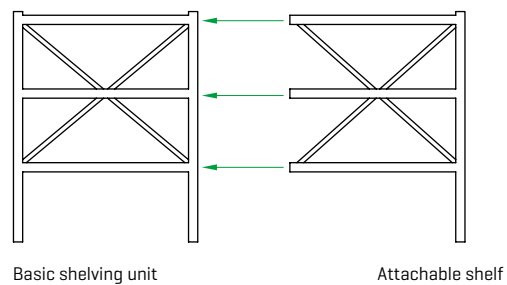

**3 LONGITUDINAL TRAVERSES WITH DIAGONAL CROSS**

SHELF VERSION	HEIGHT in mm	FIELD WIDTH in mm	COMPARTMENT LOAD	DEPTH in mm
Basic shelving unit	2,500	1,800	2,400 kg	1,100
Basic shelving unit	2,500	2,700	3,000 kg	1,100
Attachable shelf	2,500	1,800	2,400 kg	1,100
Attachable shelf	2,500	2,700	3,000 kg	1,100



Optional bumper buffer device



## Practical example

---



Stainless steel pallet racking with gratings and drip tray



# 5



# 05

## Process / transport technology

Smoke trolleys

---

Sausage cart

---

Defrosting trolleys

---

Grid frames

---

Smoking skewers

---

Smoke stick trolley

---

**TYPE RW**

# Smoke trolleys



Type RW-VH

- Smoke trolleys Type RW-H-Shape with support No. 5
- For 1,000 and 900 mm smoking skewers and frames W: 940 x D: 990 mm

TYPE	LEVELS	CLEAR FLOOR DISTANCE	ARTICLE NO. 900 mm*	ARTICLE NO. 1,000 mm*
RW-VH 5E5A	5	380 mm	40.00.09.00	40.00.10.00
RW-VH 6E5A	6	305 mm	40.00.09.01	40.00.10.01
RW-VH 7E5A	7	255 mm	40.00.09.02	40.00.10.02
RW-VH 8E5A	8	220 mm	40.00.09.03	40.00.10.03
RW-VH 9E5A	9	190 mm	40.00.09.04	40.00.10.04
RW-VH 10E5A	10	170 mm	40.00.09.05	40.00.10.05

\* Length of the smoking skewers

**VERSIONS TYPE RW-VH, -VZ, -VM**

- Stable frame construction 50 x 30 x 1.5 m made of stainless steel
- Cleanly welded and first-class stained
- Lowest level 300 mm above floor
- Total load max. 500 kg
- With 2 push handles on each side, vertically offset



Type RW-VZ

- Smoke trolleys Type RW-Z-Shape with support No. 5
- For 1,000 mm and 900 mm smoking skewers and frames W: 940 x D: 990 mm

TYPE	LEVELS	CLEAR FLOOR DISTANCE	ARTICLE NO. 900 mm*	ARTICLE NO. 1,000 mm*
RW-VZ 5E5A	5	330 mm	40.00.09.06	40.00.10.06
RW-VZ 6E5A	6	270 mm	40.00.09.07	40.00.10.07
RW-VZ 7E5A	7	230 mm	40.00.09.08	40.00.10.08
RW-VZ 8E5A	8	200 mm	40.00.09.09	40.00.10.09
RW-VZ 9E5A	9	180 mm	40.00.09.10	40.00.10.10
RW-VZ 10E5A	10	160 mm	40.00.09.11	40.00.10.11

\* Length of the smoking skewers

- 6 polyamide rigid casters (diameter 150 mm), centre wheel pair elevated for tilting moment
- With TARE sticker on both sides
- Stable wheel carrier made of profile tube 80 x 40 x 2 mm
- Wheels designed for up to 130 °C  
Dimensions: W: 915 or 1,015 x D: 900 or 1,000 x H: 1,950 mm



Type RW-VM

- Smoke trolley Type RW-M-Shape with support No. 5
- For 1,000 and 900 mm smoking skewers and frames W: 940 x D: 990 mm

TYPE	LEVELS	CLEAR FLOOR DISTANCE	ARTICLE NO. 900 mm*	ARTICLE NO. 1,000 mm*
RW-VM 5E5A	5	330 mm	40.00.09.12	40.00.10.12
RW-VM 6E5A	6	270 mm	40.00.09.13	40.00.10.13
RW-VM 7E5A	7	230 mm	40.00.09.14	40.00.10.14
RW-VM 8E5A	8	200 mm	40.00.09.15	40.00.10.15
RW-VM 9E5A	9	180 mm	40.00.09.16	40.00.10.16
RW-VM 10E5A	10	160 mm	40.00.09.17	40.00.10.17

\* Length of the smoking skewers



Type RW-VH

- Smoke trolley Type RW-H-Shape with L-support
- For frames W 940 x D 990 mm

TYPE	LEVELS	CLEAR FLOOR DISTANCE	ARTICLE NO.
RW-VH 22E	22	72 mm	40.00.10.30

**VERSION TYPE RW-VH 22E**

- Stable frame construction made of square pipe 50 x 30 x 1.5 in H-shape
- Angular support 30 mm wide, 20 mm high
- With end stop on both sides
- 1. Level in 250 mm height
- For grid frames 940 x 990 mm
- Open wheel case made of square pipe 80 x 40 x 2 mm
- Lower cross beam in 240 mm U.K.
- 2 horizontal push handles on each side made of round material, D = 12 mm, 150 mm long, offset in height
- 6 polyamide wheels [D = 150 mm] with tilting torque
- Wheels heat-resistant up to 130°C
- Load bearing capacity: 600 kg
- Dimensions: W: 1,010 x D: 1,010 x H: 2,000 mm

**TYPE ATW-V, RKW-VM**

**Defrosting, cooking and smoking trolleys**

STAINLESS STEEL 1.4301



Defrosting trolley, Type ATW-V



Cooking and smoke trolley Type RKW-VM

TYPE	LEVELS	CLEAR FLOOR DISTANCE	ARTICLE NO.
ATW-V 5E	5	310 mm	40.00.10.18
ATW-V 6E	6	250 mm	40.00.10.19
ATW-V 7E	7	210 mm	40.00.10.20
ATW-V 8E	8	180 mm	40.00.10.21
ATW-V 9E	9	160 mm	40.00.10.22
ATW-V 10E	10	140 mm	40.00.10.23

TYPE	LEVELS	CLEAR FLOOR DISTANCE	ARTICLE NO.
RKW-VM 5E	5	330 mm	40.00.10.24
RKW-VM 6E	6	270 mm	40.00.10.25
RKW-VM 7E	7	230 mm	40.00.10.26
RKW-VM 8E	8	200 mm	40.00.10.27
RKW-VM 9E	9	180 mm	40.00.10.28
RKW-VM 10E	10	160 mm	40.00.10.29

**DEFROSTING TROLLEY, TYPE ATW-V**

- Stable frame construction made of stainless steel
  - Cleanly welded and first-class stained
  - Load per level 50 kg
  - Total load max. 500 kg
  - With solidly welded grid frames made of wavy grate, MW 40 x 40 x 3 mm, frame made of angle profile 30 x 30 x 3 mm
  - Outer supports made of angle profile 40 x 40 x 4mm
  - Wheel carrier made of profile tube 80 x 40 x 2 mm, cross-connectors made of Profile tube 40 x 40 x 2 mm
  - 6 polyamide rigid casters (diameter 150 mm), centre wheel pair elevated for tilting moment
  - Wheels designed for up to 95 °C
- Dimensions: W: 1,010 x D: 1,006 x H: 1,980 mm

**COOKING AND SMOKE TROLLEY TYPE RKW-VM**

- Firmly welded version in M-shape
  - Frame made of profile tube 40 x 40 x 1.5 mm
  - Supports made of round steel D = 10 mm, distance between the steels 50 mm each
  - Undercarriage open, wheel carrier made of profile tube; 80 x 40 x 2 mm
  - 6 polyamide wheels D = 150 mm
  - Centre wheel pair elevated for tilting moment
  - Wheels heat-resistant up to 130 °C
  - With TARE sticker on both sides
- Dimensions: W: 1,015 x D: 1,000 x H: 1,950 mm

**TYPE WLW**

# Sausage cart

STAINLESS STEEL 1.4301



Sausage cart Type WLW-HS



Sausage cart Type WLW-RS

TYPE	LEVELS	OPTIMISED FOR CALIBRES	ARTICLE NO.
WLW-HS-V120 8E	8	D: 120 mm	40.00.00.82
WLW-HS-V140 8E	8	D: 140 mm	40.00.00.83

TYPE	LEVELS	OPTIMISED FOR CALIBRES	ARTICLE NO.
WLW-RS-V120 10E	10	D: 120 mm	40.00.00.84
WLW-RS-V120 11E	11	D: 120 mm	40.00.00.85
WLW-RS-V140 10E	10	D: 140 mm	40.00.00.86
WLW-RS-V140 11E	11	D: 140 mm	40.00.00.87

### SAUSAGE CART TYPE WLW-HS

- Firmly welded version
- Carrier made of profile tube 40 x 40 x 1.5 mm
- 8 shelves, shelf distance 220mm
- Distance from lowest level to floor is 320 mm
- Per level with 6 or 7 perforated half-shells
- Half shells with hole diameter D = 10 mm, Hole spacing 20 mm
- Undercarriage open, wheel carrier made of profile tube; 80 x 40 x 2 mm
- 6 polyamide wheels D = 150 mm
- Centre wheel pair elevated for tilting moment
- Wheels heat-resistant up to 130 °C Dimensions: W: 1,000 x D: 1,195 x H: 1,965 mm

### SAUSAGE CART TYPE WLW-RS

- Firmly welded version
- Carrier made of profile tube 40 x 40 x 2 mm
- Distance from lowest level to floor is 300 mm
- Shelves made of round steel D = 10 mm
- Distance between the steels 70 or 75 mm each, suitable for calibre D = 120 or 140 mm
- With 2 handles per side
- Undercarriage open, wheel carrier made of profile tube; 80 x 40 x 2 mm
- 6 polyamide wheels D = 200 mm
- Centre wheel pair elevated for tilting moment
- Wheels heat-resistant up to 130 °C Dimensions: W: 930 x D: 1,110 x H: 1,990 mm

# ENQUIRY FORM SMOKE TROLLEY

## 1 SMOKE TROLLEY VERSION



Smoke trolley **H-shape**



Smoke trolley **Z-shape**



Smoke trolley **M-shape**

## 2 LAYER TYPE

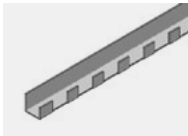

Layer type **1**



Layer type **2**

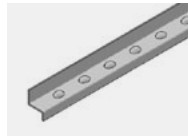

Layer type **3**

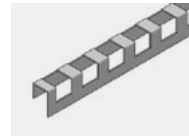

Layer type **4**

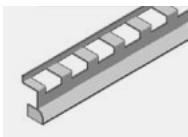

Layer type **5**

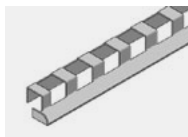

Layer type **6**

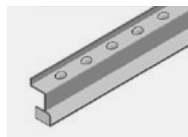

Layer type **7**

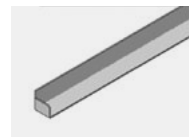

Layer type **8**

We manufacture all smoke trolleys according to your wishes!

- Complete the enquiry form in full
- Fax or scan the enquiry form and send by e-mail:

**F** +49 (0) 23 54.94 45-299

**E** info@mohn-gmbh.com

## 3 SMOKE TROLLEY DIMENSIONS

Width:  mm

Depth:  mm

Height:  mm

## 4 SMOKE STICK LENGTH

900  1000  mm

## 5 DIMENSIONS FOR LGRID FRAME

Width:  mm

Depth:  mm

Height:  mm

## 6 LOAD PER GRID FRAME

max.  kg

## 7 NUMBER OF SHELVES

Pc.

## 8 SHELF SPACING

mm

## 9 SMOKE TROLLEY TOTAL LOAD

max.  kg

## 10 TEMPERATURE RANGE

°C | Max. Period  Min.

## 11 OPTIONS

Push handles:  2  4

Tara note:  top  below

Others:

### COMPANY

### NAME

### TELEPHONE

### E-MAIL



**TYPE HBW**

# Lift and feed trolleys

STAINLESS STEEL 1.4301



Type HBW-S 200



Type HBW-S 300/2

TYPE	VERSION	VOLUME in ltr	DIMENSIONS W x D x H in mm	ARTICLE NO.
HBW-S 120	unperforated	120	625 x 600 x 595	41.00.00.01
HBW-S 200	unperforated	200	720 x 780 x 700	41.00.00.00
HBW-S 200/2	unperforated / 2-split	200	680 x 685/780 x 700	41.00.00.03
HBW-L 200	unperforated - noise-reduced	200	720 x 780 x 700	41.00.00.14
HBW-G 200	perforated (Diam.: 10 mm; D: 20 mm)	200	720 x 780 x 700	41.00.00.04
HBW-S 300	unperforated	300	720 x 780 x 950	41.00.00.06
HBW-S 300/2	unperforated / 2-split	300	680 x 685/780 x 950	41.00.00.13
HBW-L 300	unperforated - noise-reduced	300	720 x 780 x 950	41.00.00.19
HBW-G 300	perforated (Diam.: 10 mm; D: 20 mm)	300	720 x 780 x 950	41.00.00.11



Type HBW-G 200



Type HBW-L 200

**OPTIONS FOR HBW-X 200 + 300**

One-way covers made of fleece	Article no. 99.90.00.01
Cover Ecoline [corners square]	Article no. 41.00.00.05
Cover Highline [rounded corners]	Article no. 41.00.00.29
Cover highline [2-part, foldable]	Article no. 41.00.00.16
ERGO push handle	Article no. 16.00.00.18
Strainer insert [perforated, with 4 feet 100 mm]	Article no. 41.00.00.31
Shim valve (DN 50)	Article no. 99.80.01.65
Milk screw cap (DN 50)	Article no. 15.00.00.09
Cover storage cart [capacity: 10 pieces]	Article no. 41.00.00.30
Cleaning rack	Article no. 41.00.00.12

**OPTIONS FOR HBW-S 120**

Cover Highline	Article no. 41.00.00.02
Cleaning rack	Article no. 41.00.00.26

- Circumferentially welded beaded edge
- Wall thickness 2 mm + 3 mm bottom plate
- Two-sided lifting clamps
- Polyamide wheels, D: 150 mm with tilting moment
- With dump lip

**TYPE RS**

# Smoking skewers

STAINLESS STEEL 1.4301

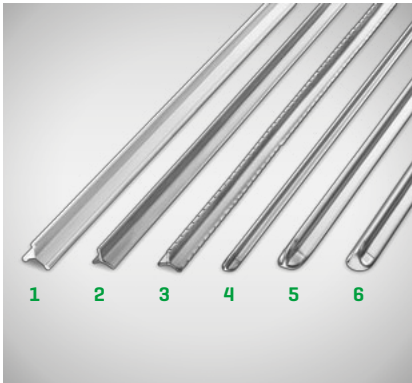

- 1 Aluminium
- 2 Stainless steel
- 3 Stainless steel notched
- 4 HD stainless steel slim
- 5 HD stainless steel standard
- 6 HD stainless steel flat

TYPE	LENGTH / VERSION	MATERIAL	ARTICLE NO.
RS-A	900 mm	Aluminium	40.00.01.01
RS-A	1,000 mm	Aluminium	40.00.01.00
RS-E	900 mm	Stainless steel	40.00.01.15
RS-E	900 mm, notched	Stainless steel	40.00.01.44
RS-E	1,000 mm	Stainless steel	40.00.01.05
RS-E	1,000 mm, notched	Stainless steel	40.00.01.45
RS-E	1,000 mm, with 5 hooks	Stainless steel	40.00.01.06
RS-HD1	900 mm, flat	Stainless steel	40.00.01.59
RS-HD1	1,000 mm, flat	Stainless steel	40.00.01.42
RS-HD2	900 mm, standard	Stainless steel	40.00.01.60
RS-HD2	1,000 mm, standard	Stainless steel	40.00.01.48
RS-HD3	900 mm, slim	Stainless steel	40.00.01.61
RS-HD3	1,000 mm, slim	Stainless steel	40.00.01.47

**TYPE RSW**

# Smoke stick trolley

STAINLESS STEEL 1.4301



Type RSW-G



Type RSW-K



Type RSW-C (smoke stick caddy)

TYPE	VERSION in mm	DIMENSIONS W x D x H in mm	ARTICLE NO.
RSW-K	approx. 400 pieces standing	400 x 600 x 710	40.00.00.08
RSW-G	approx. 800 pieces lying	600 x 900 x 800	40.00.00.18
RSW-C	approx. 250 pieces standing	800 x 450 x 1050	49.00.00.82

**TYPE GS-V**

## Grid frames

STAINLESS STEEL 1.4301

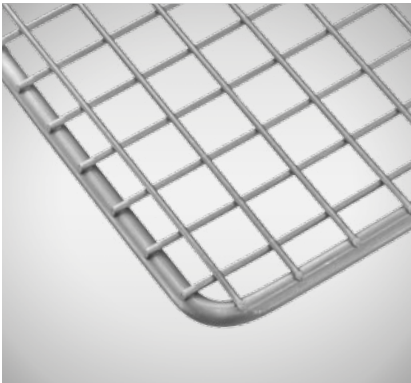

Grid frame Type GS-V

TYPE	VERSION in mm	DIMENSIONS W x D x H in mm	ARTICLE NO.
GS-V 940/990	Round steel; MW: 40 x 40 x 3	940 x 990 x 13	90.00.01.20
GS-V-G 940/990	Round steel with handrail; MW: 40 x 40 x 3	940 x 990 x 50	90.00.01.21
GS-V-LP 940/990	Angled frame 40 x 40 x 3; MW: 40 x 40 x 3	940 x 990 x 40	90.00.01.22
GS-V-RS 940/990	Web grate, D: 10; division: 50	940 x 990 x 10	90.00.01.23

**TYPE BS**

## Sheet metal frame

STAINLESS STEEL 1.4301



Sheet metal frame, unperforated, Type BS-GU

- Load capacity and dimensions as required
- 40 mm all-round upstand (or on request)
- Carrying handles, height with handles approx. 100 mm (or on request)
- Perforated or unperforated base

TYPE	VERSION	DIMENSIONS W x D x H in mm	ARTICLE NO.
BS-KU	small, unperforated	890 x 430 x 40/100	40.00.00.23
BS-GU	large, unperforated	990 x 430 x 40/100	40.00.00.24
BS-KG	small, perforated	890 x 430 x 40/100	40.00.00.21
BS-GG	large, perforated	990 x 430 x 40/100	40.00.00.22



Sheet metal frame, perforated, Type BS-KG

## Grid frames for cooking and smoking trolleys

---

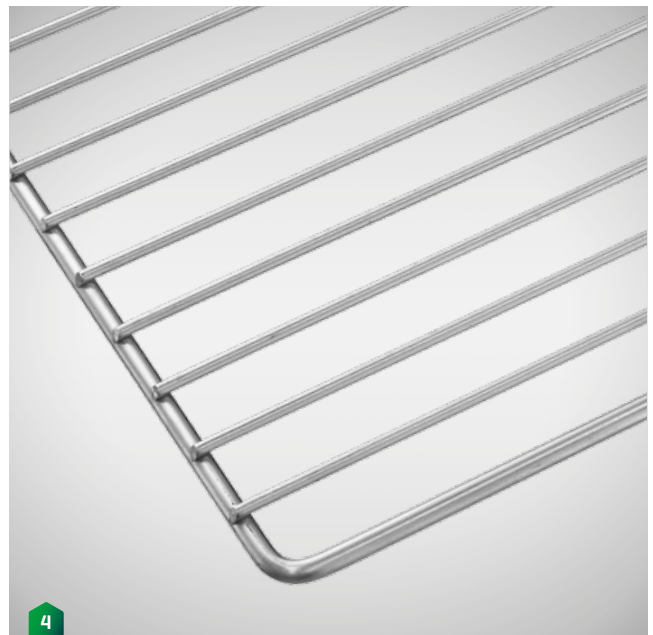
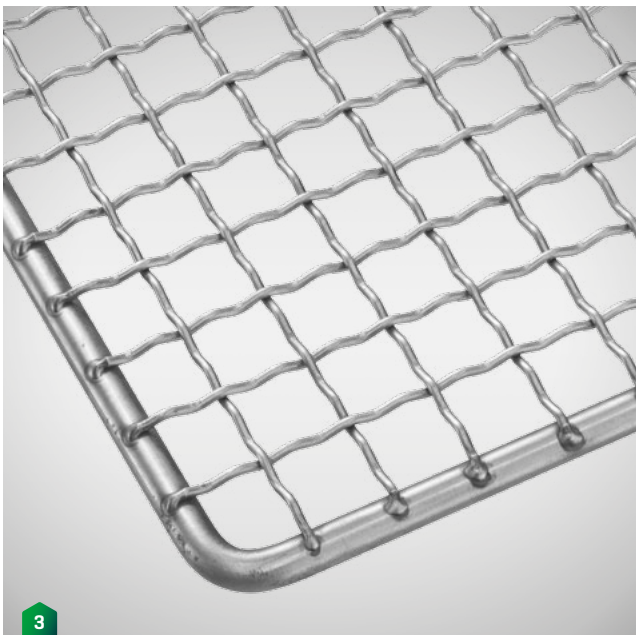
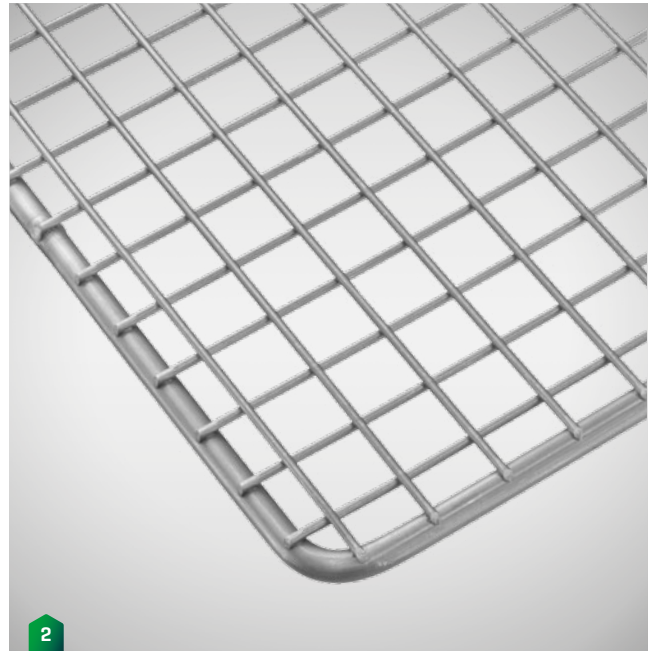

- 1 Pressing grid
- 2 Welding grid
- 3 Wave mesh
- 4 Web grate

**TYPE GS-V**

**Grid frames**

STAINLESS STEEL 1.4301 (V4A ON REQUEST)

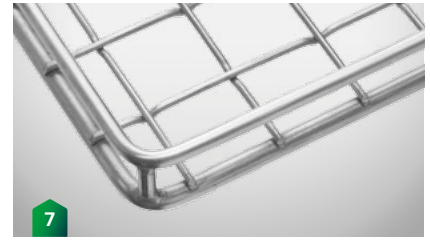
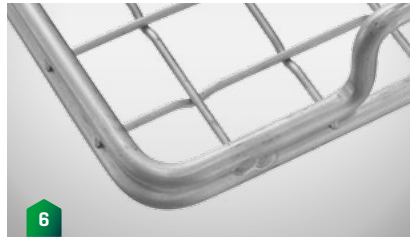
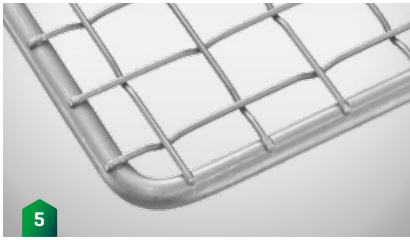

- Standard versions that can be customised to meet special requirements
- All dimensions are manufactured according to customer specifications
- Durable and functional
- Optimal air circulation for product support

**THE MOHN ADVANTAGES**

- Large selection of different versions
- Permanently welded wire mesh and frame
- Sturdy and first-class stained
- Surfaces electropolished or Teflon-coated on request
- Pressing grid: smooth surface for optimum product support
- Stackable grating with trolley feet for, e.g., cheese, meatloaf available on request

We manufacture all products according to your wishes.

- 5 Single frame
- 6 Double frame
- 7 Handrail frame

# ENQUIRY FORM GRATINGS PART 1/2

## 1 WIRE MESH GRATING VERSION

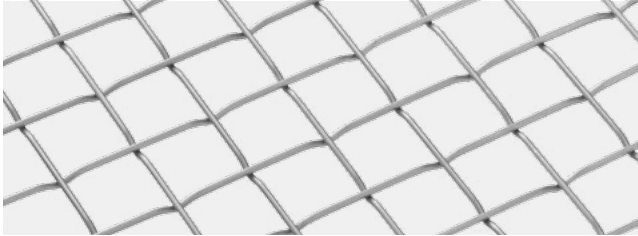

Pressing grid

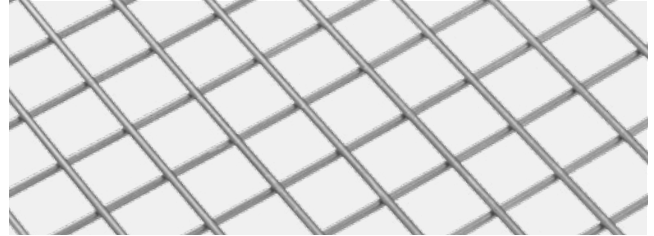

Welding grid

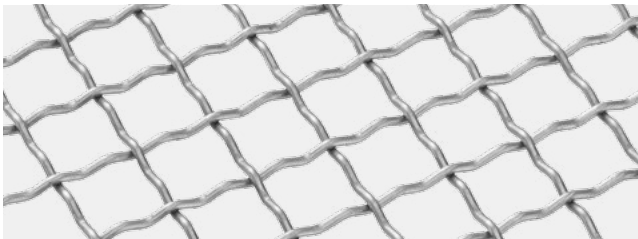

Wave mesh

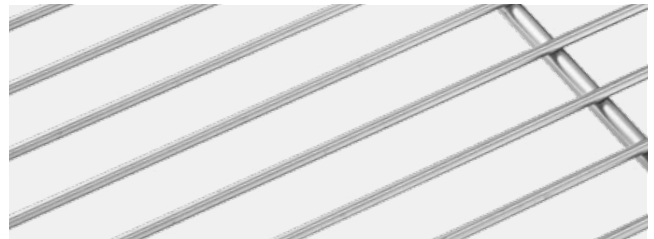

Web grate

## 2 FRAME VERSION

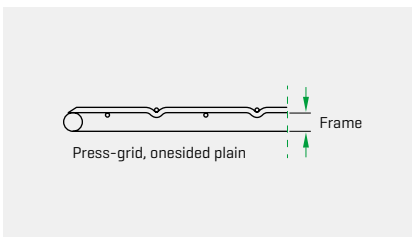
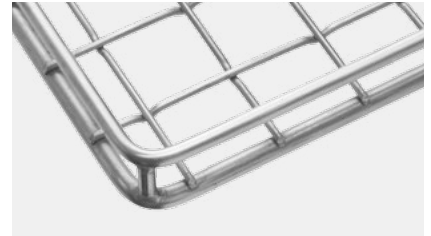

Single frame

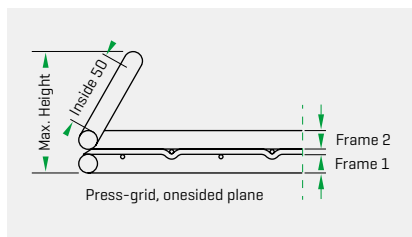

Double frame

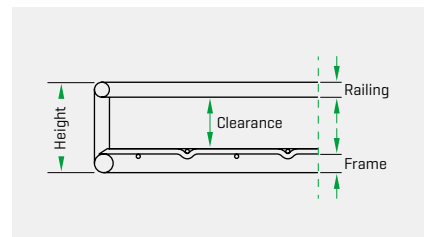

Handrail frame

## ENQUIRY FORM GRATINGS PART 2/2

### 3 DIMENSIONS

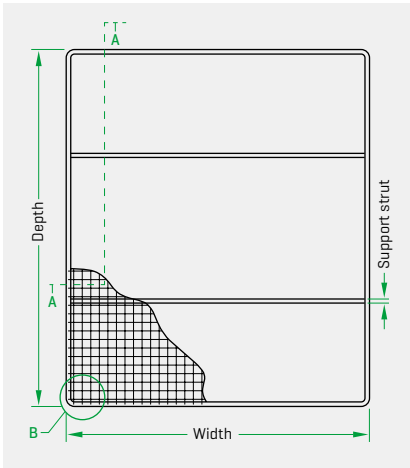

Width: \_\_\_\_\_ mm

Depth: \_\_\_\_\_ mm

Height: \_\_\_\_\_ mm

∅ Frame 1: \_\_\_\_\_ mm

∅ Frame 2 (for double f.): \_\_\_\_\_ mm

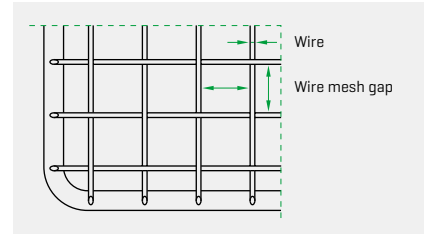

Mesh size: \_\_\_\_\_ x \_\_\_\_\_ mm

∅ wire: \_\_\_\_\_ mm

### 4 LOAD

\_\_\_\_\_ kg

The number of support struts is adapted to the load!

### 5 HANDLES

without handles  with handles

Handles:  vertical  60° inwards

### 6 HANDRAIL

2-sided  circumferential

Height: \_\_\_\_\_ mm

Clear dimension: \_\_\_\_\_ mm

### 7 PRODUCTS\*

\_\_\_\_\_

\*e.g. fish, ham, cheese, etc.

We manufacture all gratings according to your wishes.

- Complete the enquiry form in full
- Fax or scan the enquiry form and send by e-mail:

F +49 (0) 23 54.94 45-299

E [info@mohn-gmbh.com](mailto:info@mohn-gmbh.com)

### 8 STACKING SOLUTIONS (FOR CHEESE PRODUCTION)

Stacking height: \_\_\_\_\_ mm

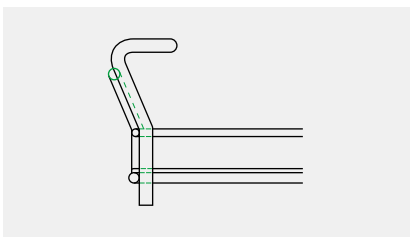

Stacking foot 1

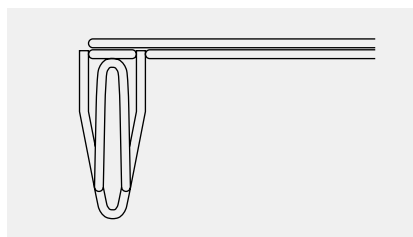

Stacking foot 2

#### COMPANY

#### NAME

#### TELEPHONE

#### E-MAIL



# ENQUIRY FORM WIRE MESH BASKETS

## 1 DIMENSIONS

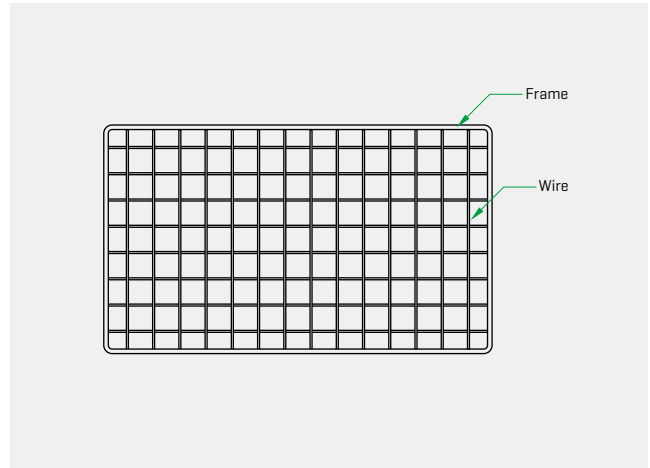
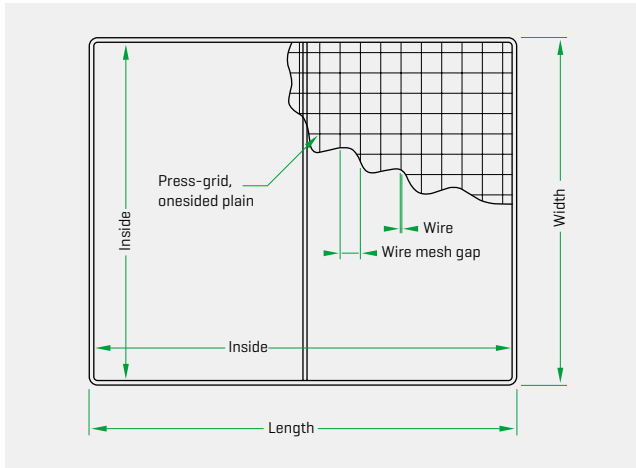

Length: _____ mm	Mesh size:     x     mm	Max. Height (stackable version): _____ mm
Width: _____ mm	∅ Frame*: _____ mm	<input type="checkbox"/> stackable (only possible without handles)
Height: _____ mm	∅ Wire* (bottom): _____ mm	<i>* is adapted to the load</i>

## 2 BASKETS

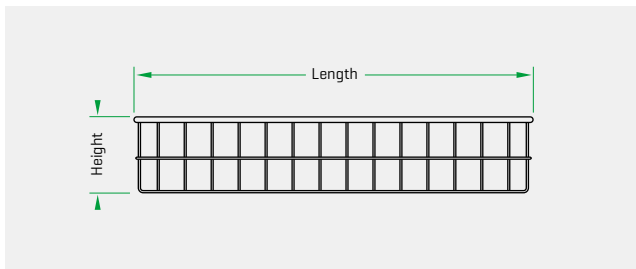

Basket standard

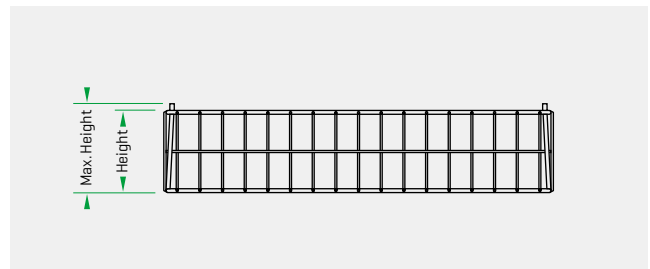

Basket with stacking corners

## 3 LOAD

Load per basket: _____ kg
Stacking load: _____ kg

We manufacture all wire mesh baskets according to your wishes.

## 4 HANDLES

without handles     with handles

Handles:     vertical     60° inwards

- Complete the enquiry form in full
- Fax or scan the enquiry form and send by e-mail:

**F** +49 (0) 23 54.94 45-299  
**E** info@mohn-gmbh.com

**COMPANY**

**NAME**

**TELEPHONE**

**E-MAIL**

**TYPE RSK, RPK**

**Wire mesh baskets**

STAINLESS STEEL 1.4301



Mesh basket



Mesh basket, stackable



Mesh basket, round

**FOR SMOKING, PASTEURISING, COOKING, DEFROSTING, ETC.**

- Durable and functional
- High stability with low dead weight
- First-class stained, electropolished on request or Teflon coated
- With or without stacking function
- With or without handles

**PRESSING GRID**

- Smooth surface on one side
- Interlacing ensures high stability

Dimensions as desired by the customer!

# ENQUIRY FORM PASTEURISATION AND DRIP-OFF GRID

## 1 SPACE DIVISION OF THE COVER GRID

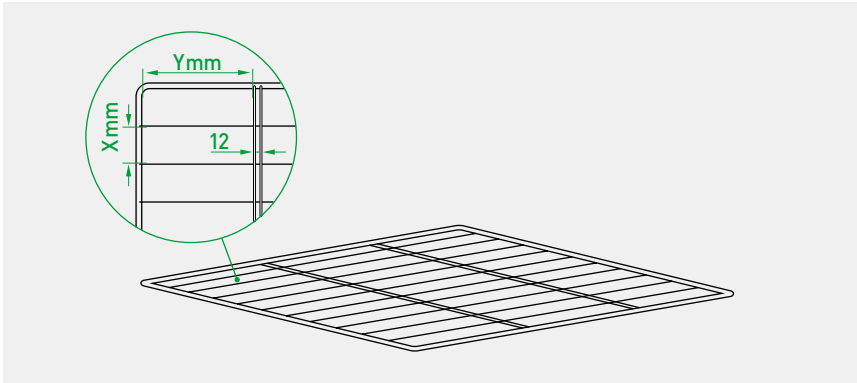

X \_\_\_\_\_ x Y \_\_\_\_\_ mm

Others: \_\_\_\_\_

\_\_\_\_\_

\_\_\_\_\_

\_\_\_\_\_

## 2 DIMENSIONS OF THE PASTEURISATION AND DRIP-OFF GRID

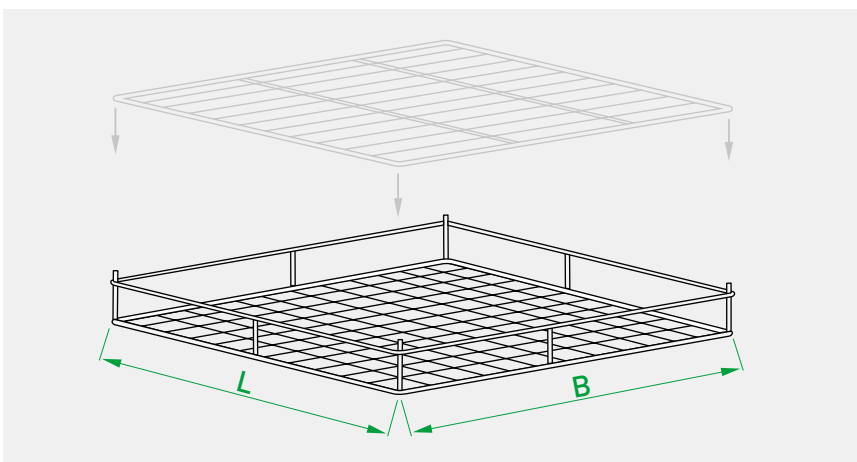

Length: \_\_\_\_\_ mm

Width: \_\_\_\_\_ mm

Others: \_\_\_\_\_

\_\_\_\_\_

\_\_\_\_\_

\_\_\_\_\_

## 3 SIZE OF YOUR PRODUCT PACKAGING

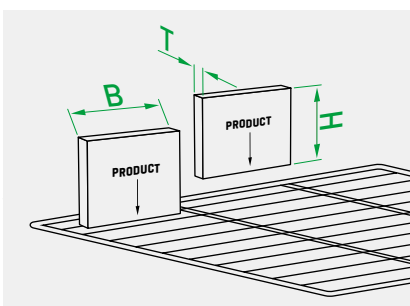

Width: \_\_\_\_\_ mm

Depth: \_\_\_\_\_ mm

Height: \_\_\_\_\_ mm

## 4 PRODUCT WEIGHT

\_\_\_\_\_ kg

We manufacture all grids according to your wishes.

- Complete the enquiry form in full
- Fax or scan the enquiry form and send by e-mail:

**F** +49 [0] 23 54.94 45-299

**E** info@mohn-gmbh.com

**COMPANY**

\_\_\_\_\_

**NAME**

\_\_\_\_\_

**TELEPHONE**

\_\_\_\_\_

**E-MAIL**

\_\_\_\_\_

**TYPE RPF 4**

## Pasteurisation and drip-off grid

STAINLESS STEEL 1.4301



- Stable and hygienic
- First-class staining
- Quick draining after pasteurisation
- Versatile and customisable

Dimensions as desired  
by the customer!

6

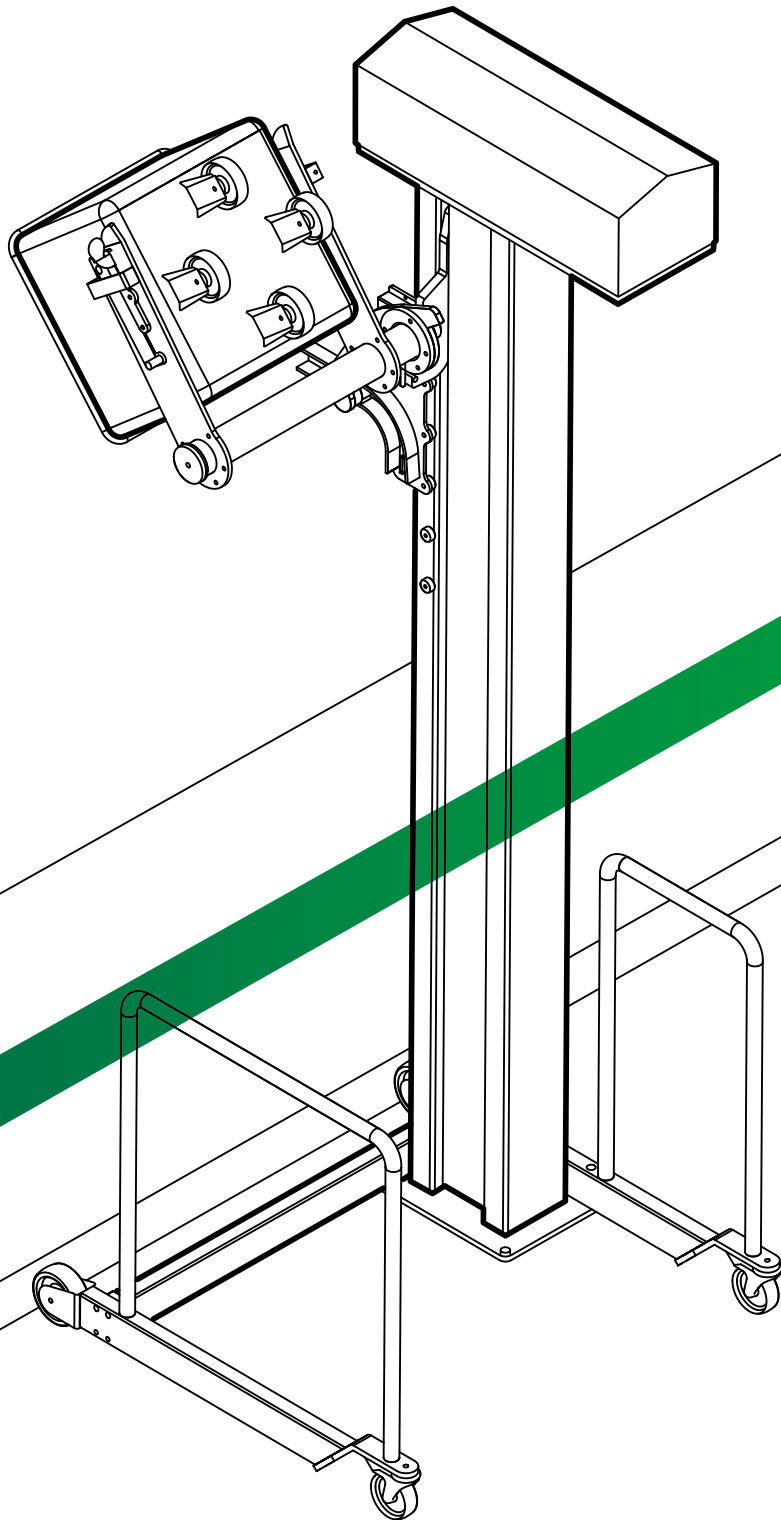

# 06

## Further product range

Containers and transport equipment

---

Pallet truck

---

Swing loader

---

Lift-tilting devices

---

Drainage Technology

---

Wall skirting protection

---

Swing doors

---

**TYPE ESTB-OG**

## Euro containers without gradient



- Euro containers with straight base
- Very robust, in 3 different versions
- Stackable industrial version
- Robust stacking corners
- Sturdy welded construction made from tubular frame profile
- Retractable on four sides
- Load bearing capacity: 1,000 kg

TYPE	VERSION	CONTAINER INTERIOR HEIGHT	VOLUME in ltr	DIMENSIONS L x W x H in mm	ARTICLE NO.
ESTB-OG 490 F	Feet	608 mm	appr. 490	1200 x 800 x 760	49.00.02.35
ESTB-OG 490 K	Skids	608 mm	appr. 490	1200 x 800 x 760	49.00.02.36
ESTB-OG 600 F	Feet	608 mm	appr. 600	1200 x 1000 x 760	49.00.02.39
ESTB-OG 600 K	Skids	608 mm	appr. 600	1200 x 1000 x 760	49.00.02.40

**TYPE ESTB-MG 490 / 600**

## Euro containers with gradient

STAINLESS STEEL 1.4301



- Euro stacking container, base with 2 % incline [outlet optionally available]
- Very robust design for forklift traffic
- retractable on 4 sides
- Various volumes available
- Version with 2 runners or robust stacking feet
- Hygienic stacking corners
- Wall thickness 2 mm

TYPE	VERSION	CONTAINER INTERIOR HEIGHT	VOLUME in ltr	DIMENSIONS L x W x H in mm	ARTICLE NO.
ESTB-MG 490 F	Feet	608 mm	appr. 490	1200 x 800 x 760	49.00.02.37
ESTB-MG 490 K	Skids	608 mm	appr. 490	1200 x 800 x 760	49.00.02.38
ESTB-MG 600 F	Feet	608 mm	appr. 600	1200 x 1000 x 760	49.00.02.41
ESTB-MG 600 K	Skids	608 mm	appr. 600	1200 x 1000 x 760	49.00.02.42

**TYPE ESTB-MG 350 / 450**

## Euro containers with steep gradient

STAINLESS STEEL 1.4301



- Euro containers, with steep incline
- Base incl. ball valve
- Robust industrial version
- Container with all-round tightly welded beaded edge
- Stacking feet with reinforcement plate
- Wall thickness 2 mm
- Spout with screw cap

TYPE	VERSION	CONTAINER INTERIOR HEIGHT	VOLUME in ltr	DIMENSIONS L x W x H in mm	ARTICLE NO.
ESTB-MG 350 F	Feet	360/560 mm	appr. 350	1200 x 800 x 760	49.00.02.31
ESTB-MG 350 K	Skids	360/560 mm	appr. 350	1200 x 800 x 760	49.00.02.32
ESTB-MG 450 F	Feet	360/560 mm	appr. 450	1200 x 1000 x 760	49.00.02.33
ESTB-MG 450 K	Skids	360/560 mm	appr. 450	1200 x 1000 x 760	49.00.02.34



**OPTIONS FOR ALL TYPES ESTB**

Cover for Euro container D-ESTB 600	Article no. 49.00.01.48
Cover for Euro containers, D-ESTB 350 to 490	Article no. 49.00.01.49
Milk screw cap DN 50	Article no. 15.00.00.09
Shim valve outlet	Article no. 99.80.01.65
Ball valve	Article no. 99.90.00.21
Stainless steel etching [H: 75 mm] per number or letter	Article no. 90.00.00.91

**TYPE STB-H**

## Stacking container Highline



- Highly hygienic stack corners recessed into the legs protect the contents of the containers from contamination
- Robust stacking feet made from 3 mm thick walls and a 6 mm thick base plate
- Various versions and volumes available
- Container wall thickness 2 mm
- 4-sided retractable stacking containers
- Type STB-H-MB with 2 % gradient in the tank base are prepared for the installation of an optionally available milk screw cap, ball valve or disc valve
- Type STB-H-MB with steeply sloping tank bottom are equipped with ball valve DN 50



TYPE	VERSION	CONTAINER INTERIOR HEIGHT	VOLUME in ltr	DIMENSIONS L x W x H in mm	ARTICLE NO.
STB-H-MG 350 F	steep gradient	360 - 560 mm	appr. 350	1200 x 800 x 760	49.00.04.01
STB-H-MG 450 F	steep gradient	360 - 560 mm	appr. 450	1200 x 1000 x 760	49.00.04.02
STB-H-MG 490 F	2 % gradient	608 mm	appr. 490	1200 x 800 x 760	49.00.04.03
STB-H-MG 600 F	2 % gradient	608 mm	appr. 600	1200 x 1000 x 760	49.00.04.04
STB-H-OG 490 F	without gradient	608 mm	appr. 490	1200 x 800 x 760	49.00.04.05
STB-H-OG 600 F	without gradient	608 mm	appr. 600	1200 x 1000 x 760	49.00.04.06

**TYPE WW-R**

# Tub trolley

STAINLESS STEEL 1.4301



- Very robust design, wall thickness 2 mm
- Container with all-round tightly welded beaded edge
- Rounded corners, no dirty corners
- Tub size: W: 610 x D: 970 x H: 290 mm
- Push handle made of round steel
- 2 rigid casters + 2 swivel casters made of polyamide, Ø 150 mm
- Swivel casters without brakeslocking mechanism

TYPE	VOLUME in ltr	DIMENSIONS W x D x H in mm	ARTICLE NO.
WW-R	150	670 x 1030 x 840	43.00.00.17

**OPTIONS**

Outlet screw cap [DN 40]	99.80.01.26
Swivel casters with locking mechanism	43.00.00.98
Highline cover for WW-R [rounded corners]	49.00.00.94
Ecoline cover for WW-R [right-angled corners]	49.00.00.90
Ecoline cover, hinged for WW-R	49.00.00.91
Highline cover, hinged for WW-R	49.00.00.92

**TYPE KB**

## Cooling container

STAINLESS STEEL 1.4301



Type KB 300

- Robust industrial version
- 3 different capacities available
- Container with all-round tightly welded beaded edge
- Wall thickness 2 mm, reinforced base plate
- Front outlet with screw cap
- 4 polyamide wheels, Ø 150 mm, centre pair of wheels raised

TYPE	CONTAINER DEPTH	VOLUME in ltr	DIMENSIONS W x D x H in mm	ARTICLE NO.
KB 200	510 mm	200	680 x 750 x 700	49.00.01.01
KB 300	490 mm	300	690 x 990 x 680	49.00.01.02
KB 400	490 mm	400	950 x 1040 x 680	49.00.01.03

**OPTIONS**

Overflow standpipe valve	on request
--------------------------	------------

**TYPE TM**

## Transport trough

STAINLESS STEEL 1.4301



- Very robust industrial design
- Tightly welded beaded edge all round
- Push handle on straight end face
- Front outlet with screw cap
- Choice of 500 or 800 litre volume
- Robust construction: Wall thickness 2 mm
- 4 polyamide wheels, Ø 200/300 mm
- Centre wheel pair elevated
- Trough height: 428 mm

TYPE	VOLUME in ltr	DIMENSIONS W x D x H in mm	ARTICLE NO.
TM 500	500	910 x 1850 x 750	49.00.01.00
TM 800	800	1010 x 2050 x 780	49.00.01.09

**TYPE KM**

## Ball trough

STAINLESS STEEL 1.4301



- The robust half-ball trough with a volume of 70 litres
- Tightly welded beaded edge all round
- Available in 2 heights
- Push handle made of round steel
- 2 rigid casters, Ø 125 mm and stand
- Clear trough Ø 650 mm
- Trough depth 340 mm

TYPE	VOLUME in ltr	DIAMETER in mm	DIMENSIONS W x D x H in mm	ARTICLE NO.
KM 70/800	70	710	800	49.00.09.12
KM 70/1000	70	710	1000	49.00.09.92

**TYPE MM-150**

## Mixing trough

STAINLESS STEEL 1.4301



- Robust industrial design with 150 litre volume
- Tightly welded beaded edge all round
- Push handle on straight end face
- Front outlet with screw cap
- 2 rigid casters and 2 swivel casters with locking mechanism, Ø 125 mm [Type MM 150-F]
- 2 rigid casters and 2 stands [Type MM 150-S]
- Trough depth: 300 mm

TYPE	VERSION	VOLUME in ltr	DIMENSIONS W x D x H in mm	ARTICLE NO.
MM 150-F	2 rigid, 2 swivel*	150	655 x 1110 x 835	49.00.00.80
MM 150-S	2 rigid, 2 stand*	150	655 x 1110 x 835	49.00.09.29

\*rigid = rigid caster, swivel = swivel caster, Stand = stand foot

**TYPE MM-200**

## Mixing trough

STAINLESS STEEL 1.4301



- Robust industrial version with 200 litre volume
- Tightly welded beaded edge all round
- Push handle on straight end face
- Front outlet with screw cap
- 2 rigid casters and 2 swivel casters with locking mechanism, Ø 125 mm
- Trough depth: 300 mm

TYPE	VERSION	VOLUME in ltr	DIMENSIONS W x D x H in mm	ARTICLE NO.
MM 200	2 rigid, 2 swivel*	200	655 x 1500 x 835	49.00.00.81

\*rigid = rigid caster, swivel = swivel caster, Stand = stand foot

**TYPE MM-300**

## Mixing trough

STAINLESS STEEL 1.4301



- Robust industrial version with 300 litre volume
- Tightly welded beaded edge all round
- Push handle on straight end face
- Front outlet with screw cap
- 2 rigid casters and 2 swivel casters with locking mechanism, Ø 125 mm
- Trough depth: 300 mm

TYPE	VERSION	VOLUME in ltr	DIMENSIONS W x D x H in mm	ARTICLE NO.
MM 300	2 rigid, 2 swivel*	300	655 x 1860 x 835	49.00.00.83

\*rigid = rigid caster, swivel = swivel caster, Stand = stand foot

**OPTIONS FOR ALL TYPES MM**

Rounded end faces	on request
Ball valve (DN 40)	Article no. 99.90.00.21
Highline cover for MM-150 (rounded corners)	Article no. 49.00.01.45
Ecoline cover for MM-150 (right-angled corners)	Article no. 49.00.01.65
Highline cover for MM-200 (rounded corners)	Article no. 49.00.01.46
Ecoline cover for MM-200 (right-angled corners)	Article no. 49.00.01.66
Highline cover for MM-300 (rounded corners)	Article no. 49.00.01.47
Ecoline cover for MM-300 (right-angled corners)	Article no. 49.00.01.67

**TYPE STR-1**

**Trolley, load 250 kg**

STAINLESS STEEL 1.4301



- For the transport of Euro containers
- Wheel housing made of 1.25 mm stainless steel
- Stackable due to stacking trough
- Load bearing capacity 250 kg
- 6 polyamide wheels, Ø 125 mm
- Centre wheel pair elevated

TYPE	LOAD BEARING CAPACITY in kg	DIMENSIONS W x D x H in mm	ARTICLE NO.
STR-1	250	410 x 650 x 170	40.00.00.01

**OPTIONS**

Labelling up to max. 10 letters/numbers	Article no. 90.00.00.94
---	-------------------------

**TYPE SLR**

**Trolley, load 350 kg**

STAINLESS STEEL 1.4301



- For the transport of heavy Euro containers
- Wheel housing made of 2.0 mm stainless steel
- Stackable due to stacking trough
- Load bearing capacity 350 kg
- 6 polyamide wheels, Ø 125 mm
- Centre wheel pair elevated

TYPE	LOAD BEARING CAPACITY in kg	DIMENSIONS W x D x H in mm	ARTICLE NO.
SLR	350	410 x 650 x 170	40.00.00.02

**OPTIONS**

Labelling up to max. 10 letters/numbers	Article no. 90.00.00.94
---	-------------------------

**TYPE SGR**

## Trolley, load 200 kg, low-noise

STAINLESS STEEL 1.4301



- For low-noise transport of Euro containers
- Wheel housing made from 2 mm stainless steel sheet
- Stackable due to stacking trough
- Load bearing capacity 200 kg
- 6 abrasion-resistant solid rubber wheels, Ø 125 mm
- Centre wheel pair elevated

TYPE	LOAD BEARING CAPACITY in kg	DIMENSIONS W x D x H in mm	ARTICLE NO.
SGR	200	410 x 650 x 170	40.00.03.07

**OPTIONS**

Labelling up to max. 10 letters/numbers Article no. 90.00.00.94

**TYPE STR-D**

## Trolley, load 350 kg

STAINLESS STEEL 1.4301



- For the transport of Euro containers
- Wheel housing made of 1.25 mm stainless steel
- 2 containers can be transported next to each other
- Stackable due to stacking trough
- Load bearing capacity 350 kg
- 6 polyamide wheels, Ø 125 mm
- Centre wheel pair elevated

TYPE	LOAD BEARING CAPACITY in kg	DIMENSIONS W x D x H in mm	ARTICLE NO.
STR-D	350	620 x 880 x 170	40.00.00.61

**OPTIONS**

Labelling up to max. 10 letters/numbers Article no. 90.00.00.94



**TYPE KSR**

## Plastic trolley



- Ideal for use in shop areas due to its low weight
- 4 swivel casters with ball bearings and galvanised steel housing
- Quiet-running rubber wheels, Ø 100 mm
- Load capacity 250 kg
- Various colours

TYPE	COLOUR	LOAD BEARING CAPACITY	DIMENSIONS W x D x H in mm	ARTICLE NO.
KSR-B	Blue	250 kg*	620 x 410 x 150	40.00.00.54
KSR-W	White	250 kg*	620 x 410 x 150	40.00.00.55
KSR-GE	Yellow	250 kg*	620 x 410 x 150	40.00.00.56
KSR-O	Orange	250 kg*	620 x 410 x 150	40.00.00.57
KSR-R	Red	250 kg*	620 x 410 x 150	40.00.00.58
KSR-GR	Green	250 kg*	620 x 410 x 150	40.00.00.59

\*evenly distributed

**TYPE WRR**

## Stainless steel tractable trolley

STAINLESS STEEL 1.4301



- Robust angled frame dolly for Euro containers
- Trolley with all-round, solid angled frame (40 x 40 x S 3.0 mm)
- 4 swivel casters made of polyamide, Ø 125 mm
- Wheel housing made of stainless steel 1.4301
- Load capacity 300 kg (at uniform load distribution)
- For the transport of E1, E2 and E3 Euro containers

TYPE	LOAD BEARING CAPACITY in kg	DIMENSIONS W x D x H in mm	ARTICLE NO.
WRR	300*	620 x 410 x 150	40.00.00.09

\*evenly distributed

**TYPE RBR**

## Round container

STAINLESS STEEL 1.4301



- For transporting round containers or tonnes
- Stable round stainless steel frame
- Suitable for container diameters of 300 mm
- Load bearing capacity 250 kg
- 4 swivel casters made of polyamide, Ø 50 mm
- 1 swivel caster with locking mechanism

TYPE	FRAME HEIGHT in mm	LOAD BEARING CAPACITY	DIAMETER in mm	ARTICLE NO.
RBR	120	250 kg*	340	20.00.00.10

\*evenly distributed

**TYPE ROS**

## Trolley collector

STAINLESS STEEL 1.4301



- For more order and space in the fleet
- Sturdy, welded stainless steel construction
- Easily stacks up to 10 standard trolleys
- Stacking trough in wheel carrier
- 6 polyamide wheels, Ø 125 mm
- Tilting moment, therefore rotatable on the spot

TYPE	CAPACITY	DIMENSIONS W x D x H in mm	ARTICLE NO.
ROS	10 trolleys	410 x 655 x 1375	45.00.03.55

**TYPE FKR-E**

## Barrel trolley

STAINLESS STEEL 1.4301



- Suitable for use in wet areas
- 99 % of commercially available barrels can be transported without any problems
- Welded stainless steel construction
- Adjustable barrel lock
- 2 safety handles
- 2 solid rubber wheels, wheel hubs with roller bearings
- Load capacity 250 kg

TYPE	VERSION	DIMENSIONS W x D x H in mm	ARTICLE NO.
FKR-E	Stainless steel	610 x 300 x ~1,400	49.00.09.71

**TYPE FLR-E**

## Bottle trolley

STAINLESS STEEL 1.4301



- Suitable for use in cleanrooms and wet rooms
- For gas cylinders 10 - 40 litres. Contents (Ø 140 - 250 mm)
- Bottle holder with safety chain
- Load capacity: 100 kg
- 2 polyurethane tyred polyamide wheels (plain bearings), Ø 250 mm

TYPE	VERSION	DIMENSIONS W x D x H in mm	ARTICLE NO.
FLR-E	100	430 x 220 x 1200	40.00.03.12

**TYPE SK-E VG**

## Sack truck

STAINLESS STEEL 1.4301



- Suitable for use in wet operations
- With mudguards and safety handles
- Blade width: 300 mm, blade depth: 300 mm
- Blade thickness: 4 mm
- 2 wheels with pneumatic tyres and roller bearings, Ø 260 x 85 mm
- Load capacity: 150 kg
- Own weight 8 kg

TYPE	VERSION	DIMENSIONS	ARTICLE NO.
		W x D x H in mm	
SK-E VG	Stainless steel	1170 x 300/505 x 300	49.00.09.21

**TYPE GFL**

## Gas cylinder storage cabinet

STAINLESS STEEL 1.4301



**Stable, welded industrial version!**

- Pitched roof, 200 mm higher at the back in Hygienic-Design
- Above the door: closed area for labelling or marking (H: 150 mm)
- Door and side panels made of perforated sheet metal
- Pitched roof and rear wall made of closed sheet metal
- Door lockable by means of T-handle incl. profile cylinder lock and Bar locking
- Floor shelf + intermediate shelf firmly welded  
[load: 100 kg = 4 bottles]
- 4 height-adjustable PVC screw feet (+/- 30 mm)
- Standard ground clearance: 150 mm

TYPE	DIMENSIONS	CLEAR DIMENSION per shelf	ARTICLE NO.
	W x D x H in mm		
GFL	710 x 715 x 1720/1920	650 x 650 x 650	44.20.09.04

**TYPE SW HIGHLINE**

## Serving trolley Highline



Type SW 10/6-3

- Our permanently welded Highline version
- First-class workmanship for a long service life
- Shelves with all-round, raised profile edge
- Shelves neatly welded to tubular frame
- Sound-absorbing anti-drumming mat under each shelf
- 4 swivel casters with impact protection, Ø 125 mm, 2 with locking mechanism
- Shelves with rolled edges, ADVANTAGE: Protection against injuries

**OPTIONS**

Gusset plates for maximum stability	on request
Ergonomic push handle	on request

TYPE	SHELF	SHELF DIMENSION in mm	SHELF SPACING in mm	DIMENSIONS W x D x H in mm	ARTICLE NO.
SW 6/4-2	2	600 x 400	585	700 x 500 x 950	43.00.01.00
SW 6/4-3	3	600 x 400	275	700 x 500 x 950	43.00.01.01
SW 8/5-2	2	800 x 500	585	900 x 600 x 950	43.00.01.02
SW 8/5-3	3	800 x 500	275	900 x 600 x 950	43.00.01.03
SW 8/5-4	4	800 x 500	285	900 x 600 x 1290	43.00.01.04
SW 8/5-5	5	800 x 500	205	900 x 600 x 1290	43.00.01.05
SW 9/5-2	2	900 x 550	585	1000 x 650 x 950	43.00.01.06
SW 9/5-3	3	900 x 550	275	1000 x 650 x 950	43.00.01.07
SW 9/5-4	4	900 x 550	285	1000 x 650 x 1290	43.00.01.08
SW 9/5-5	5	900 x 550	205	1000 x 650 x 1290	43.00.01.09
SW 10/6-2	2	1000 x 600	585	1100 x 700 x 1000	43.00.01.10
SW 10/6-3	3	1000 x 600	275	1100 x 700 x 1000	43.00.01.11
SW 10/6-4	4	1000 x 600	285	1100 x 700 x 1340	43.00.01.12
SW 10/6-5	5	1000 x 600	205	1100 x 700 x 1340	43.00.01.13

**TYPE SW ECOLINE**

## Serving trolley Ecoline

STAINLESS STEEL 1.4301



Type SW 8/5-2-z

- Our demountable Ecoline version
- Demountable serving trolley
- 3 different versions
- Optionally with 2 shelves or 3 shelves
- Shelf spacing 262 or 565 mm
- Shelves with all-round, raised profile edge
- Sound-absorbing anti-drumming mat under each shelf
- 4 polyamide swivel casters Ø 125 mm, 2 with locking mechanism

TYPE	LOAD BEARING CAPACITY	SHELF	SHELF DIMENSION in mm	SHELF SPACING in mm	DIMENSIONS W x D x H in mm	ARTICLE NO.
SW 6/4-2-z	120 kg	2	630 x 400	565	700 x 475 x 970	43.00.02.00
SW 6/4-3-z	150 kg	3	630 x 400	262	700 x 475 x 970	43.00.02.01
SW 8/5-2-z	120 kg	2	800 x 500	565	870 x 575 x 970	43.00.02.02
SW 8/5-3-z	150 kg	3	800 x 500	262	870 x 575 x 970	43.00.02.03
SW 10/6-2-z	120 kg	2	1000 x 600	565	1070 x 675 x 970	43.00.02.04
SW 10/6-3-z	150 kg	3	1000 x 600	262	1070 x 675 x 970	43.00.02.05

**TYPE TWPE**

## Plates transport trolley

STAINLESS STEEL 1.4301



- For transporting and storing plastic cutting plates
- Base frame made of rectangular tube, 40 x 80 x 2 mm,
- 4 longitudinally welded round tubes, Ø 25 mm
- Frame construction made of square tube 30 x 30 x 1.50 mm
- Compartment partition made of square tube, 20 x 20 x 1.50 mm
- with welded-in round rod made of solid material, Ø 10 mm
- Front with push handle made of round tube, Ø 25 mm
- 2 swivel casters with locking mechanism and 2 rigid casters, stainless steel wheel housing
- Polyamide wheels, white, wheel Ø 125 mm

TYPE	CAPACITY Cutting plates	CLEAR SHELF MEASURE	DIMENSIONS W x D x H in mm	ARTICLE NO.
TWPE-13	13 pcs.	60 mm	600 x 1080 x 1000	43.00.00.20

**TYPE DW**

## Cover transport trolley

STAINLESS STEEL 1.4301



- For easy transport and storage of covers after cleaning
- Very robust open version made of stainless steel
- Capacity: 10 stainless steel covers
- Push handle made of round steel
- Mobile version with plain bearing or ball bearing
- 2 rigid casters and 2 swivel casters made of polyamide, Ø 125 mm
- Swivel casters with locking mechanism

TYPE	CAPACITY	DIMENSIONS W x D x H in mm	ARTICLE NO.
DW-10	10 piece	840 x 1020 x 588	41.00.00.30



**TYPE TWV**

# Platform transport trolley

STAINLESS STEEL 1.4301



- The most robust for transporting heavy loads
- Frame and push handle made of sturdy tubular frame construction
- Loading platform optionally made of stainless steel or plastic (HDPE-500)
- Load bearing capacity: approx. 400 kg
- Loading area: W: 700 x D: 1,000 mm
- Optionally with or without platform upstand
- Ergonomic push handle made of round tube
- 2 rigid + 2 swivel casters, wheel Ø 125 mm [stainless steel housing]

**OPTIONS**

Swivel caster with locking mechanism	Article no. 99.90.00.81
Writing tablet [mounted on push handle]	Article no. 43.00.00.99

TYPE	VERSION	LOADING PLATFORM	DIMENSIONS	ARTICLE NO.
	Loading platform	W x D in mm	W x D x H in mm	
TWV-EG	Stainless steel, smooth, chamfered	700 x 1000	700 x 1100 x 930	49.00.01.50
TWV-EA	Stainless steel, flanged	700 x 1000	704 x 1100 x 930	49.00.01.51
TWV-KG	Plastic, smooth, chamfered	700 x 1000	700 x 1100 x 930	49.00.01.52
TWV-KA	Plastic, flanged	700 x 1000	704 x 1100 x 930	49.00.01.53

**TYPE WRRW**

## Beaded edge shelf trolley

STAINLESS STEEL 1.4301



- Very robust version, versatile in use
- Robust tubular frame made of stainless steel
- Permanently welded shelves with circumferential beaded edge
- 5 shelves with shelf spacing of 340 mm
- 2 rigid casters + 2 swivel casters made of polyamide, Ø 150 mm
- 2 swivel casters with locking mechanism

TYPE	SHELF	DIMENSIONS W x D x H in mm	ARTICLE NO.
WRRW	5	900 x 560 x 1600	49.00.01.06

Other dimensions on request!

**TYPE MRW**

## Shelf trolleys

STAINLESS STEEL 1.4301



- Closed compartment shelves, optionally also perforated [Load capacity with evenly distributed load: 150 kg per shelf]
- max. total load: 400 kg
- Number of shelves optionally expandable up to 9
- Adjustable in 165 mm increments
- Mobile with swivel casters Ø 125 mm, two with locking mechanism
- Incl. deflector rollers
- Type MRW-0: Shelf perforated
- Type MRW-G: Shelf solid

Available in various designs and dimensions!

Please note: The effective size is approximately 67 mm narrower than the nominal size!

Type MRW-0

**TYPE STSW**

## Parts service trolley

STAINLESS STEEL 1.4301



- Practical solutions for butcheries and meat processing facilities
- Cutting sets and machine parts always readily available at one location
- No damage to the filler pipe, fin mill & bowl cutter
- Perforated tray for storage and drying of small parts
- Sturdy mountings for, for example, scrubbing pads
- Space for four E2 containers [e.g. for maintenance tools, spare parts]
- 4 polyamide swivel casters with locking mechanism, Ø 125 mm

TYPE	DIMENSIONS	ARTICLE NO.
	W x D x H in mm	
STSW-99/60	990 x 600 x 1235	43.00.00.50

Other versions on request!

**TYPE FTW**

## Format parts trolley

STAINLESS STEEL 1.4301



- Practical solution for the food industry
- Mobile stainless steel construction for secure storage and cleaning of
- high-quality format and machine parts, always readily available in one place
- No damage to machine and format parts
- Various, stable suspensions for e.g. filter formats, nozzles etc.
- 4 polyurethane swivel casters, 2 with locking mechanism, Ø 150 mm

TYPE	DESIGNATION	DIMENSIONS	ARTICLE NO.
		W x D x H in mm	
FOTW 100-60	ID 19-64827	1000 x 600 x 1440	20.00.00.00

Other versions on request!

**TYPE HKV-HBW-ST**

## Lifting and tilting device Standard



Standard lifting and tilting device for 200/300\* litre containers  
Standard feed trolley [according to DIN 9797]

**ADVANTAGES**

**Optical chain tension indicator:**

- Immediate error detection
- Higher machine availability
- Simple tensioning of the chain
- Simple, quick visual inspection

**Predetermined breaking point in the chain deflection:**

- Prevention of major damage

**Chain marking-neutral:**

- Simple replacement of the chain
- No adjustment of the end positions necessary

**Idler pinion made of stainless steel, with maintenance-free bearing:**

- Increased service life compared to plastic
- No maintenance and lubricant required

**Separate inspection openings:**

- Enables quick maintenance and repair
- Higher machine availability

**DESCRIPTION**

- Stationary version for floor mounting
- Robust industrial design guarantees a long service life
- Stainless steel surface: glass bead blasted
- The following parts are not made of stainless steel:  
Chain, tilting roller, gear motor, control unit and small parts
- Actuate the mechanical flushing valve
- Lifting column and control box in Hygienic-Design
- Control box incl. operating elements [UP / DOWN + main switch]  
on lifting column at service-friendly height by means of  
Spacer mounted
- Dead man's switch
- Chain: 16B-1, nickel-plated
- Stainless steel chain guard
- Container locking: automatic
- Container release: manual
- Manufactured according to CE standard, EU-compliant

**TECHNICAL DATA**

Load capacity	max. 350 kg [incl. trolley] Adjustability: 2-stage in 150 mm steps
Tilting angle	120°
Capacity	15 lifts/hour
Lifting speed	approx. 5 m/min
Mains supply	3x 400 V; 50 Hz with 5 m connection cable [without plug]
Gear motor power	0.75 kW
Protection class	IP65

TYPE	VERSION	TILTING HEIGHT** in mm	ARTICLE NO.
HKV-HBW-A-ST 1700	A	1400 - 1700	18.00.40.00
HKV-HBW-A-ST 2000	A	1700 - 2000	18.00.40.04
HKV-HBW-A-ST 2300	A	2000 - 2300	18.00.40.08
HKV-HBW-A-ST 2600	A	2300 - 2600	18.00.40.12
HKV-HBW-A-ST 2900	A	2600 - 2900	18.00.40.16
HKV-HBW-A-ST 3200	A	2900 - 3200	18.00.40.20
HKV-HBW-B-ST 1700	B	1400 - 1700	18.00.40.01
HKV-HBW-B-ST 2000	B	1700 - 2000	18.00.40.05
HKV-HBW-B-ST 2300	B	2000 - 2300	18.00.40.09
HKV-HBW-B-ST 2600	B	2300 - 2600	18.00.40.13
HKV-HBW-B-ST 2900	B	2600 - 2900	18.00.40.17
HKV-HBW-B-ST 3200	B	2900 - 3200	18.00.40.21
HKV-HBW-C-ST 1780	C	1480 - 1780	18.00.40.02
HKV-HBW-C-ST 2080	C	1780 - 2080	18.00.40.06
HKV-HBW-C-ST 2380	C	2080 - 2380	18.00.40.10
HKV-HBW-C-ST 2680	C	2380 - 2680	18.00.40.14
HKV-HBW-C-ST 2980	C	2680 - 2980	18.00.40.18
HKV-HBW-C-ST 3280	C	2980 - 3280	18.00.40.22
HKV-HBW-D-ST 1780	D	1480 - 1780	18.00.40.03
HKV-HBW-D-ST 2080	D	1780 - 2080	18.00.40.07
HKV-HBW-D-ST 2380	D	2080 - 2380	18.00.40.11
HKV-HBW-D-ST 2680	D	2380 - 2680	18.00.40.15
HKV-HBW-D-ST 2980	D	2680 - 2980	18.00.40.19
HKV-HBW-D-ST 3280	D	2980 - 3280	18.00.40.23

**\* ATTENTION**

- When using a 300 litre lifting and feeding trolley, the tilting height is reduced by approx. 150 mm!
- Safety distance between lifting and feeding trolley and the appliance to be charged [e.g. hopper or similar] when tilted 120 mm, in accordance with DIN EN ISO 13854.

**\*\* NOTES**

- A safety fence is required from a tilting height of 2,300 mm [mechanical door or light curtain]
- From a tilting height of 3,200 mm, the HKV must also be secured to wall or ceiling on site.

**OPTIONS**

Chassis HKV, TYPE FG-HKV-HWB for Type A + B	Article no. 18.00.30.30
Chassis HKV, TYPE FG-HKV-HWB 90° for Type C + D	Article no. 18.00.30.31
Conversion of lifting and tilting devices (HKV) on HBW 120L	Article no. 18.00.30.35
Safety cage for HKV, Type I-T, with door	Article no. 18.00.30.42
Safety cage for HKV, Type II-LG, with light grid	Article no. 18.00.30.43
Clamping spanner for HKV, Type SP-HKV	Article no. 18.00.30.90
Guide rail for HKV, Type FS-HKV [running metres]	Article no. 18.00.30.91
Transport pallet for HKV	Article no. 18.00.30.49
Flex maintenance HKV	Article no. 99.89.99.18

**TYPE A**

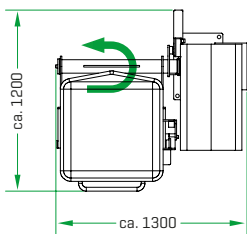

**TYPE B**

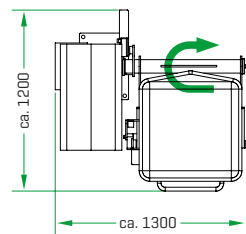

**TYPE C**

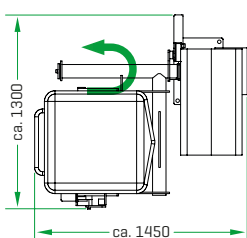

**TYPE D**

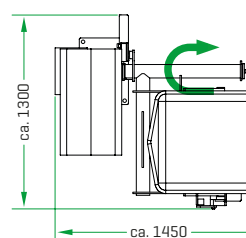

**TYPE HKV-HBW-HL**

## Lifting and tilting device Highline



Highline lifting and tilting device for 200/300\* litres  
Standard feed trolley [according to DIN 9797]

**ADVANTAGES**

**Optical chain tension indicator:**

- Immediate error detection
- Higher machine availability
- Simple tensioning of the chain
- Simple, quick visual inspection

**Predetermined breaking point in the chain deflection:**

- Prevention of major damage

**Chain marking-neutral:**

- Simple replacement of the chain
- No adjustment of the end positions necessary

**Idler pinion made of stainless steel, with maintenance-free bearing:**

- Increased service life compared to plastic
- No maintenance and lubricant required

**Separate inspection openings:**

- Enables quick maintenance and repair
- Higher machine availability

**DESCRIPTION**

- Stationary version for floor mounting
- Robust industrial design guarantees a long service life
- Stainless steel surface: glass bead blasted
- The following parts are not made of stainless steel:  
Chain, tilting roller, gear motor, control unit and small parts
- Actuate the mechanical flushing valve
- Lifting column and control box in Hygienic-Design
- Control box incl. operating elements [UP / DOWN + main switch]  
on lifting column at service-friendly height by means of  
Spacer mounted
- Dead man's switch
- Chain: 16B-1, stainless steel
- Stainless steel chain guard
- Container locking: automatic
- Container release: manual
- Manufactured according to CE standard, EU-compliant

**OPTIONS**

Chassis HKV, TYPE FG-HKV-HWB for Type A + B	Article no. 18.00.30.30
Chassis HKV, TYPE FG-HKV-HWB 90° for Type C + D	Article no. 18.00.30.31
Conversion of lifting and tilting devices [HKV] on HBW 120L	Article no. 18.00.30.35
Safety cage for HKV, Type I-T, with door	Article no. 18.00.30.42
Safety cage for HKV, Type II-LG, with light grid	Article no. 18.00.30.43
Clamping spanner for HKV, Type SP-HKV	Article no. 18.00.30.90
Guide rail for HKV, Type FS-HKV [running metres]	Article no. 18.00.30.91
Transport pallet for HKV	Article no. 18.00.30.49
Flex maintenance HKV	Article no. 99.89.99.18

TYPE	VERSION	TILTING HEIGHT** in mm	ARTICLE NO.
HKV-HBW-A-HL 1700	A	1400 - 1700	18.00.40.40
HKV-HBW-A-HL 2000	A	1700 - 2000	18.00.40.44
HKV-HBW-A-HL 2300	A	2000 - 2300	18.00.40.48
HKV-HBW-A-HL 2600	A	2300 - 2600	18.00.40.52
HKV-HBW-A-HL 2900	A	2600 - 2900	18.00.40.56
HKV-HBW-A-HL 3200	A	2900 - 3200	18.00.40.60
HKV-HBW-B-HL 1700	B	1400 - 1700	18.00.40.41
HKV-HBW-B-HL 2000	B	1700 - 2000	18.00.40.45
HKV-HBW-B-HL 2300	B	2000 - 2300	18.00.40.49
HKV-HBW-B-HL 2600	B	2300 - 2600	18.00.40.53
HKV-HBW-B-HL 2900	B	2600 - 2900	18.00.40.57
HKV-HBW-B-HL 3200	B	2900 - 3200	18.00.40.61
HKV-HBW-C-HL 1780	C	1480 - 1780	18.00.40.42
HKV-HBW-C-HL 2080	C	1780 - 2080	18.00.40.46
HKV-HBW-C-HL 2380	C	2080 - 2380	18.00.40.50
HKV-HBW-C-HL 2680	C	2380 - 2680	18.00.40.54
HKV-HBW-C-HL 2980	C	2680 - 2980	18.00.40.58
HKV-HBW-C-HL 3280	C	2980 - 3280	18.00.40.62
HKV-HBW-D-HL 1780	D	1480 - 1780	18.00.40.43
HKV-HBW-D-HL 2080	D	1780 - 2080	18.00.40.47
HKV-HBW-D-HL 2380	D	2080 - 2380	18.00.40.51
HKV-HBW-D-HL 2680	D	2380 - 2680	18.00.40.55
HKV-HBW-D-HL 2980	D	2680 - 2980	18.00.40.59
HKV-HBW-D-HL 3280	D	2980 - 3280	18.00.40.63

**\* ATTENTION**

- When using a 300 litre lifting and feeding trolley, the tilting height is reduced by approx. 150 mm!
- Safety distance between lifting and feeding trolley and the appliance to be charged [e.g. hopper or similar] when tilted 120 mm, in accordance with DIN EN ISO 13854

**\*\* NOTES**

- A safety fence is required from a tilting height of 2,300 mm [mechanical door or light curtain]
- From a tilting height of 3,200 mm, the HKV must also be secured to wall or ceiling on site.

**TYPE A**

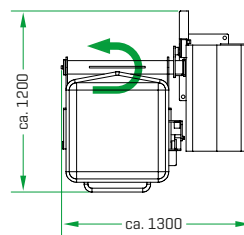

**TYPE B**

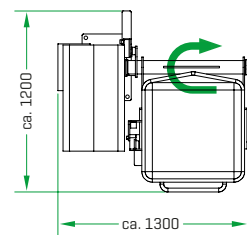

**TYPE C**

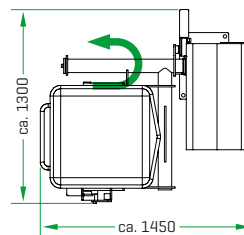

**TYPE D**

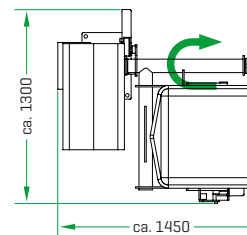



**TYPE HKV-F**

**Lifting and tilting device for barrels**

STAINLESS STEEL 1.4301



- Suitable for lifting and tilting of barrels
- Robust industrial design guarantees a long service life
- Various tilting heights available from 1,400 to 4,100 mm
- Tilt direction versions Type A or B or C-90° or D-90° available
- Stationary version or with optional trolley
- Load capacity as required
- High-pressure cleaning possible, protection class: IP65
- Mechanical safety device: Chain breakage protection

TYPE	VERSION	TILTING HEIGHT in mm	ARTICLE NO.
HKV-F	Type B	as required from 1,400 - 4,100	18.00.30.54

**OPTIONS**

Chassis Type FG-F [only up to max. tilting height 2,300 mm]	on request
Version Type C-90° and Type D-90°	on request
Type A version	on request
Safety cages, safety equipment	on request

**TYPE HKV-E2**

## Lifting and tilting device for Euro container [E2]

STAINLESS STEEL 1.4301



- For lifting and tilting Euro containers [E2]
- Robust industrial design guarantees a long service life
- Almost completely made of stainless steel
- Stainless steel surface, glass bead blasted
- Stationary version, optionally available with trolley
- Load bearing capacity 350 kg (incl. E2 container)
- High-pressure cleaning possible, protection class: IP65
- Mechanical safety device (special chain breakage protection)

TYPE	VERSION	TILTING HEIGHT in mm	ARTICLE NO.
HKV-E2 1700-A	Type A	1400 - 1700	18.00.30.32

**OPTIONS**

Chassis type A	Article no. 18.00.30.30
Safety cages, safety equipment	on request
HKV-E2 type B version	on request
Version Type C-90° and Type D-90°	on request

**TYPE HKV-GB-1S**

**Lifting and tilting device for big boxes (1 column)**

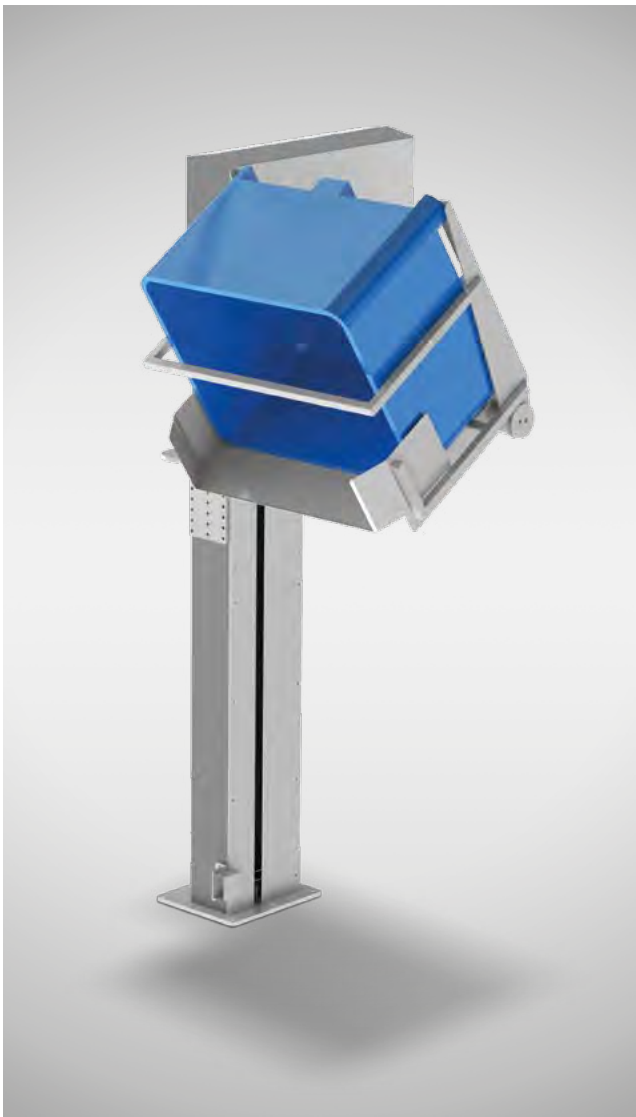

**TYPE HKV-GB-1S-ST**

Standard lifting and tilting device up to max. 1,200 x 1,000 x 800 mm and a max. load capacity of 750 kg [incl. container; optional 1,000 kg load capacity available on request].

- Emptying via narrow side.
- Stationary version for floor mounting
- Robust industrial design guarantees a long service life
- Stainless steel surface: glass bead blasted
- The following parts are not made of stainless steel: Chain, tilting roller, gear motor, control unit and small parts
- Actuate the mechanical flushing valve
- Lifting column and control box in Hygienic-Design
- Control box incl. operating elements [UP / DOWN + main switch + reset switch for protective grille installation] mounted on lifting column at a service-friendly height using spacers
- Dead man's switch
- Stainless steel chain guard
- Optical chain tension indicator ADVANTAGES: Immediate fault detection, higher machine availability, simple chain tensioning, quick and easy visual inspection
- Predetermined breaking point for the chain deflection ADVANTAGE: Prevention of major damage
- Chain: neutral marking [no flags for sensor or similar] ADVANTAGES: Simple replacement of the chain, no need to adjust the end positions
- Stainless steel deflection pinion, with maintenance-free bearing ADVANTAGES: Increased service life compared to plastic, no maintenance and lubricant required
- Separate inspection openings ADVANTAGE: Enables quick maintenance and repair, higher machine availability
- Manufactured according to CE standard, EU-compliant

**TECHNICAL DATA**

Adjustability	2-stage in 150 mm steps
Tilting angle	120°
Capacity	~15 lifts/hour
Lifting speed	approx. 5 m/min
Mains supply	3x 400 V; 50 Hz with 5 m connection cable [without plug]
Gear motor power	1.5 kW
Protection class	IP 65 [HKV-HBW also IP 65]

**ATTENTION**

Safety distance between container and the device to be loaded [e.g. hopper or similar] in tilted state 120 mm, acc. DIN EN ISO 13854

TYPE Standard	VERSION	TILTING HEIGHT in mm	ARTICLE NO.
HKV-GB-1S-A-ST 2000-S	A	1700 - 2000	18.00.42.00
HKV-GB-1S-A-ST 2300-S	A	2000 - 2300	18.00.42.01
HKV-GB-1S-A-ST 2600-S	A	2300 - 2600	18.00.42.02
HKV-GB-1S-A-ST 2900-S	A	2600 - 2900	18.00.42.03
HKV-GB-1S-A-ST 3200-S	A	2900 - 3200	18.00.42.04
HKV-GB-1S-B-ST 2000-S	B	1700 - 2000	18.00.42.10
HKV-GB-1S-B-ST 2300-S	B	2000 - 2300	18.00.42.11
HKV-GB-1S-B-ST 2600-S	B	2300 - 2600	18.00.42.12
HKV-GB-1S-B-ST 2900-S	B	2600 - 2900	18.00.42.13
HKV-GB-1S-B-ST 3200-S	B	2900 - 3200	18.00.42.14
HKV-GB-1S-C-ST 2000-S	C	1700 - 2000	18.00.42.20
HKV-GB-1S-C-ST 2300-S	C	2000 - 2300	18.00.42.21
HKV-GB-1S-C-ST 2600-S	C	2300 - 2600	18.00.42.22
HKV-GB-1S-C-ST 2900-S	C	2600 - 2900	18.00.42.23
HKV-GB-1S-C-ST 3200-S	C	2900 - 3200	18.00.42.24
HKV-GB-1S-D-ST 2000-S	D	1700 - 2000	18.00.42.30
HKV-GB-1S-D-ST 2300-S	D	2000 - 2300	18.00.42.31
HKV-GB-1S-D-ST 2600-S	D	2300 - 2600	18.00.42.32
HKV-GB-1S-D-ST 2900-S	D	2600 - 2900	18.00.42.34
HKV-GB-1S-D-ST 3200-S	D	2900 - 3200	18.00.42.35

Other tilting heights on request!

**TYPE HKV-GB-1S-HL**

Highline lifting and tilting device

Essentially the same design as standard, but with the addition of:

- Chain: "Marathon"

ADVANTAGES: Permanently lubricated chain, largely resistant to chemicals

TYPE Highline	VERSION	TILTING HEIGHT in mm	ARTICLE NO.
HKV-GB-1S-A-HL 2000-S	A	1700 - 2000	18.00.42.43
HKV-GB-1S-A-HL 2300-S	A	2000 - 2300	18.00.42.44
HKV-GB-1S-A-HL 2600-S	A	2300 - 2600	18.00.42.45
HKV-GB-1S-A-HL 2900-S	A	2600 - 2900	18.00.42.46
HKV-GB-1S-A-HL 3200-S	A	2900 - 3200	18.00.42.47
HKV-GB-1S-B-HL 2000-S	B	1700 - 2000	18.00.42.53
HKV-GB-1S-B-HL 2300-S	B	2000 - 2300	18.00.42.54
HKV-GB-1S-B-HL 2600-S	B	2300 - 2600	18.00.42.55
HKV-GB-1S-B-HL 2900-S	B	2600 - 2900	18.00.42.56
HKV-GB-1S-B-HL 3200-S	B	2900 - 3200	18.00.42.57
HKV-GB-1S-C-HL 2000-S	C	1700 - 2000	18.00.42.63
HKV-GB-1S-C-HL 2300-S	C	2000 - 2300	18.00.42.64
HKV-GB-1S-C-HL 2600-S	C	2300 - 2600	18.00.42.65
HKV-GB-1S-C-HL 2900-S	C	2600 - 2900	18.00.42.66
HKV-GB-1S-C-HL 3200-S	C	2900 - 3200	18.00.42.67
HKV-GB-1S-D-HL 2000-S	D	1700 - 2000	18.00.42.73
HKV-GB-1S-D-HL 2300-S	D	2000 - 2300	18.00.42.74
HKV-GB-1S-D-HL 2600-S	D	2300 - 2600	18.00.42.75
HKV-GB-1S-D-HL 2900-S	D	2600 - 2900	18.00.42.76
HKV-GB-1S-D-HL 3200-S	D	2900 - 3200	18.00.42.77

Other tilting heights on request!

**TYPE HKV-GB-2S**

**Lifting and tilting device for large boxes [2 columns]**



**TYPE HKV-GB-2S-ST**

Standard lifting and tilting device for large boxes up to max. 1,200 x 1,000 x 800 mm and a load capacity of max. 1,000 kg [incl. container, optional 1,500 kg load capacity available on request]

- Emptying via narrow side
- Stationary version for floor mounting
- Robust industrial design guarantees a long service life
- Stainless steel surface: glass bead blasted
- The following parts are not made of stainless steel: Tilting roller, gear motor, control unit and small parts
- Actuate the mechanical flushing valve
- Lifting column and control box in Hygienic-Design
- Control box incl. operating elements [UP / DOWN + main switch + reset switch]
- Mounted on the lifting column at a service-friendly height using spacers
- Automatic switching for up and down [no dead man's switch] incl. safety fence
- Stainless steel chain guard
- Optical chain tension indicator  
ADVANTAGES: Immediate fault detection, higher machine availability, simple chain tensioning, quick and easy visual inspection
- Predetermined breaking point for the chain deflection  
ADVANTAGE: Prevention of major damage
- Chain: Marking neutral [no flags for sensor or similar]  
ADVANTAGES: Simple replacement of the chain, no need to adjust the end positions
- Stainless steel deflection pinion, with maintenance-free bearing  
ADVANTAGES: Increased service life compared to plastic, no maintenance and lubricant required
- Separate inspection openings  
ADVANTAGES: Enables quick maintenance and repair, higher machine availability
- Manufactured according to CE standard, EU-compliant

**ATTENTION**

Safety distance between the container and the appliance to be loaded [e.g. hopper or similar] when tilted 120 mm, acc. DIN EN ISO 13854

**TYPE HKV-GB-2S-HL**

Highline lifting and tilting device Essentially the same design as standard, but with the addition of:

- Chain: "Marathon"  
ADVANTAGES: Permanently lubricated chain, largely resistant to chemicals

TYPE Standard	EMPTYING	TILTING HEIGHT in mm	ARTICLE NO.
HKV-GB-2S-ST 2100-S	Narrow side	1800 - 2100	18.00.42.90
HKV-GB-2S-ST 2400-S	Narrow side	2100 - 2400	18.00.42.91
HKV-GB-2S-ST 2700-S	Narrow side	2400 - 2700	18.00.42.92
HKV-GB-2S-ST 3000-S	Narrow side	2700 - 3000	18.00.42.93
HKV-GB-2S-ST 3300-S	Narrow side	3000 - 3300	18.00.42.94

Other tilting heights on request!

TYPE Highline	EMPTYING	TILTING HEIGHT in mm	ARTICLE NO.
HKV-GB-2S-ST 2100-HL	Narrow side	1800 - 2100	18.00.43.02
HKV-GB-2S-ST 2400-HL	Narrow side	2100 - 2400	18.00.43.03
HKV-GB-2S-ST 2700-HL	Narrow side	2400 - 2700	18.00.43.04
HKV-GB-2S-ST 3000-HL	Narrow side	2700 - 3000	18.00.43.05
HKV-GB-2S-ST 3300-HL	Narrow side	3000 - 3300	18.00.43.06

Other tilting heights on request!

**TYPE SL-HBW**  
**Swing Loader**

---





For quick and easy emptying of 200/300 litre containers.  
 Standard feed trolley (DIN 9797).  
 Certified by the Employer's Liability Insurance Association (BG)!

- Robust industrial design guarantees a long service life
- Stainless steel surface glass bead blasted
- Frame and swing arm made entirely of stainless steel
- The following parts are not made of stainless steel:  
 Hydraulic unit, oil tank, hoses, wheels, control panel (plastic), small parts
- Electrohydraulic drive with food-grade oil
- Double-acting cylinder (UP + DOWN controlled)
- Integrated chute for precise emptying Chute width: 400 mm (or as required)
- Maintenance-free plastic bearings - Advantages:
  - No maintenance required
  - No lubricant used
- Hose rupture safety valve - Advantages:
  - No uncontrolled lowering
  - Increased security
- Manufactured according to CE standard, EU-compliant

**For mobile version:**

- Mobile medium 2 rigid + 2 swivel casters with ALL-Stop (= slewing ring + roller is blocked)
- Wheel blocks made of stainless steel
- Wheels (D: 150mm) made of PA/PU (low-noise)

**Dimensions:**

W: 1,280 x D: 1,330 x H: 1,360/2,410 mm

**TECHNICAL DATA**

Load capacity	max. 350 kg (incl. trolley)
Tilting angle	120°
Capacity	5 - 6 lifts/hour
Lifting speed	approx. 5 m/min (approx. 25 - 30 sec. per lift)
Mains supply	3x 400 V; 50 Hz
Control voltage	24 V/DC
Fuse protection	10 A (on site) with 5 m connection cable (without plug)
Ambient temperature	min. 4 °C to max. 40 °C
Gear motor power	1.5 kW
Protection class	IP65

TYPE	VERSION	TILTING HEIGHT in mm	ARTICLE NO.
SL-HBW-F 350/1200	Mobile	1200	18.00.40.83
SL-HBW-F 350/1300	Mobile	1300	18.00.40.84
SL-HBW-F 350/1400	Mobile	1400	18.00.40.85
SL-HBW-S 350/1200	Stationary	1200	18.00.40.80
SL-HBW-S 350/1300	Stationary	1300	18.00.40.81
SL-HBW-S 350/1400	Stationary	1400	18.00.40.82

**OPTIONS**

Chute extension, e.g. to reach a tilting height of 1,100 mm	Article no. 18.00.40.86
Standard stainless steel control panel	Article no. 18.00.40.87
HD stainless steel control panel	Article no. 18.00.40.88
Switch cabinet left, standard version; lateral (left)	Article no. 18.00.40.89
Switch cabinet left, HD version; lateral (left)	Article no. 18.00.40.90
Switch cabinet right, standard version; lateral (right)	Article no. 18.00.40.91
Switch cabinet right, HD version; lateral (right)	Article no. 18.00.40.92
Safety gear for Swing Loader SL-HBW-F	Article no. 18.00.40.93
Pallet for Swing Loader SL-HBW (untreated wood)	Article no. 18.00.40.98
Pallet for Swing Loader SL-HBW (wood IPPC)	Article no. 18.00.40.99
Installation and commissioning Swing Loader SL-HBW	Article no. 18.00.40.97

**TYPE SL-GB**  
**Swing Loader**

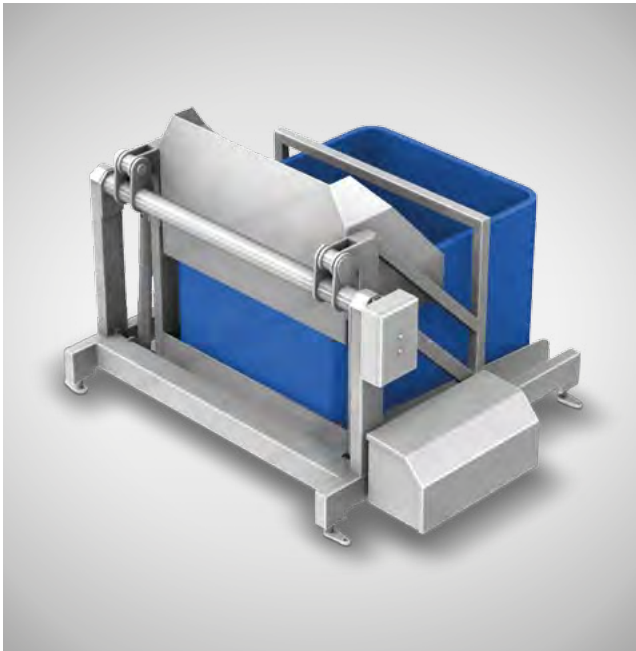

For quick and easy emptying of containers with maximum dimensions: W: 1,200 x D: 1,000 x to H: 800 mm [or on request], load capacity 1,000 kg

- Straight container infeed and emptying of the containers via the long side
- Stationary version [mobile version possible from tilting height 1,000 to 1,300 mm]
- Robust industrial design guarantees a long service life
- Stainless steel surface glass bead blasted
- Frame and swing arm made entirely of stainless steel
- The following parts are not made of stainless steel:  
Hydraulic unit, oil tank, hoses, control panel [plastic], small parts
- Electrohydraulic drive with food-grade oil
- Double-acting cylinder [UP + DOWN controlled]
- Integrated chute for precise emptying
- Chute width: 800 mm [or as required]
- Maintenance-free plastic bearings,  
ADVANTAGE: No maintenance, no lubricant required
- Hose rupture safety valve  
ADVANTAGE: No uncontrolled lowering, increased safety
- Height-adjustable stainless steel feet with flange, incl. hole for floor mounting
- Manufactured according to CE standard, EU-compliant

TYPE	VERSION	TILTING HEIGHT	ARTICLE NO.
SL-GB-GL 1000/1000	Long side	1000 mm	18.00.41.00
SL-GB-GL 1000/1100	Long side	1100 mm	18.00.41.03
SL-GB-GL 1000/1200	Long side	1200 mm	18.00.41.06
SL-GB-GL 1000/1300	Long side	1300 mm	18.00.41.09
SL-GB-GL 1000/1400	Long side	1400 mm	18.00.41.12
SL-GB-GL 1000/1500	Long side	1500 mm	18.00.41.15
SL-GB-GL 1000/1600	Long side	1600 mm	18.00.41.85
SL-GB-GL 1000/1700	Long side	1700 mm	18.00.41.86
SL-GB-GL 1000/1800	Long side	1800 mm	18.00.41.87
SL-GB-GL 1000/1900	Long side	1900 mm	18.00.41.88
SL-GB-GL 1000/2000	Long side	2000 mm	18.00.41.89
SL-GB-GS 1000/1000	Narrow side	1000 mm	18.00.41.18
SL-GB-GS 1000/1100	Narrow side	1100 mm	18.00.41.21
SL-GB-GS 1000/1200	Narrow side	1200 mm	18.00.41.24
SL-GB-GS 1000/1300	Narrow side	1300 mm	18.00.41.27
SL-GB-GS 1000/1400	Narrow side	1400 mm	18.00.41.30
SL-GB-GS 1000/1500	Narrow side	1500 mm	18.00.41.33
SL-GB-GS 1000/1600	Narrow side	1600 mm	18.00.41.80
SL-GB-GS 1000/1700	Narrow side	1700 mm	18.00.41.81
SL-GB-GS 1000/1800	Narrow side	1800 mm	18.00.41.82
SL-GB-GS 1000/1900	Narrow side	1900 mm	18.00.41.83
SL-GB-GS 1000/2000	Narrow side	2000 mm	18.00.41.84

**OPTIONS**

Chassis for Swing Loader GB, TYPE FG-SL-GB	Article no. 18.00.41.40
Set-up spindle for SL-HBW/GB chassis, Type AFSP	Article no. 18.00.41.41
Guide rail for SL-GB, Type FS-SL-GB (maximum tilting height 1,300 mm)	Article no. 18.00.41.42
Sealing chute for SL-GB, Type DS-SL-GB, for emptying liquids	Article no. 18.00.41.43
Double funnel chute for SL-GB, Typ, Emptying in 2 HBW, DTS-SL-GB	Article no. 18.00.41.44
Tumbler chute for SL-GB, Type TS-SL-GB for feeding a tumbler	Article no. 18.00.41.46
Catch device, Type FGR-SL-GB for locking the SL	Article no. 18.00.41.47
Support for a lift and feed trolley 200 L, Type AHB-SL-GB	Article no. 18.00.41.48
Holder for octabin container, Type AOB-SL	Article no. 18.00.41.49
Fork mount for SL-GB, Type GA-SL-GB	Article no. 18.00.41.50
Variable container height adjustment, Type VBH-SL-GB	Article no. 18.00.41.51
Increased load capacity, Type ET-SL-GB 1500	Article no. 18.00.41.52
Adjustment of tilt angle, Type AKW-SL-GB	Article no. 18.00.41.53
Barrier light grid for SL-GB, Type AL-SL-GB	Article no. 18.00.41.54
Barrier with gate for SL-GB, Type AT-SL-GB	Article no. 18.00.41.55
Stainless steel oil tank SL-GB/HBW, Type ÖT-SL-GB/HBW	Article no. 18.00.41.56
Freezer version down to -28 °C	Article no. 18.00.41.57
Adaptation of control unit abroad, Type ASA for HKV and SL	Article no. 18.00.30.65
HD stainless steel control panel	Article no. 18.00.40.88
Standard stainless steel control panel	Article no. 18.00.40.87
Switch cabinet left, standard version; lateral [left]	Article no. 18.00.40.89
Switch cabinet left, HD version; lateral [left]	Article no. 18.00.40.90
Switch cabinet right, standard version; lateral [right]	Article no. 18.00.40.91
Switch cabinet right, HD version; lateral [right]	Article no. 18.00.40.92
Variable container height adjustment, Type VBH-HKV/SL-GB	Article no. 18.00.43.54
Drip trough for SL-GB, Type AR-HKV/SL-GB with side outlet	Article no. 18.00.43.52
Additional options	on request

**TECHNICAL DATA**

Load capacity	max. 1,000 kg [incl. container]
Tilting angle	120°
Capacity	5 - 6 lifts/hour
Lifting time per emptying	approx. 25 - 30 sec.
Mains supply	3x 400 V; 50 Hz
Control voltage	24 V/DC
Fuse protection	16 A [on site] with 5 m connection cable [without plug]
Ambient temperature	min. 4 °C to max. 40 °C
Hydraulic power unit	1.5 kW
Protection class	IP65

**TYPE CA**

## Charging systems



### Ergonomic weighing and picking

**VERSION**

- Stationary version for floor mounting
- Mainly made of stainless steel in Hygienic-Design
- Equipped with the number of tilting stations required by the customer
- Modularly expandable
- Available in a wide range of variants, adapted to the container types used by the customer
- Precise weighing on the withdrawal side in 200 ltr. and 300 ltr. Standard trolley
- Optional: Version with buffer chutes for better dosability when weighing
- Optional: Buffer chutes with perforation and juice channel for collecting meat juices
- Optional: Weighing via conveyor belt, for integration into production lines
- Can be customised to special containers according to customer requirements
- Highest accuracy and reliability in the weighing unit
- Manufacturer-independent terminals for customised applications can be offered individually or provided by the customer
- Flexibility and seamless integration into existing systems
- For optimum performance: Use of various hydraulic power units for the respective application
- Optional: Double unit for maintaining performance when the system is used by several operators [Production of 2 batches simultaneously in 2 weighing units]
- Optional: Design of the unit as a redundant system > Safety from machine failures
- Operation of the tilting units with safe dead man's control
- Maximum user safety in the electrical system thanks to built-in quality components
- Electric pushbuttons with 24 V/DC safety extra-low voltage for operators [IP67 / IP69k]
- Electrical and hydraulic lines are routed below the product to avoid cross-contamination through dripping water etc.
- Optional: Cleaning programme: All stations are moved to a predefined cleaning position [top]

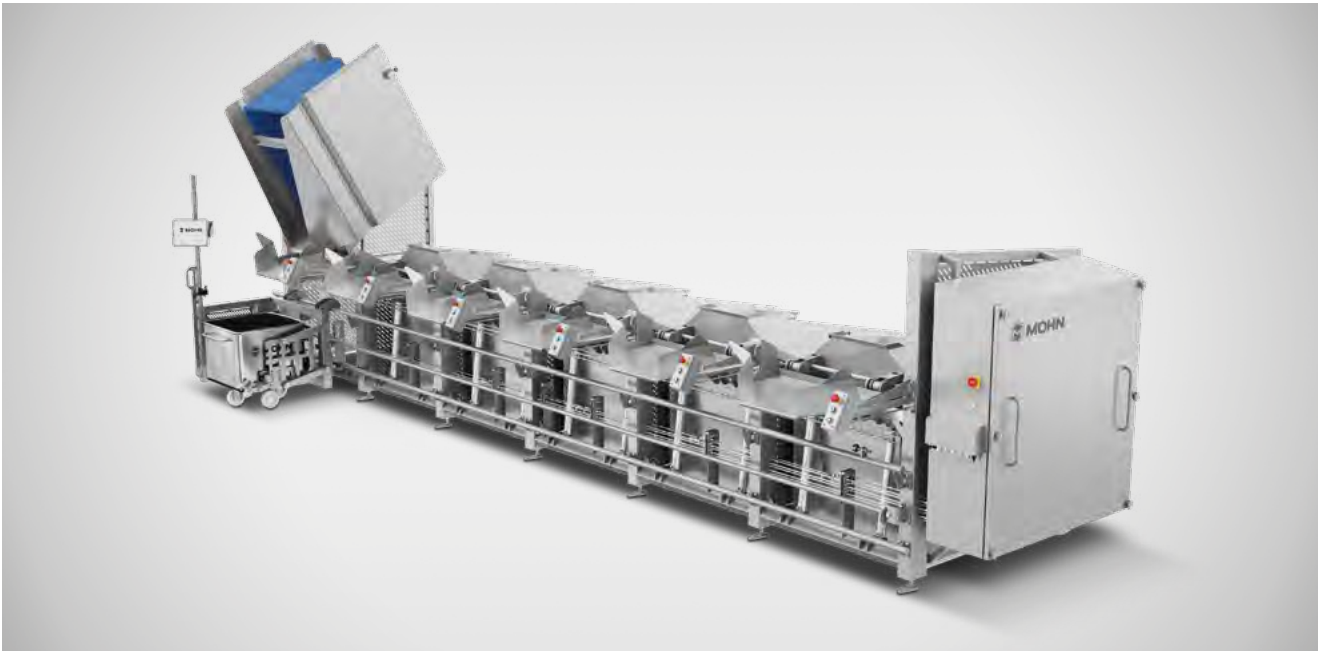

TYPE	VERSION	CAPACITY	LOAD BEARING CAPACITY	DIMENSIONS in mm	ARTICLE NO.
CA-HBW-I	Narrow version for standard trolleys	according to customer requirements	depending on design	depending on design	18.00.05.00
CA-HBW-II	Standard version for standard trolleys	according to customer requirements	depending on design	depending on design	18.00.05.01
CA-FB-I	Narrow design for conveyor belt	according to customer requirements	depending on design	depending on design	18.00.05.02
CA-FB-II	Standard version for conveyor belt	according to customer requirements	depending on design	depending on design	18.00.05.03

### Advantages of a charging system

- Ensures ergonomic and safe operation
- Offers the option of integrating a recipe programme in the terminal
- Available in a wide range of variants, suitable for different containers
- Characterised by effortless cleaning with a high level of safety
- Enables problem-free integration into existing systems
- Guarantees flexibility, as the weighing terminal is manufacturer-independent

#### TECHNICAL DATA

Mains supply	3x 400 V; 50 Hz
Power	3 kW [1 hydraulic unit]
Protection class	IP65
Tilting angle	120°

#### OPTIONS

Enlargement of the system with a second weighing unit	on request
Drip trough for liquids	on request
Additional buffer slide	on request
We produce individually	as desired by the customer

**TYPE GHW OA-SEMI II**

**Pallet truck Semi stainless**



- The workhorse for continuous professional use in hygiene areas
- Stainless steel chassis, handle/drawbar, axle, pistons, bearings and pins
- Hot-dip galvanised tilt-back lever, rods
- Zinc-moulded pump and front rocker arm
- Reliable hydraulics, robust design
- 3-point manual release with release
- Swivel caster and tandem fork castors made of nylon
- Optimum cleaning and resistance
- Wear-resistant surface

TYPE	LOAD CAPACITY	LENGTH in mm	HEIGHT in mm	ARTICLE NO.
GHW OA-Semi II	2500 kg	1480	1140	30.00.00.40

**TYPE GHW OA-V2A II**

**Pallet truck 100 % stainless steel**

STAINLESS STEEL 1.4301



- The stainless steel workhorse for professional continuous use in hygiene areas
- Made entirely of stainless steel!
- Stainless steel fork chassis, fork carriage, drawbar and wheel forks
- Reliable hydraulics, robust design
- 3-point manual release with release
- Swivel casters and tandem fork castors made of nylon
- Optimum cleaning and resistance
- Wear-resistant surface
- Optimum corrosion resistance

TYPE	LOAD CAPACITY	FORK LENGTH in mm	HEIGHT in mm	ARTICLE NO.
GHW OA-V2A II	2000 kg	1480	1140	30.00.00.41

**TYPE GHW-HPS**

## Pallet truck 100 % stainless steel [scales]

STAINLESS STEEL 1.4301



- The stainless steel workhorse with scales
- 2 different versions available
- Reliable hydraulics, robust design
- 3-point manual release with release
- Swivel casters and tandem fork castors made of nylon
- Optimum cleaning and resistance
- Wear-resistant surface
- Scales with LCD display at an ergonomic height

TYPE	LOAD CAPACITY	FORK LENGTH in mm	HEIGHT in mm	ARTICLE NO.
GHW-HPS-SEMI-V2A	2000 kg	1130	1140	30.00.00.55
GHW-HPS-V2A	1500 kg	1130	1140	30.00.00.56

**OPTIONS**

Printer for pallet truck Type GHW-HPS Article no. 30.00.00.57

**TYPE GHW-HL**

## Pallet truck 100% stainless steel 1.4301

STAINLESS STEEL 1.4301



- Manual pallet truck in hygienic design!
- Made entirely of stainless steel including the hydraulics
- Open design [skeleton construction], therefore very hygienic
- All corners and edges are very accessible thanks to the open design, thus the pallet truck can be easily and thoroughly cleaned without any problems
- Extremely low maintenance, all bearings are hermetically sealed and factory lubricated
- 3-point manual release [lowering, neutral, lifting]
- Swivel castors & Tandem fork castors made of nylon
- 3-year guarantee on pump unit [With proper use and maintenance!]
- Very quiet due to open design

TYPE	LOAD CAPACITY	FORK LENGTH in mm	HEIGHT in mm	ARTICLE NO.
GHW-HL	1500 kg	1145	1200	30.00.00.00

**TECHNICAL DATA**

Total length	1,580 mm	Lifting height	120 mm
Total width	520 mm	Weight	~70 kg

**OPTIONS**

PU castor wheels Article no. 30.00.00.98  
 Splash guard for load rollers Article no. 30.00.00.99



**TYPE SGHW-SEMI-M**

**Scissor pallet truck Semi-stainless, manual**



- Our semi-stainless scissor lift truck with manual operation
- Stainless steel chassis, handle, axles, screws, pins and pistons
- Lifting cylinder protected with zinc metal
- Scissor legs hot-dip galvanized
- Reliable hydraulics, robust design
- 2-stage manual pump with "Quick-Lift" valve
- 3-point manual release with release
- Polyamide swivel casters
- Nylon tandem fork castors
- Optimum cleaning and resistance
- Wear-resistant surface

TYPE	LOAD CAPACITY in kg	LIFTING HEIGHT in mm	ARTICLE NO.
SGHW-Semi-M	1000	800*	30.00.00.42

\*total

**TYPE GHW OA-V2A II**

**Scissor pallet truck Semi-stainless, automatic**



- Our semi-stainless scissor lift truck with automatic actuation
- Stainless steel chassis, handle, axles, screws, pins and pistons
- Lifting cylinder protected with zinc metal
- Scissor legs and battery box hot-dip galvanized
- Electrohydraulic pump
- Incl. battery and charger
- Reliable hydraulics, robust design
- 3-point manual release with release
- Polyamide swivel casters
- Nylon tandem fork castors
- Optimum cleaning and resistance
- Wear-resistant surface

TYPE	LOAD CAPACITY in kg	LIFTING HEIGHT in mm	ARTICLE NO.
SGHW Semi-A	1000	800*	30.00.00.43

\*total

**TYPE SGHW V2A-M**

## Scissor pallet truck 100 % stainless steel, manual

STAINLESS STEEL 1.4301



- Our 100% rust-free scissor lift truck with manual operation
- Made entirely from 100% stainless steel
- Suitable for humid environments and dry cleaning
- Reliable hydraulics, robust design
- 2-stage manual pump with "Quick-Lift" valve
- 3-point manual release with release
- Polyamide swivel casters
- Nylon tandem fork castors
- Optimum cleaning and resistance
- Wear-resistant surface

TYPE	LOAD CAPACITY in kg	LIFTING HEIGHT in mm	ARTICLE NO.
SGHW V2A-M	1000	800*	30.00.00.44

\*total

**TYPE SGHW V2A-A**

## Scissor pallet truck 100 % stainless steel, automatic

STAINLESS STEEL 1.4301



- Our 100% rust-free scissor lift truck with automatic actuation
- Made entirely from 100% stainless steel
- Suitable for humid environments and dry cleaning
- Electrohydraulic pump
- Incl. battery and charger
- Reliable hydraulics, robust design
- 3-point manual release with release
- Polyamide swivel casters
- Nylon tandem fork castors
- Optimum cleaning and resistance
- Wear-resistant surface

TYPE	LOAD CAPACITY in kg	LIFTING HEIGHT in mm	ARTICLE NO.
SGHW V2A-A	1000	800*	30.00.00.45

\*total

TYPE HHW-E /-M

## High-lift truck

---

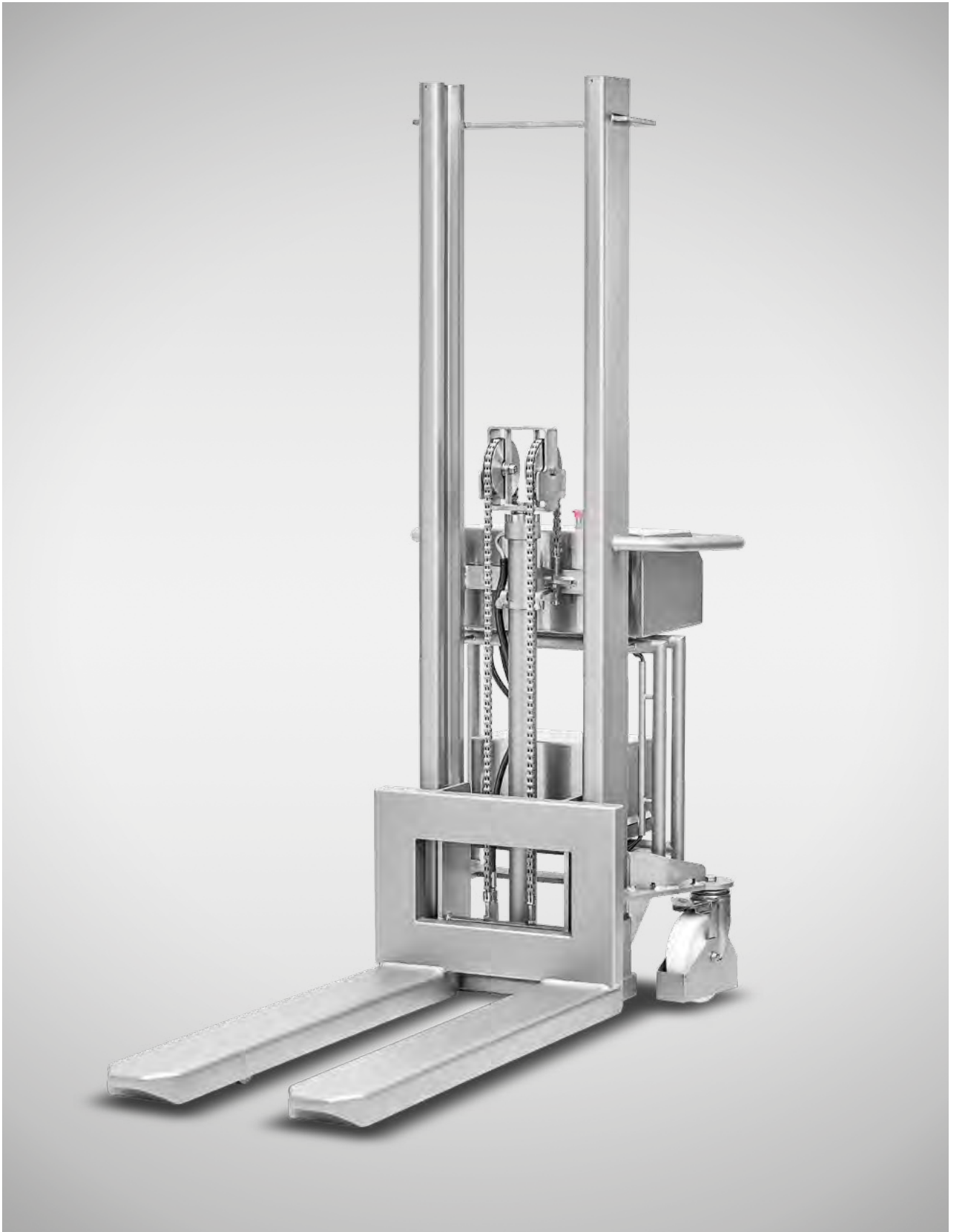



Type HHW-E V2A, top fork



Type HHW-E V2A, rear side

- Suitable for damp environments and chemical cleaning
- High-quality industrial truck
- 2 models available [manual or electric operation]
- Semi-stainless version or completely made of 100 % stainless steel
- Reliable hydraulics, robust design
- 2 nylon swivel casters, Ø 200x50
- 2 nylon tandem fork castors, Ø 82x70

TYPE	VERSION	WIDTH in mm	HEIGHT in mm	ARTICLE NO.
HHW-M Semi V2A	Semi-stainless - Manual	540	2000	30.00.00.48
HHW-E Semi V2A	Semi-stainless - Electr.	540	2000	30.00.00.49
HHW-M V2A	100 % stainless - Manual	540	2000	30.00.00.50
HHW-E V2A	100 % stainless - Electr.	540	2000	30.00.00.51

**TECHNICAL DATA**

Fork height [lowered]	89 mm
Load capacity	1,000 kg
Lifting speed	Adjustable
Lifting height	1,600 mm [total]
Fork length	1,155 mm
Fork width	540 mm
Fork width	160 mm

**TYPE HHW-E SEMI V2A**

- Stainless steel chassis etc.
- Partially hot-dip galvanised parts
- Electrically operated version
- Electrohydraulic pump
- Battery and charger included

**TYPE HHW-E V2A**

- Made entirely of 100% stainless steel
- Electrically operated version
- Electrohydraulic pump
- Battery and charger included

**TYPE HHW-M SEMI V2A**

- Stainless steel chassis etc.
- Partially hot-dip galvanised parts
- Manual operation

**TYPE HHW-M V2A**

- Made entirely of 100% stainless steel
- Manual operation

## Drainage Technology

---

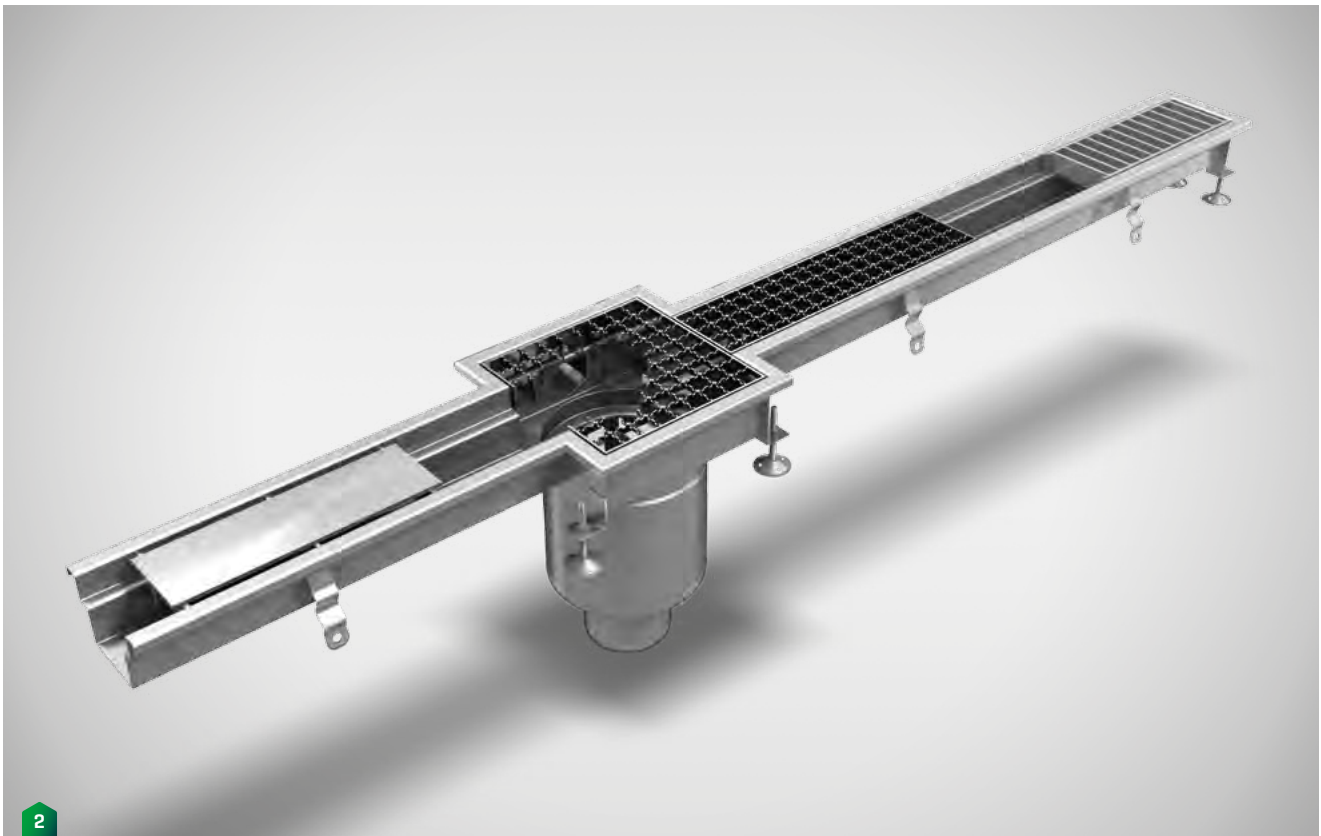
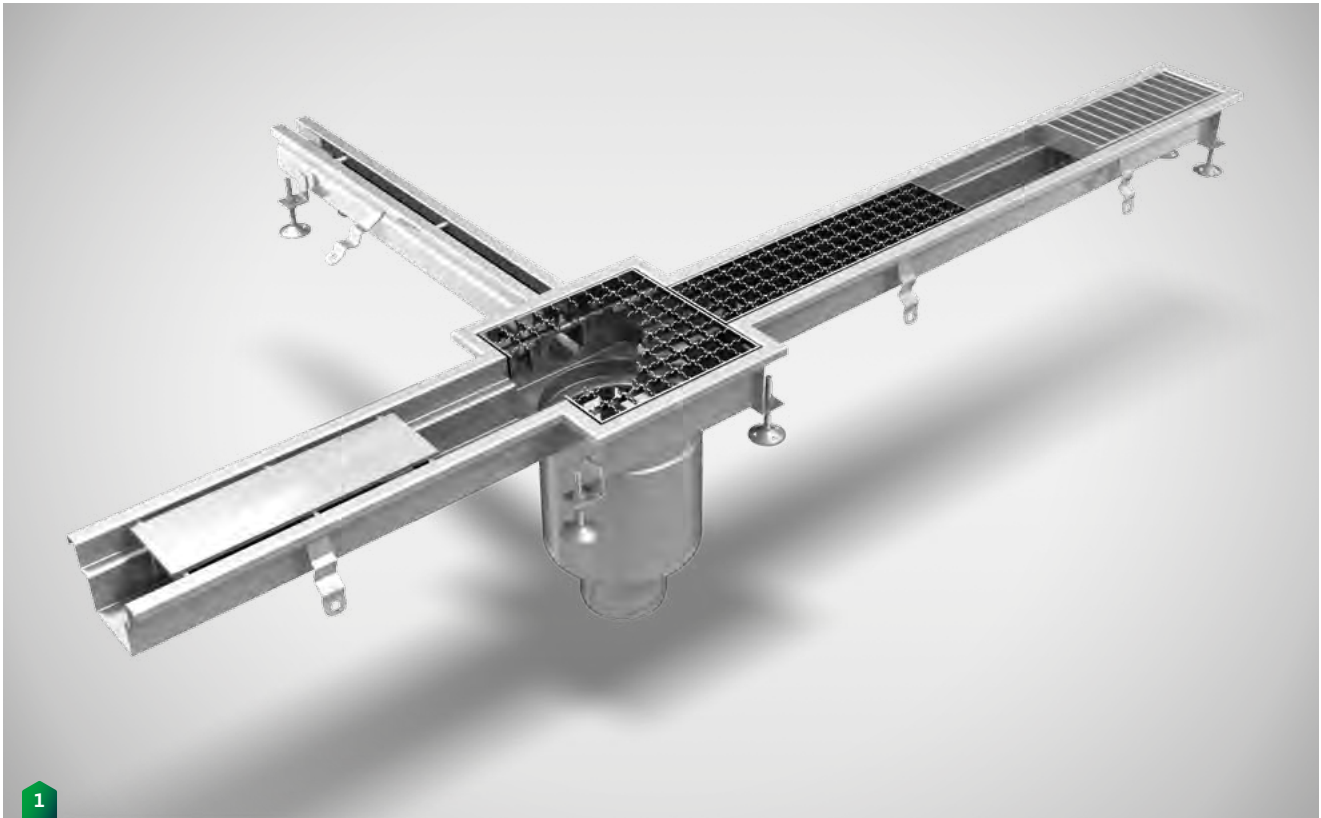

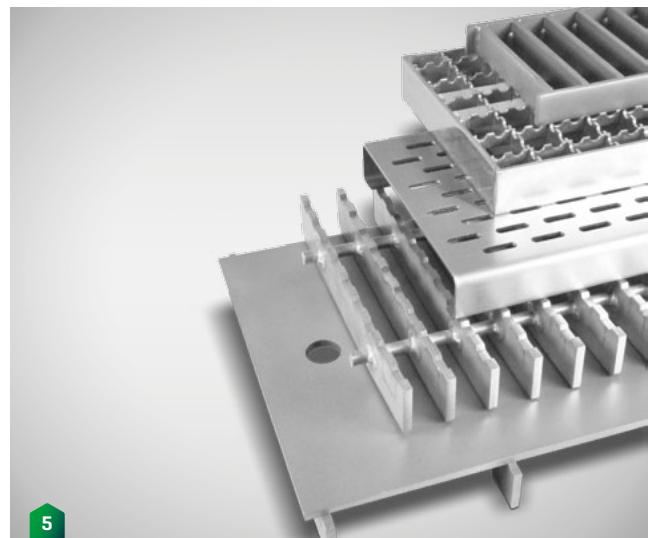

We manufacture all products according to your wishes.

- 1 Example: Box channel (W: 150 mm) with stitch slotted channel and drain body, 1-piece, vertical
- 2 Example: Box channel (W: 150 mm) with drain body, 1-piece, vertical
- 3 Drain body, one-piece, DN 100 vertical, 200 x 200 mm, complete with sludge collector and odour closure (also available in: 250 x 250; 300 x 300; 400 x 400 and round D: 200 + 255 mm)
- 4 Section: Drain body 2-part
- 5 Example: Covers for box channels



**ECOLAB**

**Detergents**



Food safety is the top target and is certainly not up for discussion. From experience, the physical intervention of the operating personnel in production and its environment is the main cause for the contamination of foodstuffs. For this reason, personal hygiene is a decisive factor in hygiene management. For safe and unobjectionable results with our personal hygiene systems we recommend to use detergents of our partner Ecolab.

The Ecolab products we recommend have been developed by professionals, especially for professionals and, in combination with our MOHN personal hygiene systems, achieve optimum results in all areas of application. Here, Ecolab offers customer-specific solutions for a wide range of industries, company sizes and object conditions.

The success of personal hygiene is largely dependent on user acceptance. Ecolab supports customers in the implementation and offers hygiene training, hand hygiene and skin protection plans, as well as easy-to-understand pictograms for visualizing correct personal hygiene directly at the hygiene stations.

Achieve safe and efficient results as well as optimised operation processes by means of innovative technologies and the unique expertise of our partner Ecolab. Please get in contact with Ecolab in order to find out more about possible support measures:

**ECOLAB DEUTSCHLAND GMBH**  
 40789 Monheim am Rhein  
 Telephone +49 (0) 2173-5991-888  
 Email: [ee-technik-de@ecolab.com](mailto:ee-technik-de@ecolab.com)



## Notes

---

---

---

---

---

---

---

---

---

---

---

---

---

---

---

---

---

---

---

---

---

---

---

---

---

# LIST OF PRODUCTS

## A –

Air/water gun – Type JET .....	173
Angle bracket, universal – Type KHD .....	182
<b>Apron and boot cleaning station</b>	
- Apron and boot cleaning station – Type STWA-I .....	102
- Apron and boot cleaning station – Type STWA-III .....	102
<b>Apron cleaning</b>	
- Apron cleaning cabinet – Type SRK .....	103
- Apron cleaning machine – Type Apron Master .....	101
- Apron cleaning machine – Type SW-TM 11 .....	103
<b>Apron coat rack – Type SSG-HL .....</b>	<b>216</b>
<b>Apron dispenser</b>	
- Apron dispenser, disposable – Type ESS-1 .....	21
- Apron dispenser, disposable – Type ESS-2 .....	21
<b>Apron hanger</b>	
- Apron hanger – Type SB .....	104
- Apron hanger – Type SB .....	217
- Apron hanger – Type SB-M .....	217
<b>Apron, sole and boot cleaning</b>	
- Apron, sole and boot cleaning station – Type STWA-II .....	102
- Apron, sole and boot cleaning walls – Type STWA .....	50
<b>Apron wall coat rack – Type SWG-HL .....</b>	<b>216</b>
<b>Apron wardrobe – Type S-WG/ -SG 12 .....</b>	<b>104</b>
<b>Attachment rail washing system – Type VSW .....</b>	<b>122</b>

## B –

<b>Ball trough – Type KM .....</b>	<b>338</b>
<b>Barrel trolley – Type FKR-E .....</b>	<b>344</b>
<b>Basins</b>	
- Basin - Hand wash basin and sink – Type HWA-F .....	16
- Basin - Hand wash basin / trough – Type HWB-SR-DT / WR-SR-DT 24V Ecoline .....	15
- Basin - Hand wash basin – Type HWB Highline .....	8
- Basin - Hand wash basin – Type HWB-K, HWB-S .....	14
- Basin - Hand wash basin – Type HWB-SA 55 .....	14
<b>Beaded edge shelf trolley – Type WRRW .....</b>	<b>350</b>
<b>Beaded edge tables – Type WRT .....</b>	<b>242</b>
<b>Bench</b>	
- Bench – Type SB-F .....	204
- Bench – Type SB-FE .....	205
- Bench – Type SB-FK .....	204
<b>Bonnet, coat and overall dispenser – Type EKS .....</b>	<b>22</b>
<b>Boot and apron cleaning</b>	
- Boot and apron cleaning station – Type STWA-I .....	102
- Boot and apron cleaning station – Type STWA-III .....	102

<b>Boot and clog dryer – Type STTG Highline .....</b>	<b>220</b>
<b>Boot and sole cleaning</b>	
- Boot and sole cleaning – Type Combiclean Ecoline .....	52
- Boot and sole cleaning – Type Combiclean Highline .....	53
<b>Boot, apron and sole cleaning</b>	
- Boot, apron and sole cleaning station – Type STWA .....	50
- Boot, apron and sole cleaning station – Type STWA-II .....	102
<b>Boot cleaning</b>	
- Boot cleaning machine – Type Boot-Master .....	49
- Boot cleaning – Pass-through boot cleaning machine – Type Boot-Star I .....	50
- Boot cleaning – Pass-through boot cleaning machine – Type Boot-Star II .....	51
- Boot cleaning trough – Type STWR .....	49
<b>Boot holder – Type STH-W Highline .....</b>	<b>210</b>
<b>Bottle trolley – Type FLR-E .....</b>	<b>344</b>
<b>Butchering and sorting tables</b>	
- Butchering and sorting tables – Type ZST .....	253
- Butchering and sorting tables – Type ZST .....	253

## C –

<b>Cabin washing</b>	
- Cabin washing plant – Type KWA-HBW-200/300 .....	142
- Cabin washing system – Type KWA-DUO, -STB, -RPB .....	144
- Cabin washing system – Type KWA-UDT .....	150
- Cabin washing system – Type KWA-UGR .....	152
<b>Can container</b>	
- Can container, lockable – Type KB Highline .....	84
- Can container, lockable – Type KB Highline .....	84
- Can container, lockable – Type KB Highline .....	183
- Can container, lockable – Type KB Highline .....	183
<b>Can holder</b>	
- Can holder, lockable – Type KH-GA .....	84
- Can holder, lockable – Type KH-GV .....	84
- Can holder – Type KH .....	84
- Can holder – Type KH .....	183
- Can holder – Type KH-CA .....	84
- Can holder – Type KH-CA .....	183
<b>Chairs, stools and seating aids – Type HMX, STMX, SMX .....</b>	<b>234</b>
<b>Changeover bench</b>	
- Changeover bench – Type USB .....	206
- Changeover bench – Type USB Ecoline .....	207
<b>Charging systems – Type CA .....</b>	<b>366</b>
<b>Cleancenter – Type HL-CC .....</b>	<b>13</b>
<b>Cleaning agents cabinet – Type PMS .....</b>	<b>295</b>

**Clean-Stations**

- Clean-Station – Type CSD Ecoline..... 38
- Clean-Station – Type CSD Highline..... 39
- Clean-Station – Type CSD-T Ecoline..... 38
- Clean-Station – Type CS Ecoline..... 38
- Clean-Station – Type CS-T Ecoline..... 38

**Clog and boot dryer – Type STTG Highline.....220**

**Clog and shoe holder – Type SC-W Highline.....210**

**Clothes hanger – Type KB.....214**

**Clothes rack – Type KA.....214**

**Coat dispenser – Type MAS..... 20**

**Coat hook rail – Type KHL.....213**

**Coat, overall and bonnet dispenser – Type EKS..... 22**

**Cold disinfection basin**

- Cold disinfection basin – Type DSB-K..... 89
- Cold disinfection basin – Type DSB-MB/K..... 89

**Compartment cabinets**

- Compartment cabinets as desired by the customer.....296
- Compartment cabinets – Colours.....202
- Compartment cabinets – Options.....203
- Compartment cabinets with 3 compartments  
on top of each other – Type FS3.....192
- Compartment cabinets with 4 compartments  
on top of each other – Type FS4.....194
- Compartment cabinets with 5 compartments  
on top of each other – Type FS5.....196
- Compartment cabinets with 6 compartments  
on top of each other – Type FS6-AF-SZ-EU-G.....198
- Compartment cabinet – Type ASD-F 10.....294
- Compartment cabinet – Type FS-12.....295
- Compartment, shoe cabinet – Type SFS.....219

**Connecting hose – Type VSA.....177**

**Control box, external – Type EXS-HD..... 85**

**Cooking, smoking and defrosting trolleys – Type ATW-V, RKW-VM.....318**

**Cooling container – Type KB.....337**

**Coupling plug – Type KS.....175**

**Cover transport trolley – Type DW.....348**

**Cover-type washing system – Type HWA Highline.....117**

**D –**

**Defrost, cook and smoke trolleys – Type ATW-V, RKW-VM.....318**

**Desks**

- Desks – Standing desks – Type SPG-D.....281
- Desks – Standing desks – Type SPG-E.....280
- Desks – Standing desks – Type SPO.....278

- Desks – Wall-mounted desk – Type WPO.....276
- Desks – Wall-mounted desk – Type WPS-I.....277
- Desks – Wall-mounted desk – Type WPS-II.....277

**Detergents – ECOLAB.....376**

**Disinfection basin**

- Disinfection basin Ecoline – Type DSB-I..... 88
- Disinfection basin Highline – Type DSB-IV..... 88
- Disinfection basin – Type DB-E.....46
- Disinfection basin – Type DSB-II..... 89

**Disinfection**

- Disinfection – Clean-Station – Type CSD Ecoline..... 38
- Disinfection – Clean-Station – Type CSD Highline..... 39
- Disinfection – Clean-Station – Type CSD-T Ecoline..... 38
- Disinfection – Clean-Station – Type CS Ecoline..... 38
- Disinfection – Clean-Station – Type CS-T Ecoline..... 38
- Disinfection – Cold disinfection basin –Type DSB-K..... 89
- Disinfection – Cold disinfection basin – Type DSB-MB/K..... 89
- Disinfection – Dosing station – Type DOS..... 47
- Disinfection – Floor hygiene station – Type ProfilGate® aqua..... 82
- Disinfection – Hand disinfection automatic – Type Desipower V..... 24
- Disinfection – Hand disinfection – Type Desipower III..... 36
- Disinfection – Hand disinfection – Type Desipower V..... 36
- Disinfection – Knife basket disinfection basin – Type DSB-MK..... 90
- Disinfection – Knife basket disinfection tunnel – Type Steri-King.....91
- Disinfection mat – Type DM..... 44
- Disinfection – Mobile disinfection bath – Type DDB-R..... 45
- Disinfection – Mobile disinfection bath – Type DDB-R..... 83
- Disinfection – Mobile disinfection station – Type MD-PG..... 83
- Disinfection, soap dispenser –  
Type Desi-Star Highline, Soap-Star Highline..... 37
- Disinfection, soap dispenser – Type Soap-, Desi-Star Ecoline..... 37
- Disinfection, soap dispenser with turnstile, 2-lane –  
Type Duo-Soap-/Desi-Control Highline..... 43
- Disinfection, soap dispenser with turnstile –  
Type Soap-/Desi-Control Ecoline..... 40
- Disinfection, soap dispenser with turnstile –  
Type Soap-/Desi-Control Highline..... 41
- Disinfection, soap unit –  
Type Desi-Star Highline / Soap-Star Highline..... 37
- Disinfection, soap unit – Type Soap-, Desi-Star Ecoline..... 37
- Disinfection, soap unit with turnstile, 2-lane –  
Type Duo-Soap-/Desi-Control Highline..... 43
- Disinfection, soap unit with turnstile –  
Type Soap-/Desi-Control Ecoline..... 40
- Disinfection, soap unit with turnstile –  
Type Soap-/Desi-Control Highline..... 41

- Disinfection – Walk-through disinfection basin – Type DDB-S ..... 45
- Disinfection, water, foam nozzles – Type WD, SD, SL, DD ..... 178

**Dispenser**

- Coat dispenser – Type MAS ..... 20
- Coat, overall and bonnet dispenser – Type EKS ..... 22
- Disposable apron dispenser – Type ESS-1 ..... 21
- Disposable apron dispenser – Type ESS-2 ..... 21
- Disposable ear plug dispenser – Type EOS ..... 20
- Disposable face mask dispenser – Type EBS-M ..... 22
- Disposable face mask dispenser – Type MSS ..... 22
- Disposable glove dispenser – Type EHS-2 ..... 20
- Disposable glove dispenser – Type EHS-3 ..... 20
- Disposable glove dispenser – Type HSD ..... 20
- Glove dispenser – Type HSS-2 ..... 20
- Hairnet, face mask dispenser – Type EMS ..... 21
- Multi-Mix dispenser (disposable) – Type MMS ..... 22
- Protective goggles and face mask dispenser – Type EBS ..... 21
- Protective goggles and face mask dispenser – Type EBS ..... 21
- Towel dispenser, automatic – Type HTSP-E-VA ..... 18
- Towel dispenser, manual – Type HTSP ..... 18
- Universal dispenser, automatic – Type USP-E-VA ..... 18
- Universal dispenser, manual – Type USP-L ..... 18
- Universal dispenser, manual – Type USP-O ..... 18
- Universal dispenser, manual – Type USP-O ..... 18
- Utensil dispenser – Type US ..... 21

**Document tray – Type DA** ..... 85

**Dosing station – Type DOS** ..... 47

**Double hook rail – Type HL-D** ..... 212

**Double stage work tables – Type DST** ..... 250

**Drainage Technology** ..... 374

**Drawer block – Type ASL** ..... 269

**Drawer cabinet**

- Drawer cabinet as desired by the customer ..... 270
- Drawer cabinets – Type SCS ..... 268

**Drip-off and pasteurising grid – Type RPF 4** ..... 331

**Drop-arm turning lock – Type DS-DA** ..... 74

**Drying cabinet – Type TSD-II** ..... 219

**Dryrack – Type DR** ..... 19

**E –**

**Earplug dispenser, disposable – Type EOS** ..... 20

**Enquiry form for sink units and sink cabinets** ..... 108

**Enquiry form gratings** ..... 326

**Enquiry form pasteurisation and drip-off grid** ..... 330

**Enquiry form smoke trolley** ..... 320

**Enquiry form wire-mesh baskets** ..... 328

**Environmental cabinet – Type UWS** ..... 288

**Equipment washer**

- Equipment washer – Type TT 32-23 D.4 ..... 114
- Equipment washer – Type TT 32-23 D.5 ..... 113
- Equipment washer – Type TT 32-23 D.6 ..... 112
- Equipment washer – Type TT 32-23 D.7 ..... 111

**Escape route, handrail gate – Type GT** ..... 76

**Euroclean-Complete – Type EC** ..... 34

**Euro stacking containers**

- Euro stacking containers – Type ESTB-MG ..... 334
- Euro stacking containers – Type ESTB-MG ..... 334
- Euro stacking containers – Type ESTB-OG ..... 335

**External switch box – Type EXS-HD** ..... 85

**F –**

**Face mask dispenser**

- Face mask dispenser (disposable) – Type EBS-M ..... 22
- Face mask dispenser (disposable) – Type MSS ..... 22
- Face mask, hair net dispenser – Type EMS ..... 21
- Face mask, protective goggles dispenser – Type EBS ..... 21

**Feed and lifting trolleys – Type HBW** ..... 321

**Feed trolley pass-through washing system – Type DLWA-HBW** ..... 146

**Filling tables – Type FT** ..... 244

**Floor hygiene station – Type ProfilGate® aqua** ..... 82

**Foam, disinfection, water nozzles – Type WD, SD, SL, DD** ..... 178

**Foam station – Type Griff** ..... 165

**Foam technology**

- Foam technology, mobile – Type Griff-M ..... 171
- Foam technology, mobile – Type HT-K, HT-UP ..... 169
- Foam technology, mobile – Type Moby Foam ..... 170
- Foam technology packages, mobile – Type Griff, Typhoon ..... 156
- Foam technology packages, stationary – Type Naga, Yeti, Griff ..... 157
- Foam technology packages with main station –  
Type MD421, 422 ..... 158

**Foam/water guns**

- Foam/water guns – Type ST ..... 172
- Foam/water gun – Type ST 3225 Ergo ..... 173

**Format parts trolley – Type FTW** ..... 351

**G –**

**Garbage bag holder – Type MSH** ..... 23

**Gas cylinder storage cabinet – TYPE GFL** ..... 345

<b>Glove dispenser</b>		
- Glove dispenser [disposable] - Type EHS-2	20	
- Glove dispenser [disposable] - Type EHS-3	20	
- Glove dispenser - Type HSD	20	
- Glove dispenser - Type HSS-2	20	
<b>Glove dryer</b>		
- Glove dryer - Type HST-HF High-Flow	223	
- Glove dryer - Type HST-S	222	
- Glove dryer - Type HST-W	222	
<b>Glove holder - Type HSA</b>	211	
<b>Gratings enquiry form</b>	326	
<b>Grid frames</b>		
- Grid frames for smoking and cooking trolleys	324	
- Grid frames - Type GS-V	323	
- Grid frames - Type GS-V	325	
<b>H -</b>		
<b>Hairnet, face mask dispenser - Type EMS</b>	21	
<b>Hand cleaning</b>		
- Hand cleaning, disinfection - Cleancenter - Type HL-CC	13	
- Hand cleaning, disinfection - Mobile hygiene station - Type MHS-1	17	
- Hand cleaning, disinfection - Mobile hygiene station - Type MHS-2	17	
- Hand cleaning, disinfection - Mobile hygiene station - Type MHS-Eco	16	
<b>Hand disinfection</b>		
- Hand disinfection automatic - Type Desipower V	24	
- Hand disinfection - Type Desipower III	36	
- Hand disinfection - Type Desipower V	36	
<b>Hand dryer - Type Jet II</b>	19	
<b>Handrail</b>		
- Handrail, escape route gate - Type GT	76	
- Handrail gate [magnet] - Type MGT	77	
- Handrail - Type G	78	
- Handrail with chicane - Type G-S	80	
<b>Hand wash basins</b>		
- Hand wash basin and sink - Type HWA-F	16	
- Hand wash basin / trough - Type HWB-SR-DT / WR-SR-DT 24V Ecoline	15	
<b>Hand-washing basin</b>		
- Hand-washing basin - Type HWB Highline	8	
- Hand-washing basin - Type HWB-K, HWB-S	14	
- Hand-washing basin - Type HWB-SA 55	14	
<b>HD wall spacer - Type HD-WA</b>	22, 85, 301	
<b>Hearing protection hook strip - Type HL-EG</b>	212	
<b>High lift truck - Type HHW-E, -M</b>	372	
<b>Hook rail</b>		
- Hook rail - Coat hook rail - Type KHL	213	
- Hook rail - Double hook rail - Type HL-D	212	
- Hook rail - Hearing protection hook strip - Type HL-EG	212	
- Hook rail - Single hook rail - Type HL-E	212	
- Hook rail - Type HL-ECO	213	
<b>Hose bracket - Type SH-G</b>	182	
<b>Hose connector - Type SV-AG</b>	174	
<b>Hose guide, universal - Type USF</b>	182	
<b>Hose reel - Type SAR</b>	180	
<b>Hoses</b>		
- Hoses - Connecting hose - Type VSA	177	
- Hoses - Hygiene hoses - Type UHS	176	
- Hoses - Supply hose - Type ZS	177	
<b>Hygiene hoses - Type UHS</b>	176	
<b>Hygiene stations</b>		
- Hygiene station 1-lane - Type Check-In-Station I Highline	64	
- Hygiene station 1-lane - Type Check-In-Station II Ecoline	62	
- Hygiene station 1-lane - Type Check-In-Station II Highline	67	
- Hygiene station 1-lane - Type Check-In-Station III Ecoline	68	
- Hygiene station 1-lane - Type Check-In-Station III Highline	71	
- Hygiene station 1-lane - Type Clean-Check Ecoline	56	
- Hygiene station 1-lane - Type Clean-Check Highline	57	
- Hygiene station 1-lane - Type Combiclean-Control Ecoline	58	
- Hygiene station 1-lane - Type Combiclean-Control Highline	59	
- Hygiene station 2-lane - Type Clean-Check DUO Highline / Ecoline	60	
- Hygiene station 2-lane - Type Control-Star Highline / Ecoline	61	
- Hygiene station - Euroclean-Complete - Type EC	34	
- Hygiene station - Floor - Type ProfilGate@ aqua	82	
- Hygiene station - Hygienic Station - Type HS I+II	35	
- Hygiene station - Hygienic Station - Type HS III	35	
- Hygiene station - Type HS I+II	35	
- Hygiene station - Type HS III	35	
<b>Hygiene walls</b>		
- Hygiene walls, wall-mounted	28	
- Hygiene walls, with stand frame	29	
- Hygiene wall - Type HW-HWB HL1	30	
- Hygiene wall - Type HW-I	31	
- Hygiene wall - Type HW-J	31	
- Hygiene wall - Type HW-S	30	
<b>Hygienic rear wall</b>		
- Hygienic rear wall - Type H-RW	32	

- Hygienic rear wall – Type H-RW/S.....	33	- Can holder – Type KH .....	183
Hygienic separation wall – Type HTW.....	24	- Can holder – Type KH-CA .....	183
Hygienic shelves – Type HS.....	23	- Connecting hose – Type VSA.....	177
<b>I –</b>		- Coupling plug – Type KS.....	175
Infection control station – Type INFS / 40-160.....	25	- Feed hose – Type ZS.....	177
<b>K –</b>		- Foam and water gun – Type ST.....	172
Knife basket chute – Type MKRU .....	85	- Foam and water gun – Type ST 3225 Ergo.....	173
Knife basket cleaning machine – Type MKRM-T.....	94	- Foam station – Type Griff.....	165
Knife basket disinfection basin – Type DSB-MK.....	90	- Foam technology packages, mobile – Type Griff, Typhoon.....	156
Knife basket disinfection tunnel – Type Steri-King.....	91	- Foam technology packages, stationary –	
Knife basket holder – Type MKH.....	97	Type Naga, Yeti, Griff.....	157
Knife basket pass-through cleaning machine – Type MKRM-D.....	95	- Foam technology packages with main station –	
Knife basket pressure cleaner – Type MKDR .....	92	Type MD421, 422 .....	158
Knife basket safety cabinet – Type MK-S.....	98	- Hose bracket – Type SH-G.....	182
Knife basket transport trolley – Type MKTW.....	99	- Hose connector – Type SV-AG .....	174
Knife basket – Type MK.....	96	- Hose reel – Type SAR.....	180
<b>L –</b>		- Hygiene hoses – Type UHS .....	176
Large container pass-through washing system – Type DLWA-GB.....	148	- Low-pressure foam technology.....	154
Laundry collector cabinet – Type WSS .....	201	- Main, hygiene station – Type MD, MU.....	164
Laundry dispensing cabinets – Type WAS .....	200	- Mobile foam technology – Type Griff-M.....	171
Lift and feed trolleys – Type HBW.....	321	- Mobile foam technology – Type HT-K, HT-UP .....	169
Lifting and tilting device		- Mobile foam technology – Type Moby Foam.....	170
- Lifting and tilting device for barrels – Type HKV-F .....	356	- Nozzle set – Type Nozzle set .....	179
- Lifting and tilting device for Euro container [E2] –		- Quick coupling – Type SK.....	175
Type HKV-E2.....	357	- Quick coupling – Type SKW .....	174
- Lifting and tilting device for large boxes, 1 column –		- Stationary systems for water pressures 2-8 bar –	
Type HKV-GB-1S.....	358	Type Yeti, Naga.....	168
- Lifting and tilting device for large boxes, 2 column –		- Stationary systems for water pressures up to 50 bar –	
Type HKV-GB-2S.....	360	Type SD, SU.....	166
- Lifting and tilting device Highline – Type HKV-HBW-HL.....	354	- Stationary systems for water pressures up to 50 bar –	
- Lifting and tilting device Standard – Type HKV-HBW-ST.....	352	Type Yeti / SE 11 .....	167
Lifting systems – Type LA-RF .....	226	- Stationary systems – Type BF, BW H.....	163
Lifting tackle cabinet – Type ASM.....	288	- Swivel joint – Type DG-360°.....	174
Lockers, two-storey – Type GS2.....	188	- Universal angle bracket – Type KHD.....	182
Lockers – Type GS1 .....	186	- Universal hose guide – Type USF.....	182
Lockers Z-shape – Type GSZ.....	190	- Wall bracket – Type WH .....	180
Low-pressure foam technology		- Wall slewing console – Type WSK.....	181
- Air and water gun – Type JET.....	173	- Water, foam and disinfectant nozzles – Type WD, SD, SL, DD.....	178
- Can container, lockable – Type KB Highline .....	183	- Water lances – Type WL .....	179
- Can container, lockable – Type KB Highline.....	183	- LWater pistol – Type WP.....	172
		- Workplace packages – Type Highline SD.....	160
		- Workplace package – Type Ecoline SE11.....	159

## M –

### Machine benches

- Machine benches – Type MTF.....237
- Machine benches – Type MTS.....236

### Magnetic handrail gate – TYPE MGT..... 77

### Magnetic wing gate – Type MFT..... 75

### Main, hygiene station –Type MD, MU .....164

### Mirror, stainless steel – Type ESP..... 23

### Mixing trough

- Mixing trough – Type MM-150.....338
- Mixing trough – Type MM-200.....339
- Mixing trough – Type MM-300.....339

### Mobile disinfection bath

- Mobile disinfection bath – Type DDB-R..... 45
- Mobile disinfection bath – Type DDB-R..... 83

### Mobile disinfection station – Type MD-PG..... 83

### Mobile foam technology

- Mobile foam technology – Type Griff-M.....171
- Mobile foam technology – Type HT-K, HT-UP .....169
- Mobile foam technology – Type Moby Foam.....170

### Mobile hygiene station

- Mobile hygiene station – MHS-1 ..... 17
- Mobile hygiene station – Type MHS-2..... 17
- Mobile hygiene station – Type MHS-Eco..... 16

### Modular shelf system – Type MR .....306

### Multi-Mix dispenser [disposable] – Type MMS ..... 22

### Multi tank pass-through washing system

- Multi tank pass-through washing system for boxes and pallets – Type DLWA 600-2T / 2+PAL – 1000-2T / 2+PAL Highline.....138
- Multi tank pass-through washing system for boxes – Type DLWA 400-2T – 1000-3T Highline.....132

## N –

### Nozzle set – Type Nozzle set .....179

## O –

### Open-fronted storage cabinet – Type SKS.....289

### Overall, bonnet and Kittel dispenser – Type EKS ..... 22

## P –

### Pallet rack practical example .....313

### Pallet rack system – Type PRS .....312

### Pallet truck

- Pallet truck, 100% stainless steel [scale] – Type GHW-HPS.....369
- Pallet truck, 100% stainless steel – Type GHW OA-V2A II.....368
- Pallet truck, 100% stainless steel 1.4301 – Type GHW-HL.....369
- Scissor pallet truck, 100% stainless steel, automatic – Type SGHW V2A-A.....371
- Scissor pallet truck, 100% stainless steel, manual – Type SGHW V2A-M.....371
- Scissor pallet truck, semi-stainless, automatic – Type GHW OA-V2A II .....370
- Scissor pallet truck, semi-stainless, manual – Type SGHW Semi-M .....370
- Pallet truck, semi-stainless – Type GHW OA-Semi II .....368

### Pallet washing system – Type DLWA-PAL .....140

### Paper baskets – Type PK-D/ PK-E..... 23

### Parts service trolley – Type STSW .....351

### Parts wash station – Type TW.....105

### Pass-through boot cleaning machine

- Pass-through boot cleaning machine – Type Boot-Star I ..... 50
- Pass-through boot cleaning machine – Type Boot-Star II ..... 51

### Pass-through washing systems

- Feed trolley pass-through washing system – Type DLWA-HBW.....146
- Large container pass-through washing system – Type DLWA-GB .....148
- Multi tank pass-through washing system for boxes and pallets – Type DLWA 600-2T / 2+PAL – 1000-2T / 2+PAL Highline.....138
- Multi tank pass-through washing system for boxes – Type DLWA 400-2T – 1000-3T Highline.....132
- Pass-through washing system – Type DLWA-A 180 Ecoline .....126
- Pass-through washing system for boxes and baking trays – Type DLWA 250 / 400-Back Highline.....134
- Pass-through washing system for boxes – Type DLWA 180 Ecoline.....124
- Pass-through washing system for boxes – Type DLWA 300 Ecoline.....125
- Single tank pass-through washing system for boxes and pallets – Type DLWA 300 / 2+PAL – 400 / 2+PAL Highline.....136
- Single tank pass-through washing system for boxes – Type DLWA 200 – 400 Highline.....130

### Pasteurisation and drip-off grid enquiry form .....330

### Pasteurisation and drip-off grid – Type RPF 4 .....331

### PC cabinets

- PC cabinets as desired by the customer .....300
- PC cabinets – Type PCS.....298

### Plastic trolley – Type KSR.....342

### Plates transport trolley – Type TWPE.....348



<b>Platform transport trolley – Type TWV</b> .....	349	- Serving trolley Highline – Type SW Highline .....	346
<b>Portal turnstile</b>		<b>Sheet metal frames – Type BS</b> .....	323
- Portal turnstile – Type PDK 1-lane.....	73	<b>Shelf – Storage rack</b>	
- Portal turnstile – Type PDK 2-lane.....	73	- Shelf – Storage rack – Type LR-E .....	310
<b>Practical examples</b>		- Shelf – Storage rack – Type LR-E/U.....	311
- Practical example of social area equipment.....	208	- Shelf – Storage rack – Type LR-K .....	309
- Practical examples of handrails.....	81	<b>Shelf systems</b>	
- Practical examples of Handrails.....	81	- Modular shelf system – Type MR.....	306
- Practical examples of sink units.....	106	- Pallet rack system – Type PRS.....	312
<b>ProfilGate® aqua, floor hygiene station</b> .....	82	- Sliding shelves system – Type SRS.....	307
<b>Push-through dishwasher – Type TT 28-26</b> .....	110	- Storage system – Type LS .....	308
		- System rack – Type SR Highline .....	304
		<b>Shelf trolley – Type MRW</b> .....	350
<b>Q –</b>		<b>Shoe and clog holder – Type SC-W Highline</b> .....	210
<b>Quick coupling</b>		<b>Shoe and compartment cabinet – Type SFS</b> .....	219
- Quick coupling – Type SK .....	175	<b>Shoe wall shelf – Type SWR</b> .....	218
- Quick coupling – Type SKW .....	174	<b>Single hook rail – Type HL-E</b> .....	212
		<b>Single tank pass-through washing systems</b>	
<b>R –</b>		- Single tank pass-through washing system for boxes and pallets – Type DLWA 300 / 2+PAL – 400 / 2+PAL Highline.....	136
<b>Roll box – Type RB-E</b> .....	19	- Single tank pass-through washing system for boxes – Type DLWA 200 – 400 Highline.....	130
<b>Roll holder</b>		<b>Sink and hand wash basin – Type HWA-F</b> .....	16
- Roll holder – Type RH-S1.....	27	<b>Sink units</b>	
- Roll holder – Type RH-SF1.....	27	- Sink units and sink cabinets Enquiry form .....	108
- Roll holder – Type RH-W.....	26	- Sink units Practical examples .....	106
- Roll holder – Type RH-W2 .....	26	<b>Sliding shelves system – Type SRS</b> .....	307
<b>Rotary basket washing system for customer-specific items to be washed – Type DWA Highline</b> .....	118	<b>Small compartment cabinet – Type KGS</b> .....	191
<b>Round container – Type RBR</b> .....	343	<b>Smoke stick trolley – Type RSW</b> .....	322
		<b>Smoke stick washing system – Type RSW</b> .....	120
		<b>Smoke trolley</b>	
<b>S –</b>		- Smoke trolley enquiry form .....	320
<b>Sack truck – Type SK-E VG</b> .....	345	- Smoke trolley – Type RW.....	316
<b>Sausage cart – Type WLW</b> .....	319	<b>Smoking, defrosting and cooking trolleys – Type ATW-V, RKW-VM</b> .....	318
<b>Scissor pallet truck</b>		<b>Smoking skewers – Type RS</b> .....	322
- Scissor pallet truck, 100% stainless steel, automatic – Type SGHW V2A-A.....	371	<b>Social area equipment Practical example</b> .....	208
- Scissor pallet truck, 100% stainless steel, manual – Type SGHW V2A-M.....	371	<b>Sole and boot cleaning</b>	
- Scissor pallet truck, semi-stainless, automatic – Type GHW OA-V2A II .....	370	- Sole and boot cleaning – Type Combiclean Ecoline.....	52
- Scissor pallet truck, semi-stainless, manual – Type SGHW Semi-M .....	370	- Sole and boot cleaning – Type Combiclean Highline.....	53
<b>Seating aids, chairs and stools – Type HMX, STMX, SMX</b> .....	234	<b>Sole, boot and apron cleaning stations – Type STWA-II</b> .....	102
<b>Serving trolley</b>		<b>Sole, boot, apron washing walls – Type STWA</b> .....	50
- Serving trolley Ecoline – Type SW Ecoline.....	347	<b>Sole cleaning</b>	
		- Sole cleaning machine – Type Sole-Master .....	48
		- Walk-through sole cleaning machine 1-lane – Type Sole-Star Ecoline.....	54

- Walk-through sole cleaning machine 1-lane -  
Type Sole-Star Highline ..... 55
- Space-saving clothes cabinet – Type RSG** .....191
- Spice rack – Type GWB** .....302
- Stab protective apron high-pressure cleaner – Type SSR-H** .....101
- Stab protective glove cleaners**
- Stab protective glove high-pressure cleaner – Type SHR-H .....100
- Stab protective glove low-pressure cleaner – Type SHR-N .....100
- Stage work tables**
- Stage work tables – Type SAD .....248
- Stage work tables – Type SAH .....246
- Stage work tables – Type SAH-H, DST-H .....252
- Stainless steelmirror – Type ESP** ..... 23
- Stainless steel steering trolley – Type WRR** .....342
- Stainless steel work cabinets** .....255
- Stand frame – Type STG** .....211
- Standing aid – Type ST-HL** .....235
- Standing desk cabinets**
- Standing desk cabinets – Type SPG-S/D .....283
- Standing desk cabinets – Type SPG-S/E .....282
- Standing desks**
- Standing desks – Type SPG-D .....281
- Standing desks – Type SPG-E .....280
- Standing desks – Type SPD .....278
- Stationary systems**
- Stationary systems for water pressures 2-8 bar -  
Type Yeti, Naga .....168
- Stationary systems for water pressures up to 50 bar -  
Type SD, SU .....166
- Stationary systems for water pressures up to 50 bar -  
Type Yeti / SE 11 .....167
- Stationary systems – Type BF, BW H .....163
- Steering trolley, stainless steel – Type WRR** .....342
- Stools, seating aids and chairs – Type HMX / STMX / SMX** .....234
- Storage cabinets**
- Storage cabinets – Type AS .....290
- Storage cabinets – Type ASD .....292
- Storage cabinets – Type ASD Highline .....293
- Storage cabinets – Type AS Highline .....291
- Storage racks**
- Storage rack – Type LR-E .....310
- Storage rack – Type LR-E/U .....311
- Storage rack – Type LR-K .....309
- Storage system – Type LS** .....308
- Supply hose – Type ZS** .....177
- Swing gate [magnet] – Type MFT** ..... 75

- Swing Loader**
- Swing Loader – Type SL-GB .....364
- Swing Loader – Type SL-HBW .....362
- Swivel joint – Type DG-360°** .....174
- System rack – Type SR Highline** .....304

**T –**

- Tools made of stainless steel** .....287
- Top cabinet for changeover bench – Type A-USB** .....207
- Towel dispenser,**
- Towel dispenser, automatic – Type HTSP-E-VA ..... 18
- Towel dispenser, manual – Type HTSP ..... 18
- Transport trolley**
- Transport trolley – Cover transport trolley – Type DW .....348
- Transport trolley – Plates transport trolley – Type TWPE .....348
- Transport trolley – Plates transport trolley – Type TWV .....349
- Transport trough – Type TM** .....337
- Trolley collector – TYPE ROS** .....343
- Trolley**
- Plastic trolley – Type KSR .....342
- Stainless steel steering trolley – Type WRR .....342
- Trolley – Type SGR .....341
- Trolley – Type SLR .....340
- Trolley – Type STR-1 .....340
- Trolley – Type STR-D .....341
- Tub trolley – Type WW-R** .....336
- Turnstile**
- Portal turnstile – Type PDK 1-lane .....73
- Portal turnstile – Type PDK 2-lane .....73
- Turnstile – Type DK-E Ecoline .....72
- Turnstile – Type DK-E Highline .....72

**U –**

- Universal angle bracket – Type KHD** .....182
- Universal dispenser**
- Universal dispenser, automatic – Type USP-E-VA ..... 18
- Universal dispenser, manual – Type USP-A ..... 18
- Universal dispenser, manual – Type USP-L ..... 18
- Universal dispenser – Type USP-O ..... 18
- Universal hose guide – Type USF** .....182
- Utensil dispenser – Type US** ..... 21

**W –**

**Walk-through disinfection basin – Type DDB-S** ..... 45

**Walk-through sole cleaning machines**

- Walk-through sole cleaning machine 1-lane – Type Sole-Star Ecoline..... 54
- Walk-through sole cleaning machine 1-lane – Type Sole-Star Highline ..... 55

**Wall boards**

- Wall board – Type WB-A .....302
- Wall board – Type WB-B.....303

**Wall bracket – Type WH**.....180

**Wall fitting – Type WSS**.....211

**Wall-mounted cabinets**

- Wall-mounted cabinets – Type WS .....272
- Wall-mounted cabinets – Type WS Highline.....274

**Wall-mounted desks**

- Wall-mounted desk – Type WPO.....276
- Wall-mounted desk – Type WPS-I .....277
- Wall-mounted desk – Type WPS-II .....277

**Wall slewing console – Type WSK**.....181

**Wardrobe**

- Wardrobe – Type KG.....214
- Wardrobe – Type KS-S/-W.....215

**Washing systems**

- Attachment rail washing system – Type VSW .....122
- Cabin washing plant – Type KWA-HBW-200/300.....142
- Cabin washing system – Type KWA-DUO, -STB, -RPB .....144
- Cabin washing system – Type KWA-UDT.....150
- Cabin washing system – Type KWA-UGR.....152
- Cover-type washing system – Type HWA Highline.....117
- Feed trolley – pass-through washing system – Type DLWA-HBW.....146
- Large container pass-through washing system – Type DLWA-GB .....148
- Multi tank pass-through washing system for boxes and pallets – Type DLWA 600-2T/2+PAL – 1000-2T/2+PAL Highline.....138
- Multi tank pass-through washing system for boxes – Type DLWA 400-2T – 1000-3T Highline.....132
- Pallet washing system – Type DLWA-PAL .....140
- Pass-through washing system for boxes and baking trays – Type DLWA 250 / 400-Back Highline.....134
- Pass-through washing system for boxes – Type DLWA 180 Ecoline.....124
- Pass-through washing system for boxes – Type DLWA 300 Ecoline.....125
- Pass-through washing system – Type DLWA-A 180 Ecoline .....126

- Rotary basket washing system for customer-specific items to be washed – Type DWA Highline.....118
- Washing systems and their advantages .....128
- Single tank pass-through washing system for boxes and pallets – Type DLWA 300 / 2+PAL – 400 / 2+PAL Highline.....136
- Single tank pass-through washing system for boxes – Type DLWA 200 – 400 Highline.....130
- Smoke stick washing system – Type RSW.....120

**Wash trough – Type WR Highline**.....10

**Water and foam guns**

- Water and foam guns – Type ST .....172
- Water and foam gun – Type ST 3225 Ergo.....173

**Water, foam and disinfectant nozzles – Type WD, SD, SL, DD** .....178

**Water lances – Type WL**.....179

**Water pistols**

- Water pistol, air pistol – Type JET .....173
- Water pistol – Type WP .....172

**Wire-mesh baskets**

- Wire-mesh baskets Enquiry form.....328
- Wire-mesh baskets – Type RSK, RPK.....329

**Workbench trolley – Type WBKW**.....285

**Workbench**

- Workbench – Type WBK-S3L/R .....286
- Workbench – Type WBK-S6 .....286

**Work cabinets**

- Work cabinets Drawer unit left or right – Type AS-SL /-SR.....260
- Work cabinets – Type AS .....256
- Work cabinets – Type AS Highline .....258
- Work cabinets – Type AS-K .....264
- Work cabinets – Type AS-K Highline.....266
- Work cabinets – Type AS-SL/-SR Highline .....262

**Workplace packages**

- Workplace packages – Type Highline SD.....160
- Workplace package – Type Ecoline SE11.....159

**Workshop cabinet – Type ASD-W**.....289

**Workshop trolley**

- Workshop trolley – Type WSW-6L .....284
- Workshop trolley – Type WSW-8Q.....285

**Work tables**

- Work tables as desired by the customer.....254
- Work tables – Double stage work tables – Type DST .....250
- Work tables – Stage work tables – Type SAD .....248
- Work tables – Stage work tables – Type SAH .....246
- Work tables – Stage work tables – Type SAH-H, DST-H.....252
- Work tables – Type AT .....228
- Work tables – Type AT-B, SL, -R.....231

- Work tables - Type ATFI.....238
- Work tables - Type AT-U.....232
- Work tables - Type AT-U, SL, -R.....230
- Work tables - Type UTFI.....240

**MOHN GMBH**

Am Stadion 4  
D-58540 Meinerzhagen

**Telephone** +49 (0) 2354-9445-0

**Facsimile** +49 (0) 2354-9445-299

**Email** [info@mohn-gmbh.com](mailto:info@mohn-gmbh.com)

**Internet** [www.mohn-gmbh.com](http://www.mohn-gmbh.com)



Managing Director: David Mohn

Registration at the commercial register

Register court: Local court Iserlohn

Register number: HRB 3572

VAT ID-No. according to §27 a [German] Value Added Tax Law: DE 196 898 947

**General notes**

Errors, printing errors and technical changes reserved. Article descriptions, illustrations and photos can contain optionally available extras. Reprint as well as all types of electronic processing, storage, publication et cetera are - even in parts - permissible only with written approval of the Mohn GmbH. Our General Terms and Conditions apply. You can view them at [www.mohn-gmbh.com](http://www.mohn-gmbh.com).

Publisher and copyright: Mohn GmbH



