

TUMBLER BT-S

AUTOMATIC VACUUM SALTING SYSTEMS



INOX MECCANICA

Inox Meccanica was founded more than 40 years ago in the area that could be defined as the 'triangle of taste', between Mantova, Bologna and Parma.

Today it has more than 50 employees in the production, administrative, sales, purchasing, warehouse and marketing departments. The activity takes place on an area of about 20,000 square metres, of which over 3,000 are covered.

The growth over the years has been constant, following the expansion of the reference markets; the products have been refined step by step, offering absolutely reliable and very high quality equipment. In addition to more traditional machines such as **stuffing machines** and **automatic clipping machines**, we have added other technological solutions of absolute importance such as **vacuum salting systems**, **industrial washing systems**, **automatic packaging lines** and **consumables** such as **clips**, **loops** and other exclusive materials.

The real 'beating' heart of the company is our **technical department**, a true engineering sector, which, gathering information and indications from the sales and marketing sector, designs increasingly evolved solutions capable of satisfying the growing needs of the food sector.



TUMBLER BT-S

Technology applied to these equipment is the result of continuous studies and experiments that the R&D department of Inox Meccanica has developed over the past 15 years.

The process developed by Inox Meccanica makes it possible to **switch from a static to a dynamic system** which involves that allows allows **shortening salting times, minimising labour force** employed, **obtaining a product with a high salting homogeneity, minimizing the risks of environmental contamination** as much as possible and **obtaining a high quality product through an industrial process** that guarantees a constant result.

We produce automatic vacuum tumblers with load capacities of 500, 1200, 2000, 3000, 4000 and 5000 kg approx. for **products to be cured** such as **hams, bresaola, speck, pancetta, coppa** and **loins**.



 INOX MECCANICA
TECNOLOGIA PER LA SALUTE



ADVANTAGES OF OUR TECHNOLOGICAL SOLUTIONS

- ⊙ Drastically shorten salting times;
- ⊙ Minimising labour force employed
- ⊙ Not necessarily highly specialised staff;
- ⊙ Obtaining a product with a high salting homogeneity;
- ⊙ Minimize the risks of environmental contamination as much as possible;
- ⊙ **Obtaining a high quality product through an industrial process that guarantees a constant result.**



VACUUM SALTING SYSTEMS

BT-S TUMBLER

WATCH THE VIDEO





INOX MECCANICA
TECNOLOGIA PER LA FOOD MECCANICA

INOX MECCANICA



OUR PRODUCTION CYCLE

The Inox Meccanica automatic salting cycle consists of a series of technological actions to which the product is subjected:

- ⊙ Salt distribution
- ⊙ **Osmotic action**
- ⊙ Homogenization
- ⊙ Liquid extraction
- ⊙ Rest in the atmosphere or in a vacuum
- ⊙ Atmospheric or vacuum massage

For each different technological action, our salting machine automatically prepares itself to carry out this action. At each pre-set action, the churn performs a series of rotations, tilting, stops either in atmosphere or in vacuum.

The order and duration of these pre-set actions are the result of the experimentation carried out in our technological laboratory.

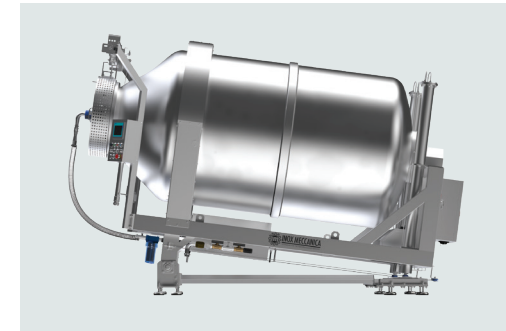





OSMOTIC EXTRACTION

WATCH THE VIDEO

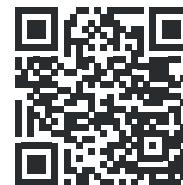

HOW OUR PROCESS TAKES PLACE

One of the most important advantages of our technology is the **salting process through osmotic extraction**.

The absorption of salt by the meat involves water outflow (rich in salt and ingredients) which, by exploiting the rotation and tilting movement of the machine, homogenises the salt and other ingredients on the product.

Once the concentration of salt in the water, which has formed inside the tumbler, has reached a percentage of approximately 10%, a patented automatic system drains the water.

This step takes place during the first 12 hours of the process.



INTERNAL BLADE

The blade, which has been designed for cured products, performs a gentle massage that distributes and mixes all the ingredients precisely and uniformly.



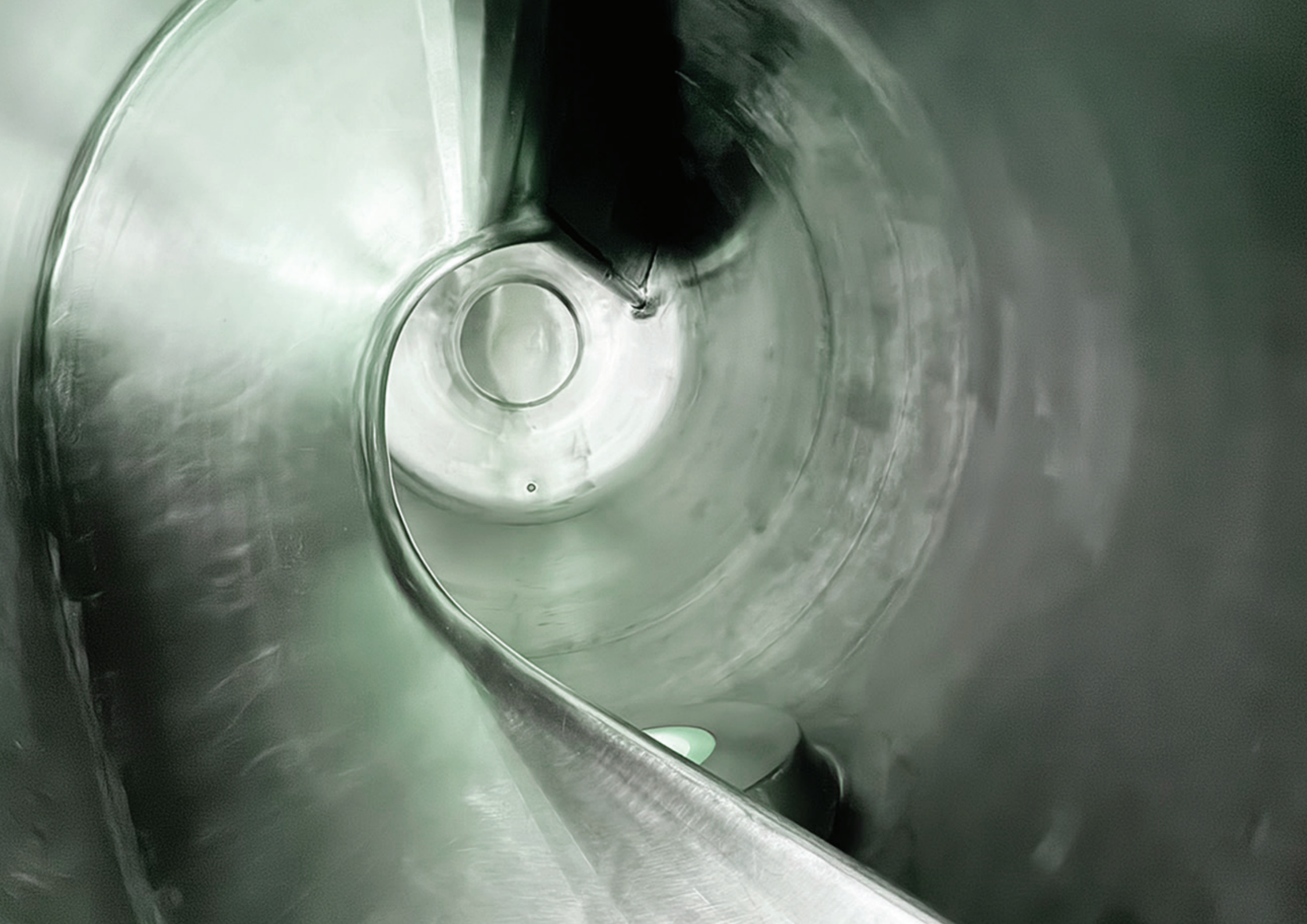



INOX MECCANICA TECHNOLOGY

AUTOMATIC INGREDIENTS LOADER

WATCH THE VIDEO



AUTOMATIC SYSTEM FOR LOADING SALT AND INGREDIENTS

This special system allows salt and all other ingredients to be automatically loaded into the tumbler through the closing hatch.

Un tubo opportunamente sagomato viene inserito al centro del boccaporto e, sfruttando il vuoto creato all'interno della botte, le polveri vengono risucchiate dal contenitore, in cui sono contenute, e trasportate pneumaticamente all'interno.

I vantaggi principali di questo sistema sono:

- ⊙ optimal salt distribution;
- ⊙ salt loading speed;
- ⊙ safety for the operator, the dispersion of dust into the environment is avoided, eliminating the risk that it may be inhaled by the staff.



A grayscale photograph of industrial machinery, likely a tumbler, with a prominent logo on a curved surface. The logo consists of a gear icon containing the letters 'im', followed by the text 'INOX MECO' and 'TECHNOLOGY FOR THE FOOD PRO' below it. The machinery is supported by a metal frame.

SAFE AND RELIABLE MOTORISATION

1. Safe chain transmission without slippings;
2. Energy recovery by high-efficiency inverters and motors of Siemens using the second part of rotation with the blade acting as driving force;
3. Tumbler's support wheels made of special plastic material with long duration bearings;
4. Vacuum system with antidust filters;
5. Rear hydraulic lifting system.



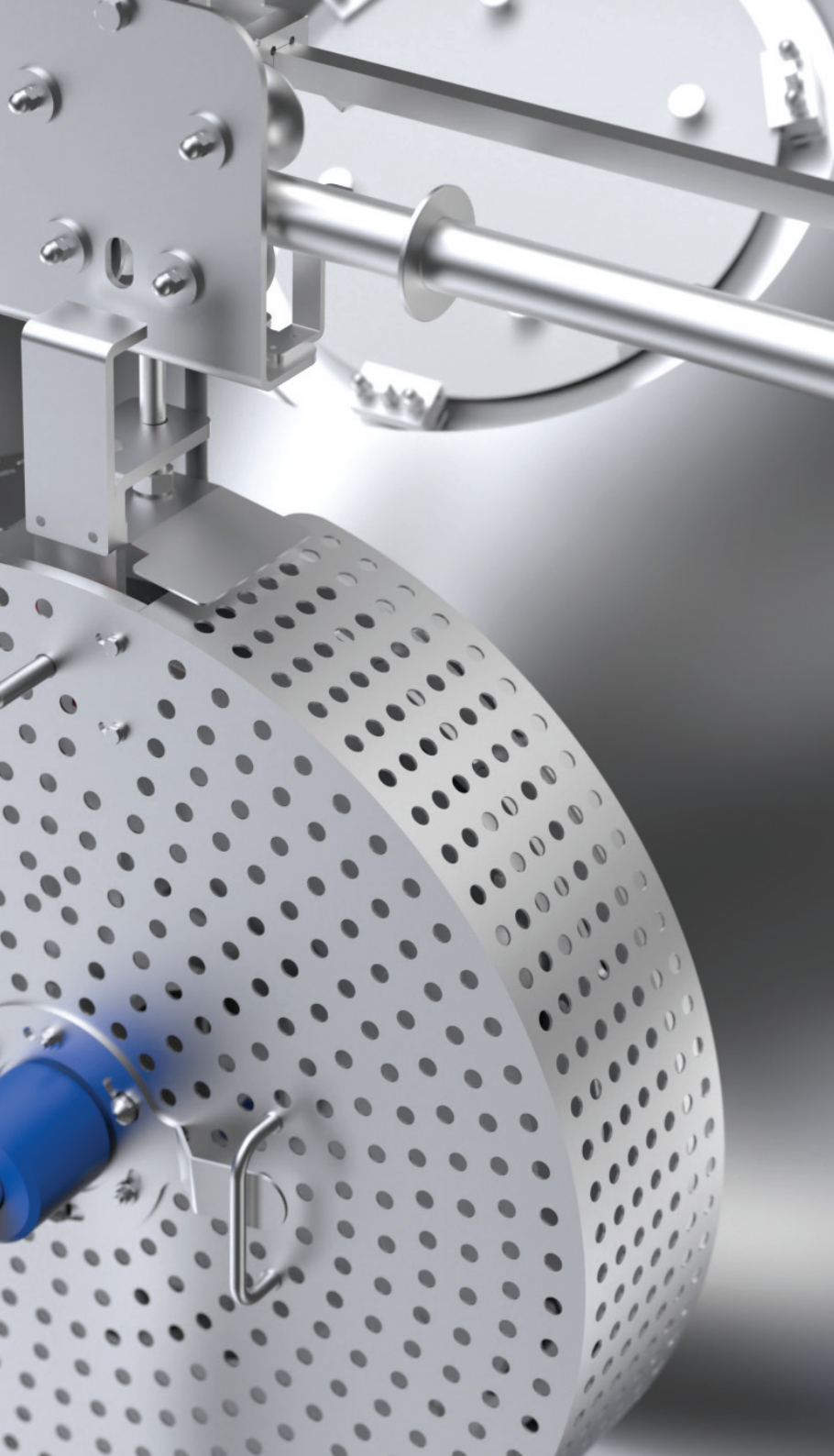

HYGIENE AND TECHNOLOGICAL INNOVATION

Inox Meccanica technicians have developed a hatch with a silicone gasket certified for food contact and with the following features:

- ⦿ The gasket is press-fit into the groove;
- ⦿ It does not allow any dirt intrusion;
- ⦿ It does not need to be dismantled for washing and sanitising operations;

Furthermore, the hatch is complete with an innovative closing system that guarantees maximum tightness of the tumbler both under pressure and vacuum.

The additional hatch is positioned on the tumbler's cone to allow complete cleaning of the hidden areas behind the shovel.

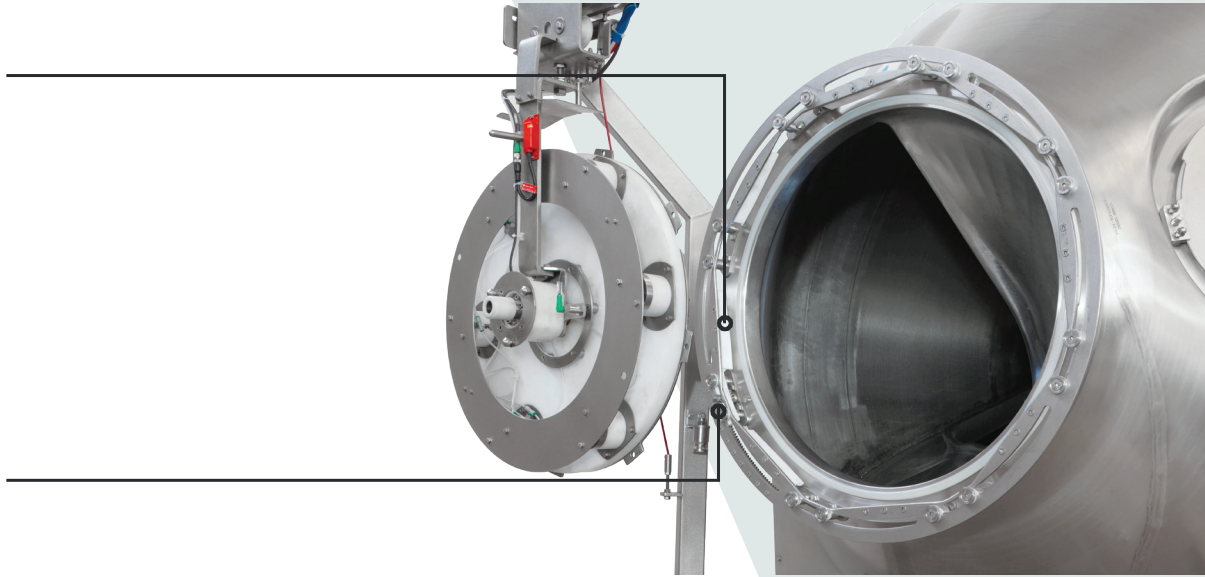
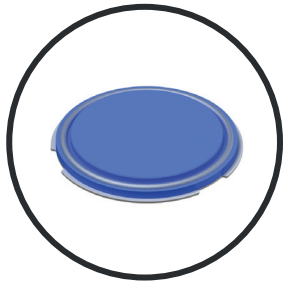



CONTROL PANEL AND ELECTRONICS

Interface, communication and service:

- ⊙ Stainless steel push-button panel with push-buttons approved for the food industry with a high degree of protection (IP66);
- ⊙ Intuitive and fast touch screen control panel with powerful software that allows to set up the recipes quickly and easily;
- ⊙ Using a special application installed on one of the company's PCs, one of your operators will be able to virtualise the machine's panel, view and edit recipes in total comfort;
- ⊙ All phases can be individually configurable: time, speed and vacuum percentages;
- ⊙ Router for network connection and remote assistance;
- ⊙ Remote control with SISTEMIX, an innovative supervision and interface system between PC/tablet and Tumbler's PLC;
- ⊙ Siemens PLC / operator panel and all components of the switchboard guarantee quality and reliability;

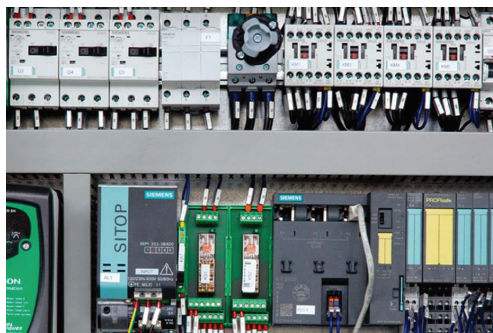



COOLING SYSTEM

- ① Cooling system with glycol circulation in the external cavity of the tumbler, so that the machine can be directly installed in a production unit, keeping the temperature of the product under control while it is being processed;
- ① Product temperature control system inside the barrel via wireless temperature probe.

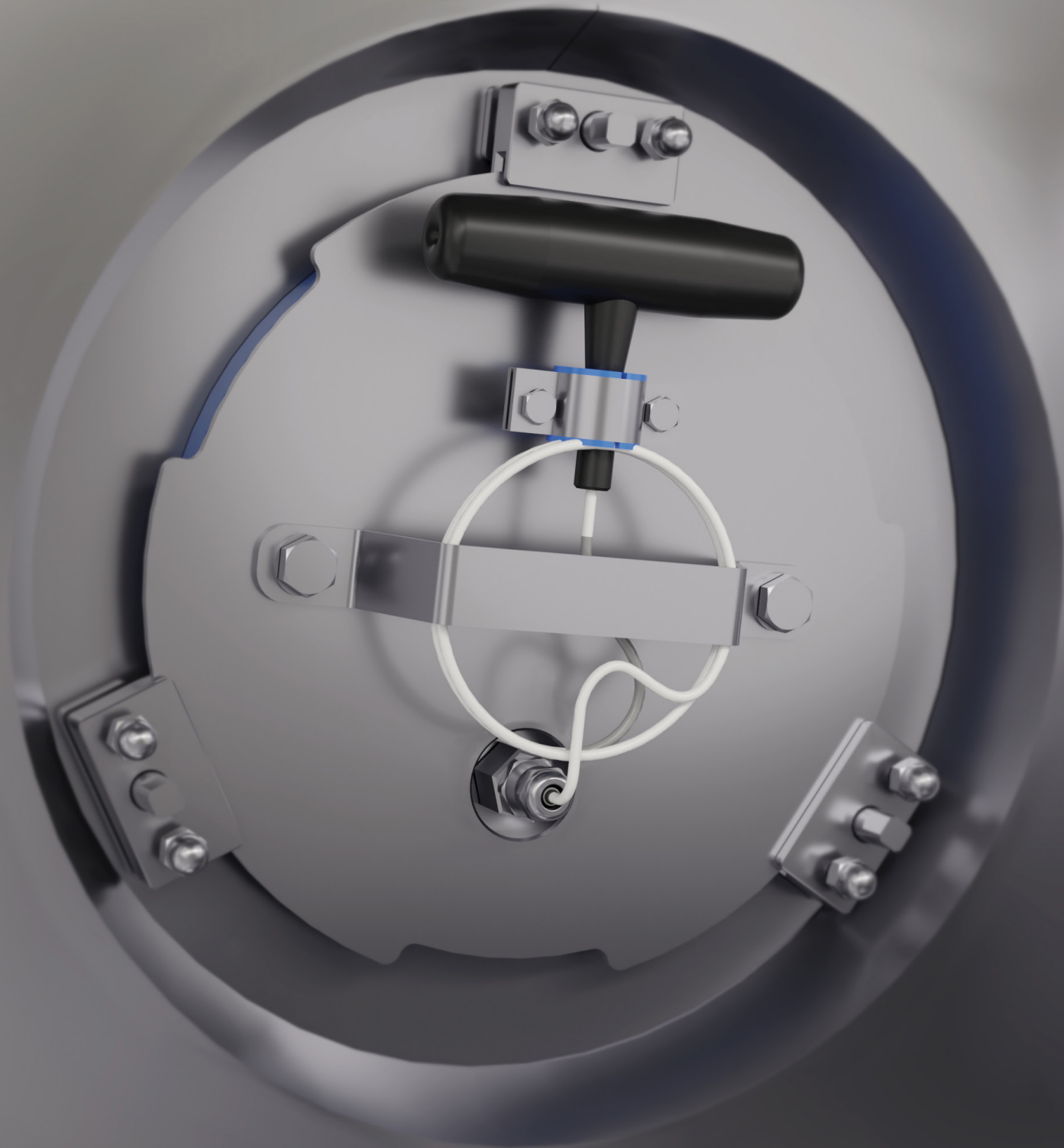

PRODUCT WEIGHT CONTROL

Inox Meccanica Tumblers can be equipped with stainless steel loading cells with relevant display for weight visualization and setting , in order to check and control the quantity of product loaded or relevant additions.







SYSTEM X

Thanks to its structure, the web supervision system allows, with the simple installation of the server, to be able to access via web and from any device, without the need to install any additional software.

The software provides user access management through a secure login with encrypted passwords and access levels predetermined by the system administrator, this to ensure access security, data protection and traceability of actions with logging of every single change made to the system. from management parameters to recipes.

Sending, editing, archiving and receiving of each single phase (25 total phases per recipe) for each of the 50 recipes present in each of the machines with constant monitoring and display.

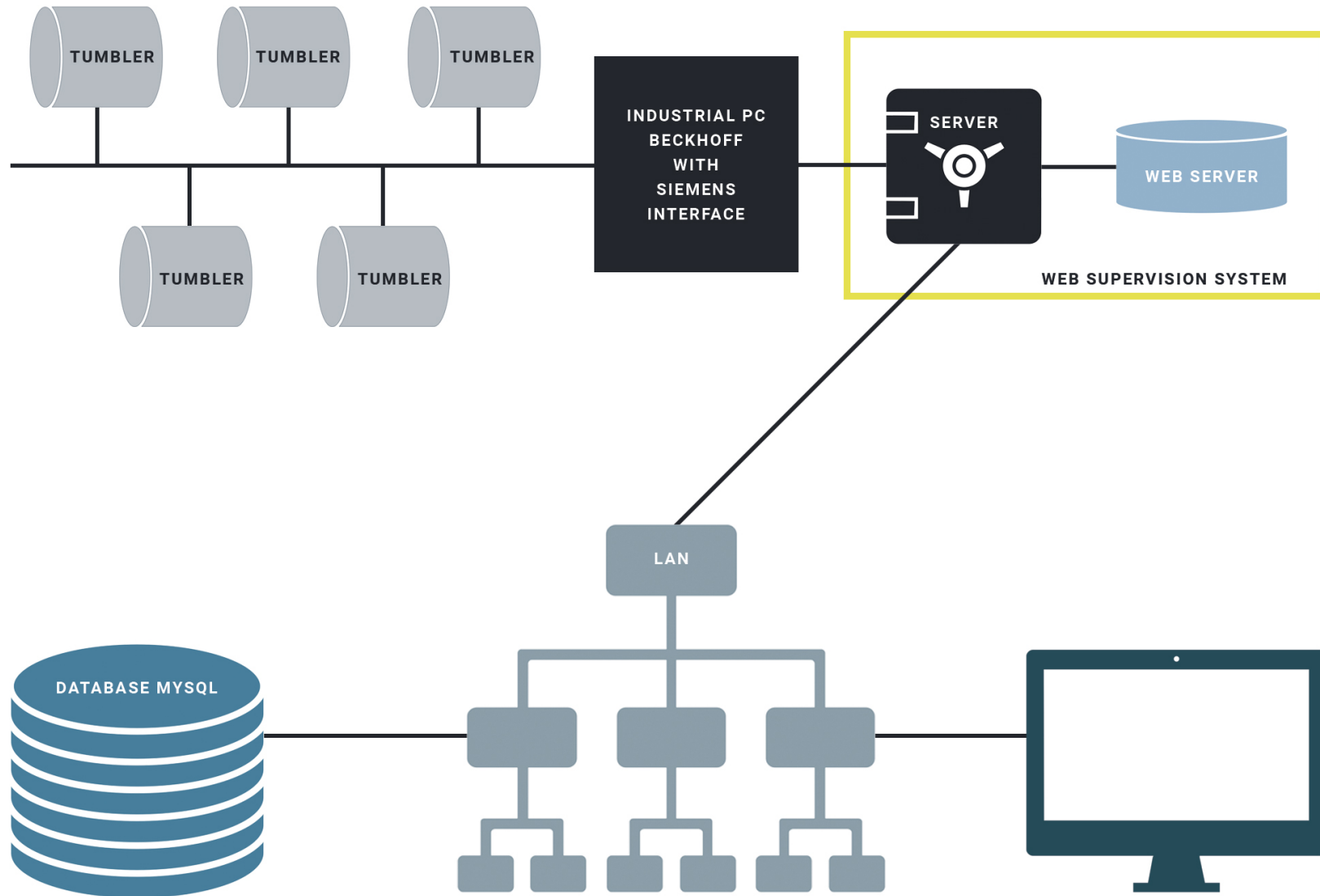



 **INOX MECCANICA**
TECHNOLOGY FOR THE FOOD PROCESSING INDUSTRY

ACCESSORIES

To improve your automations and make your salting process faster and more complete we have developed various accessory machines including...



SUPERMIX 100



LOADING CONVEYOR BELT



COLUMN ELEVATOR TIPPER ON RAIL

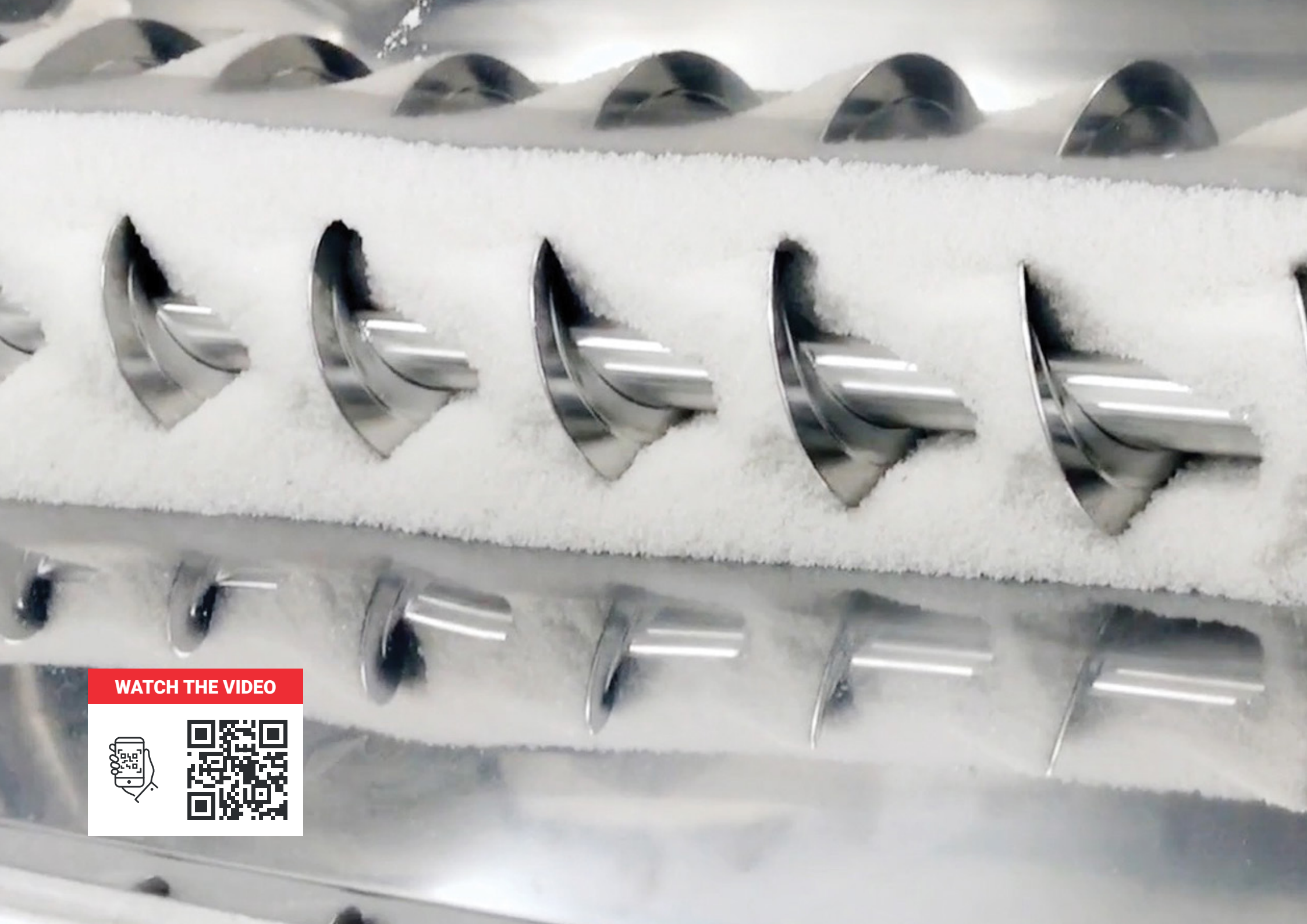

WATCH THE VIDEO



SUPERMIX 100

The Supermix 100 is a salt and aroma mixer with the following advantages:

- ⊙ Guarantees a homogeneous blend;
- ⊙ Easy cleaning and washing for changing ingredients;
- ⊙ Load capacity of about 100 Kg.

The stainless steel screw can be easily disassembled for cleaning. Inside the housing of the auger, a special gasket is inserted that prevents the product from leaking out during the mixing phase. The loading door is hinged to the structure and, through a sensor, guarantees the operation of the machine only when it is correctly closed. A polycarbonate porthole is also applied to the door for internal inspection during operation.

To unload the product at the end of the cycle, a manual shutter is used, located in the lower part of the containment hopper.

To unload the product at the end of the cycle, a manual shutter, located at the bottom of the hopper, is used.



LOADING CONVEYOR WITH MODULAR BELT

To facilitate the product loading phase, it is possible to use a modular plastic loading belt equipped with special flights.

The belt is also equipped with wheels to be moved within the department from one machine to another and manually adjustable load height.

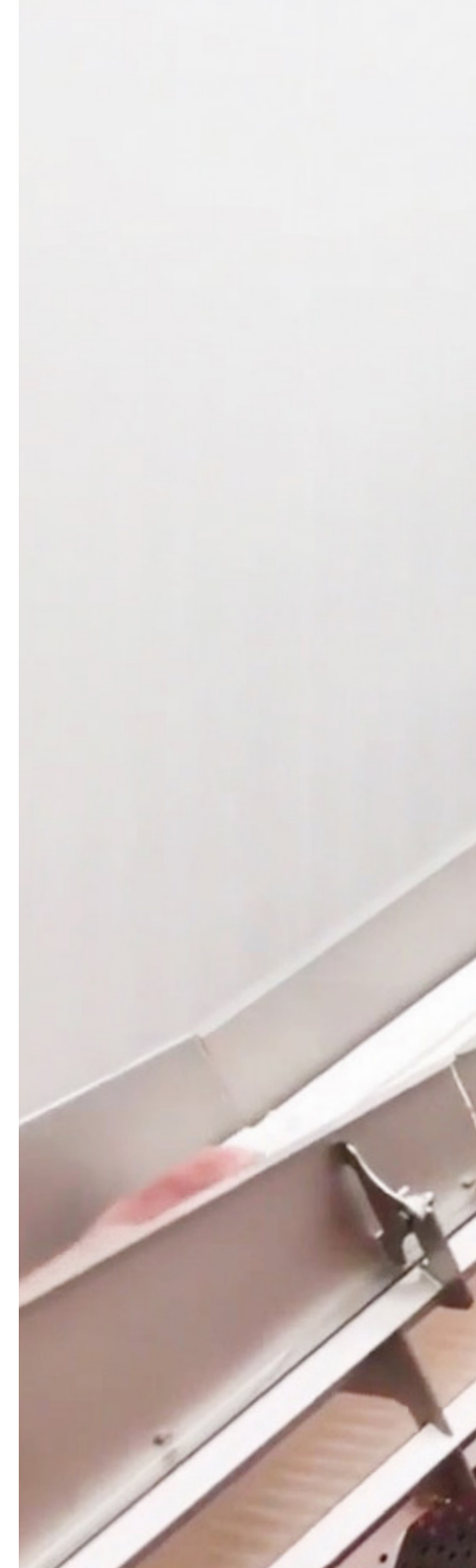

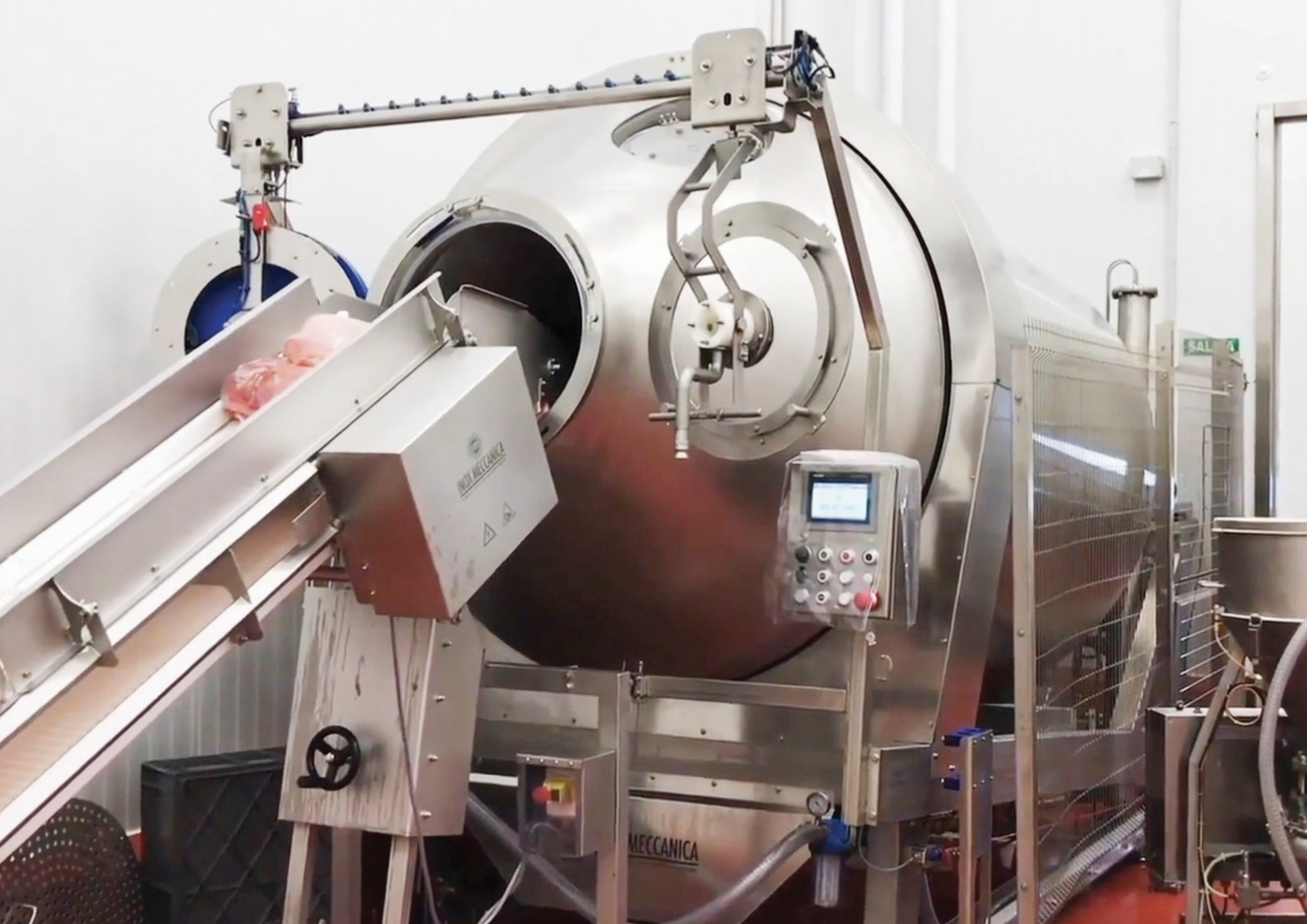

INDIA MECCANICA

MECCANICA

SAL 4



WATCH THE VIDEO



ELEVATOR TIPPER ON RAIL

The machine is made up as follows:

- ① Main frame on which the lifting columns are installed;
- ① Motorised central unit for lateral movement of the loader from one churn to another;
- ① Movable meat hopper so that once in place, it can fit inside the loading hatch;
- ① Proximity sensors that guide the movement of the loader by stopping it in a frontal position at each churn.



The background features a white field with two large, overlapping geometric shapes: a red triangle pointing downwards from the top-left corner, and a black triangle pointing upwards from the bottom-left corner. The two triangles meet at a sharp point in the center-left area.

TECHNICAL DATA & LAYOUT

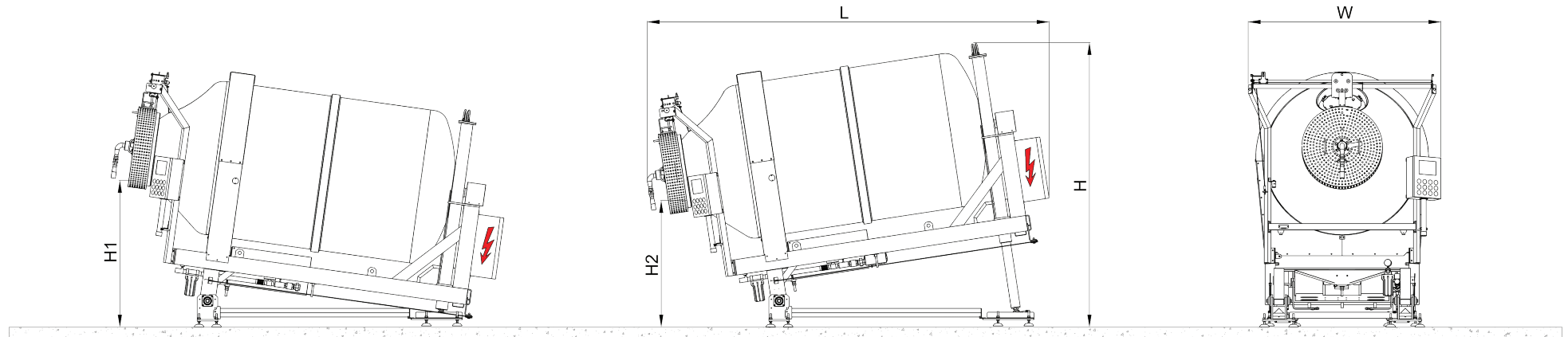

Model	Capacity (max. in Kg.)	W (in mm.)	L (max. in mm.)	H (max. in mm.)	H1	H2
BT-S 1000	500	1830	2965	2330	1025	900
BT-S 3000	1500	1775	3380	2390	1370	1230
BT-S 4000	2000	1885	3910	2765	1425	1230
BT-S 6000	3000	2050	3914	2786	1425	1228
BT-S 9000	4500	2175	4933	3340	1755	1470

REMOTE SUPPORT

We offer our customers an **integrated connectivity system** where functionality and user-friendliness find the perfect balance.

Each Inox Meccanica machine can be equipped with a router that allows us to provide timely and often decisive remote support.

Our machines are designed to communicate remotely with our **Service Department** and are equipped with software that can interface with the customer's plant management system.





More than 100 customers
worldwide have chosen our
automatic salting systems!
Find out why...



- ⊙ It ensures an even distribution of salt on the product;
- ⊙ Optimal conditions for salting are created inside;
- ⊙ The product is not exposed to contamination from the external environment;
- ⊙ The blade is specially designed to gently massage the product while preserving its integrity;
- ⊙ It is equipped with an integrated rear lifting system that allows product remixing during the operating cycle, optimising process efficiency and facilitating product discharge at the end of the cycle;
- ⊙ The rotation speed can vary from 1 to 3 revolutions per minute depending on production requirements;
- ⊙ It uses a vacuum system that allows the intensity to be varied according to the various phases of the salting cycle;
- ⊙ The patented osmotic hatch allows the controlled escape of liquids, while ensuring maximum tightness of the tumbler;
- ⊙ The chain drive guarantees slip-free rotation and is more durable;
- ⊙ Thanks to a glycol circulation system, positioned in the cavity of the tumbler, it is possible to control the temperature of the product while it is being processed, avoiding the need to place the tumbler inside a cold room;
- ⊙ Thanks to the load cells, it is possible to check the exact quantity of product loaded into the tumbler.



Inox Meccanica S.p.A.
Strada Solarolo, 20/B-C-D
46044 Solarolo di Goito
Mantova - Italy

web. inoxmeccanica.com
email. info@inoxmeccanica.it
tel. +390376608282

