

REX
TECHNOLOGIE®

VACUUM FILLER &
PORTIONING SYSTEMS



Sausage filling
and hanging line

LD

80

S

RKS

85



RKS 85 - the calibration genius

The REX RKS is the universal solution for precise calibration of all types of artificial, collagen and natural casings and is flexible enough to be integrated into all processing solutions. It has been designed to meet the needs of processing units of different sizes. Calibration is all about achieving the exact length and weight required. This is the basis for efficient production. The easy changeover from natural to artificial casings (or vice versa) is another basis for efficient and versatile use.

The sausages twisted off by the holding device are transferred directly to the two conveyor belts of the RKS. This optimises the twisting process and minimises waste due to casing bursting. The conveyor belts are height-adjustable and can therefore be easily adapted to all casing calibres. The RKS calibrates the casings to the desired diameter, ensuring that sausages are produced with the same weight and length. This improves product quality and helps you achieve your desired quality criteria.

The benefits at a glance:

- Maximum product weight accuracy
- Identical length for natural casing applications
- Wide range of applications
- Gentle twisting of casing, therefore less waste
- Shortest set-up times
- Efficient operation

The RKS is equipped with servo motors that are set and monitored via the filling machine's touch-screen controller. Belt speeds are automatically adjusted to suit the product and portion size. This guarantees the shortest possible changeover times. After transport, the calibrated sausage chain is transferred in a controlled manner to the RHS, which hangs it directly on hooks. From there the sausage can be removed with a smoke stick.

Other features of the RKS are:

- Easy operation and adjustment of the system
- Unique hygienic design for quick and easy cleaning
- Can be used with artificial, collagen and natural casings
- Can be connected to all RVF 400S, 700 & 900 series fillers
- Reliability through quality

Perfect calibration of artificial and natural casings



Gentle casing linking, versatile application



Optimised linking process

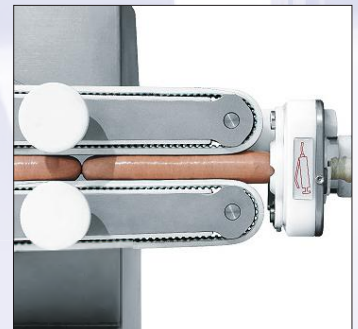

**0
3
2
RHS**



RHS 230 - makes hanging easy

The REX Calibration System in combination with the Hanging System is the universal process solution for hanging all types of natural, collagen and artificial casings and ensures efficient calibration and hanging of the linked sausage chains. In this combination, it is considered the entry level model of the REX casings systems and is used in industrial applications as well as in medium and small businesses. The calibration system is connected to the casing holder of the vacuum filler. The sausages linked by the holding device are directly calibrated in length by the conveyor belts of the calibrating system, from where the linked sausage chains are directly transferred by the catch hooks of the hanging system and hung up for easy removal with the smoke stick.

The hanging system is available in two different heights and therefore with different hook heights. The control and monitoring of the parameters is done via the touch screen on the vacuum filler. The required parameters can be easily adjusted to suit the product and portion size. This ensures the shortest possible changeover and set-up times. Depending on the casing length or product diameter, different groups with different numbers of hooks can be stored in the touch-screen control for specific programmes.



Versatile application



Economical twisting off of artificial casings



Gentle transfer of casings to the hook

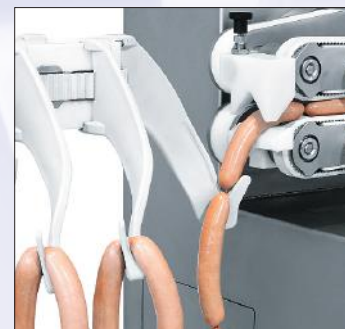

Characteristics of the RHS manual hanging system:

- Highest product weight accuracy
- Can be used with natural, collagen and artificial casings
- Same length for natural casings
- Wide range of applications
- Casing-friendly linking, therefore less waste
- Shortest set-up times when changing products
- Can be connected to all filling machines in the RVF 400S, 700 & 900 series

AKS 65



Industrial sausage production with REX linking and hanging technology

REX linking and hanging technology stands for maximum flexibility. The processing solution is innovative with the highest productivity and flexibility for all types of sausage. Whether you process natural, artificial or collagen casings, the hanging systems fill to the exact portion size at maximum speed.

The filling process is carried out by the REX vacuum filler. The product is gently conveyed by the vane cell feed system and the residual air is evacuated to the maximum. This provides the basis for the product quality of your sausages.

AKS 65 - semi-automatic casing change using turret technology

In the AKS 65 version without casing magazine, the casing is fed manually onto the linking nozzle.

The casing is mounted on the twist-off tube, especially for natural casings, but also for all artificial and collagen casings. The casing is changed by simply activating the 2-hand condition on the AKS 65. This guarantees the shortest possible casing changeover times for the highest production output using a 3-way nozzle, minimising downtime.

In voider mode, the filling process is continuous, with the voider defining the linking point and thus the portion of equal lengths, accurate to the gram. However, it is also possible to switch to start/stop mode for special large-calibre natural casings applications.

Calibration belts ensure precise lengths

The two calibration belts, which operate on the displacement principle, complete the concept. They can be easily adjusted to the calibre range by turning the two adjustment screws. This ensures flexible use for all types of cases with different case diameters. It also reduces set-up times to a minimum. The traversing motion and belt speed are automatically controlled by the vacuum filler's control system.

Fast casing change with the 3-way turret



Flexible use for all casing types and diameters



Displacement system defines the portion length



AKS 65M

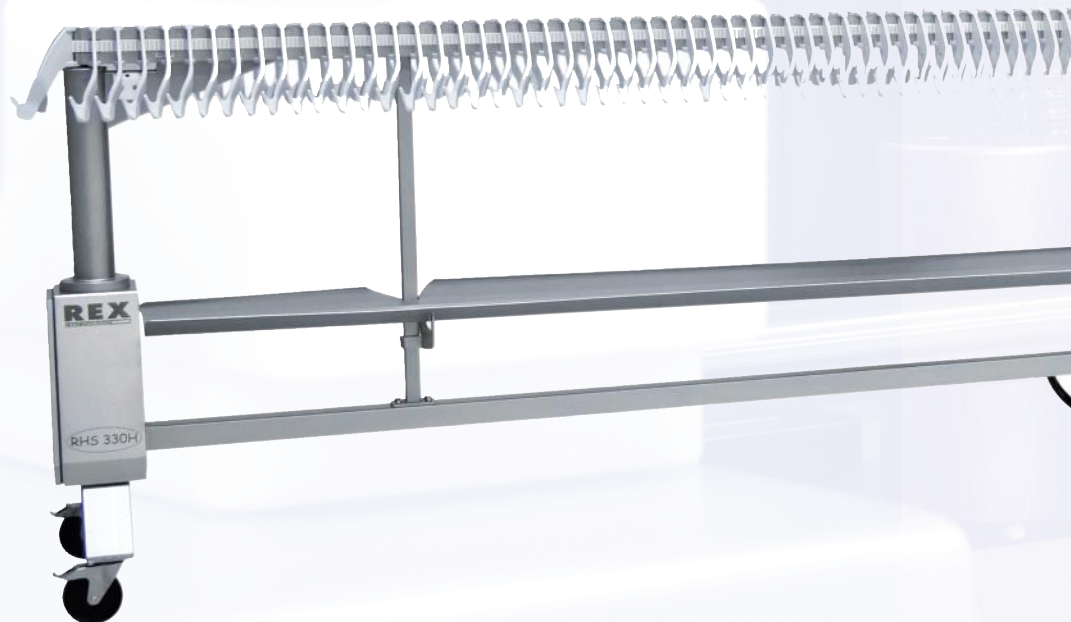

Industrial sausage production with REX linking and hanging technology

REX linking and hanging technology stands for maximum flexibility. The processing solution is innovative with the highest productivity and flexibility for all types of sausage. Whether you process natural, artificial or collagen casings, the hanging systems fill to the exact portion size at maximum speed.

The filling process is carried out by the REX vacuum filler. The product is gently conveyed by the vane cell feed system and the residual air is evacuated to the maximum. This provides the basis for the product quality of your sausages.

AKS 65M – fully automatic casing change for all artificial and collagen casings

The AKS 65M is perfectly matched to the RHS hanging system for fully automatic sausage production. The casing is automatically fed from the casing magazine onto the linking nozzle. The revolver technology, equipped with three linking tubes, guarantees a casing change less than 2 seconds. The AKS 65M can also be operated without the casing magazine and the casing can be manually loaded onto the linking tube, especially for natural casing applications, but also for all artificial and collagen casings. The linking tubes are available in two different lengths, 330 or 430 mm.

The casing can be changed by simply activating the two-hand condition on the AKS 65. This ensures the shortest possible casing changeover times for maximum production output using a 3-nozzle turret, minimising downtime.

When operating with voiders, the filling process is continuous, with the voider defining the linking point and thus the portion to the gram for equal lengths. However, it is also possible to switch to start/stop mode for special large-calibre natural casings applications.

Calibrating belts ensure exact lengths

The two calibrating belts after the voider system complete the concept. They can be easily adjusted to the calibre range by turning the two adjusting screws. This always ensures flexible use for all types of casing with different casing diameters. Furthermore, the set-up times are reduced to a minimum. The traversing movement and belt speed are automatically controlled by the control system on the vacuum filler.

Automatic casing magazine



Maximum production output thanks to revolver technology



Voider system defines the portion length



RHS 330 / RHS 235

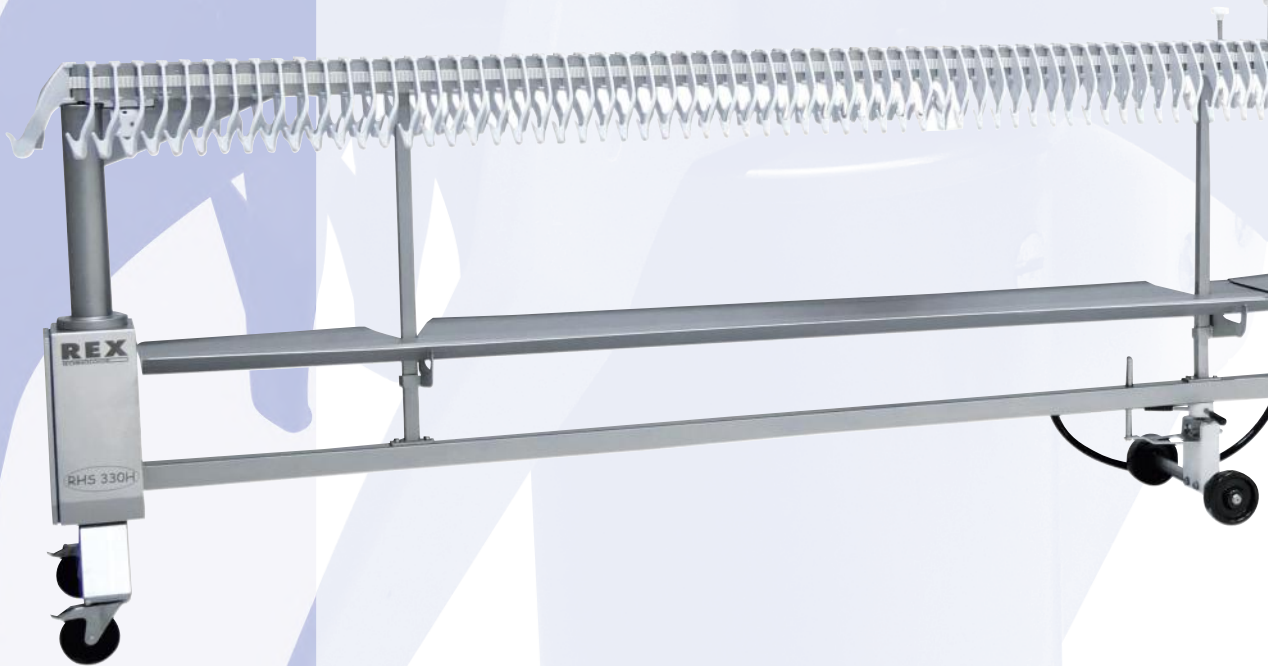

The hanging system makes hanging easy

The AKS 65 transfers the linked sausage chain directly to the hooks of the hanging system. Whether the sausage chains are straight or curved, the AKS's calibrating belts accurately transfer the linking position to the hooks. The number of pieces per 'loop' on the hook, as well as the groups, are set and stored in the vacuum filler's product programme.

The tight pitch of the hooks ensures maximum loading of the smoke stick and therefore the smoking and cooking system. As with the AKS 65, the REX hanging system can be adapted to the operator's height by increasing the working height.

Seamless transfer of the sausage chains

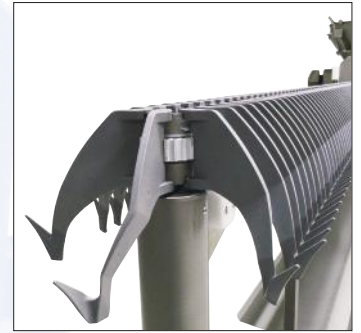

Optional increase in the working height



Precise transfer to the catch hooks



Features of the industrial hanging system:

- Highest product weight accuracy
- Can be used with natural, collagen and artificial casings
- Same length for natural casings
- Wide range of applications
- Gentle on the casing, therefore less waste
- Shortest set-up times for product changes
- Can be connected to all REX vacuum fillers of the RVF 400, 700 & 900 series

Technical data RKS & RHS 230

Filling machine types	RVF 400S, 700 & 900
Portioning speed	up to 550 portions/min
Type of casings	all artificial, collagen and natural casings
Calibre range	13 to 50 mm
Length of portions	from 25 to 600 mm
Types of holding devices	DHG 400
Length of linking devices	400 mm
Compressed air connection	400 V / 50 Hz, 1,5 kW
Connection	directly to the RKS 85 / 95 or DHG 400 of the RVF 400, 700 & 900
Number of hooks	120 pieces, can be plugged in variably
Height of hooks RHS 230	998 mm
Height of hooks RHS 230H	1198 mm
Smoking stick lengths	2 smoking sticks up to 1050 mm
Connected load	400 V / 50 Hz, 1,5 kW
Net weight RKS 85	178 kg
Net weight RKS 95	190 kg
Net weight RHS 230	135 kg
Net weight RHS 230H	140 kg

Scale drawing RVF 400 + RKS 85

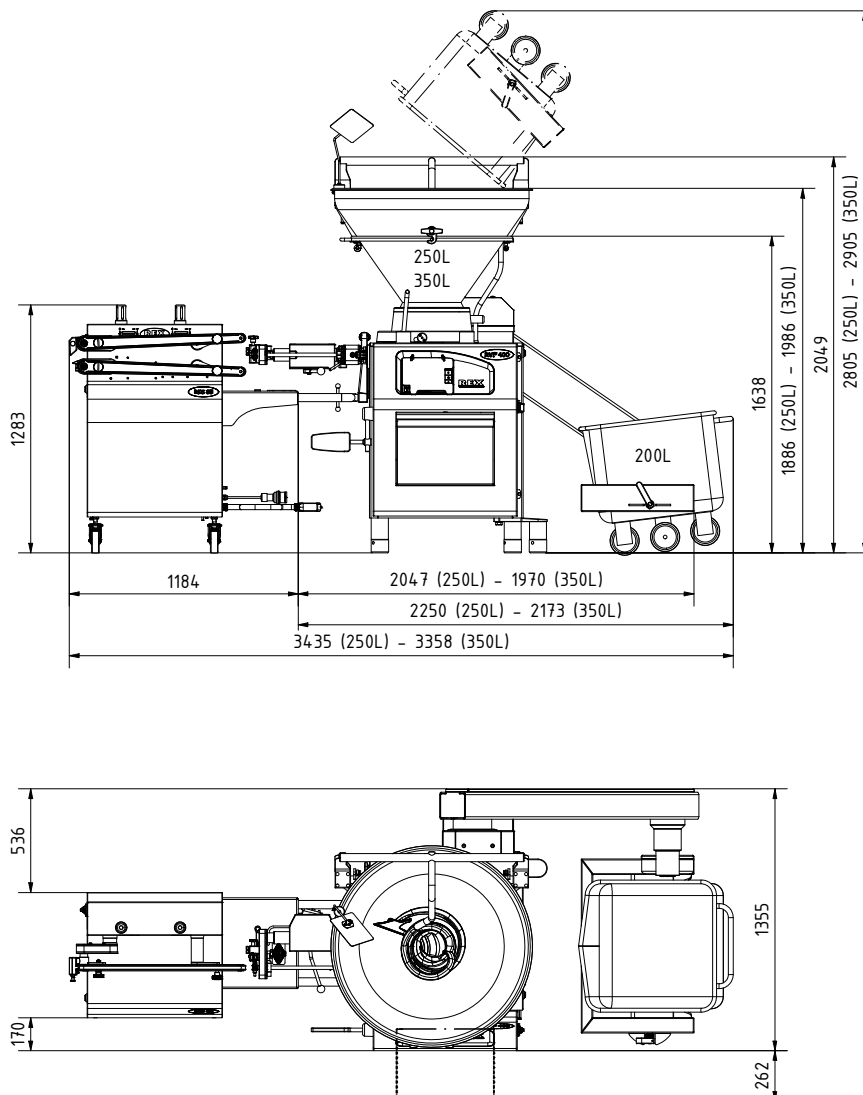

Scale drawing RVF 400 + RKS 85 + RHS 230

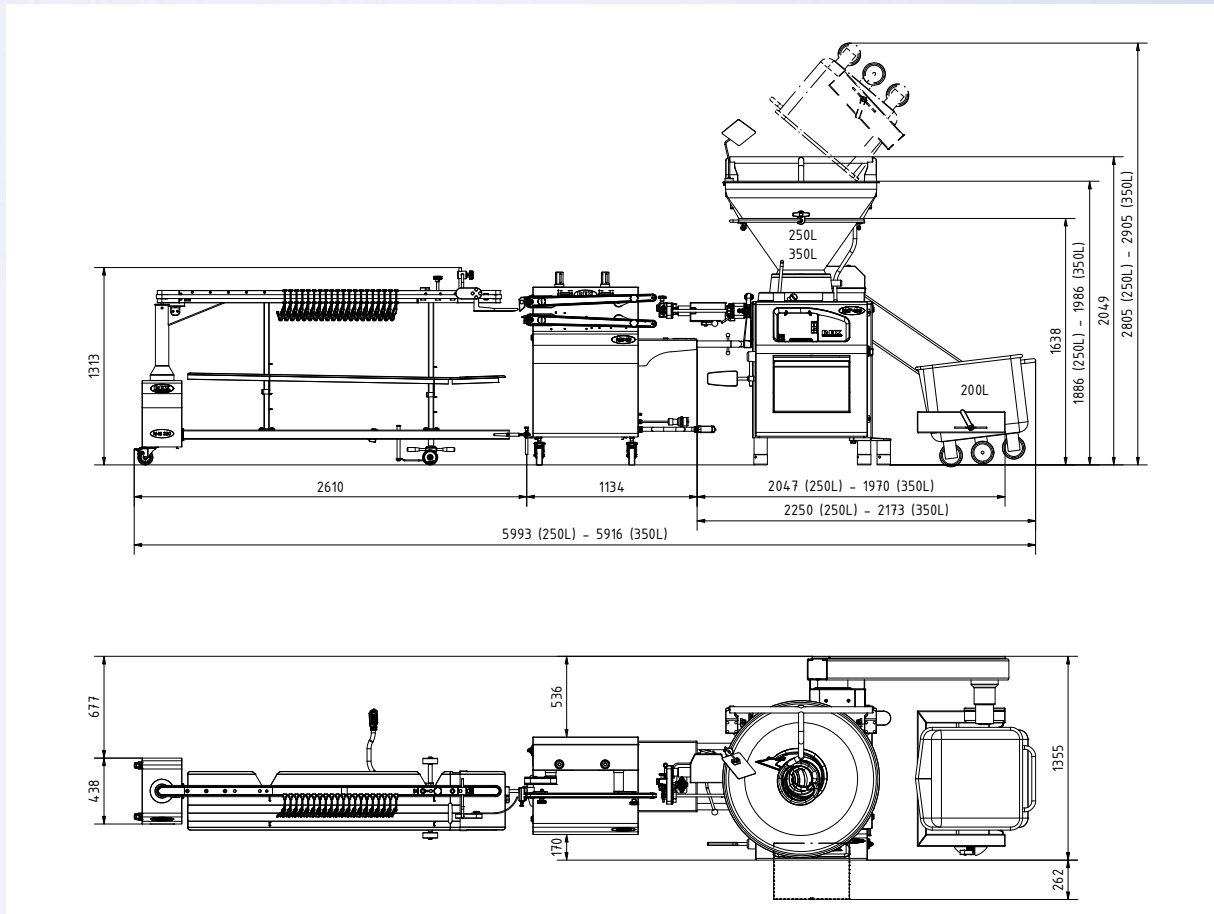

Scale drawing RVF 700 + RKS 95H + RHS 230H

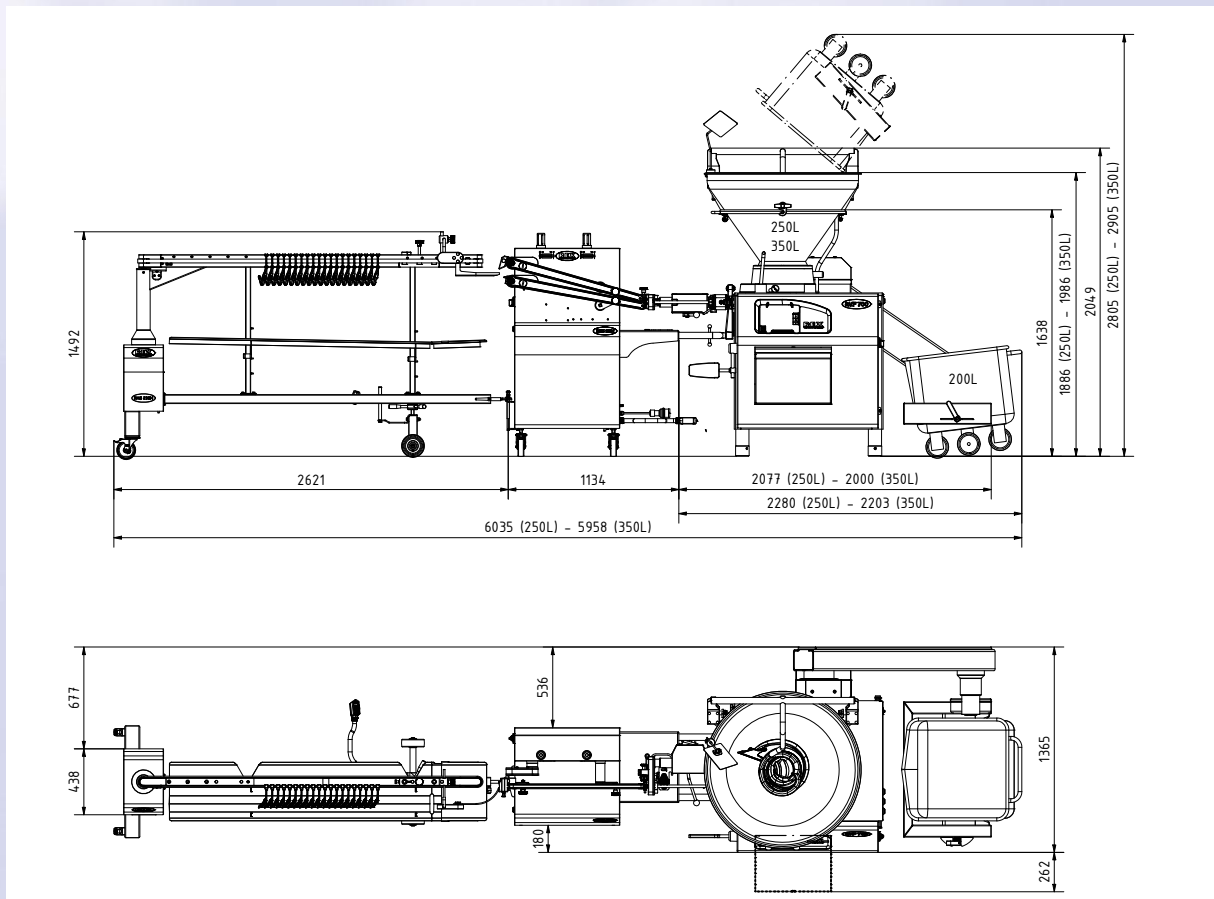

Technical data AKS & RHS

Filling machine types	RVF 400, 700 & 900
Portioning speed	up to 2.500 portions/min
Type of casings	all artificial, collagen and natural casings
Calibre range	13 to 50 mm
Length of portions	from 25 mm
Length of twisting pipes	430 mm / 530 mm
Usable length of twisting pipes	330 mm / 430 mm depending on casing type
Water consumption	70l/h at 5 bar
Air consumption	25l/min. at 6-8 bar
Connected load	380-400 V / 50 Hz/60 Hz, 6 kW
Net weight AKS 65	660 kg
Net weight AKS 65M	810 kg
Net weight RHS 235 (H)	175 kg
Net weight RHS 330 (H)	180 kg
Number of hooks RHS 235 (H)	160 pieces, variably pluggable
Number of hooks RHS 330 (H)	221 pieces, variably pluggable
Hook height RHS 235 / 330	935 – 1012 mm
Hook height RHS 235H / 330H	1088 – 1165 mm

■ Scale drawing RVF 700 + AKS 65M

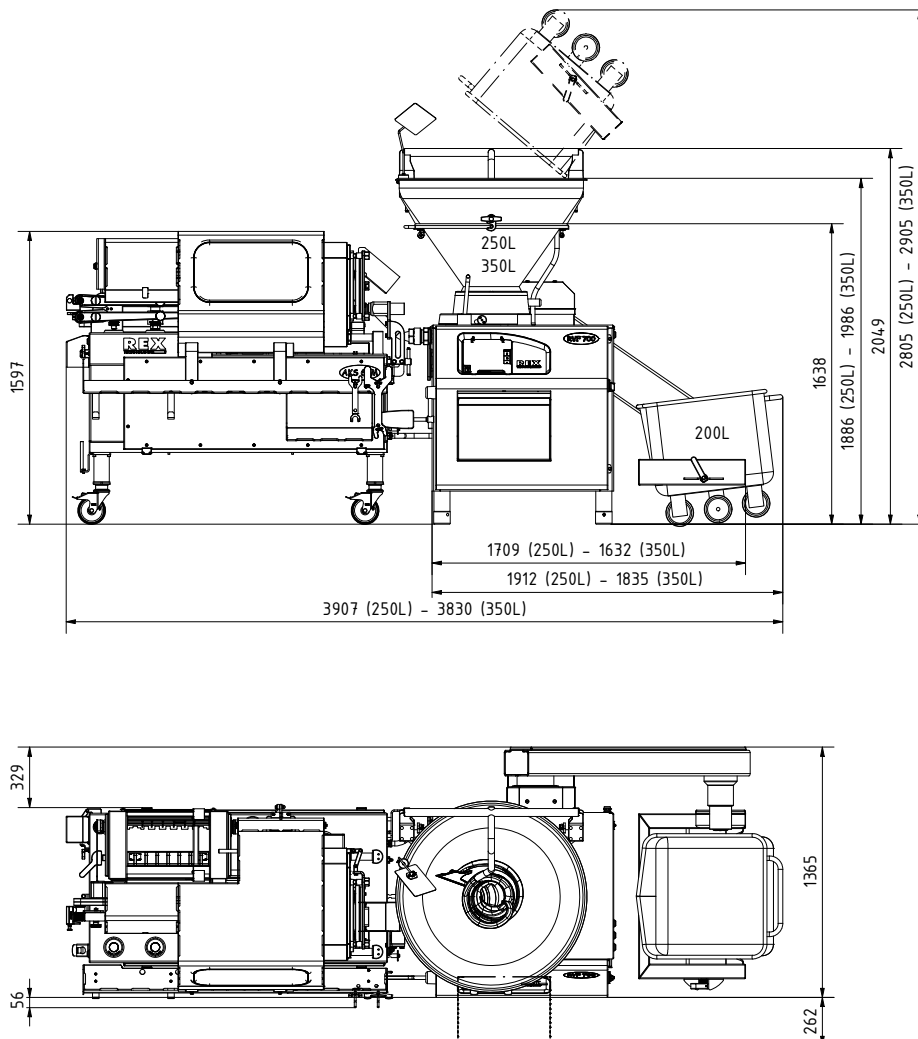

Scale drawing RVF 400 + AKS 65 + RHS 330 / RHS 235

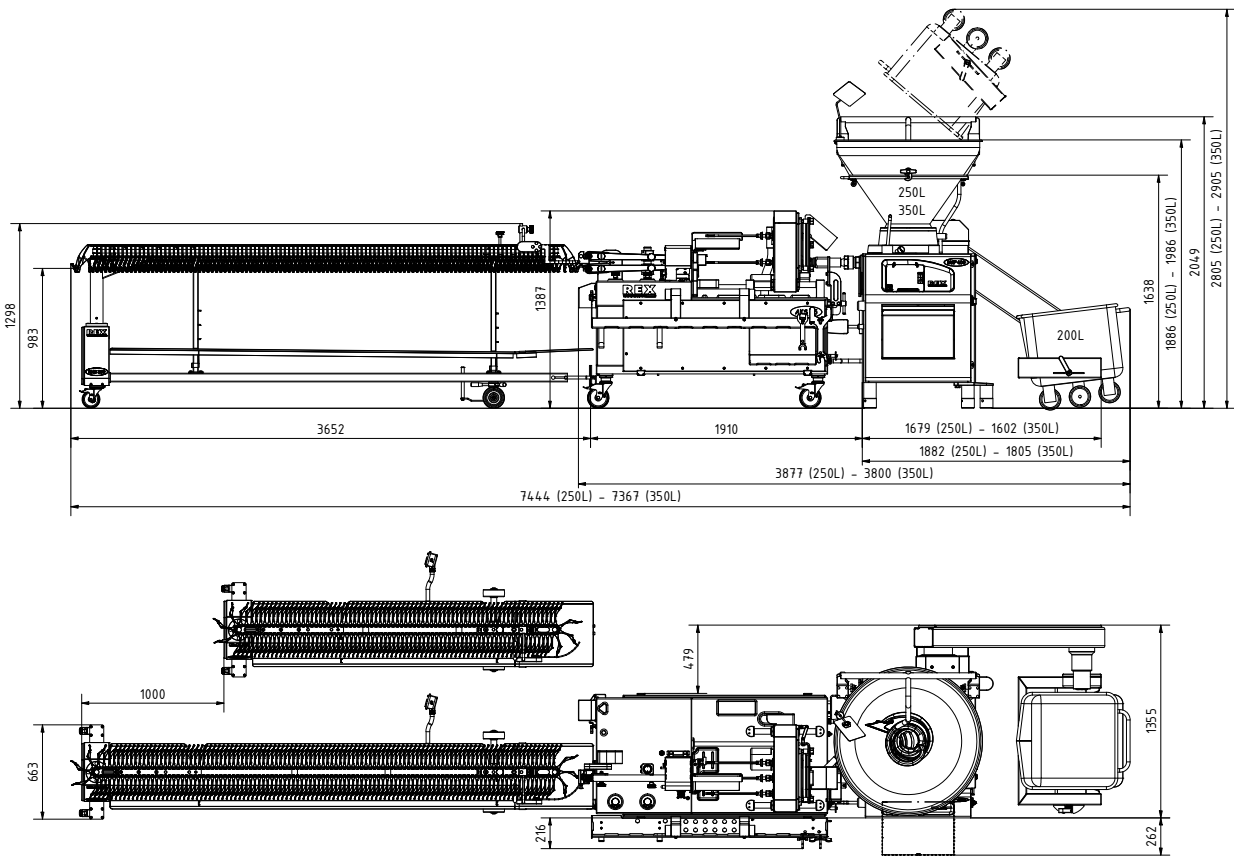

Scale drawing RVF 700 + AKS 65M + RHS 330H / RHS 235H

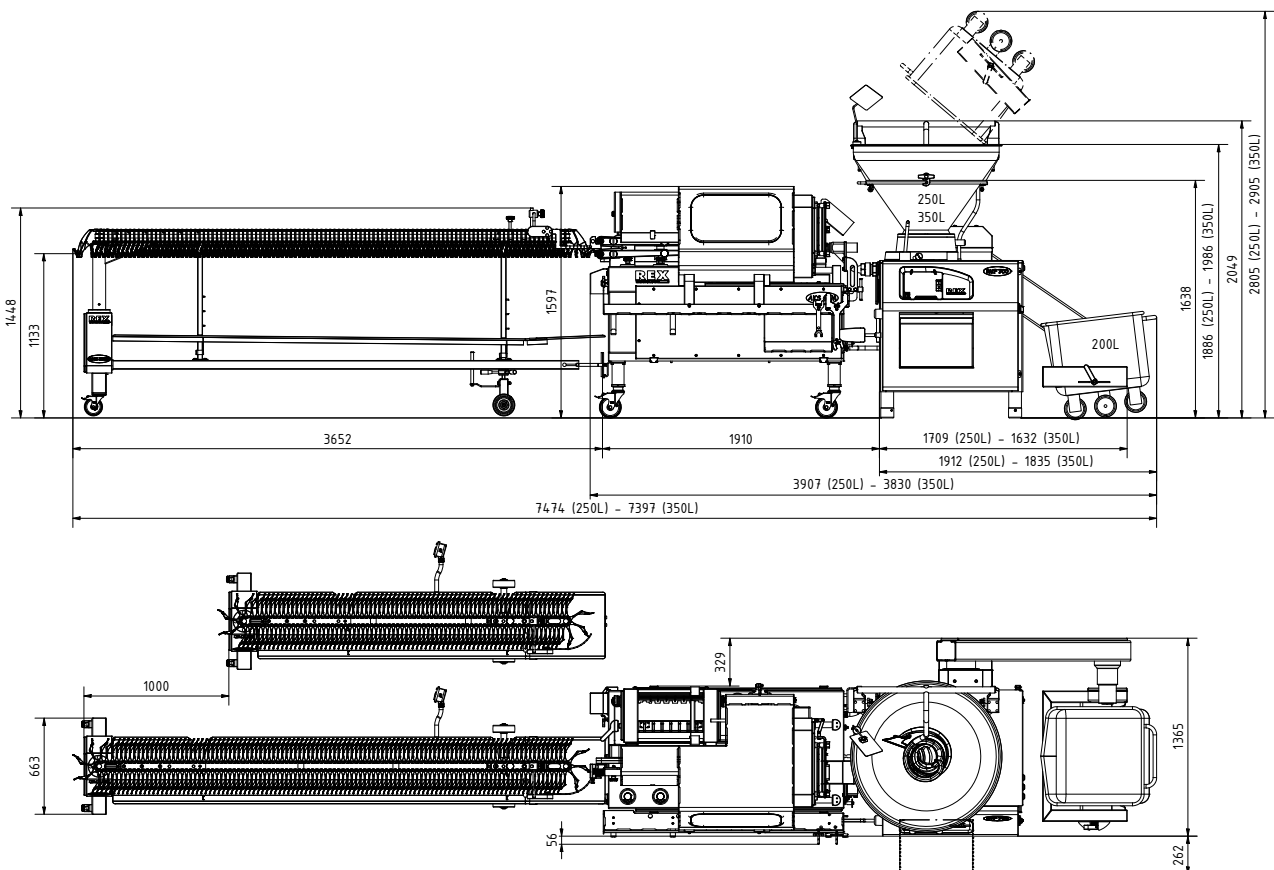



REX-Technologie GmbH & Co. KG
Irlachstrasse 31 • A-5303 Thalgau
Phone +43(0)6235-6116-0 • Fax +43(0)6235-6529
E-Mail: sales@rex-technologie.com
www.rex-technologie.com



The images in this brochure can only serve as a guide because printing colours do not reflect the brilliance of the paint.
Changes of technical details as well as misprints and printing errors reserved.