



Long life technology.

MULTISPLITTER SAW

The new MULTISPLITTER SAW with splitting conveyor has a special design with multiple saws that are working in parallel providing longitudinal cuts.

The machine stands out for its versatility, inasmuch as the possibility to be customized depending on the necessities of the customer.

The conveyor track with variable speed and easy regulation of the belt helps to get a better adaptation to the product, which can be sliced in multiple cuts.

It is a continuous cycle machine, compact and easy to use. The operator has to enter the product into the belts and it comes out on the other side split.

Furthermore, it has a security design that save your company from OSHA fines from employees being hurt on meat band saws.



THECNICAL FEATURES

Engine with assisted brake	11 kW
Belt engine power	2 x 0,25 kW
Dimensions	1068x1588x2030mm

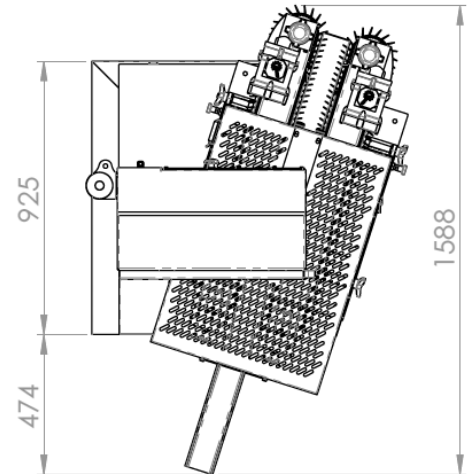
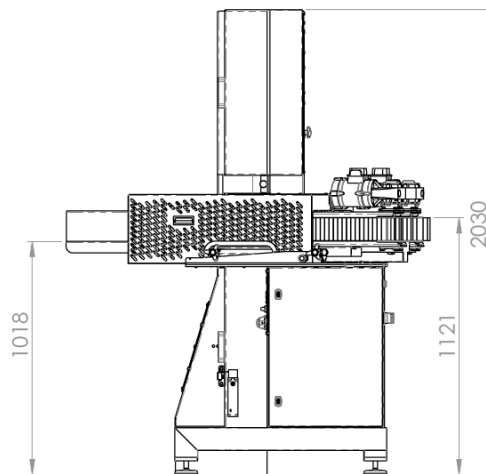
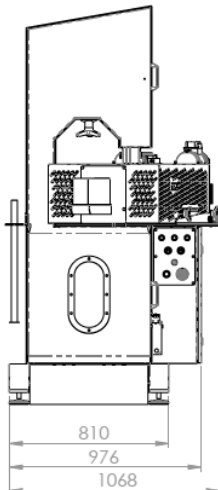

Long life technology.

Mainali.com info@mainali.com

+34 972 460 476

WhatsApp / T. Móvil +34 669491715

Les serres, 22, 17244, Cassà de la Selva. (Girona). SPAIN