

# TE

## ADVANCED DIGITAL LINEAR METAL DETECTOR

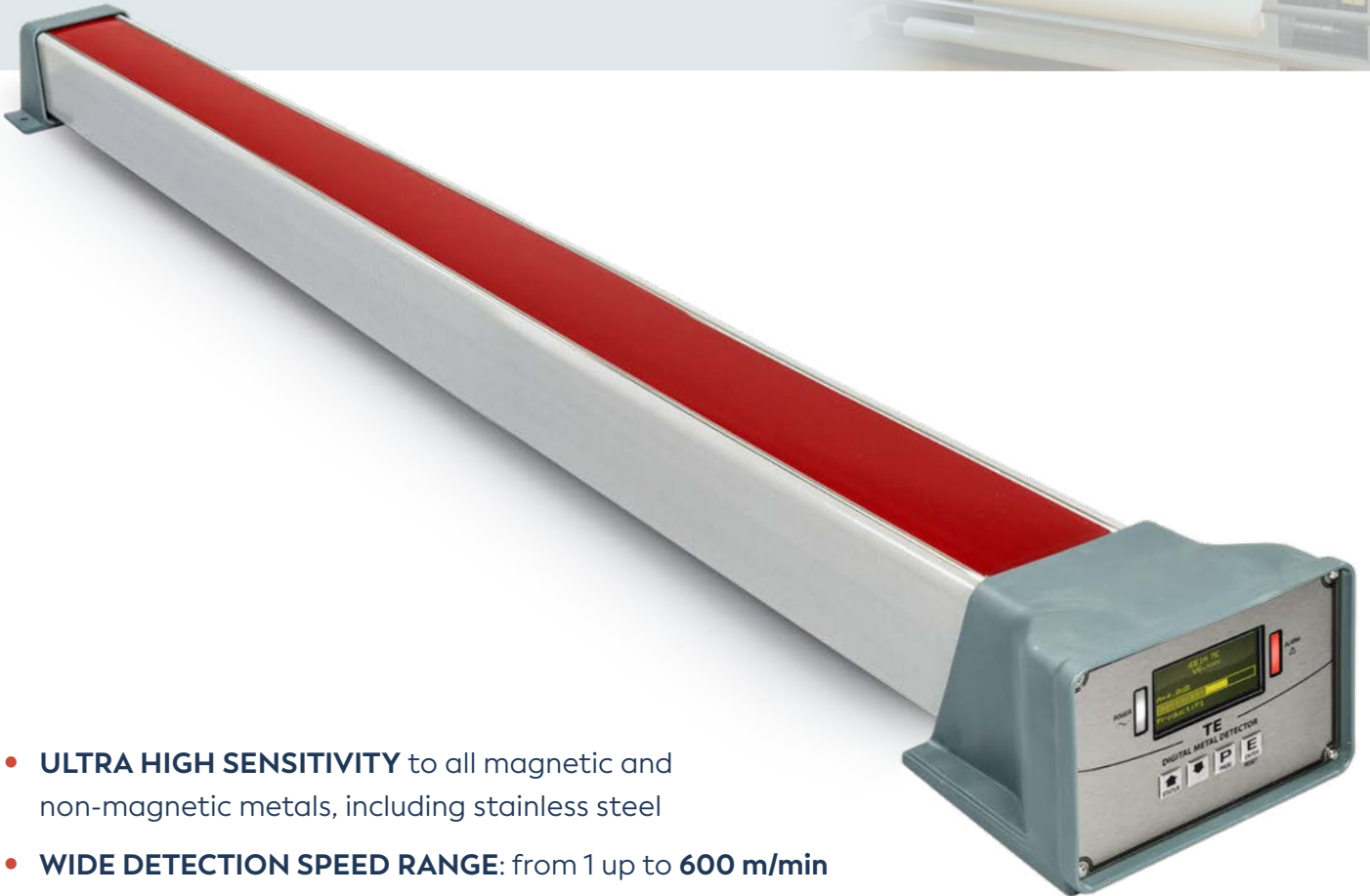

- **ULTRA HIGH SENSITIVITY** to all magnetic and non-magnetic metals, including stainless steel
- **WIDE DETECTION SPEED RANGE:** from 1 up to **600 m/min**
- **DURABLE DETECTION SURFACE**
- **COMPACT** and **ROBUST CONSTRUCTION**
- Very high electrical and mechanical **IMMUNITY**
- Remote display and keyboard unit available (**RCU**)
- **CONTINUOUS AUTOTEST** and **DIAGNOSTIC**
- **EASY INSTALLATION** and **SETTING**
- **WIDE OPERATING TEMPERATURE RANGE**
- **STAND-ALONE** and **SEPARATE CONTROL UNIT VERSION (RC)** available

### BENEFITS

- ✓ QUALITY CONTROL
- ✓ PROTECTION OF MACHINERY
- ✓ MINIMUM PRODUCT REJECT

### APPLICATIONS

- ✓ PAPER AND BOARD
- ✓ TEXTILE AND GARMENT
- ✓ PLASTICS AND RUBBER
- ✓ RECYCLING
- ✓ NON WOVEN
- ✓ FIBER GLASS FILM



w w w . c e i a . n e t



**QUALITY CONTROL AT ITS FINEST**

The **TE Digital Metal Detectors** are the ideal means of protection and quality control for production lines against accidental damage caused by fragments of metal which can enter the manufacturing process along with the material under inspection.

### CEIA TEXTILE QUALITY CONTROL

CEIA began the design and production of solid state metal detectors for textile machinery protection right from its foundation, in the 1960s, offering since then top performances in terms of sensitivity and immunity to environmental interference. **To date, tens of thousands of CEIA TE devices, installed all over the world, protect textile machineries from possible damage** caused by the presence of metal contaminants, with uninterrupted reliability and constant performance.

Metal fragments, in the form of small objects, such as pins, needles or staples, accidentally present in the fabric in the various processing phases, can cause scratches, dents, or gouges in the machinery, for instance on the calenders roller surfaces, leading to compromised fabric quality and permanent damage. In these cases, the loss of production and the repair operations involve significant costs.

**By utilizing CEIA metal detectors, textile manufacturers can safeguard their machinery from metal contamination.** CEIA TE detectors enable early detection of the metal contaminants and automatic shutdown of the machine, halting the roller rotation to prevent further contact with the metal object. **This not only protects the machinery but also ensures fabric quality and uninterrupted operation of the textile production process.**

### PROGRAMMING FEATURES

- **INTERNAL DATA LOGGING** with data and timestamp for Quality Control
- Password protected with **SEPARATE USER** and **ENGINEER LEVEL**
- **BT COMMUNICATION** for setting and maintenance through external PC
- **AUTOLEARN FUNCTION** for automatic setting of the maximum sensitivity in dry and wet conditions
- **BUILT-IN FUNCTION FOR AUTOMATIC MEASUREMENT** of the external interferences

### MODERN, RUGGED AND USER FRIENDLY PROGRAMMING

- Industrial rate design
- Rapid data entry
- Easy to read, high-contrast graphic OLED display
- Rugged, antivandalic stainless steel keyboard



Display of the status of the metal detector



Display screen in case of detection

### TE OVERALL DIMENSIONS (mm)

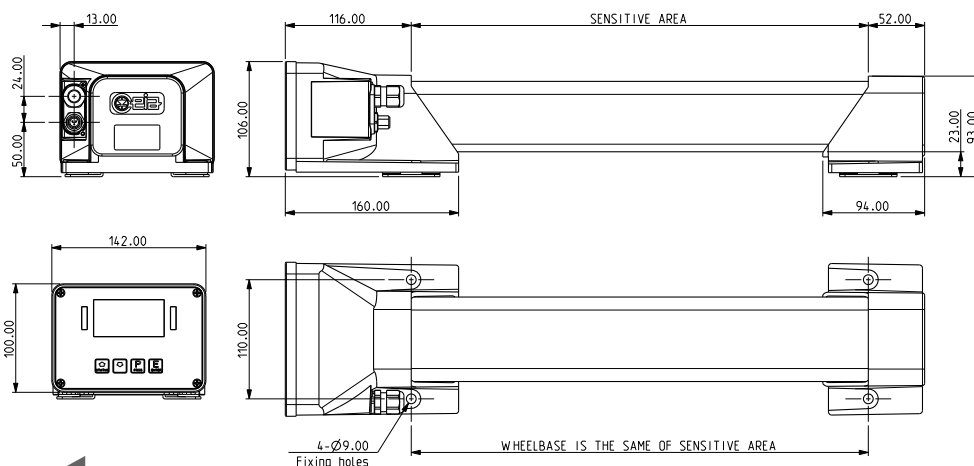

Other widths available on request

MODEL	SENSITIVE AREA
TE 1300	1300 mm
TE 1500	1500 mm
TE 1700	1700 mm
TE 1900	1900 mm
TE 2100	2100 mm
TE 2300	2300 mm
TE 2500	2500 mm
TE 2700	2700 mm
TE 2900	2900 mm
TE 3100	3100 mm
TE 3300	3300 mm
TE 3500	3500 mm
TE 3700	3700 mm
TE 3900	3900 mm
TE 4100	4100 mm
TE 4500	4500 mm
TE 5300	5300 mm

Digital signal analysis allows the user to optimize detection with respect to the product's speed and the metals to be intercepted, thus obtaining the best possible immunity to any external interference.

**The TE Metal Detector is tested and compliant with the applicable Electrical Safety and Electromagnetic Compatibility standards.**

EXAMPLE OF APPLICATION DIAGRAM (LINE STOP IN CASE OF METAL ALARM)

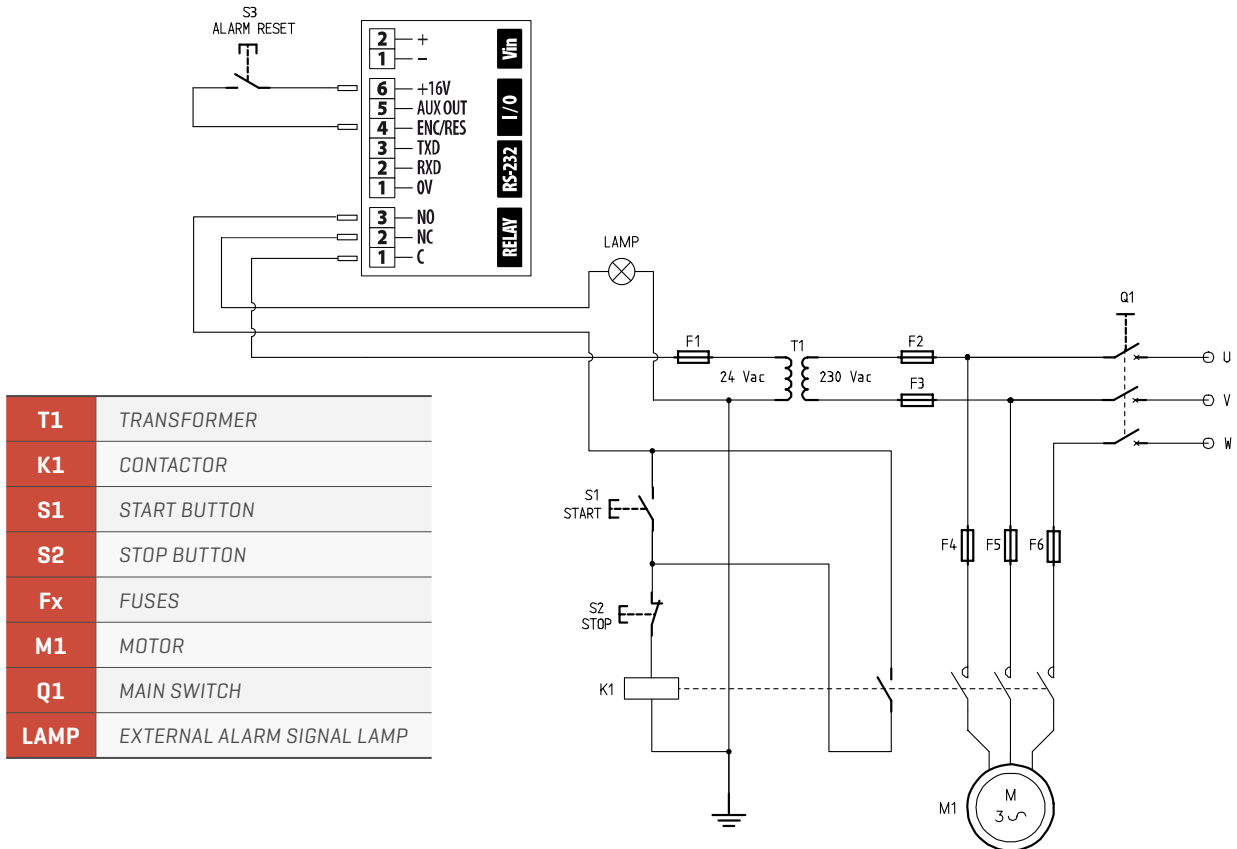

TYPICAL TE APPLICATION CONFIGURATION

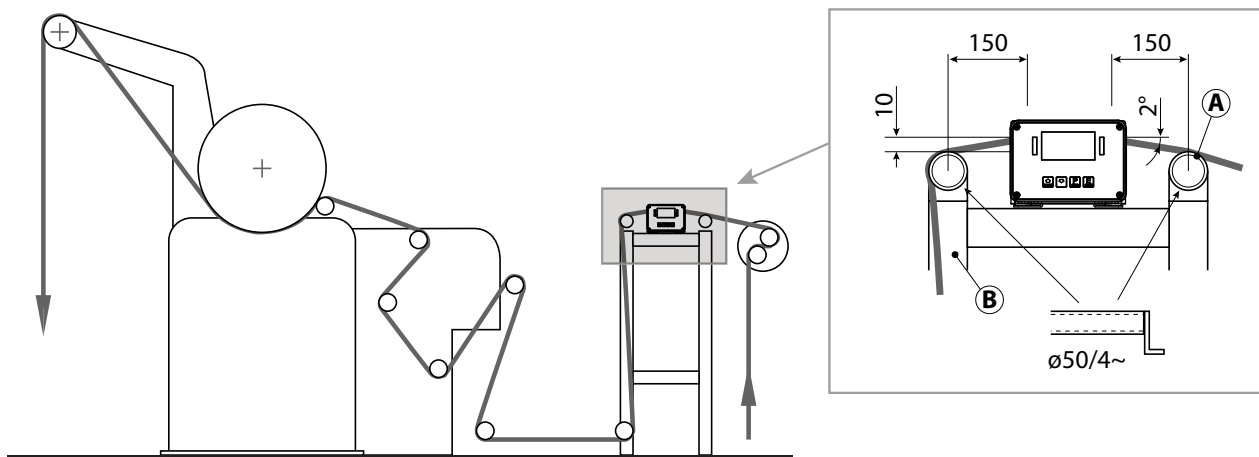

Mounting on a support frame at the cloth entry-point of a calender: **A**, steel tube; **B**, steel structure profile

# TE - ADVANCED DIGITAL LINEAR METAL DETECTOR

**EASY INSTALLATION  
AND SETTING**

**DURABLE DETECTION  
SURFACE**

**COMPACT AND ROBUST  
CONSTRUCTION**



TE-XXXX-RC model (Bar with Remoted Control Panel)

## SPECIFICATIONS

<b>KEY FEATURES</b>	<b>Sensitivity area length:</b> from 1300 mm to 5300 mm
	<b>Detection speed:</b> from 1 up to 600 m/min
	<b>Detection capability:</b> ultra high Sensitivity to magnetic and non-magnetic metals, including stainless steel
	<b>Immunity:</b> high Immunity to mechanical & electrical interferences
	<b>Applicable to:</b> all type of fabrics and materials
<b>SIGNALLING</b>	<b>Audible:</b> Internal buzzer
	<b>Visual:</b> Graphic display with bar-graph indication Bright indicators on Control Panel: RED (alarm or fault) GREEN (power supply)
<b>PROGRAMMING</b>	<b>Type:</b> Local: through built-in keyboard Remote: wireless BT or RS232
	<b>Data capabilities:</b> Internal memory: 1000 events, 20 products
	<b>Programming access:</b> 2 access levels: Operator and Supervisor
<b>INTERFACES</b>	RS232 and BT wireless
<b>INPUTS</b>	Connection for Alarm reset or Encoder input
<b>OUTPUTS</b>	1 programmable relay Alarm relay
<b>POWER SUPPLY (external AC/DC adapter)</b>	<b>Voltage:</b> 100-240 V~ 1ph - 50/60 Hz
	<b>Current:</b> 0.64A max
<b>SAFETY</b>	Galvanic isolation of line voltage
	Low operating voltage No danger for the operator
	Compliant with international standards of safety and radio interference
<b>ENVIRONMENTAL DATA</b>	<b>Temperature:</b> Operating -10 to +50 °C Storage -25 to +60 °C Higher product temperature on demand
	<b>Relative humidity:</b> 5 to 90 %, without condensation
<b>CERTIFICATION AND CONFORMITY</b>	• Low Voltage (LVD) Directive 2014/35/EU
	• EN 60204-1:2018 Safety of machinery - Electrical equipment of machines - Part 1: General requirements
	• Electromagnetic Compatibility (EMC) Directive 2014/30/EU
	• EN 61000-6-4:2007 +EN61000-6-4:2007/A1:2011 Electromagnetic compatibility (EMC) -- Part 6-4: Generic standards - Emission standard for industrial environments
	• EN 61000-6-2:2005 + EN 61000-6-2:2005/AC:2005 Electromagnetic compatibility (EMC) -- Part 6-2: Generic standards - Immunity for industrial environments

### TE-RC CONTROL PANEL



- IP65 high degree of protection

### REMOTE CONTROL UNIT (RCU)



- Separate control unit available (duplicate display and keyboard of control unit)

### QUALITY CONTROL SAMPLES

CEIA offers samples for quality assurance testing certified



phone +39 0575 4181 • qa-detectors@ceia-spa.com

www.ceia.net



CEIA reserves the right to make changes, at any moment and without notice, to the models (including programming), their accessories and options, to the prices and conditions of sale. DP001K0005v2000hUK - 117990 (2023)