



5

things you need to know before buying an aftermarket differential



EATON

Powering Business Worldwide

5

things you need to know before buying an aftermarket differential

INTRODUCTION 3

Overview: A quick breakdown of different types of differentials

TYPES OF DIFFERENTIALS 4

Overview: Use the table to help decide which differential you need

PICKING THE RIGHT DIFFERENTIAL 6

Overview: Use the table to help decide which differential you need

WHAT MAKES A QUALITY DIFFERENTIAL? 7

Overview: What makes a quality differential and how to tell

WARRANTY 7

Overview: What to expect from warranties and potential quality warning signs

PRICE 8

Overview: The old adage "you get what you pay for" holds true

SUMMARY 8

Overview: Revisiting the information so far

INDUSTRY SUPPLIERS 9

Overview: A breakdown of suppliers within the aftermarket industry

EATON PERFORMANCE AFTERMARKET DIFFERENTIAL PORTFOLIO 10

Overview: Information on differentials provided by Eaton



EATON

Powering Business Worldwide

Introduction

So you want to upgrade the differential in your vehicle, but don't know what is the right one to buy? This guide will explain the advantages and disadvantages of the various types of differentials so that you can make a more informed decision. Whether you are transforming your daily driver to a street/strip machine or want to improve your off-roader, there are a certain types of differentials that are right for your application.



5 things you need to know before buying an aftermarket differential

1. Types of Differentials

Let's start with a quick overview of the various types of differentials.

Open

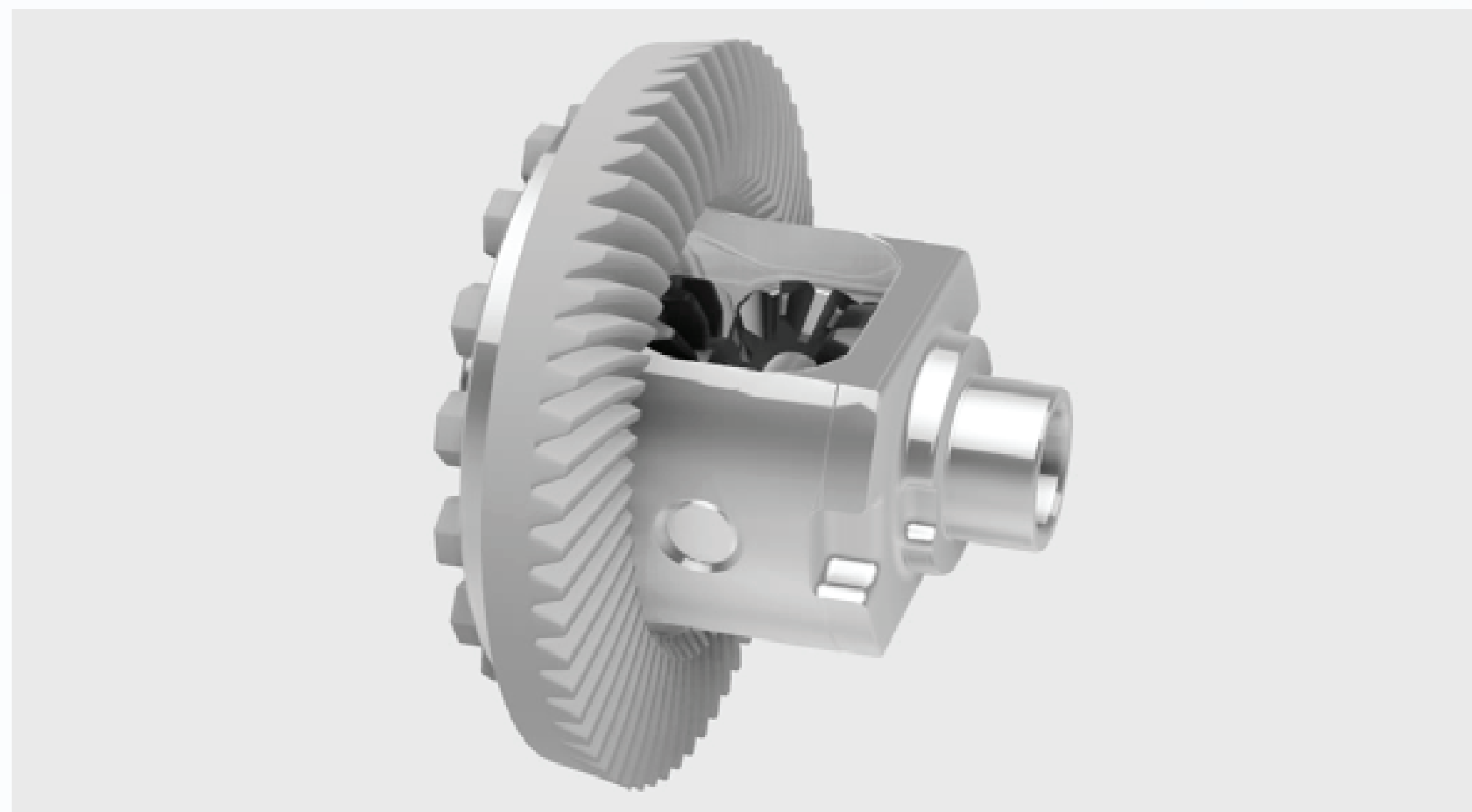

Open Differentials are the most common differential found on passenger vehicles and allow the wheels to rotate at different speeds while the vehicle is turning a corner. They don't work well on uneven or slippery surfaces because the engine torque is transmitted to the wheel with the least resistance (a.k.a. "traction"). If the tire is off the ground or on ice, it spins freely and the vehicle is unable to move. On asphalt, you get the infamous "one-wheel peel" under heavy acceleration.

Limited Slip



Arguably the most common type of differential due to their wide range of applications, mechanical limited slip (LSD) or positraction (Posi™) differentials shift a portion of the torque

to the wheel the most traction and limits the slip on the wheel with the least traction. Because of this, these differentials are often referred to as "torque sensing." Like an open differential, the wheels can rotate at different speeds. However, unlike an open differential, the torque is not always balanced between the wheels. This allows the wheel with traction to receive more torque in order to continue to move the vehicle. In other words, the differential is said to "bias" more torque to the higher traction tire. The disadvantage is that the amount torque that can be transmitted to the wheel with the most traction is also limited. This may not be enough torque to move the vehicle. And it's important to note that limited slip and positraction differentials will not provide 100% lock up of the differential in extreme situations such as when a wheel completely loses traction.



An Eaton Posi Limited Slip Differential

LSDs come in three types: clutch, cone or gear-driven.

- Clutch –springs apply pressure to the side gears and onto clutch packs consisting of alternating layers of friction discs and steel discs. The clutch plate design is rebuildable by replacing the clutch plates.
- Cone – uses friction-lined cones instead of a clutch pack. Cone clutch design are susceptible to noise / chatter and are not typically rebuildable.
- Gear-driven – uses a set of gears and a principle called gear separation force to transfer torque to the higher traction wheel. Exhibit the highest torque carrying capacity for a given axle application but are not typically rebuildable.

Examples:

- Eaton Posi™
- Detroit Truetrac®
- Auburn Gear High Performance, Pro and Race Series
- Ford Performance Traction-Lok and Torsen
- G2 Axle & Gear Limited Slip
- Powertrax No-Slip, Grip LS and Grip Pro
- Quaife ATB
- Strange Engineering S-Trac
- Summit Racing Trac-Loc
- Wavetrac
- Yukon Gear & Axle Dura Grip® and Trac-Loc

5 things you need to know before buying an aftermarket differential

Locking

During turns, a locking differential operates like an open differential- the wheels can rotate at different speeds. However, when traction is needed, the axles can be mechanically locked together forcing the wheels to rotate at the same speed. This is especially helpful in off-roading situations when one wheel is off the ground or on an otherwise very low traction surface. When locked, the wheel in the air doesn't receive any torque because there is no traction and the wheel on the ground receives all the torque allowing the vehicle to move.

Some lockers are known for being noisy and harsh on the street, with sometimes unpredictable impacts on handling, especially in corners and wet/ice/snow conditions, but the ability to have fully locked axles is worth those trade-offs for some drivers.

Drop-in or "lunchbox lockers" replace the stock spider gears or limited slip clutches with a locker section and are an easy to install, lower cost option. However, they are not as strong as a traditional locker because they rely on the OEM carrier and reliability could become an issue if power adders, larger wheels and tires, and other modifications are made to the vehicle.

Lockers use various methods to lock the axles together. Actuation varies from automatic to driver-selectable.

Just like the name says, automatic locking differentials require no driver action and automatically lock the axles together when torque is applied. Some automatic locking differentials, such as the Eaton MLocker®, commonly found on General Motors pick-up trucks and SUVs are normally open, automatically lock upon loss of traction (while traveling under 20 miles per hour) and automatically unlock when conditions allow. Others, like the Detroit Locker®, are normally locked, automatically unlock during turns and automatically re-lock when conditions allow.



Driver-selectable locking differentials require the driver to activate a switch, usually located on the dash, which activates an electromagnetic assembly or vacuum diaphragm to actuate the engagement collar or clutch which locks the axles. Some Lockers use a lever and cable to lock the axles together. Air lockers have added installation complexity and cost due to the required air compressor and air line plumbing.

Examples:

- Eaton ELocker® and ELocker4®
- ARB Air Locker
- Auburn Gear ECTED Max
- Dana Spicer Electric Locker
- G2 Axle & Gear Core Locker
- OX Locker
- TJM Pro Locker
- Yukon Gear & Axle Zip® Locker



Examples:

- Detroit Locker®
- Auburn Gear Max Lock
- Powertrax Lock-Right and Grip LOK
- Yukon Gear & Axle Grizzly® and Spartan®



An Eaton Detroit Locker Locking Differential



An Eaton ELocker Locking Differential

5 things you need to know before buying an aftermarket differential

Spool

Technically, this not a differential, but we'll include it in this discussion. A spool and mini-spool permanently lock the axles together so that the wheels turn at the same speed. They are great for a dedicated drag racer or serious off-road racer, but are not recommended for use on the street due to tire wear and chirp and associated excessive driveline loads.



Examples:

- Dana Spicer
- Strange Engineering
- G2 Gear & Axle
- Yukon Gear & Axle

2. Picking the Right Differential

This is not a 'one size fits all' situation. Knowing how and where you plan to drive your vehicle will help you select the best differential. Use this table to find your applicaton.

	Drag Racing	Circle Track	Restoration	Street and Muscle	Work Truck/ Towing	Light Trail/ Sand Sports	Rock Crawling	Extreme Off-Road
Limited Slip	●	●	●	●	●	●		
Locking	●	●	●	●	●	●	●	●
Spool	●	●						●



3. What Makes a Quality Differential?

Now that you've identified your use and what differential might be best suited for that application, how do you compare the various differential manufacturers? Let's set price aside because we'll address that later. Instead, let's focus on the attributes for a good quality differential. There are 3 things to consider:

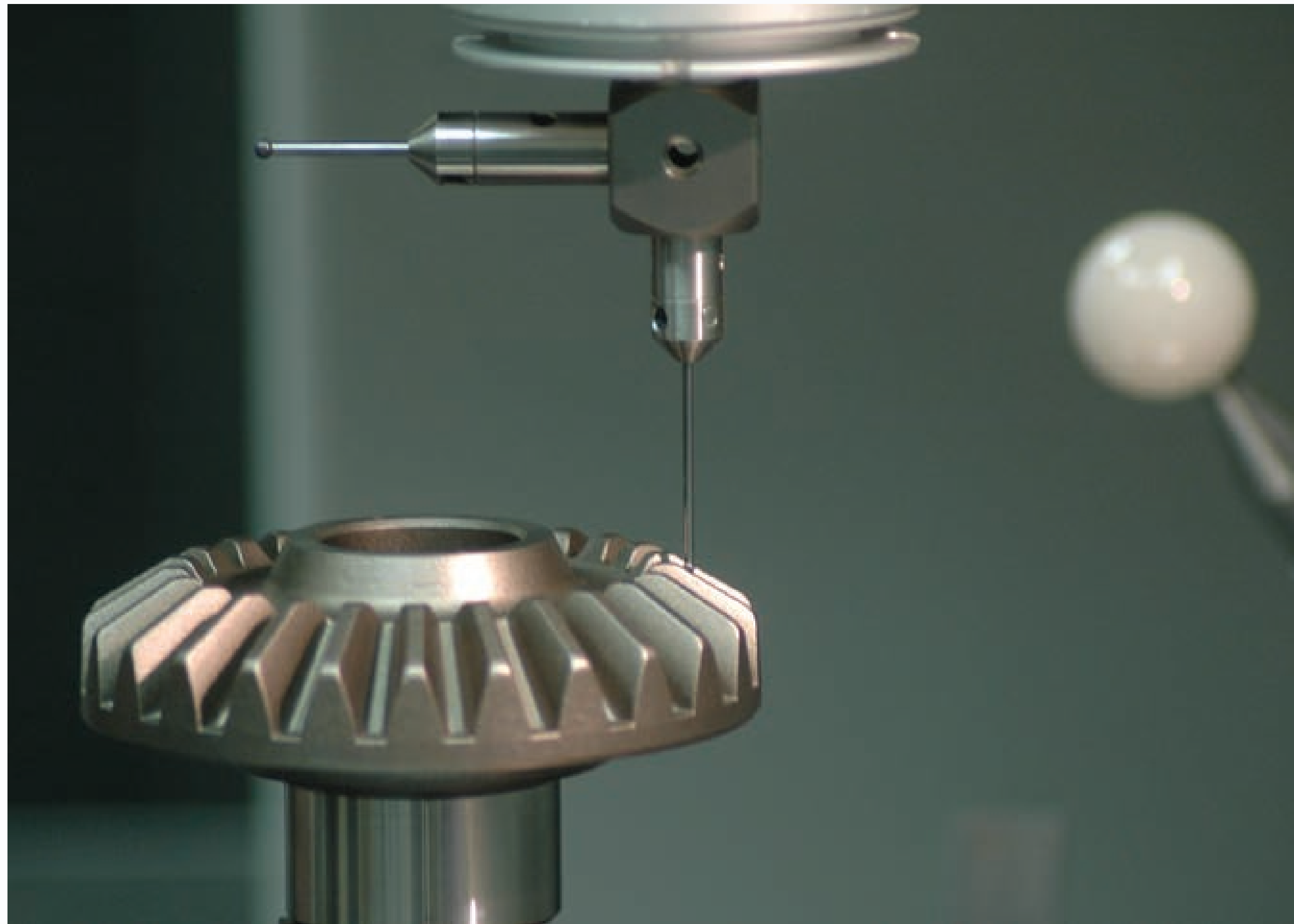

- 1. Materials** – look for quality components. Differential cases are usually made of nodular cast iron or forged from steel alloy. Spider gears and side gears should be net-forged, hardened and made from high strength steel.
- 2. Manufacturing** – what kind of facilities does the manufacturer have? Is it ISO certified (an industry quality certification)? Does the company use a one-off or repeatable assembly process? Repeatable assembly process typically ensures better quality. How many differentials do they make per year? Volume production is typically associated with higher quality.

3. Reliability and durability – the best manufacturers use Finite Element Analysis (FEA) to computer simulate extreme driving situations even before a prototype is created. Those prototypes then undergo hours of testing, both in the laboratory as well as in-vehicle, including destructive testing to find the weak points. Finally, production-intent units are field tested to ensure they meet the engineering requirements. Some companies, such as Eaton, are OEM suppliers so their aftermarket differentials are designed to meet OEM standards. And only Eaton has a 650 acre OEM-level Proving Ground with a full complement of test facilities including on-road areas such a 1.6 mile track, high and low traction skid pads and off-road areas including a twist ditch, log walk, rock crawl and various grades including 45% and 60% hills!



4. Warranty

Let's talk warranty. A warranty covers defects in materials or workmanship for a period of time when the component is installed and used according to the application guidelines. It is not intended to cover a failure caused by incorrect installation or abuse.

Warranties on aftermarket differentials range from one year to a limited lifetime. Some companies even cover collateral damage to repair affected components in the event that the warranted part fails and damages other components. Removal and re-installation of the component, loss of vehicle use, and other towing is not usually covered.

However, just because a product has a long warranty, doesn't mean it's the best product. Long warranties might mask inferior product quality and the costs associated with covering warranty claims is usually added into the price of every differential sold.



5. Price

Prices vary for the many kinds of differentials, but the old adage “you get what you pay for” still holds true today. Go with a lower priced product and you might have to replace it if it fails. Considering that a shop can charge upward of \$1,000 to install a differential, this is not a cost that you want to pay more than once.

What is your threshold for break downs? You work hard to pay for the parts for your car or truck, so paying a little extra for high quality upfront might just save you money in the long run.



Summary

Hopefully you now have a better understanding of what you should look for when considering an aftermarket differential for your vehicle. Picking the right type of differential for your application is vital. Many factors go into making a quality product. A long warranty doesn't necessarily mean the product is the best. And price always comes down to “pay me now or pay me later.”

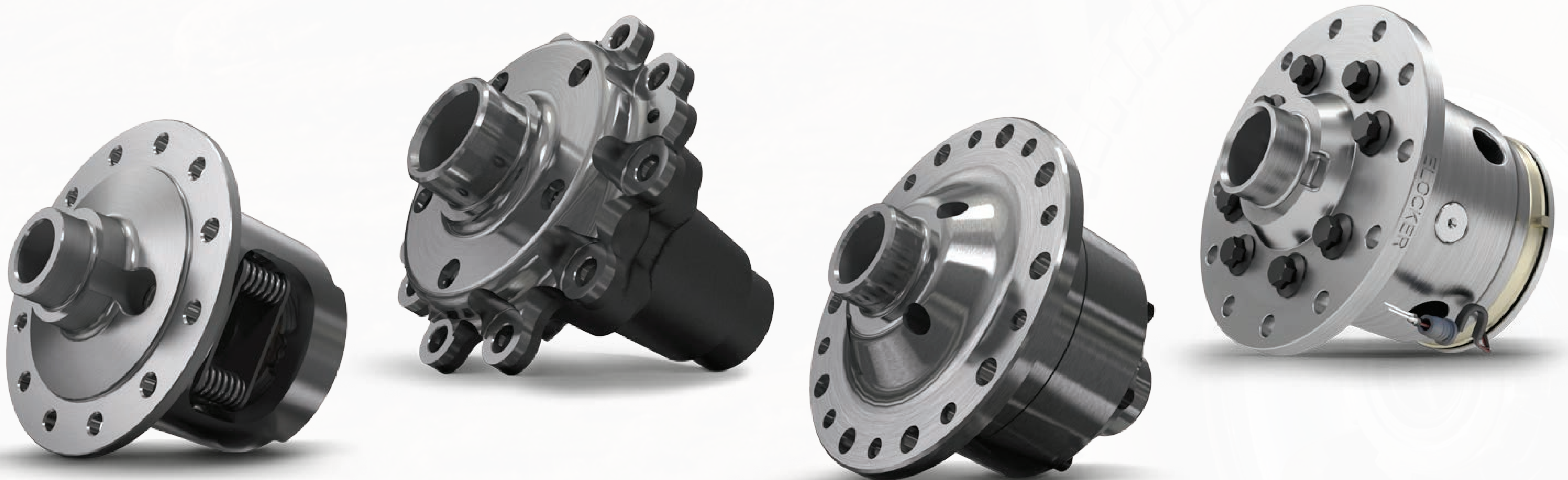

5 things you need to know before buying an aftermarket differential

Suppliers in the Industry



ARB

Australia's largest manufacturer and distributor of 4x4 accessories.

Auburn Gear

Founded in 1982 in Auburn, IN and offering differentials for Chrysler, Ford, GM, and Toyota vehicles.

Dana

Founded in 1904 and based in Maumee, Ohio, Dana supplies OEM and aftermarket products.

Eaton

Manufacturer of the Eaton and Detroit Locker product lines, Eaton is the largest manufacturer of differentials in the world.

G2 Axle & Gear

An aftermarket drivetrain supplier located in Compton, CA.

OX

Manufactured by FMG (Florida Manufacturing Group) located in Odessa, FL.

PowerTrax

Located in Chicago, IL. Manufacturer of aftermarket differentials.

Quaife

Headquartered in the United Kingdom, RT Quaife Engineering Ltd. supplies products for cars, motorcycles and specialty-use vehicles.

Wavetrac

A line of limited slip differentials manufactured by AUTOTECH Driveline.

Yukon

Yukon Gear & Axle located in Everett, WA and manufactures aftermarket drivetrain parts.

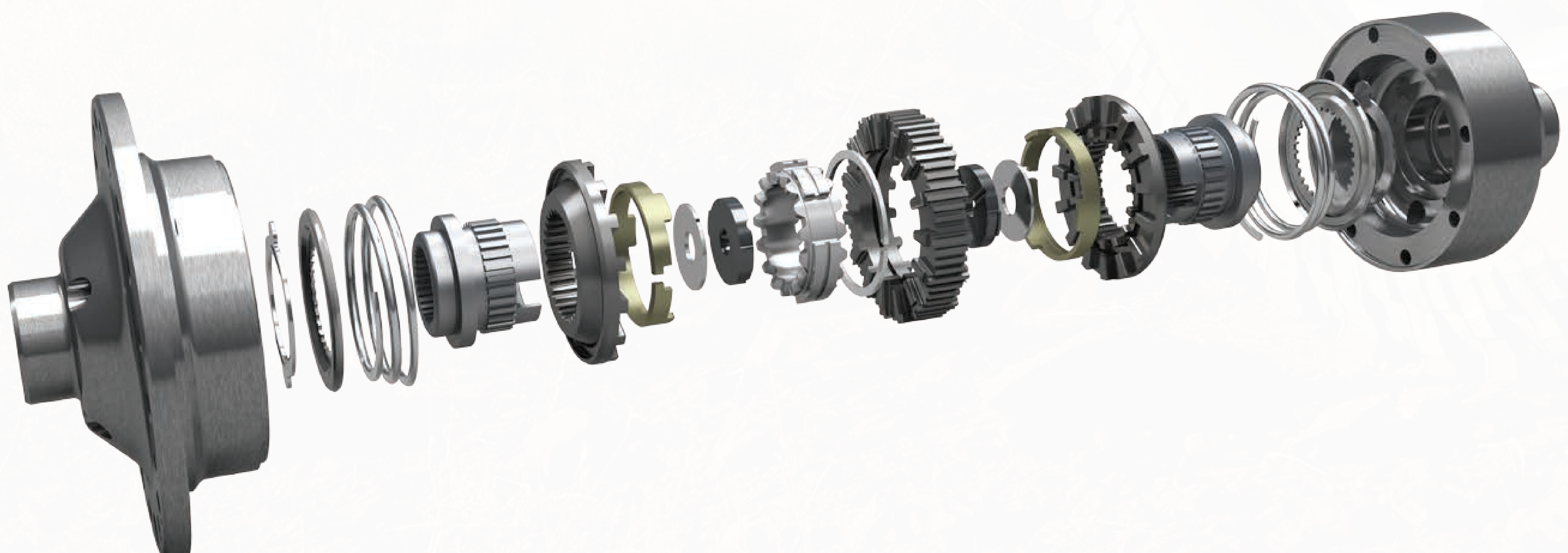

Eaton Performance Aftermarket Differentials

Posi™

Muscle cars, street rods, classic restorations and mild off-road vehicles should look to the Eaton Posi limited slip differential for their traction answers. Pyrolytic carbon clutches are extremely durable & temperature tolerant and are derived from airliner & Formula One racing brake applications.

The Eaton lockers are probably one of the most well known locker in the marketplace and have become the brand that people commonly use to describe all lockers. The reason behind this is the quality and reputation for being the best locker, so much so that you'll find that many competitors have tried to unsuccessfully copy the product.



The Eaton Posi Limited Slip Differential

- Pyrolytic carbon clutches
- Tunable via various spring packs (a.k.a. pre-loads)
- Rebuildable design
- Net-forged gears for added strength
- Smooth, automatic operation
- "Top Treat" (friction modifier) must be used with each fill or if noise is heard
- Works equally in forward and reverse
- Optimized torque bias ratios deliver maximum vehicle acceleration and handling

Posi®

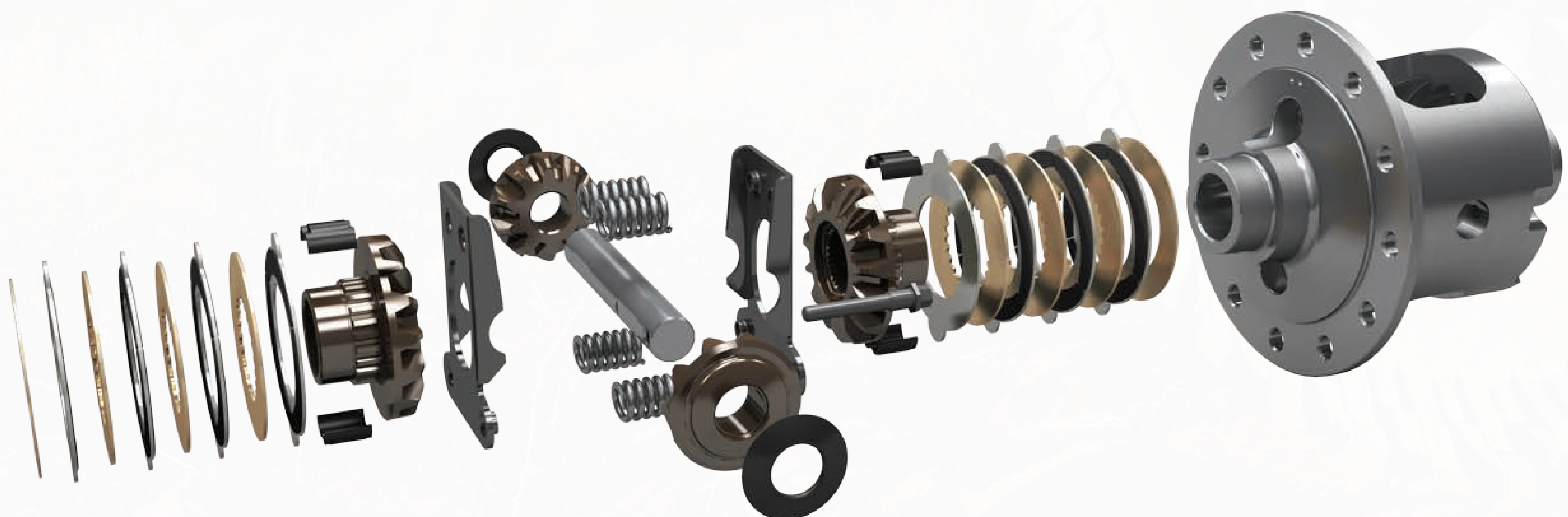

5 things you need to know before buying an aftermarket differential

Detroit Truetrac®

The Detroit Truetrac® can transfer or bias up to 3.5 times more torque to the high traction wheel, if needed. The combination of no maintenance requirements, extreme durability and smooth performance make the Detroit Truetrac limited slip differential an ideal application for on-road street performance, autocross, off-roading, and demanding towing applications.

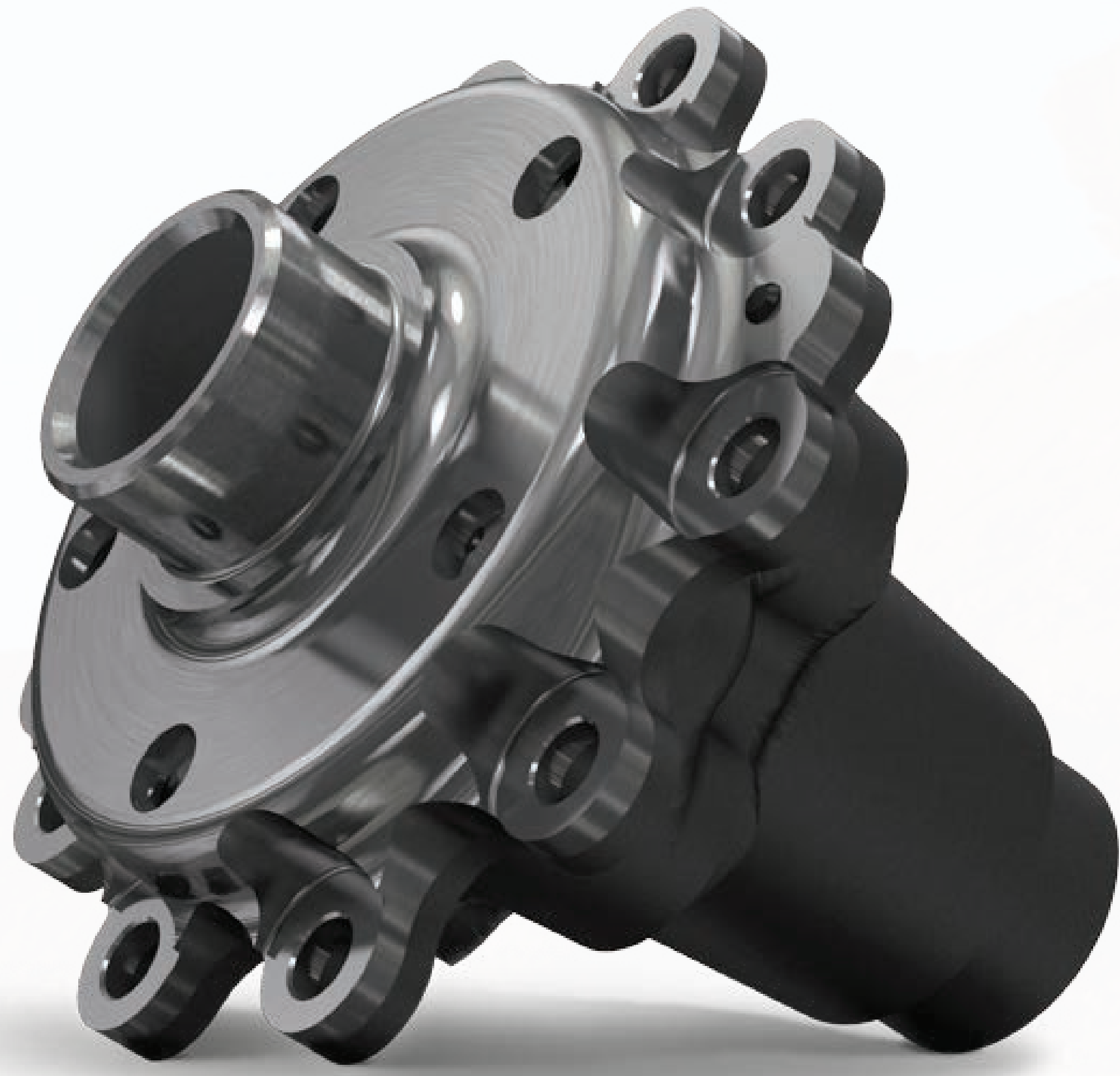

The Eaton Detroit Truetrac Limited Slip Differential



- Automatic engagement
- Unmatched strength & durability
- Maintenance-free – no special lubrication or friction modifiers required
- Works in forward and reverse
- Front or rear axle application
- Optimized torque bias ratios deliver maximum vehicle acceleration and handling



5 things you need to know before buying an aftermarket differential

Detroit Locker®

Virtually bullet-proof, this speed sensitive automatic locking & unlocking differential powers both drive wheels. Automatically permits wheel speed differentiation as needed. No other performance differential has the reputation for delivering traction in mud, snow, rocks and on the track. The choice of professional racers and off-road enthusiasts around the world!



- 100% automatic locking
- Unmatched strength & durability
- Maintenance-free – no special lubrication or friction modifiers required
- Works in forward and reverse
- Front or rear axle application

The Eaton Detroit Locker Locking Differential

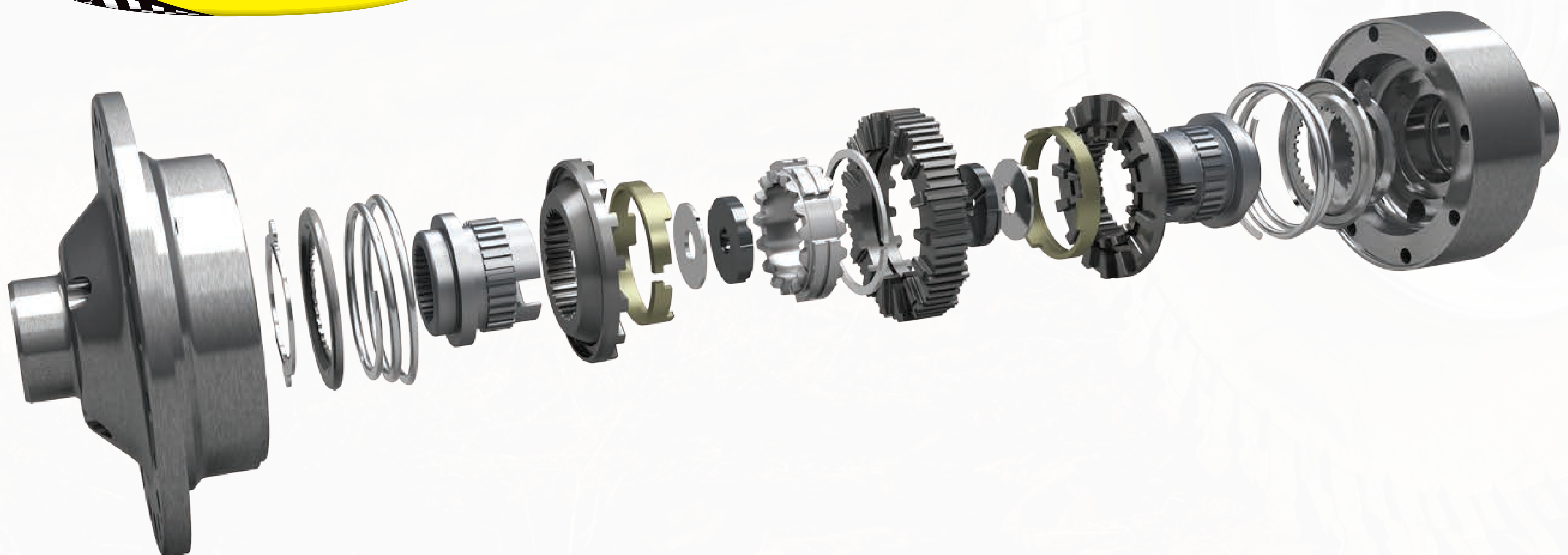

5 things you need to know before buying an aftermarket differential

ELocker®

The ELocker® is built with precision-forged gears that are designed to mesh perfectly, providing improved strength and durability. Its ease of installation, reliability and push-button activation make the ELocker an absolute must for front or rear axle off-road applications.



The Eaton ELocker Locking Differential



ELocker®

- Driver selectable operation
- Net-forged gears for added strength
- Full axle lock upon driver command (normally open = fully "streetable")
- Maintenance-free – no special lubrication or friction modifiers required
- Most reliable on-demand differential
- Works in forward and reverse



Find an Eaton Distributor at EatonPerformance.com



For more information, application guide and videos please visit EatonPerformance.com



© 2017 Eaton
All Rights Reserved
Printed in USA
EPDL200 0617
June 2017



Eaton Performance Products
26101 Northwestern Highway
Southfield, MI 48076 USA
800-328-3850
www.EatonPerformance.com

Note: Although every attempt has been made to ensure the accuracy of information contained within, Eaton makes no representation about the completeness, correctness or accuracy and assumes no responsibility for any errors or omissions.

Eaton, Detroit Locker, ELocker and Detroit Truetrac are registered trademarks of Eaton. All other trademarks, logos and copyrights are those of their respective owners.