

**Your Partner in
Exhaust and Emission**



AFTERMARKET

**EURO 5 & 6
BUS SYSTEMS
FROM TURBO
TO TAILPIPE**



Stepping up to the latest standard

Air pollution is a major concern to European communities and individuals, and exhaust gases must be controlled to reduce the negative impact.

The official constraints on vehicle emissions follow a natural path. The present Euro 6 norm reduces the particulate and NOx emissions to unprecedented levels, promising to make heavy transport more friendly to the environment than ever before.

Euro 6 and beyond

This important endeavour requires advanced exhaust and emission solutions. Dinex products meet or exceed the Euro 6 norm and include the widest range of type approved aftertreatment system sparepart components, so truck manufacturers and the aftermarket naturally rely on us to help them equip for the new standard. In fact, we even deliver technologically advanced silencers for trucks and buses.

The greener, the better

Every day we work hard to reach even lower levels of particulate and NOx emissions, and we are every bit as ambitious with our aftermarket products as we are with our original equipment parts.

We are constantly working on new technologies, new products and more effective solutions that may be applied in current and future exhaust systems. We work hard to ensure emission compliance with OE equipment, but also to find ways to improve on areas like noise reduction, back-pressure performance and fuel consumption.

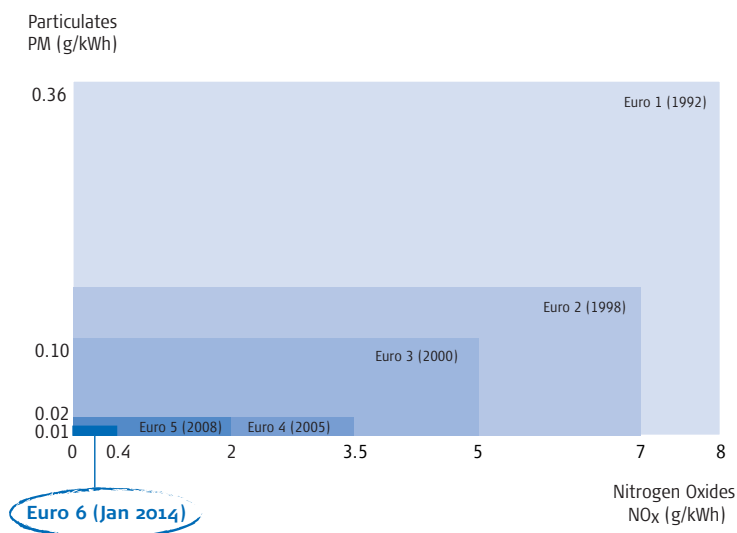

Cleaner air out of the exhaust pipe than the air you breathe!*

*In comparison to air polluted areas.



THE
GREENER
THE
BETTER

Table of content

2	Stepping up to the latest standard
6	Why partner with Dinex?
7	Why Dinex for your customers?
8	Type approved aftertreatment system components
9	The exhaust system evolution
10	Your Partner in Exhaust and Emission
13	In the Footsteps of Circular Economy
14	Common Failures
15	DENNIS Systems
18	IVECO Systems
28	MAN Systems
36	MERCEDES Systems
45	SCANIA Systems
51	VDL Systems
54	VOLVO Systems
63	Time for DPF Service?
64	Direct Replacement and Built-inParts
65	Dinex E-commerce Platform
66	Full Mechatronic Range
67	Aftermarket Division



We provide a complete

Dinex has extended the range of exhaust parts for the most popular Euro 5 & Euro 6 buses. The catalogue represents the by far most comprehensive and complete - turbo to tailpipe - emission system program available for buses, covering all parts needed to replace or service exchange any Euro 5 & 6 emission system.

The online bus catalogue sets new easy-to-use standards. The visual systems layout and schematics, combined with the quick-search function, technical information and a direct Webshop "add-to-basket" integration, provides a powerful and user-friendly working tool.

Check out the Euro 5 & 6 online bus catalogue with all the latest updates right here:



Are you still flipping through printed catalogues? Try the online experience now... It's easier than you think!

With more than 15,000 products available we offer the world's widest product range for on-road transport (LCV, trucks and buses), off-road and construction equipment.

- Diesel Oxidation Catalysts
- Selective Catalytic Reduction
- Diesel Particle Filters
- Front pipes
- Tailpipes
- Three Way Catalyst
- Pipe insulation
- Clamps
- Flex pipes and bellows
- Sensors
- Fittings
- Injectors
- Pumps

Integrated OE quality

Reliable performance is our main priority. We handle all production of ceramics, coating and metal forming in our own factories, and our entire programme is 95% in-house manufactured. This is our way to ensure optimum quality that equals and in many cases even surpasses original equipment.

Certified and approved

Probably needless to say, but Dinex is certified according to a number of international standards, including:

ISO 9001, ISO 14001, ISO 18001, ISO 50001, IATF 16949

Euro 5 and Euro 6 system product range

Insulation Techniques
Integrated to shield auxiliary components, and keep heat inside.

Flexible parts
Dinex uses its own 2S+, 3S flex pipes and bellow design to comply with leakage requirements.

Clamps
The portfolio includes Flat clamps, DIN clamps, V-clamps, Flex clamps and U-clamps.

Exhaust fittings
All fittings are made inhouse for complete systems supply.

Sensors
Sensors are designed to monitor exhaust system parameters and secure systems proper operation.

Pipes
Bending from 22 mm to 152,4 mm in alu or stainless steel.

Tailpipes
Direct replacement parts as well as universal tailpipes. Excellent quality parts made from aluminized, stainless steel or polished stainless steel.

Silencers
Dinex supply lock seamed, stamped or welded silencers in aluminized or stainless steel quality.

Emission technologies
DOC (Diesel Oxidation Catalyst), SCR (Selective Catalytic Reduction) catalysts and DPF's (Diesel Particle Filter) based on innovative in-house technologies.

Why Partner with Dinex?

Dinex Program Benefits

Providing tools and support



Products

Competitively priced Dinex DPFs (new and reconditioned), DOCs, SCR, bellows and pipe treatment systems. The Dinex portfolio also includes NOx-, Temperature- and Pressure Sensors, Fuel- and Injectors and Pumps for AdBlue®.

Quality: All Dinex parts are of OEM quality, and are a direct-fit installation out of the box. Each unit is quality tested prior to packaging.

Warranty: 3 years for aftertreatment systems (DPFs, DOCs, SCR), pipe treatment systems, 2 years for reconditioned DPFs and 1 year on accessories, electronic equipment (NOx and Temperature Sensors), bellows and flex.



Catalogues

Dinex offers the most user friendly, interactive and comprehensive catalogues for exhaust spare parts in the aftermarket industry. The catalogues are available in print and online versions with flip function and direct integration into the Dinex webshop.



E-Commerce

Webshop: Dinex.net is easy to use and will increase efficiency and ease the procurement of goods for the aftermarket. You will have the opportunity for ordering 24/7/365, check warehouse status & updated prices, quick cross reference search, CSV import, detailed descriptions and pictures. The fully responsive design allows for seamless access via pc and mobile devices.

www.dinex.net



Support

Customer Service: Talk to real people with dedicated aftermarket business support.

Sales Support and Training: Full technical product portfolio and sales training provided.

Cooperative Marketing: Co-branded flyers, ready to send email campaigns, social media promotions, and analytics offerings.

Why Dinex For Your Customers?

Warranty

3 years for aftertreatment systems (DPFs, DOCs, SCR) and pipes, 2 years for reconditioned DPFs and 1 year on accessories, electronic equipment (Mechatronic products), bellows and flex.



Exact Fit

No guessing or worrying if it'll work. Dinex DPFs, DOCs, SCR, and pipe treatment system kits are exact fit to OE, saving your time in the shop.



Reconditioned DPF Program

The Dinex reconditioned DPF is a relevant alternative to new DPFs, and in the long run a more economical and climate friendly alternative to regular cleaning. The DPFs are processed in a 3 step cleaning according to OE approved methods to secure performance, durability and extended service intervals. The kits include needed clamps and gaskets. See page 62 for more information.



Clamps and Gaskets Included

Clamps and gaskets are included in all DPF, DOC and SCR kits, saving you time and ensures customers receive the right parts for the right repairs.

Flex & Bellows Program

Dinex flex & bellows decouple engine torque and heat expansion for a better regeneration. Bellows 2S+ and 3S flex come in multiple dimensions and lengths to fit your needs.



Pipe Technology Systems

Dinex develops and manufactures complete pipe treatment systems having decades of experience and know-how, which enable us to offer cost-efficient solutions of the highest quality.



Mechatronic Program

The Mechatronic Program include a wide range of sensors, injectors, and pumps that are designed to secure proper system operation. Our range includes both new and professionally remanufactured parts, and some even comes with a used part refund arrangement.



Type approved aftertreatment system components

When you purchase Euro 6 Diesel Oxidation Catalysts, Diesel Particulate Filters and Selective Catalyst Reduction units from Dinex you can fully trust that our product range has been approved according to the UNECE regulation 49.

Today aftermarket manufactures also require a certificate proving that the replacement components not only comply with the emission limits, but also not affect the overall vehicle and exhaust system functionality as well. Dinex ensures our customers trustworthy aftertreatment system components from ordering to installation.

The approval includes predetermined testing at an independent European Automotive certification facility to ensure that Dinex aftertreatment system components meet the Euro 6 emission regulation throughout the product lifecycle.

By using Dinex spare parts for Euro 6 vehicles, customers can be certain that they will maintain the performance of the vehicle, without voiding the vehicles warranty or type approval. Non approved spareparts on the independent aftermarket can cause increased engine loads, higher fuel consumption and damaging downstream compenents, and may even make the driver and vehicle owner subject to legal action due to void of type approval.



Applus⁺
IDIADA

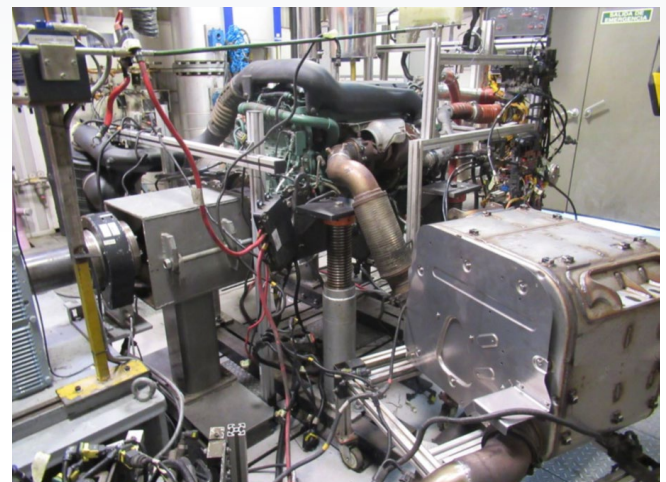

The exhaust system evolution

Over the past 3 decades the evolution of emission standards in most parts of the world, has driven a significant reduction of harmful substances in the exhaust of diesel vehicles. For instance, in comparison to the 1990s, modern heavy duty diesel engines emit 95-98% less Particulate Mass and NOx, reducing environmental footprint and improving air quality for the good of public health and natural ecosystems.

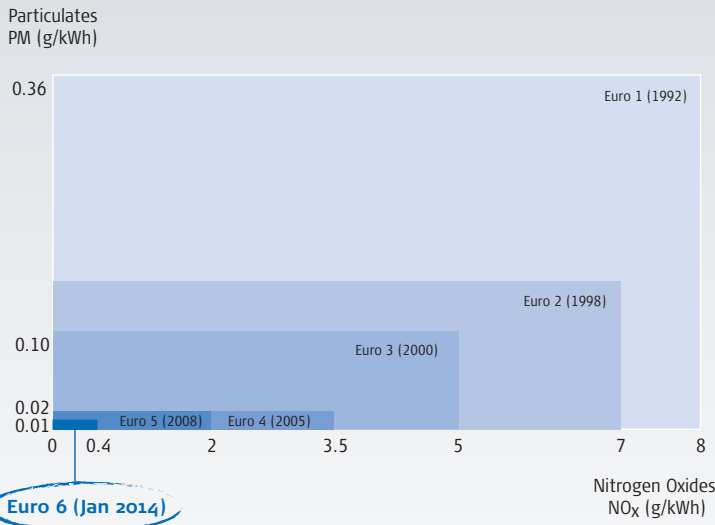

System w/acoustic silencer module (Euro 3)



System w/SCR (Euro 4-5)

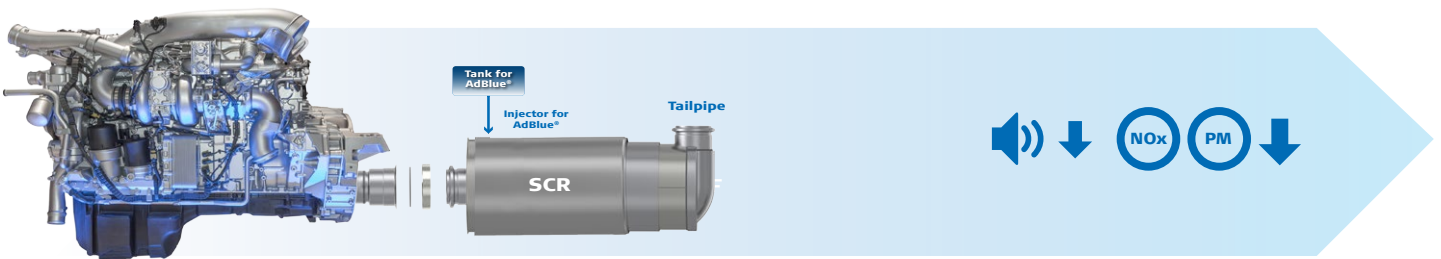

System w/DOC + DPF + SCR (Euro 6)

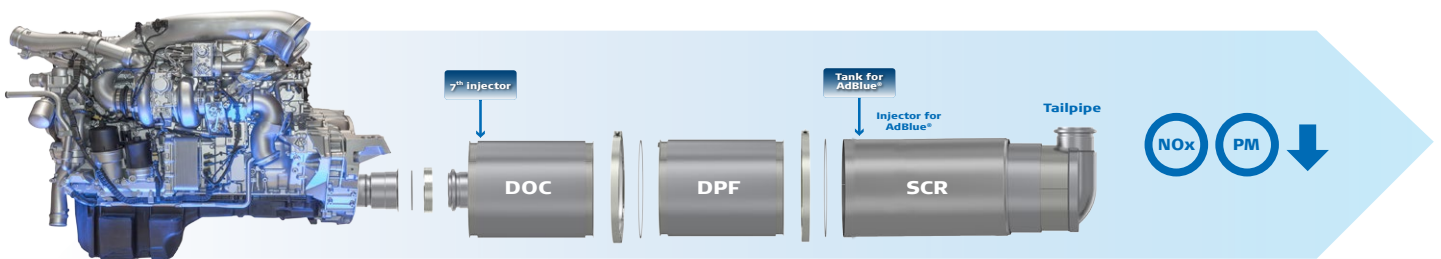

FULL SYSTEM COVERAGE

Dinex provides system and spare part solutions throughout the exhaust system lifespan!

Supplying trucks, buses and LCVs from turbo to tailpipe.



Temperature sensors

Features:

- Directly replaceable with OE sensors
- Tested at Dinex test center
- Tested and accredited by third party
- A good choice for proper ATS functionality

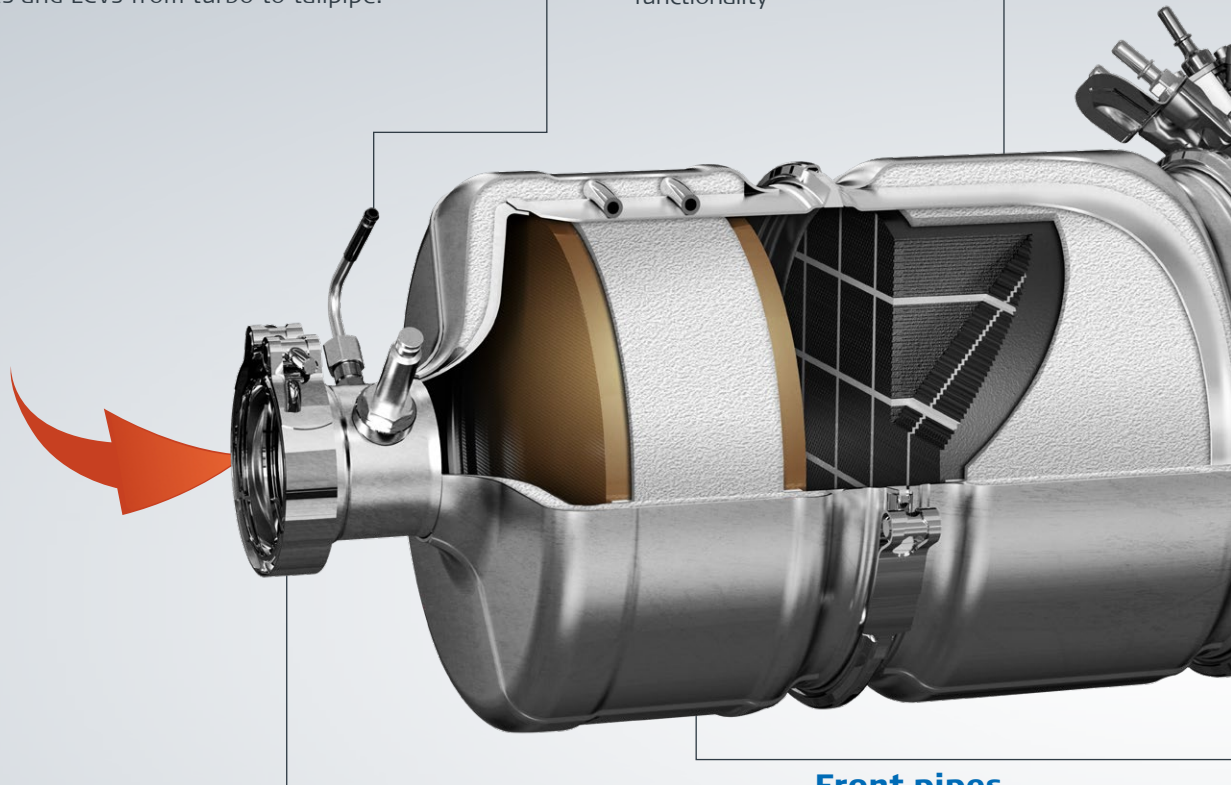

Front pipes

Material: Mild, aluminized or stainless steel

Dimensions: Ø22-152,4 mm

Features:

- Bent pipes from Ø22-152,4 mm.
- May be designed with bellows and D2S+ or D3S flex pipes from aluminized steel and stainless steel
- Directly replaceable with OE parts



**DEF
Injectors**



**DEF
Dosers**

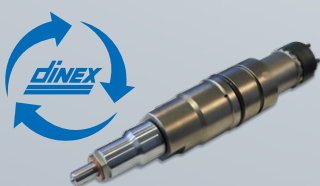

**Diesel Fuel
Injectors**



**Pressure
Sensors**





DPFs

- Material:** Cordierite or silicon carbide core
Dimensions: Ø116,5-375 mm
Features:
- In-house manufacture and coating
 - Manufactured according to OE technology
 - Match OE performance



NOx sensors

- Features:**
- Directly replaceable with OE sensors
 - Tested at Dinex test center
 - Tested and accredited by third party
 - A cost effective balance between emission control and Urea consumption



Mixers

- Material:** Stainless steel
Dimensions: Ø90-150 mm
Features:
- Mixing exhaust gas and Urea
 - Unique design for optimal exhaust gas and Urea flow

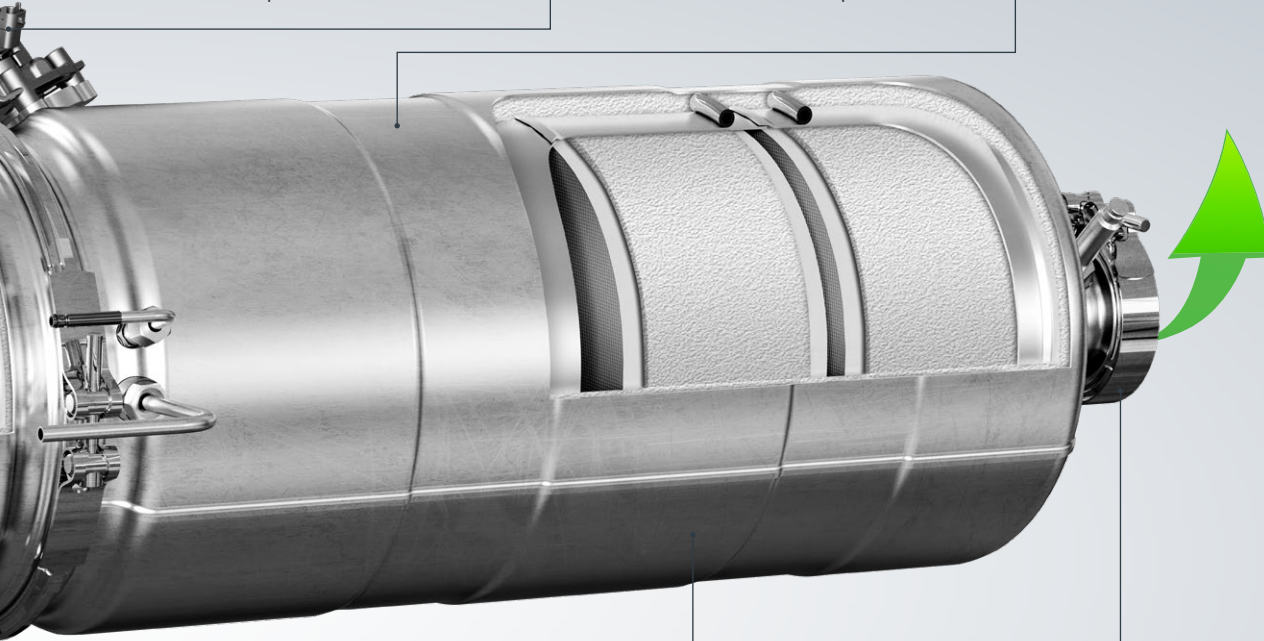

DOCs

- Material:** Metallic core
Dimensions: Ø152-350 mm
Features:
- High durability and effectiveness
 - Reduced backpressure and fuel consumption
 - In-house design and manufacture
 - Match OE performance

SCRs

- Material:** Ceramic core
Dimensions: Ø152-350 mm
Features:
- High durability and effectiveness.
 - Extended lifetime and higher efficiency
 - In-house developed technology and manufacture
 - Match OE performance

Tailpipes

- Material:** Mild, aluminized or stainless steel
Dimensions: Ø22-152,4 mm
Features:
- Bent pipes from Ø22-152,4 mm.
 - Directly replaceable with OE parts

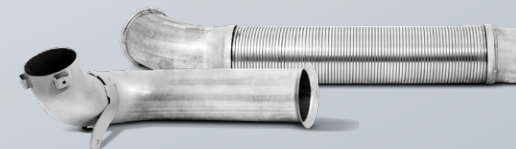

Widest global product range from turbo to tailpipe

Type approved DPF, DOC and SCR units

Global in-house manufacturing

Direct replacement of original exhaust parts

Local presence - we speak your language

Local technical & sales training sessions

Express logistics

Award-winning eCommerce (Webshop) solution

YOUR PARTNER IN EXHAUST AND EMISSION

going the extra mile



In the footsteps of Circular Economy

Did you know that the solutions which are the best for our planet, are often also those that are best for your operating costs?

The “use-and-throw-away”-mentality of Linear Economy is on a retreat, and Circular Economy is gaining ground. The Automotive Aftermarket is no exception, so if you’re not already familiar with concepts such as Remanufacturing and Reconditioning, it’s about time to get you introduced.

Remanufacturing

Definition: Restoring the functionality of a broken product, by replacing the faulty components with new ones.

Scope of application: Euro IV,V and VI silencers (a.k.a. OneBox)

A modern exhaust system is a complex system of catalysts and particulate filters. It is a durable unit but if failure occurs, replacement is a costly affair – financially, environmentally, and in terms of climate footprint.

Remanufacturing of faulty Euro IV, V and VI silencers is a clever alternative – if it’s done right! Bad spare parts or poor execution can result in damage to other components, loss of vehicle efficiency, or legal action in case of excessive emissions.

Dinex is ready to support professional providers of remanufacturing services with technical guidance, and a full range of high-quality, type-approved emission components. This is your guarantee for getting the most out of your remanufactured unit, save costs, and ensure continued compliance.

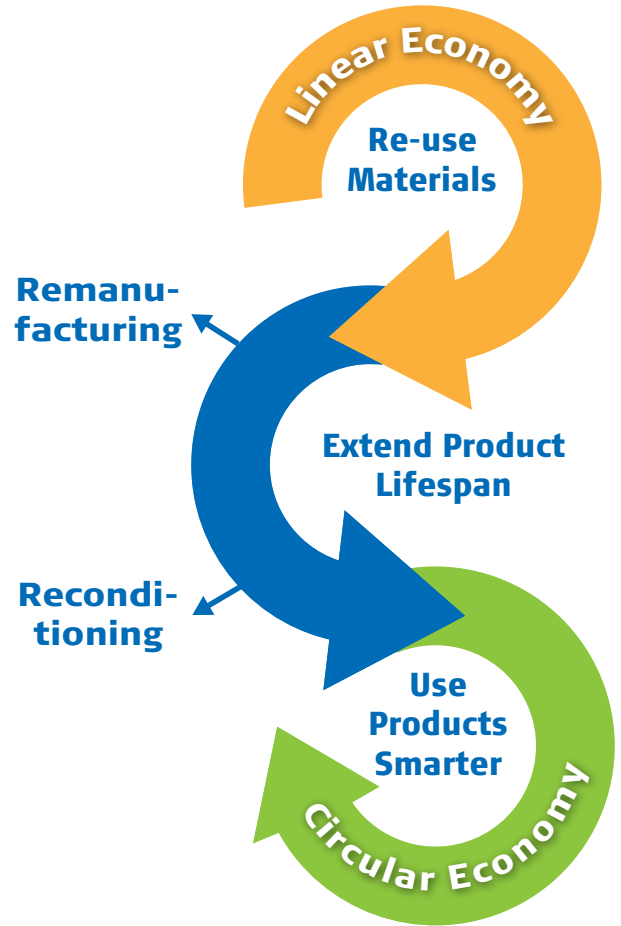

Reconditioning

Definition: Restoring a used product back to a near-new state.

Scope of application: Diesel Particulate Filters

A Diesel Particulate Filter (DPF) traps more than 99% of particulate matter in the exhaust, practically removing more than already typically present in the ambient air. But to prevent blockage of the filter it needs regular servicing, and that’s where you have to choose: Cleaning, or Reconditioning?

A simple 2-step cleaning by a professional workshop removes most ash and soot, but hardened ash will remain and act like a glaze that reduces regenerative ability, leading to increased back pressure, higher fuel consumption and more frequent cleaning (vehicle downtime). Reconditioning is a third step in which chemical dissolvents are applied to restore the functionality of the catalytic coating. You will experience the same benefits as installing a new filter, but at a much lower price.

Dinex Recon-RX is a full-range service enabling you to swap your existing filter with a quality-checked, type-approved reconditioned filter. You will be back in the road in no time - with 2 years warranty and a cash-back credit for the return of you old filter.

Common Failures

When do you see failures in the DOC?

Typically, it is not the DOC that fails, but a failure happens upstream. This causes the DOC to stop working and results in a cold regeneration.

Common DOC Failures

The HC injector clogged:

Fuel can mix with soot to clog the injector.

EGR coolant leaks & turbo fails:

Oil and coolant sent downstream will contaminate the PGM coating, leading to DOC inactivity. An inactive DOC will struggle to raise the temperature needed for a proper regeneration.

The air filter is full:

The DOC needs air when it ramps up to go through regeneration. If the air filter is full or clogged, the DOC will not receive enough air.



When do you see failures in the DPF?

Diesel Particulate Filters can fail due to failures upstream or due to high mileage, which fills it up with soot and ashes.

Common DPF Failures

Engine and Fuel system failures:

Fuel or oil can mix with soot to clog the DPF.

EGR coolant leaks & turbo fails:

Oil and coolant sent downstream will contaminate the PGM coating.

Air induction system failure:

Incorrect air amount in engine lead to excess soot.

Mileage and replacement intervals:

DPF like each filter has a limited service span. We recommend to replace the DPF with a new or reconditioned unit after every 200,000km on distribution vehicles and after every 400,000km on long distance vehicles.

Visible soot from tail pipe

The DPF may eventually crack allowing unfiltered exhaust to escape. Physical damage, excessive amount of trapped soot, or repetitive improper cleaning may lead to these cracks, and the filter should be replaced by a new or reconditioned unit as soon as possible.



When do you see failure s in the SCR?

Typically, for SCR failures root cause is in other system failures.

Common Failures causing problems with SCR

Failures in DEF system:

Incorrect operation of DEF system can cause damages on SCR.

Failures upstream:

SCR can be impacted not only by engine and it system failures, but also DOC and DPF failures.

Mechanical defects of substrate:

Substrate may slide out of canning or get some cracks.

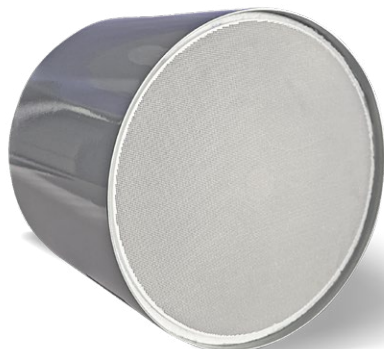

DENNIS



Content DENNIS

Very high quality ATS unit comprising replaceable silicon carbide DPF with PGM loading on the same level as OE to secure complete system functionality. The DOC, DPF, and SCR all function together as precision tuned instruments for the highest emission standards. Direct replacement for OE unit. Dinex also offers all exhaust pipes and other parts related to the exhaust system for Dennis buses.

Type/Model

ENVIRO 200	16
ENVIRO 400	17

EURO 6

4x2



Vehicle engine

Cummins ISB
4,5 ltr. / 4 cyl.
154KW / 210HP



Built-in substrates

DOC
9AA110



SCR with ASC
9AA121

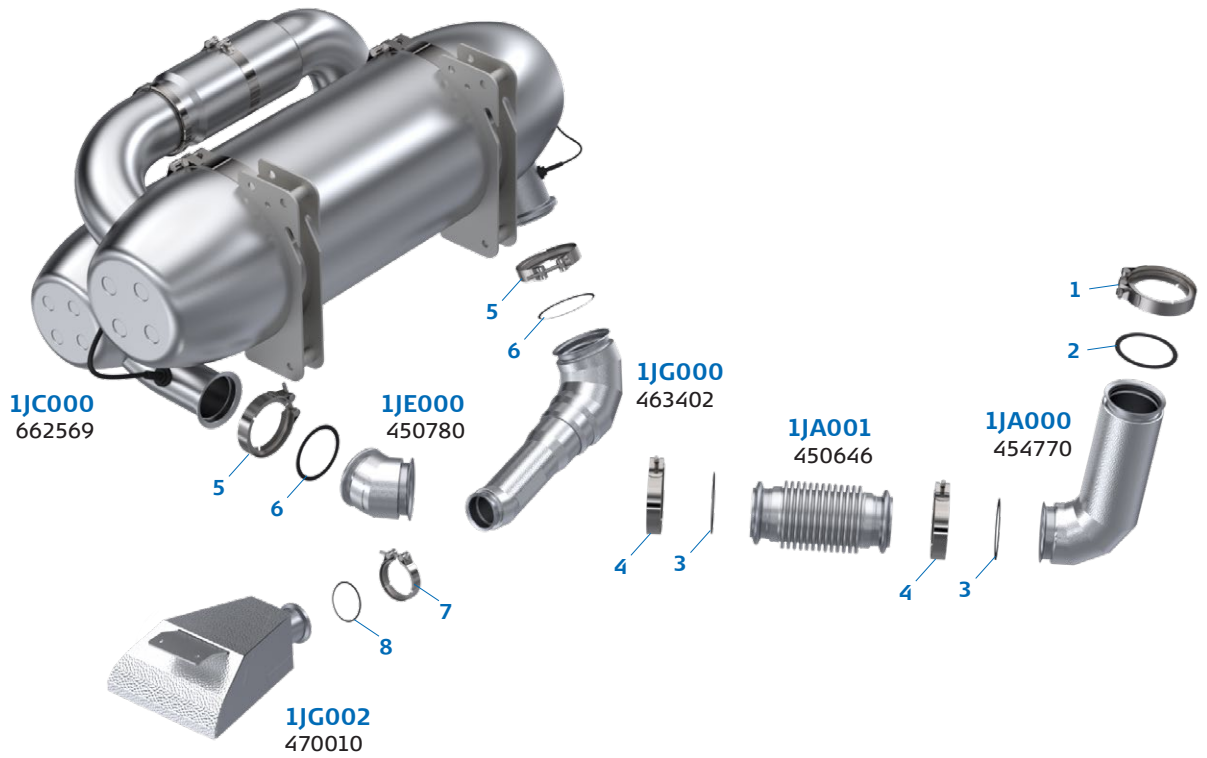
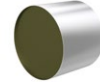

Mechatronics

Dinex no: 1JX002
OE no: 662529-14
Dinex no: 1JX003
OE no: 662529-15
Type: Temperature Sensor

Dinex no: 1JX000
OE no: 662529-12
Dinex no: 1JX001
OE no: 662529-13
Type: NOx Sensor

Dinex no: 1JX004
OE no: 662529-16
Type: Pressure Sensor

Dinex no: 1JT000
OE no: 662529-21
Type: Injector for AdBlue®

Accessories

No.	Dinex no	OE no	Type
1.	1JL000	663026	Clamp
2.	1JL001	663025	Gasket
3.	1JL002	661617	Gasket
4.	1JL003	661616	Clamp
5.	1JL004	661268	Clamp
6.	1JL005	457945	Gasket
7.	1JL006	664179	Clamp
8.	1JL007	664178	Gasket

Dinex diesel particulate filter kit

Dinex no: 1JI001 / New
Dinex no: 1JI001-RX / Reconditioned



OE no: 2137422, 1997433
Type: Diesel Particle Filter
Technology: HP-SiC

Dinex no: 2AL019
Type: Clamp

Dinex no: 2AL018
Type: Gasket

Kit number: 2AL017
OE no: 1997442

EURO 6

4x2



Vehicle engine

Cummins ISB
6,7 ltr. / 6 cyl.
187KW / 250HP



Built-in substrates

DOC
9AA045



SCR with ASC
9AA100

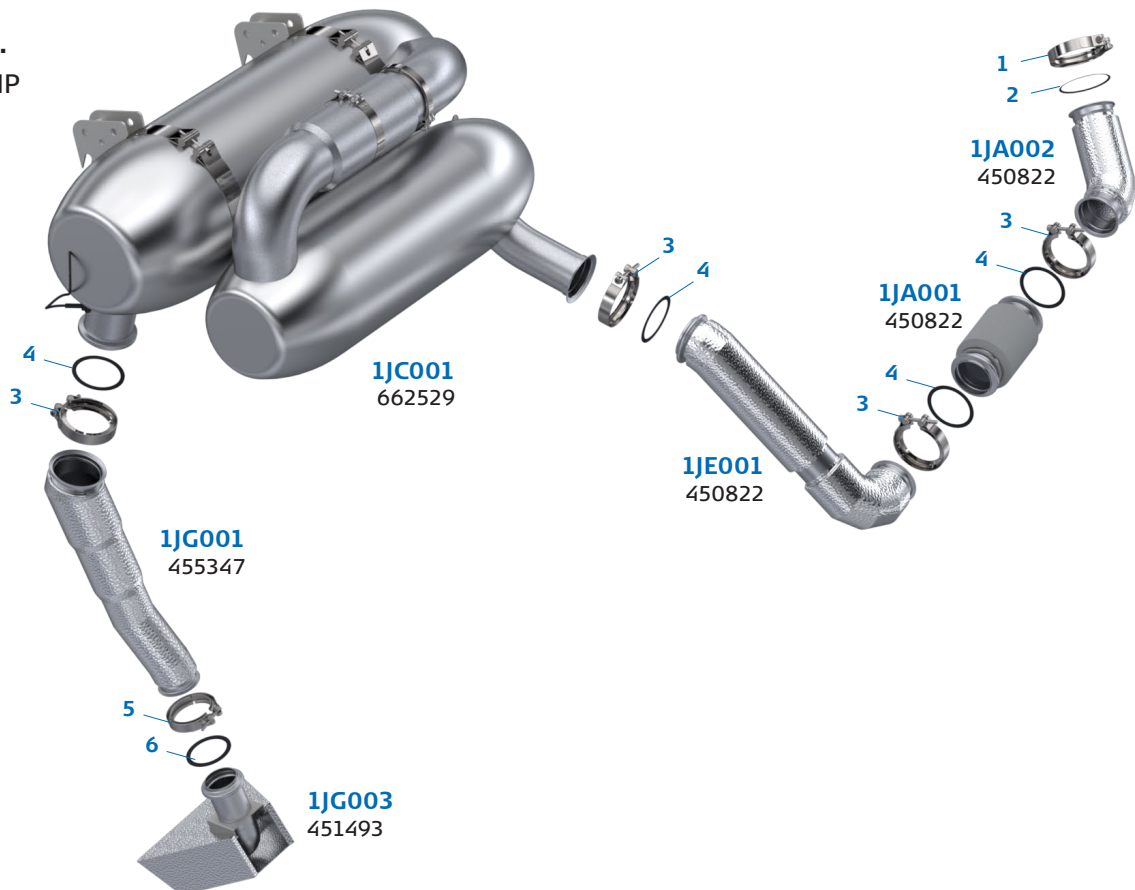
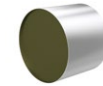

Mechatronics

Dinex no: 1JX002
OE no: 662529-14
Dinex no: 1JX003
OE no: 662529-15
Type: Temperature Sensor

Dinex no: 1JX000
OE no: 662529-12
Dinex no: 1JX001
OE no: 662529-13
Type: NOX Sensor

Dinex no: 1JX004
OE no: 662529-16
Type: Pressure Sensor

Dinex no: 1JT000
OE no: 662529-21
Type: Injector for AdBlue®

Accessories

No.	Dinex no	OE no	Type
1.	1JL004	661268	Clamp
2.	1JL008	661327	Gasket
3.	1JL003	661616	Clamp
4.	1JL002	661617	Gasket
5.	1JL010	660941	Clamp
6.	1JL011	661548	Gasket

Dinex diesel particulate filter kit

Dinex no: 2AI003 / New
Dinex no: 2AI003-RX / Reconditioned



OE no: 2274555
Type: Diesel Particle Filter
Technology: HP-SiC

Dinex no: 6LL011
Type: Clamp

Dinex no: 6LL012
Type: Gasket

Kit number: 2AI022
OE no: 1976845



Content IVECO

A one-box ATS system with cordierite DPF, DOC, and SCR coupled with an insulated front pipe for maximum heat retention and emission reduction efficiency. DPF has easy access for replacement or maintenance. Dinex also offers a wide range of exhaust pipes and other parts related to the exhaust system for Iveco city buses and coaches.

Type/Model

CITELIS / CREALIS EURO 5	19
CROSSWAY / EVADYS EURO 5	20
DOMINO EURO 5	21
CROSSWAY HV EURO 6	22
CROSSWAY LE EURO 6	23
CROSSWAY LE EURO 6	24
URBANWAY EURO 6	25
MAGELYS/ARWAY	26
EVADYS EURO 6	27

EURO 5

4x2



Vehicle engine

Cursor 8

7,8 ltr. / 6 cyl.

182KW / 245HP

216KW / 290HP

283KW / 380HP

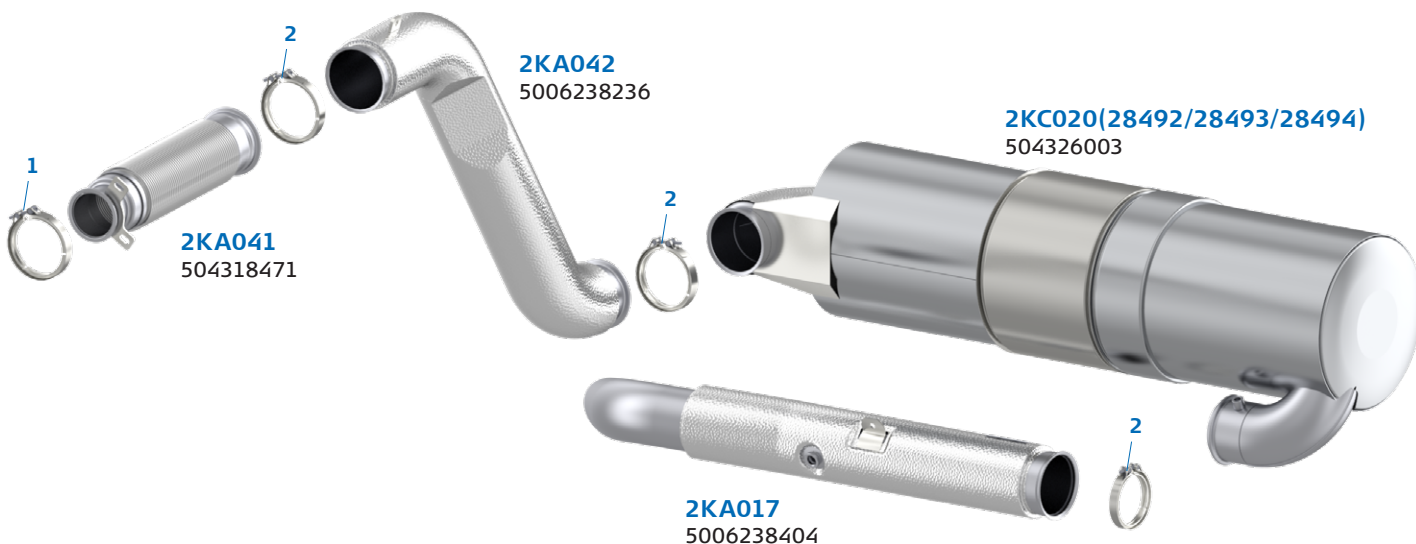

Mechatronics



Dinex no: 2KP003
OE no: 500059690, 500061334, 503138997, 504200399
Type: Pump for AdBlue®



Dinex no: 2KT002
OE no: 5801392767
Type: Injector for AdBlue®



Dinex no: 29042
OE no: 504109529
Dinex no: 29043
OE no: 504102603
Type: Temperature Sensor



Dinex no: 29030
OE no: 5801754015
Type: NOx Sensor

Accessories

No.	Dinex no	OE no	Type
1.	2KL039	500390639	Clamp
2.	2KL026	17038125	Clamp

EURO 5

4x2



Vehicle engine

Cursor 8
7,8 ltr. / 6 cyl.
 243KW / 330HP
 280KW / 380HP

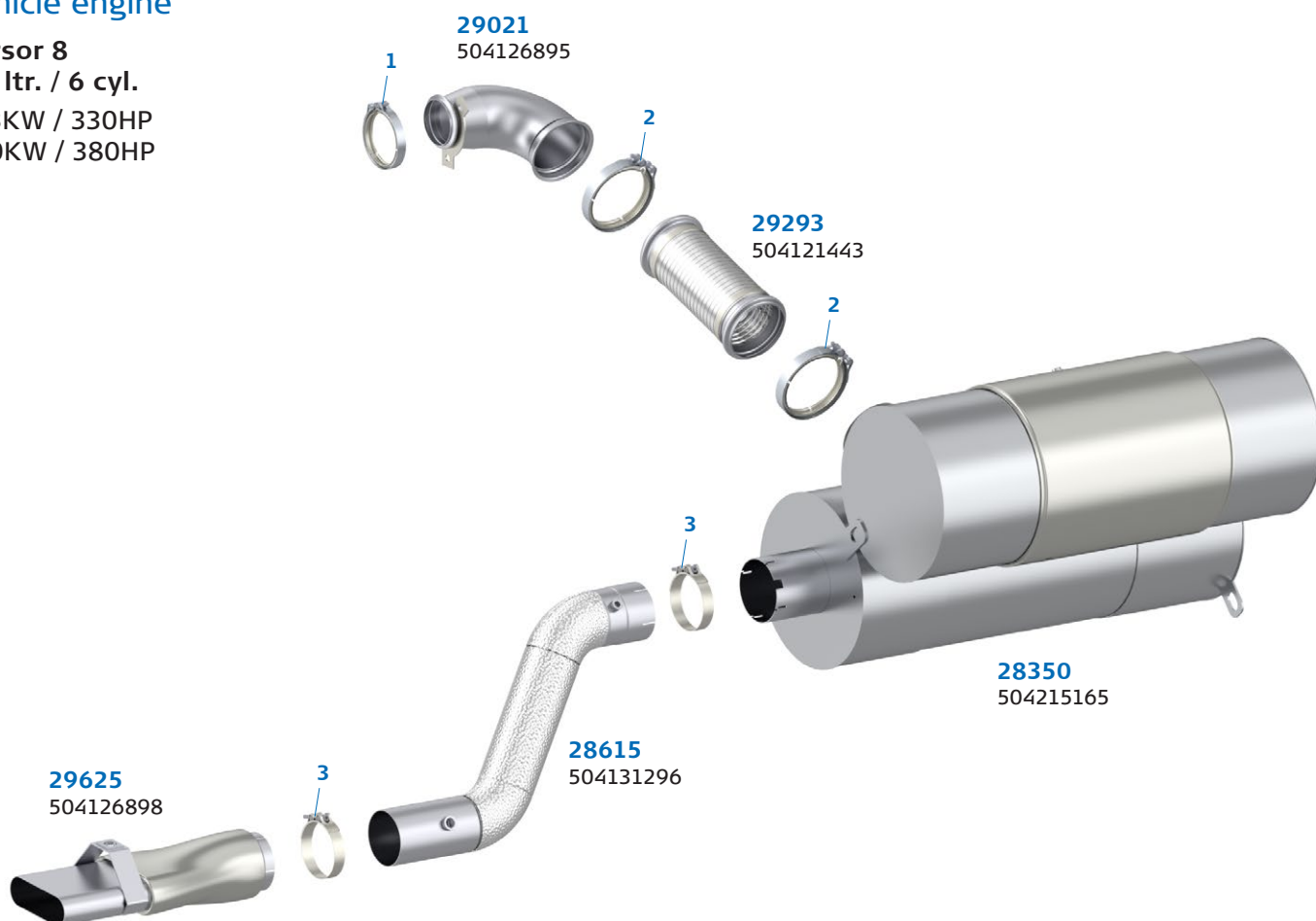

Manufacturers part numbers are quoted for reference only.

Mechatronics



Dinex no: 29043
OE no: 504102603
Dinex no: 29048
OE no: 504236065
Type: Temperature Sensor



Dinex no: 29030
OE no: 5801754015
Type: NOx Sensor



Dinex no: 2KP003
OE no: 500059690,
 500061334, 503138997,
 504200399
Type: Pump for AdBlue®



Dinex no: 2KT008
OE no: 41271148
Type: Injector for AdBlue®

Accessories

No.	Dinex no	OE no	Type
1.	2KL039	500390639	Clamp
2.	2KL026	17038125	Clamp
3.	99214	18150294	Clamp

EURO 5

4x2 - 6x2



Vehicle engine

Cursor 8

7,8 ltr. / 6 cyl.

182KW / 245HP

216KW / 290HP

283KW / 380HP

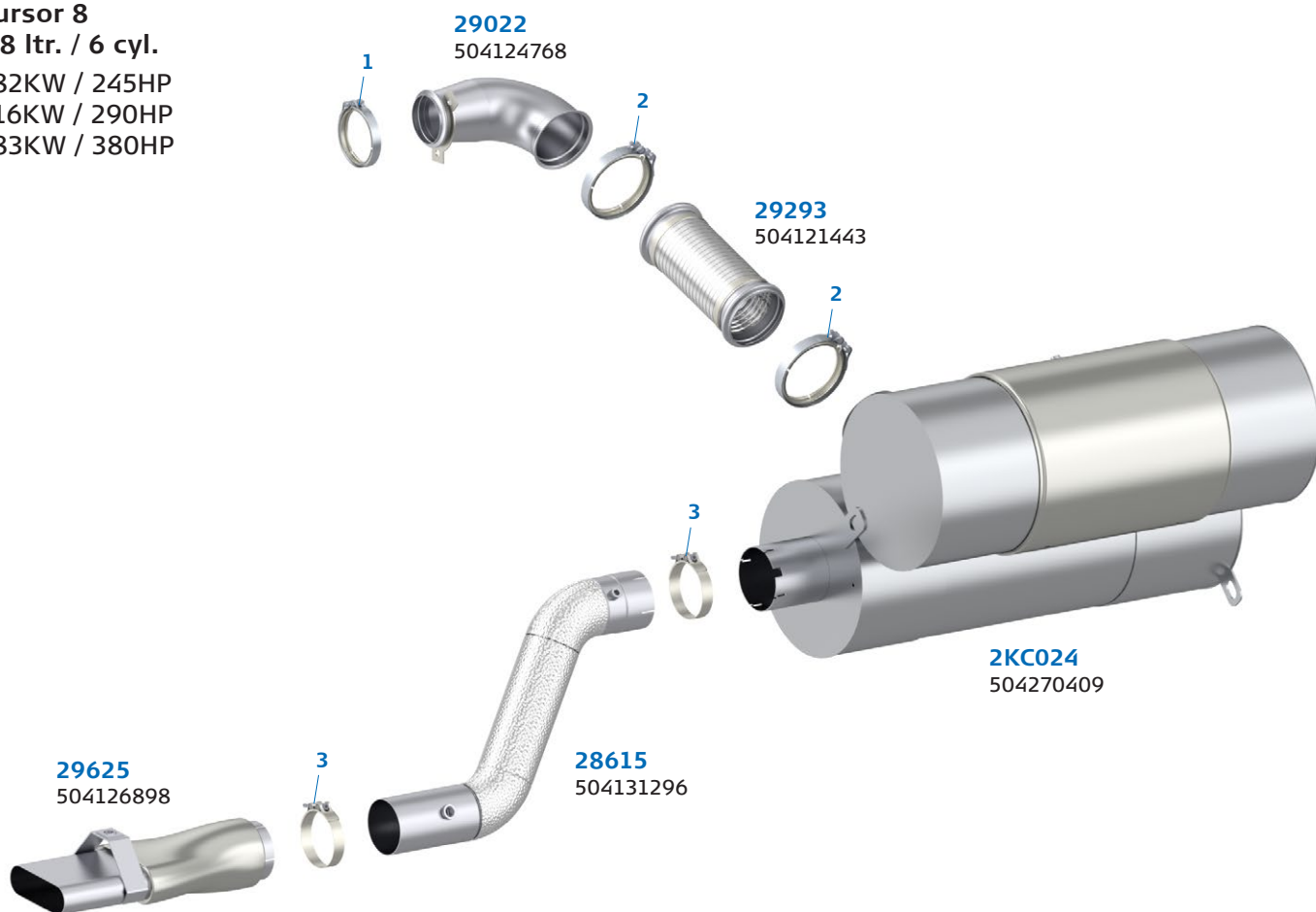

Mechatronics



Dinex no: 29043
OE no: 504102603
Dinex no: 29048
OE no: 504236065
Type: Temperature Sensor



Dinex no: 29030
OE no: 5801754015
Type: NOx Sensor



Dinex no: 2KP003
OE no: 500059690,
500061334, 503138997,
504200399
Type: Pump for AdBlue®



Dinex no: 2KT002
OE no: 5801392767
Type: Injector for AdBlue®

Accessories

No.	Dinex no	OE no	Type
1.	2KL039	500390639	Clamp
2.	2KL026	17038125	Clamp
3.	99214	18150294	Clamp

EURO 6

4x2



Vehicle engine

Tector 7
6,7 ltr. / 6 cyl.
210KW/286HP
228KW/320HP



Built-in substrates

DOC
9AA048

SCR with ASC
9AA091

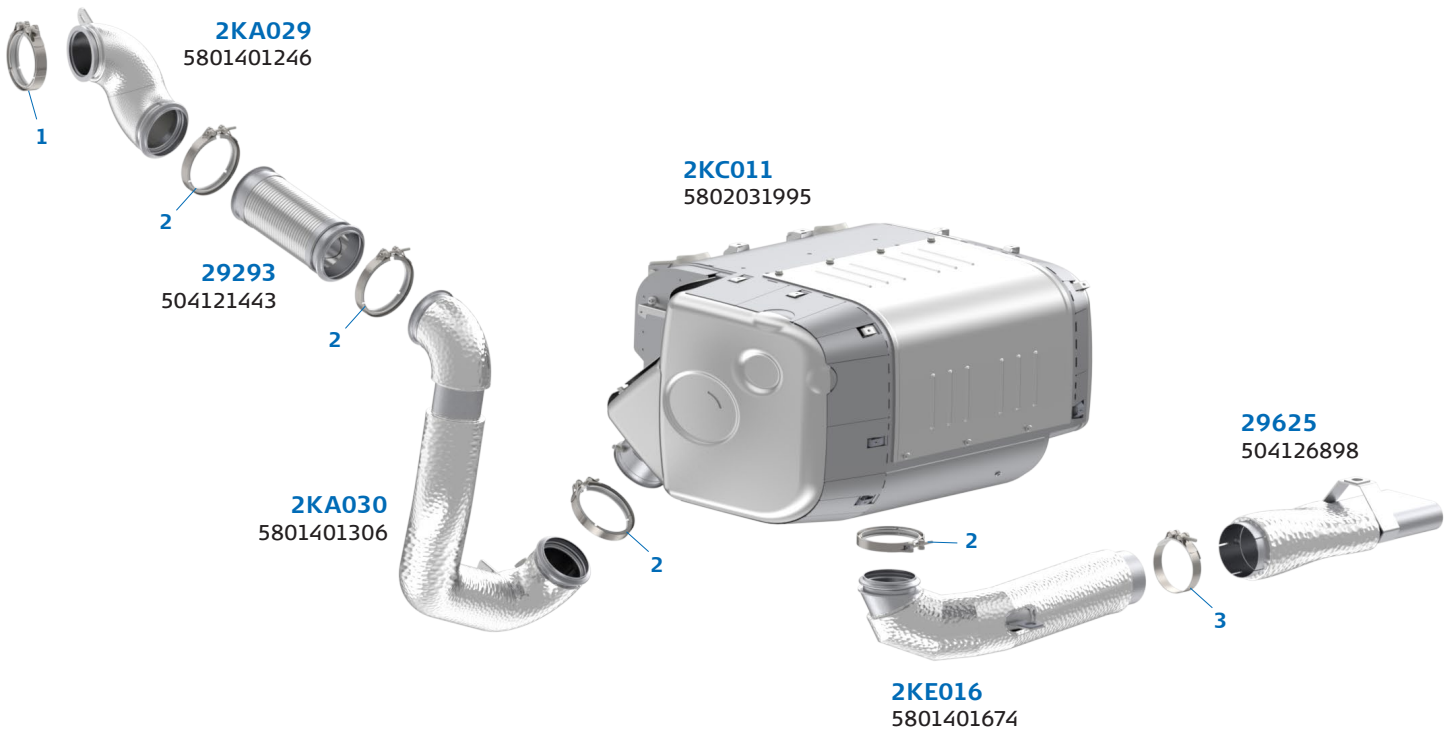

Dinex diesel particulate filter kit

Dinex no: 2KI015 / New
Dinex no: 2KI015-RX / Reconditioned



OE no: 5801651208
Type: Diesel Particle Filter



Dinex no: 2KL030
Type: Clamp



Dinex no: 2KL029
Type: Clamp



Dinex no: 2KL028
Type: Gasket

Kit number: 2KL017
OE no: 5801651206

Mechatronics



Dinex no: 29043
OE no: 5801455940,
504102603
Dinex no: 29042
OE no: 5801455941
Type: Temperature Sensor



Dinex no: 29031
OE no: 5801627702,
5801429373
Dinex no: 29032
OE no: 5801754014,
5801627703
Type: NOx Sensor



Dinex no: 29050
OE no: 5801792376
Type: Pressure Sensor

Accessories

No.	Dinex no	OE no	Type
1.	2KL040	5006210992	Clamp
2.	2KL026	17038125	Clamp
3.	2KL024	5801596959	Clamp



Dinex no: 2KP000
OE no: 504381868,
5802513619, 5802855457
Type: Pump for AdBlue®



Dinex no: 2KT009
OE no: 5801755285
Type: Injector for AdBlue®

EURO 6

4x2



Vehicle engine

Tector 7
6,7 ltr. / 6 cyl.
210KW/286HP
228KW/320HP



Built-in substrates

DOC
9AA048



SCR with ASC
9AA091

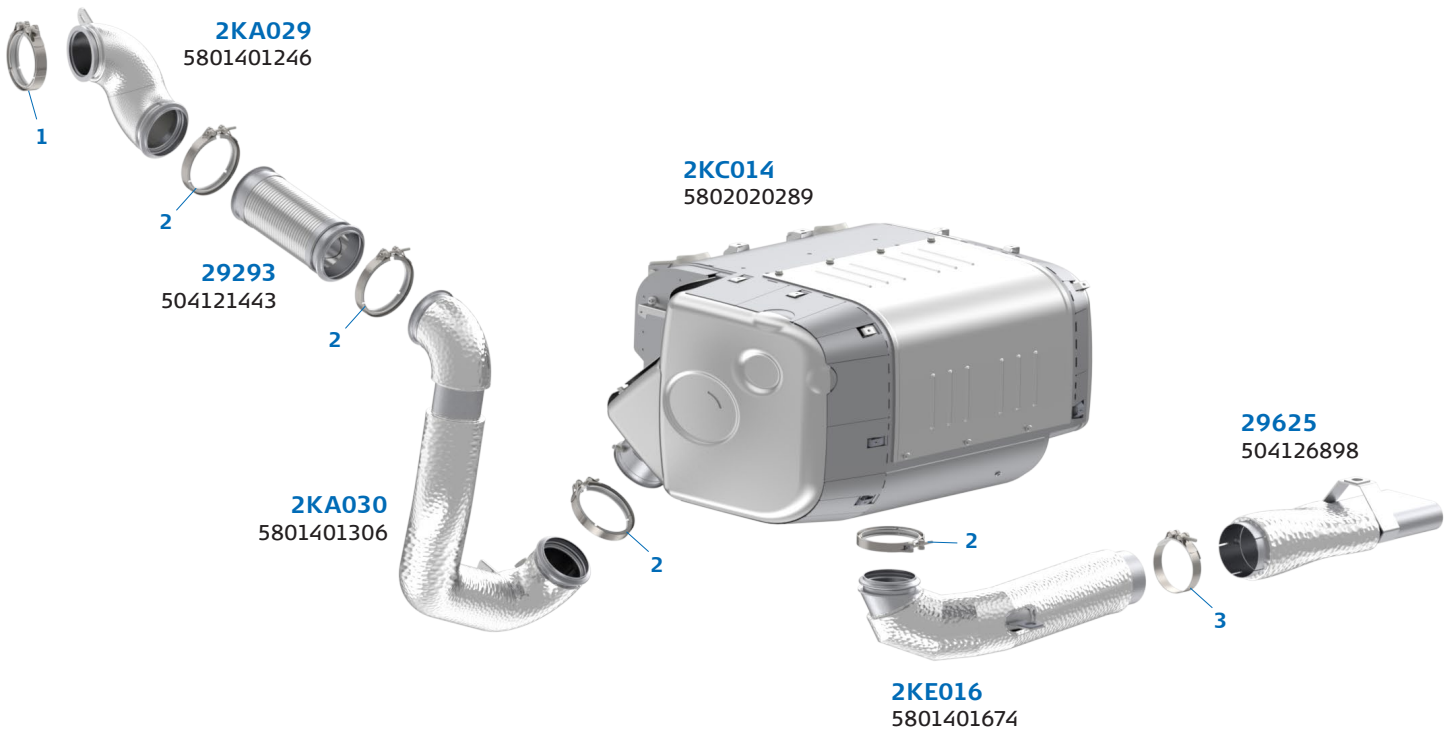

Dinex diesel particulate filter kit

Dinex no: 2KI017 / New
Dinex no: 2KI017-RX / Reconditioned



OE no: 5802020368
Type: Diesel Particle Filter



Dinex no: 2KL030
Type: Clamp



Dinex no: 2KL029
Type: Clamp



Dinex no: 2KL028
Type: Gasket

Kit number: 2KL017
OE no: 5801651206

Mechatronics



Dinex no: 29043
OE no: 5801455940,
504102603
Dinex no: 29042
OE no: 5801455941
Type: Temperature Sensor



Dinex no: 29031
OE no: 5801627702,
5801429373
Dinex no: 29032
OE no: 5801754014,
5801627703
Type: NOx Sensor



Dinex no: 29050
OE no: 5801792376
Type: Pressure Sensor

Accessories

No.	Dinex no	OE no	Type
1.	2KL040	5006210992	Clamp
2.	2KL026	17038125	Clamp
3.	2KL024	5801596959	Clamp



Dinex no: 2KP000
OE no: 504381868,
5802513619, 5802855457
Type: Pump for AdBlue®



Dinex no: 2KT009
OE no: 5801755285
Type: Injector for AdBlue®



Built-in substrates

DOC
9AA048



SCR with ASC
9AA091

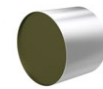

EURO 6

4x2



Vehicle engine

Tector 7
6,7 ltr. / 6 cyl.
210KW / 286HP



2KC011
5802031995



2KG016
5801522321



2KE018
5801522320



2KE017
5801520998

29293
504121443



2KA031
580152 0993

Dinex diesel particulate filter kit

Dinex no: 2KI015 / New
Dinex no: 2KI015-RX / Reconditioned



OE no: 5801651208
Type: Diesel Particle Filter



Dinex no: 2KL030
Type: Clamp



Dinex no: 2KL029
Type: Clamp



Dinex no: 2KL028
Type: Gasket

Kit number: 2KL017
OE no: 5801651206

Mechatronics



Dinex no: 29043
OE no: 5801455940,
504102603
Dinex no: 29042
OE no: 5801455941
Type: Temperature Sensor



Dinex no: 29031
OE no: 5801627702,
5801429373
Dinex no: 29032
OE no: 5801754014,
5801627703
Type: NOx Sensor



Dinex no: 29050
OE no: 5801792376
Type: Pressure Sensor

Accessories

No.	Dinex no	OE no	Type
1.	2KL040	5006210992	Clamp
2.	2KL026	17038125	Clamp



Dinex no: 2KP000
OE no: 504381868,
5802513619, 5802855457
Type: Pump for AdBlue®



Dinex no: 2KT009
OE no: 5801755285
Type: Injector for AdBlue®

EURO 6

6x2



Vehicle engine

Cursor 9

8,7 ltr. / 6 cyl.

265KW / 360HP



Built-in substrates

DOC
9AA029

SCR with ASC
9AA090



2KC000
5801429216



2KA058
5801437995

29293
504121443

2KA027
5801437998

2KE013
5801437996

2KE015
5801437997

29625
504126898



Dinex diesel particulate filter kit

Dinex no: 2KI000 / New
Dinex no: 2KI000-RX / Reconditioned



OE no: 5801651186
Type: Diesel Particle Filter



Dinex no: 2KL014
Type: Clamp



Dinex no: 2KL015
Type: Clamp



Dinex no: 2KL016
Type: Gasket

Kit number: 2KI000
OE no: 5801651134

Mechatronics



Dinex no: 29043
OE no: 5801455940,
504102603
Dinex no: 29042
OE no: 5801455941
Type: Temperature Sensor



Dinex no: 29031
OE no: 5801627702,
5801429373
Dinex no: 29032
OE no: 5801754014,
5801627703
Type: NOx Sensor



Dinex no: 29050
OE no: 5801792376
Type: Pressure Sensor

Accessories

No.	Dinex no	OE no	Type
1.	2KL024	5801596959	Clamp
2.	2KL025	5801623568	Clamp
3.	99202	5801640811	Clamp
4.	2KL026	17038125	Clamp
5.	29806	41201881	Clamp



Dinex no: 2KP000
OE no: 504381868,
5802513619, 5802855457
Type: Pump for AdBlue®



Dinex no: 2KT009
OE no: 5801755285
Type: Injector for AdBlue®

EURO 6

4x2



Vehicle engine

Cursor 9
8,7 ltr. / 6 cyl.
294KW / 400HP



Built-in substrates

DOC
9AA029



SCR with ASC
9AA090

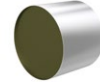

2KC001
5801429215



2KA058
5801437995



29293
504121443



2KA027
5801437998



2KE013
5801437996



2KE015
5801437997



29625
504126898



Dinex diesel particulate filter kit

Dinex no: 2KI002 / New
Dinex no: 2KI002-RX / Reconditioned

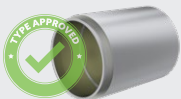

OE no: 5801651187
Type: Diesel Particle Filter



Dinex no: 2KL014
Type: Clamp



Dinex no: 2KL015
Type: Clamp



Dinex no: 2KL016
Type: Gasket

Kit number: 2KJ000
OE no: 5801651134

Mechatronics



Dinex no: 29043
OE no: 5801455940,
504102603
Dinex no: 29042
OE no: 5801455941
Type: Temperature Sensor



Dinex no: 29031
OE no: 5801627702,
5801429373
Dinex no: 29032
OE no: 5801754014,
5801627703
Type: NOx Sensor



Dinex no: 29050
OE no: 5801792376
Type: Pressure Sensor

Accessories

No.	Dinex no	OE no	Type
1.	2KL024	5801596959	Clamp
2.	2KL025	5801623568	Clamp
3.	99202	5801640811	Clamp
4.	2KL026	17038125	Clamp
5.	29806	41201881	Clamp



Dinex no: 2KP000
OE no: 504381868,
5802513619, 5802855457
Type: Pump for AdBlue®



Dinex no: 2KT009
OE no: 5801755285
Type: Injector for AdBlue®

EURO 6

4x2



Vehicle engine

Cursor 9
8,7 ltr. / 6 cyl.
294KW / 400HP



Built-in substrates

DOC
9AA029



SCR with ASC
9AA090

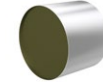

2KC015
5801953676



2KA058
5801437995



29293
504121443



2KA027
5801437998



2KE013
5801437996



2KE015
5801437997



29625
504126898



Dinex diesel particulate filter kit

Dinex no: 2KI004 / New
Dinex no: 2KI004-RX / Reconditioned



OE no: 5802041639
Type: Diesel Particle Filter

Dinex no: 2KL014
Type: Clamp

Dinex no: 2KL015
Type: Clamp

Dinex no: 2KL016
Type: Gasket

Kit number: 2KJ000
OE no: 5801651134

Mechatronics



Dinex no: 29043
OE no: 5801455940,
504102603
Dinex no: 29042
OE no: 5801455941
Type: Temperature Sensor



Dinex no: 29031
OE no: 5801627702,
5801429373
Dinex no: 29032
OE no: 5801754014,
5801627703
Type: NOx Sensor



Dinex no: 29050
OE no: 5801792376
Type: Pressure Sensor

Accessories

No.	Dinex no	OE no	Type
1.	2KL024	5801596959	Clamp
2.	2KL025	5801623568	Clamp
3.	99202	5801640811	Clamp
4.	2KL026	17038125	Clamp
5.	29806	41201881	Clamp



Dinex no: 2KP000
OE no: 504381868,
5802513619, 5802855457
Type: Pump for AdBlue®



Dinex no: 2KT009
OE no: 5801755285
Type: Injector for AdBlue®



MAN

Content **MAN**

A very compact and lightweight one-box ATS system. Designed for easy maintenance, this one-box solution combines ATS efficiency together with an easily replaceable DPF unit. The result is smooth, prolonged operation with emission reduction that matches the OE level. All parts are from stainless steel to ensure the lifetime of the exhaust system. Dinex also offers all exhaust pipes and other parts related to the exhaust system for MAN city buses and coaches.

Type/Model

CITYLINER / TOURLINER / LION'S COACH / STARLINER.....	29
LION 4 CITY 12M / 18M / 13M / 19M.....	31
LIONS CITY	32
JETLINER / JETLINER C	33
TOURLINER C.....	34
LION'S COACH / SKYLINER / SKYLINER L.....	35

EURO 5 - Horizontal

4x2



Vehicle engine

D2066 LOH
10,5 ltr. / 6 cyl.
 235KW / 320HP
 265KW / 360HP

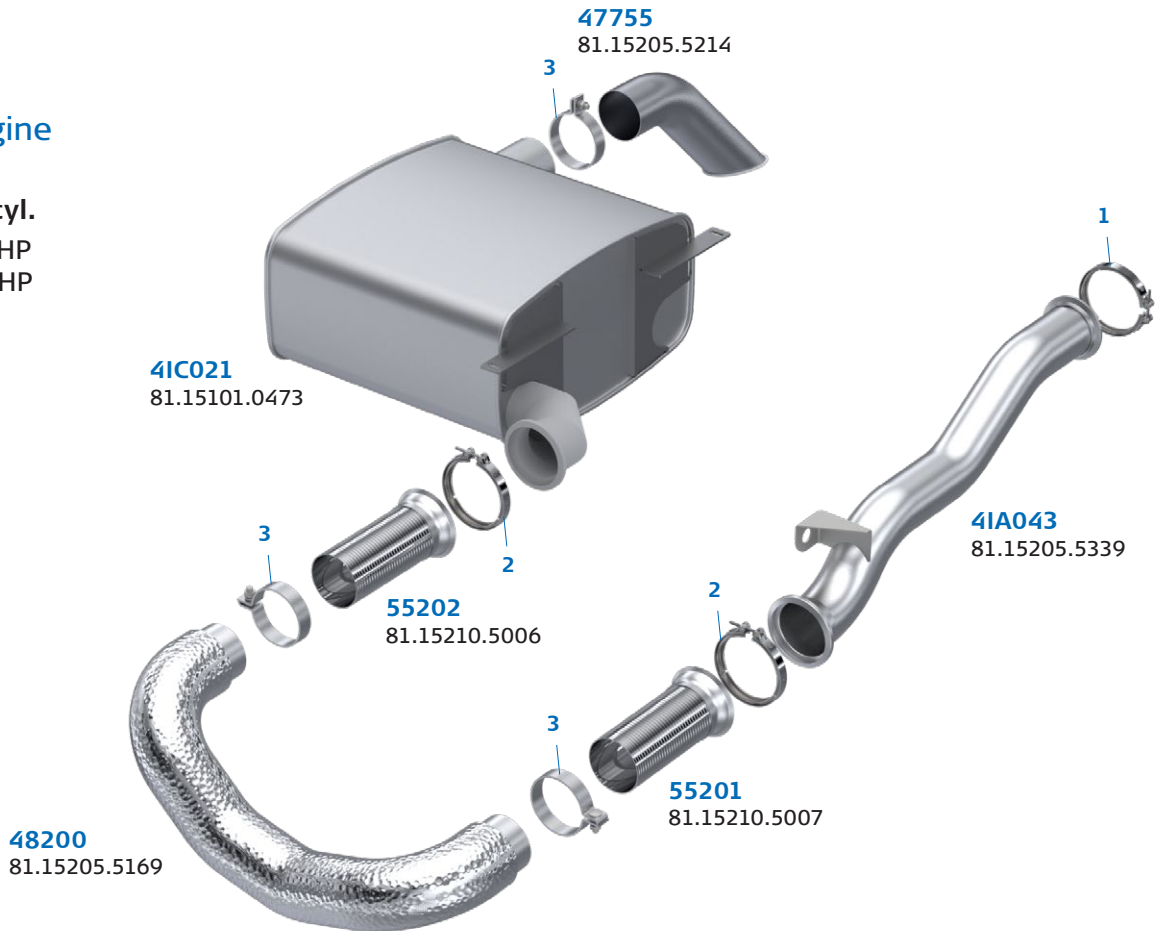

Mechatronics



Dinex no: 47043
OE no: 81.27421.0263
Type: Temperature Sensor



Dinex no: 47030
OE no: 51.15408.0009
Type: NOx Sensor



Dinex no: 47054
OE no: 51.27421.0223
Type: Pressure Sensor

Accessories

No.	Dinex no	OE no	Type
1.	4IL040	51.97445.0073	Clamp
2.	80921	06.67410.4153	Clamp
3.	99714	81.97420.0152	Clamp

EURO 5 - Horizontal

4x2



Vehicle engine

D2676 LOH
12,4 ltr. / 6 cyl.
 324KW/440HP
 353KW/480HP
 371KW/505HP

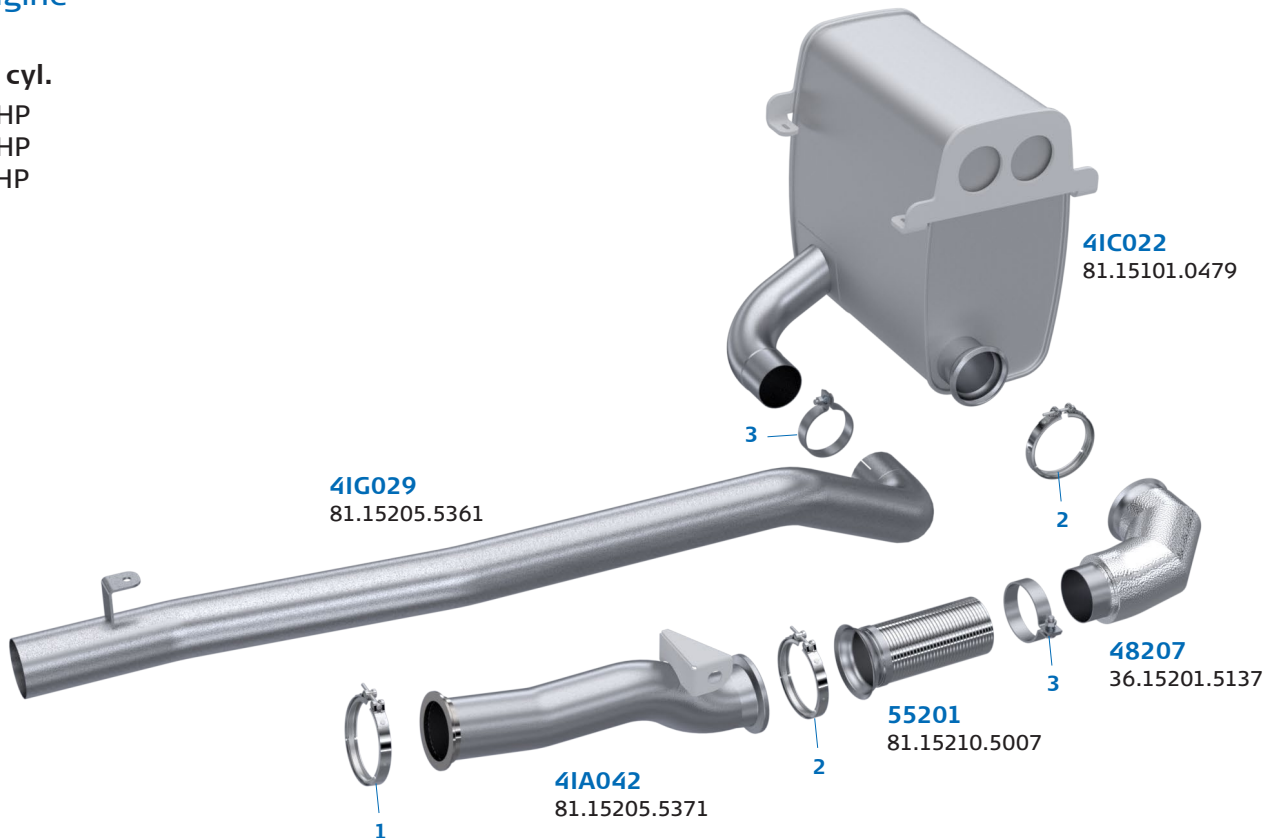

Mechatronics



Dinex no: 47043
OE no: 81.27421.0263
Type: Temperature Sensor



Dinex no: 47030
OE no: 51.15408.0009
Type: NOx Sensor



Dinex no: 47054
OE no: 51.27421.0223
Type: Pressure Sensor

Accessories

No.	Dinex no	OE no	Type
1.	4IL040	51.97445.0073	Clamp
2.	80921	06.67410.4153	Clamp
3.	99714	81.97420.0152	Clamp

EURO 6 - Horizontal

4x2



Vehicle engine

D0836 LOH
6,9 ltr. / 6 cyl.
213 kW / 290 hp

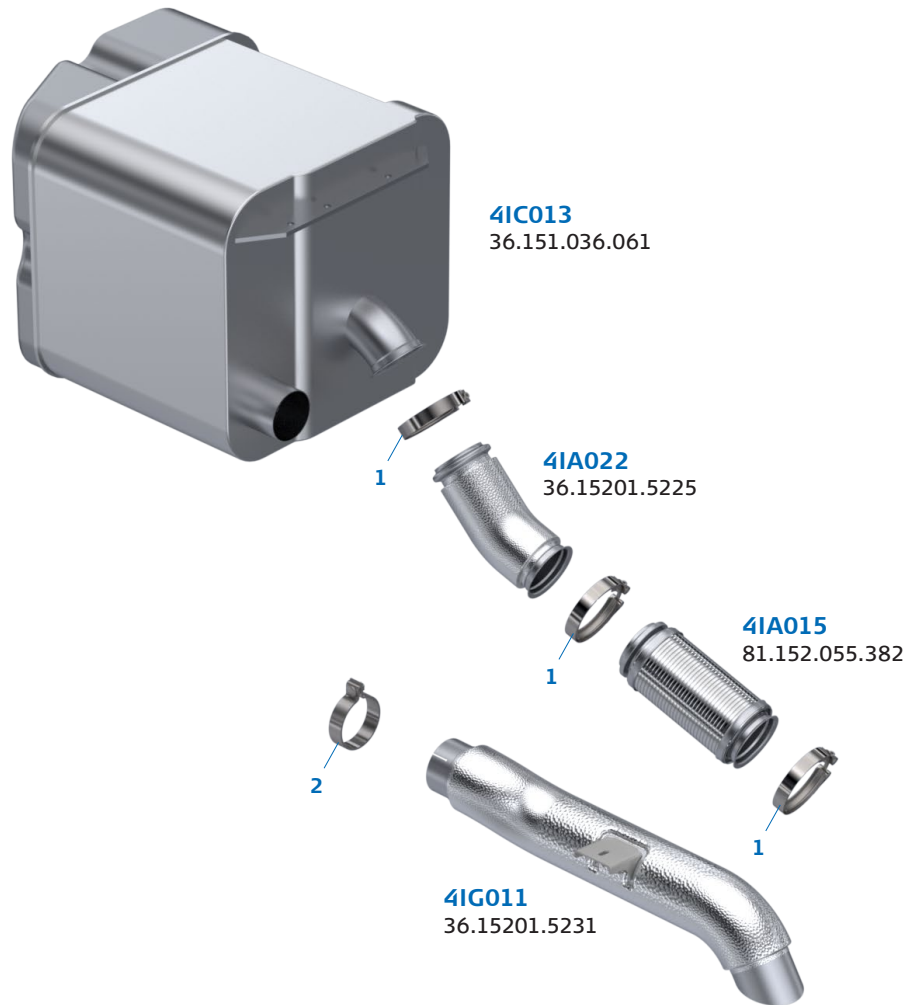

Mechatronics



Dinex no: 47045
OE no: 51.27421.0343
Type: Temperature Sensor



Dinex no: 4IL018
OE no: 51.15408-0018
Dinex no: 47032
OE no: 51.15408.0019
Type: NOx Sensor



Dinex no: 47051
OE no: 51.27421.0331
Type: Pressure Sensor

Accessories

No.	Dinex no	OE no	Type
1.	4IL027	66.7434.8127	Clamp
2.	99700	81.97450.0034	Clamp



Dinex no: 4IP004
OE no: 81.15403.6150,
 81.15403.6145, 81.15403.6147
Type: Pump for AdBlue®



Dinex no: 4IT000
OE no: 81.15405.6011,
 81.15405.6012
Type: Injector for AdBlue®

Dinex diesel particulate filter

Dinex no: 4II015 / New
Dinex no: 4II015-RX / Reconditioned



OE no: 81.15103.0162
Type: Diesel Particle Filter

EURO 6 - Horizontal

4x2



Vehicle engine

D2066 LUH
10,5 ltr. / 6 cyl.
 206KW / 280HP
 235KW / 320HP



Built-in substrates

SCR with ASC
41014

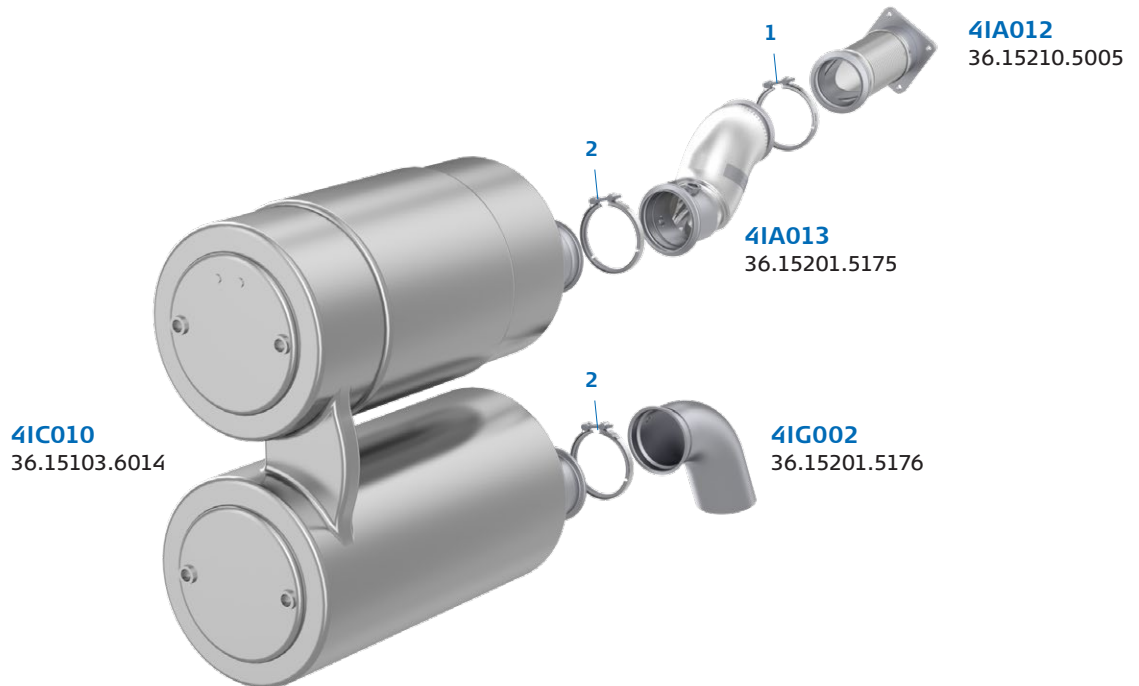

41C010
36.15103.6014

41A012
36.15210.5005

41A013
36.15201.5175

41G002
36.15201.5176

Dinex diesel particulate filter kit

Dinex no: 41I001 / New
 Dinex no: 41I001-RX / Reconditioned



OE no: 81.15103.0107,
81.15103.9107,81.15103.0128
Type: Diesel Particle Filter

Kit number: 41J005



Dinex no: 41L053
OE no: 36.97420.0005
Type: Clamp



Dinex no: 41L055
OE no: 36.15103.0010
Type: Gasket



Dinex no: 41L054
OE no: 36.15103.0009
Type: Gasket



Dinex no: 41L061
OE no: 36.15103.0011
Type: Ring

Mechatronics



Dinex no: 47045
OE no: 51.27421.0343
Type: Temperature Sensor



Dinex no: 41L018
OE no: 51.15408.0018
Dinex no: 47032
OE no: 51.15408.0019
Type: NOx Sensor



Dinex no: 47051
OE no: 51.27421.0331
Type: Pressure Sensor

Accessories

No.	Dinex no	OE no	Type
1.	41L027	06.67434.8127	Clamp
2.	68835	06.67419.0006	Clamp



Dinex no: 41P007
OE no: 81.15403.6139
Type: Pump for AdBlue®



Dinex no: 41T020
OE no: 36.15405.5000
Type: Injector for AdBlue®

EURO 6 - Horizontal

4x2



Vehicle engine

D2066 LUH
10,5 ltr. / 6 cyl.
 206KW / 280HP
 235KW / 320HP
 264KW / 360HP
 294KW / 400HP



Built-in substrates

SCR with ASC
411014



Dinex diesel particulate filter kit

Dinex no: 411001 / New
 Dinex no: 411001-RX / Reconditioned



OE no: 81.15103.0107,
 81.15103.9107,81.15103.0128
 Type: Diesel Particle Filter

Kit number: 411005



Dinex no: 41L053
 OE no: 36.97420.0005
 Type: Clamp

Dinex no: 41L055
 OE no: 36.15103.0010
 Type: Gasket

Dinex no: 41L054
 OE no: 36.15103.0009
 Type: Gasket

Dinex no: 41L061
 OE no: 36.15103.0011
 Type: Ring

Mechatronics



Dinex no: 47046
 OE no: 51.27421.0342
 Type: Temperature Sensor



Dinex no: 47031
 OE no: 51.15408.0017
 Dinex no: 47034
 OE no: 51.15408.0016
 Type: NOx Sensor



Dinex no: 47051
 OE no: 51.27421.0331
 Type: Pressure Sensor

Accessories

No.	Dinex no	OE no	Type
1.	41L027	06.67434.8127	Clamp
2.	68835	06.67419.0006	Clamp
3.	70804	06.67419.0009	Clamp



Dinex no: 41P007
 OE no: 81.15403.6139
 Type: Pump for AdBlue®



Dinex no: 41T020
 OE no: 36.15405.5000
 Type: Injector for AdBlue®

EURO 6 - Horizontal

4x2 - 6x2



Vehicle engine

D2676 LOH36
12,4 ltr. / 6 cyl.
 316KW / 430HP
 346KW / 470HP
 375KW / 510HP



Built-in substrates

DOC
9AA032



SCR with ASC
9AA092



4IC015
36.15103.6058



4IA040
36.15201.5251

4IA000
81.15210.5016

4IG019
36.15201.5243

4IA039
36.15201.5254

Dinex diesel particulate filter kit

Dinex no: 4II001 / New
 Dinex no: 4II001-RX / Reconditioned



OE no: 81.15103.0107,
81.15103.9107,81.15103.0128
Type: Diesel Particle Filter



Kit number: 4II007
 x 2

Dinex no: 4IL004
OE no: 81.97420.0184
Type: Clamp

Dinex no: 4IL003
OE no: 81.15901.0043
Type: Gasket

Dinex no: 4IL059
OE no: 81.97420.0196
Type: Clamp

Dinex no: 4IL060
OE no: 81.15901.0051
Type: Gasket

Mechatronics



Dinex no: 47053
OE no: 51.27421.0312
Type: Temperature Sensor



Dinex no: 47034
OE no: 51.15408.0016
Dinex no: 47035
OE no: 51.15408.0028
Type: NOx Sensor



Dinex no: 47051
OE no: 51.27421.0331
Type: Pressure Sensor

Accessories

No.	Dinex no	OE no	Type
1.	68835	06.67419.0006	Clamp
2.	4IL002	81.15901.0042	Gasket
3.	4IL039	06.67434.9144	Clamp
4.	4IL026	36.15901.0003	Gasket
5.	4IL027	06.67434.8127	Clamp



Dinex no: 4IP004
OE no: 81.15403.6150,
81.15403.6145, 81.15403.6147
Type: Pump for AdBlue®



Dinex no: 4IT021
OE no: 81.15405.6009
Type: Injector for AdBlue®

EURO 6 - Horizontal

4x2 - 6x2



Vehicle engine

D2676 LOH36
12,4 ltr. / 6 cyl.
 316KW / 430HP
 346KW / 470HP
 375KW / 510HP

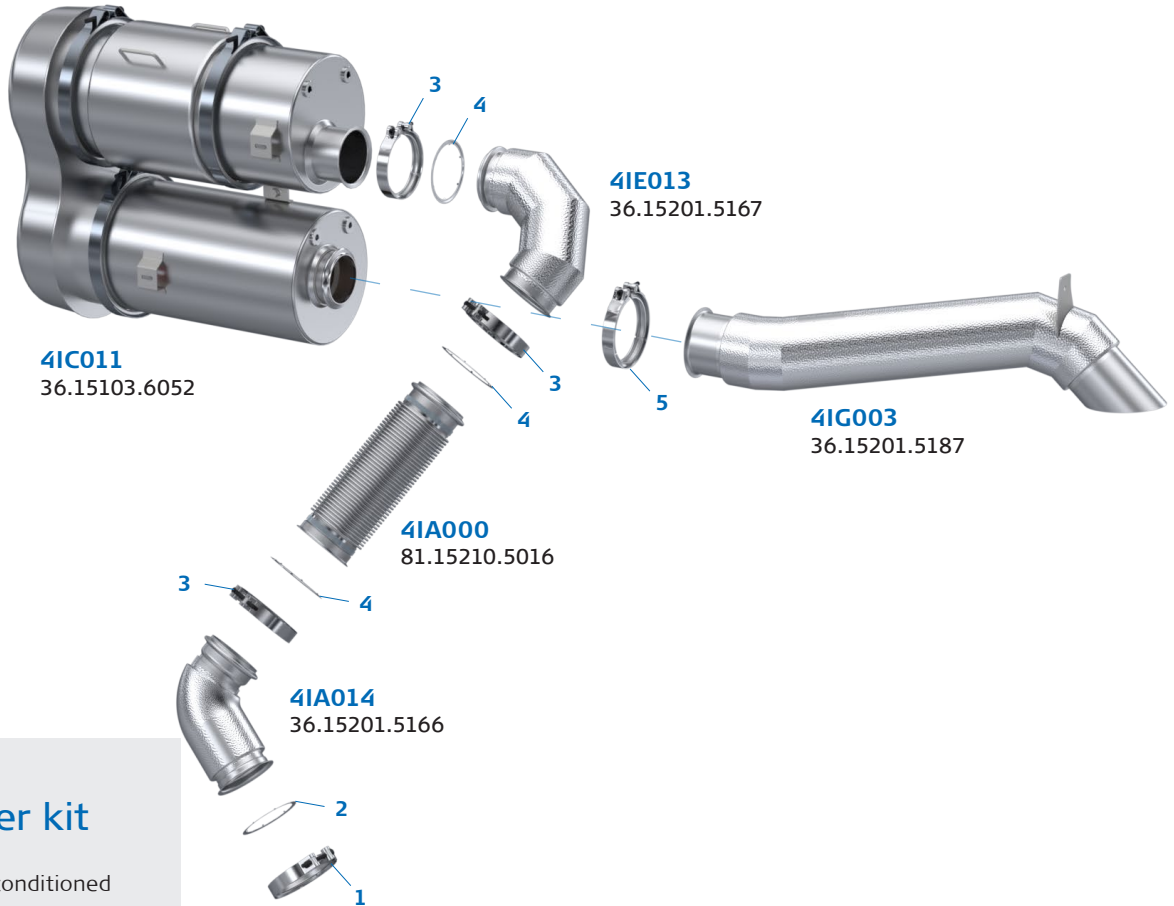

Dinex diesel particulate filter kit

Dinex no: 4II001 / New
 Dinex no: 4II001-RX / Reconditioned



OE no: 81.15103.0107, 81.15103.9107, 81.15103.0128
Type: Diesel Particle Filter

Kit number: 4II006



Dinex no: 4IL004
OE no: 81.97420.0184
Type: Clamp



Dinex no: 4IL003
OE no: 81.15901.0043
Type: Gasket



Dinex no: 4IL063
OE no: 36.15103.0034
Type: Gasket



Dinex no: 4IL062
OE no: 36.97420.0007
Type: Clamp



Dinex no: 4IL064
OE no: 36.15103.0037
Type: Clamp



Dinex no: 4IL065
OE no: 36.15103.6033
Type: Ring

Mechatronics



Dinex no: 47053
OE no: 51.27421.0312
Type: Temperature Sensor



Dinex no: 47034
OE no: 51.15408.0016
Type: NOx Sensor



Dinex no: 47051
OE no: 51.27421.0331
Type: Pressure Sensor

Accessories

No.	Dinex no	OE no	Type
1.	4IL027	06.67434.8127	Clamp
2.	4IL026	36.15901.0003	Gasket
3.	68835	06.67419.0006	Clamp
4.	4IL002	81.15901.0042	Gasket
5.	4IL039	06.67434.9144	Clamp



Dinex no: 4IP004
OE no: 81.15403.6150, 81.15403.6145, 81.15403.6147
Type: Pump for AdBlue®



Dinex no: 4IT021
OE no: 81.15405.6009
Type: Injector for AdBlue®



MERCEDES



Content MERCEDES

A truly unique ATS solution comprising a replaceable, high quality silicon-carbide DPF for more soot capacity with a PGM loading on the same level as OE and DOC and SCR for the highest NOx reduction. Silicon-carbide DPF gives a more durable, effective DPF solution. Dinex also offers a wide range of exhaust pipes and other parts related to exhaust systems for Mercedes city buses and coaches.

Type/Model

CONNECTO	37
CITARO	38
CITARO 1	39
CITARO LE	40
CITARO G	41
CITARO G / CONNECTO G	42
INTEGRO / INTOURO / INTOURO M / INTOURO L	43
INTEGRO L / TOURISMO / TRAVEGO / SETRA	44

EURO 6

4x2



Vehicle engine

OM936 H

7,7 ltr. / 6 cyl.

175KW / 238HP

200KW / 272HP

220KW / 299HP



Built-in substrates

DOC
9AA035



SCR with ASC
9AA094

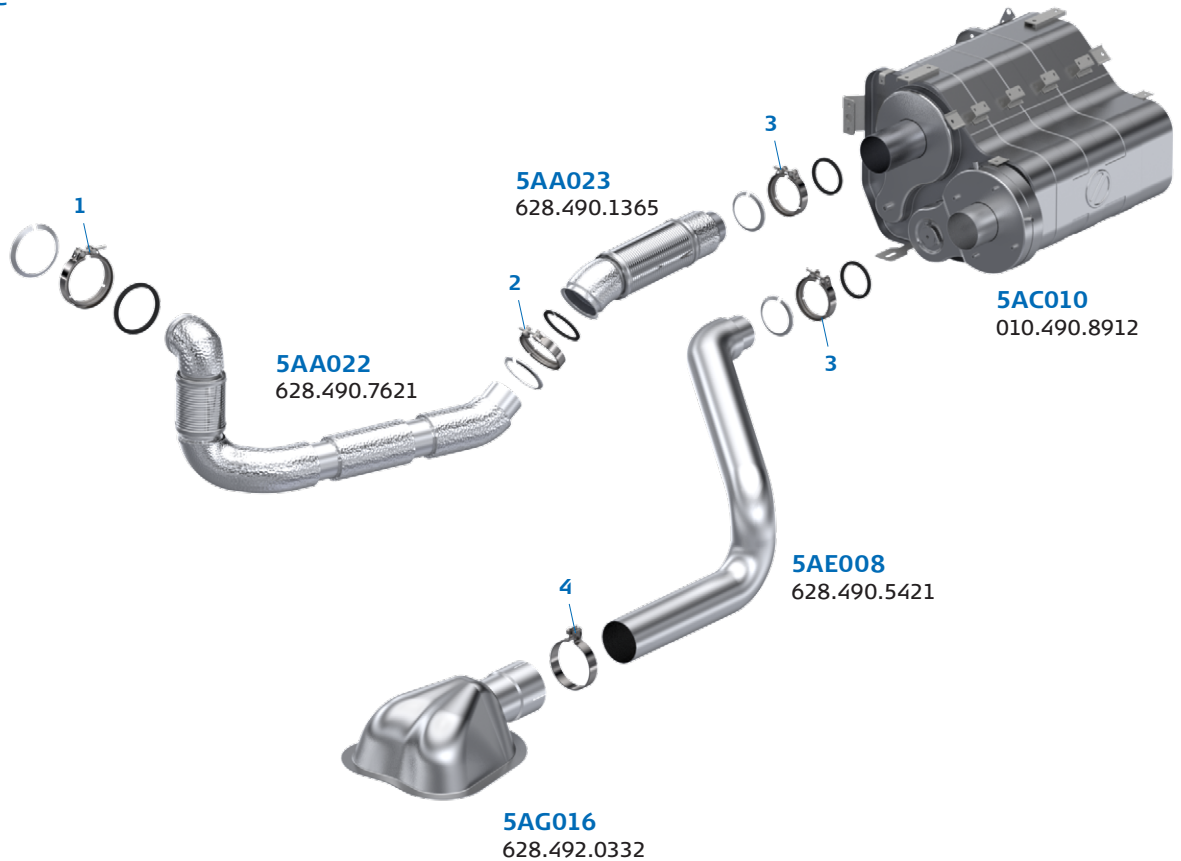
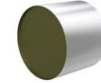

Mechatronics

Dinex no: 51073
OE no: 008.542.4618
Dinex no: 51074
OE no: 009.542.8918
Dinex no: 51075
OE no: 009.542.8418
Dinex no: 51076
OE no: 009.542.8818
Type: Temperature Sensor



Dinex no: 51027
OE no: 009.153.0128
Dinex no: 51035
OE no: 008.1539.928
Type: NOx Sensor



Dinex no: 51050
OE no: 01.0153.0028
Dinex no: 51051
OE no: 01.0153.0228
Type: Pressure Sensor



Accessories

No.	Dinex no	OE no	Type
1.	5AL011	001.995.0702	Clamp Kit
2.	5AL013	002.995.7102	Clamp Kit
3.	5AL043	003.995.4002	Clamp Kit
4.	99730	311.490.7340	Clamp

Dinex no: 5AP002
OE no: 000.140.4678,
000.140.5078, 000.140.5778,
000.140.5478, 000.140.7178,
000.140.8178
Type: Pump for AdBlue®



Dinex no: 5AT000
OE no: 000.140.5339,
000.140.5439, 000.140.3939
Type: Injector for AdBlue®



Dinex diesel particulate filter kit

Dinex no: 5AI003 / New

Dinex no: 5AI003-RX / Reconditioned



OE no: 001.490.7592
Type: Diesel Particle Filter

Dinex no: 5AL004
OE no: 001.995.4544
Type: Clamp

Dinex no: 35822
OE no: 680.995.0202
Type: Clamp

Dinex no: 5AL005
OE no: 000.491.1380
Type: Gasket

Kit number: 5AL029



EURO 6

4x2



Vehicle engine

OM936 H

7,7 ltr. / 6 cyl.

175KW / 238HP

200KW / 272HP

220KW / 299HP

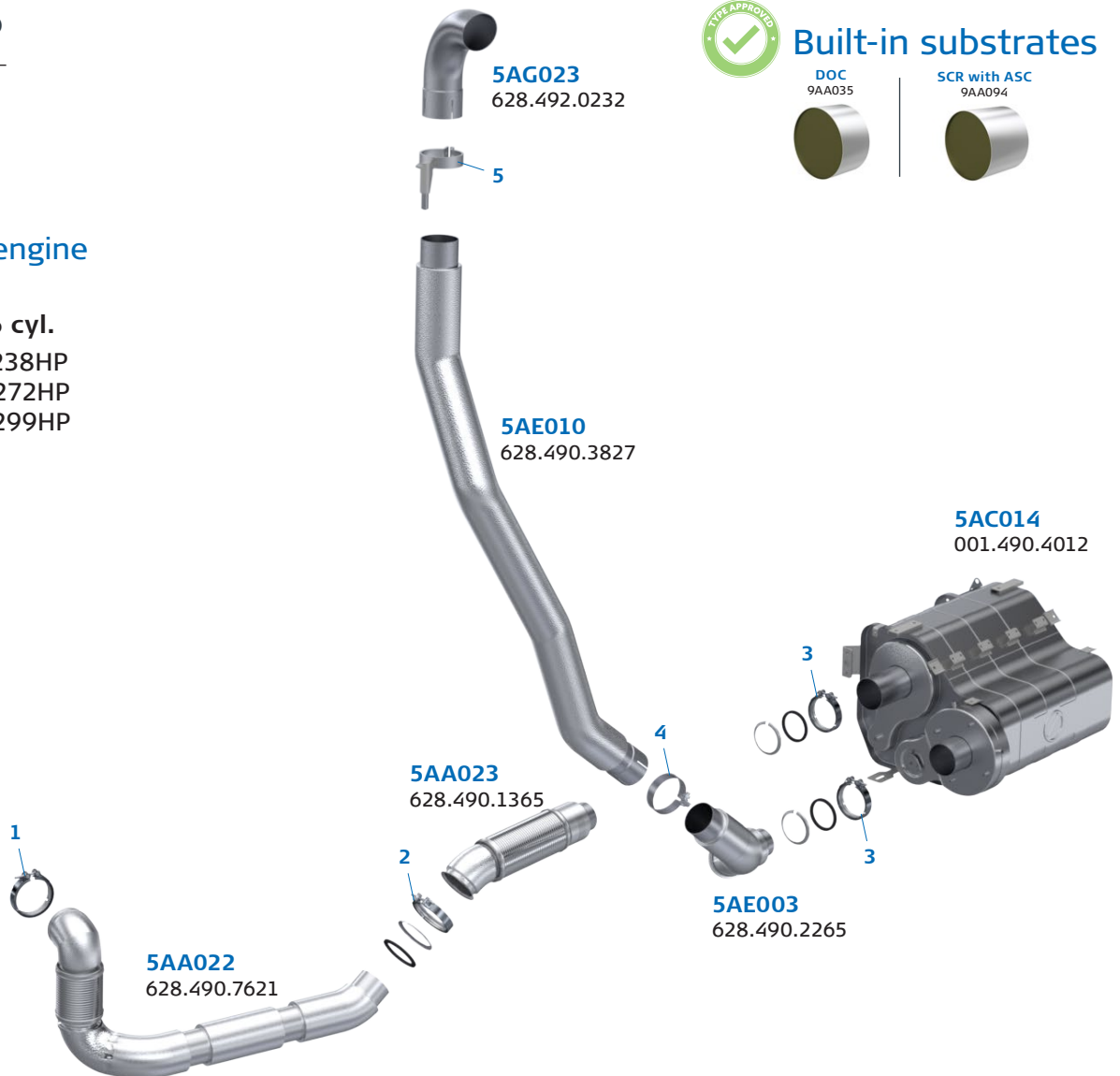

Dinex diesel particulate filter kit

Dinex no: 5AI012 / New

Dinex no: 5AI012-RX / Reconditioned

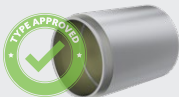

OE no: 002.490.4292
Type: Diesel Particle Filter



Dinex no: 5AL004
OE no: 001.995.4544
Type: Clamp



Dinex no: 35822
OE no: 680.995.0202
Type: Clamp



Dinex no: 5AL005
OE no: 000.491.1380
Type: Gasket

Kit number: 5AL029

Mechatronics



Dinex no: 51073
OE no: 008.542.4618
Dinex no: 51074
OE no: 009.542.8918
Dinex no: 51075
OE no: 009.542.8418
Type: Temperature Sensor



Dinex no: 51027
OE no: 009.153.0128
Dinex no: 51035
OE no: 008.153.9928
Type: NOx Sensor



Dinex no: 51050
OE no: 01.0153.0028
Dinex no: 51051
OE no: 01.0153.0228
Type: Pressure Sensor

Accessories

No.	Dinex no	OE no	Type
1.	5AL011	001.995.0702	Clamp
2.	5AL013	002.995.7102	Clamp Kit
3.	5AL012	003.995.0902	Clamp Kit
4.	99710	628.995.3502	Gasket
5.	5AL061	311.490.5340	Clamp



Dinex no: 5AP002
OE no: 000.140.4678, 000.140.5078, 000.140.5778, 000.140.5478, 000.140.7178, 000.140.8178
Type: Pump for AdBlue®



Dinex no: 5AT000
OE no: 000.140.5339, 000.140.5439, 000.140.3939
Type: Injector for AdBlue®

EURO 6

4x2



Vehicle engine

OM 936 H / 7,7 ltr. / 6 cyl.

175KW / 238HP

200KW / 272HP

220KW / 299HP

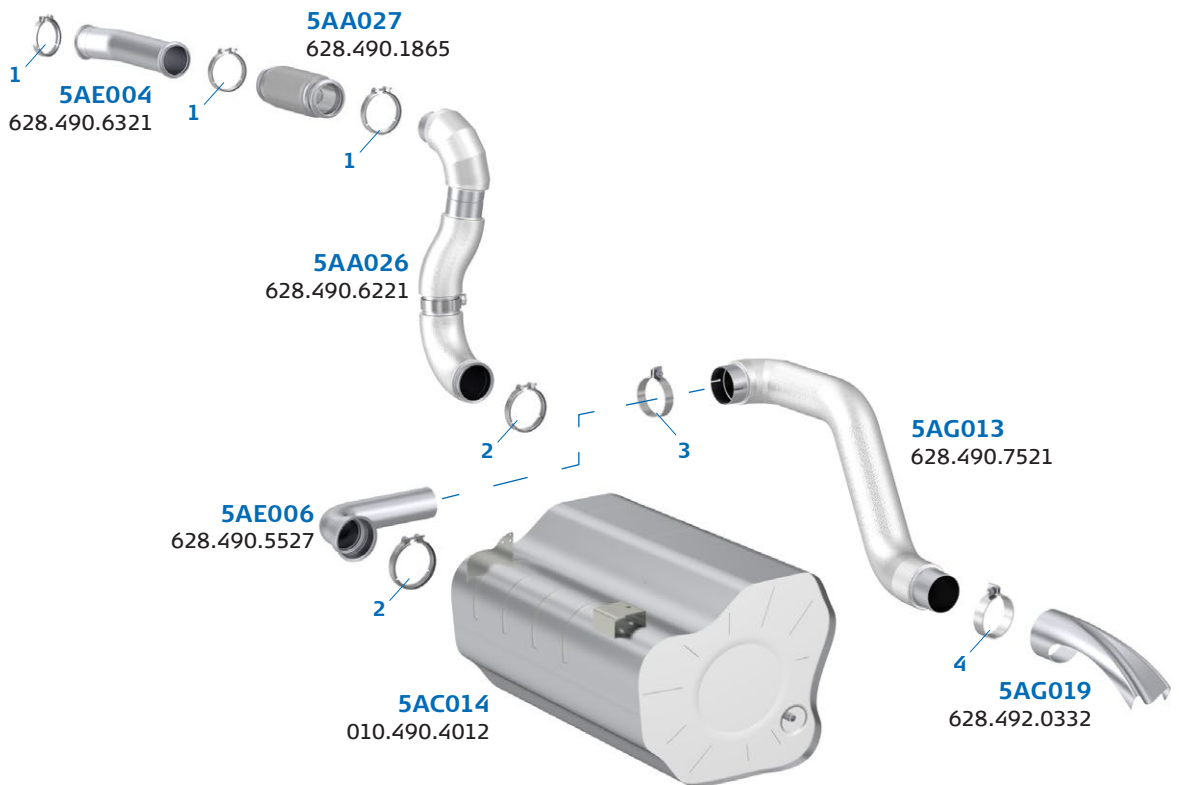

Built-in substrates

DOC
9AA035



SCR with ASC
9AA094

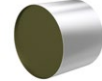

Dinex diesel particulate filter kit

Dinex no: 5AI003 / New

Dinex no: 5AI003-RX / Reconditioned



OE no: 001.490.7592
Type: Diesel Particle Filter



Dinex no: 5AL004
OE no: 001.995.4544
Type: Clamp



Dinex no: 35822
OE no: 680.995.0202
Type: Clamp



Dinex no: 5AL005
OE no: 000.491.1380
Type: Gasket

Kit number: 5AL029

Mechatronics



Dinex no: 51073
OE no: 008.542.4618
Dinex no: 51074
OE no: 009.542.8918
Dinex no: 51075
OE no: 009.542.8418
Dinex no: 51076
OE no: 009.542.8818
Type: Temperature Sensor



Dinex no: 51035
OE no: 008.153.9928,
010.153.9428
Dinex no: 51027
OE no: 009.153.0128,
010.153.9628
Type: NOx Sensor



Dinex no: 51051
OE no: 010.153.0228
Type: Pressure Sensor

Accessories

No.	Dinex no	OE no	Type
1.	5AL011	001.995.0702	Clamp
2.	5AL012	003.995.0902	Clamp
3.	5AL056	628.995.1902	Clamp
4.	5AL057	628.995.3502	Clamp



Dinex no: 5AP002
OE no: 000.140.4678,
000.140.5078, 000.140.5778,
000.140.5478, 000.140.7178,
000.140.8178
Type: Pump for AdBlue®



Dinex no: 5AT000
OE no: 000.140.5339,
000.140.5439, 000.140.3939
Type: Injector for AdBlue®

EURO 6

4x2



Vehicle engine

OM936 H

7,7 ltr. / 6 cyl.

175KW / 238HP

200KW / 272HP

220KW / 299HP



Built-in substrates

DOC
9AA035



SCR with ASC
9AA094

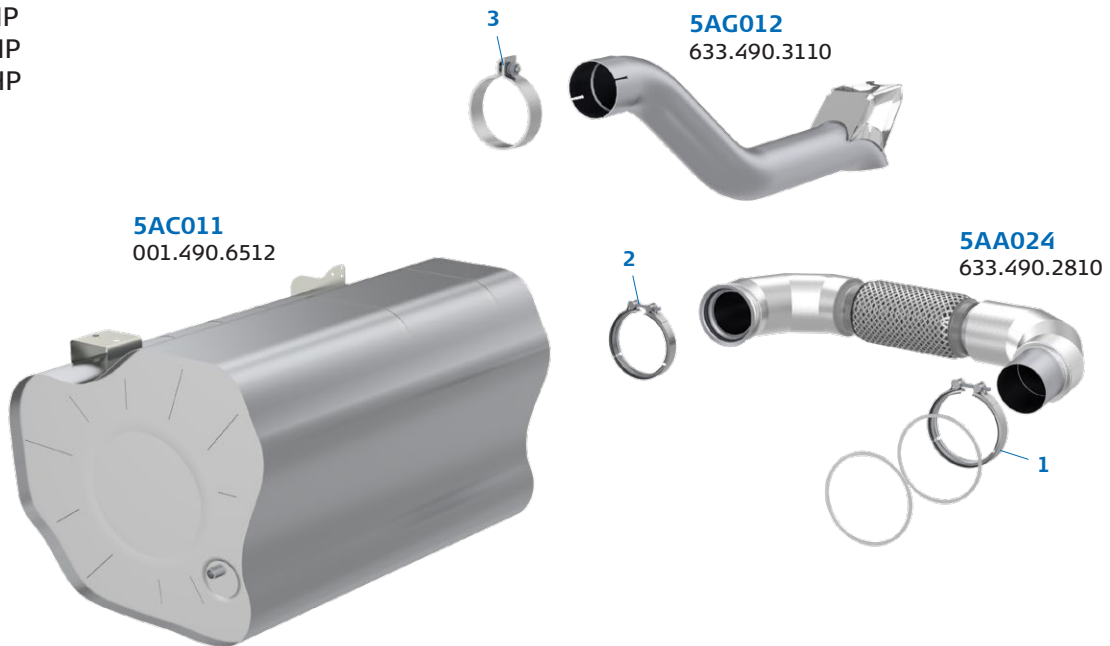
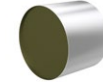

Dinex diesel particulate filter kit

Dinex no: 5AI004 / New

Dinex no: 5AI004-RX / Reconditioned



OE no: 001.490.2992
Type: Diesel Particle Filter
Technology: HP-SiC



Dinex no: 5AL004
OE no: 001.995.5744, 001.995.4444
Type: Clamp



Dinex no: 35822
OE no: 680.995.0202
Type: Clamp



Dinex no: 5AL005
OE no: 000.491.1380
Type: Gasket

Kit number: 5AL029

Mechatronics



Dinex no: 51083
OE no: 010.542.1618
Dinex no: 51077
OE no: 010.542.1718
Dinex no: 51078
OE no: 010.542.1818
Dinex no: 51079
OE no: 010.542.1918
Type: Temperature Sensor



Dinex no: 51035
OE no: 008.153.9928
Dinex no: 51027
OE no: 009.153.0128
Type: NOx Sensor



Dinex no: 51050
OE no: 01.0153.0028
Dinex no: 51051
OE no: 01.0153.0228
Type: Pressure Sensor

Accessories

No.	Dinex no	OE no	Type
1.	5AL012	003.995.0902	Clamp Kit
2.	5AL011	001.995.0702	Clamp
3.	5AL035	949.492.0040	Clamp



Dinex no: 5AP002
OE no: 000.140.4678, 000.140.5078, 000.140.5778, 000.140.5478, 000.140.7178, 000.140.8178
Type: Pump for AdBlue®



Dinex no: 5AT000
OE no: 000.140.5339, 000.140.5439, 000.140.3939
Type: Injector for AdBlue®

EURO 6

4x2



Vehicle engine

OM470 LA
10,7 ltr. / 6 cyl.
 240KW / 326HP
 265KW / 360HP



Built-in substrates

DOC
9AA035



SCR with ASC
9AA094

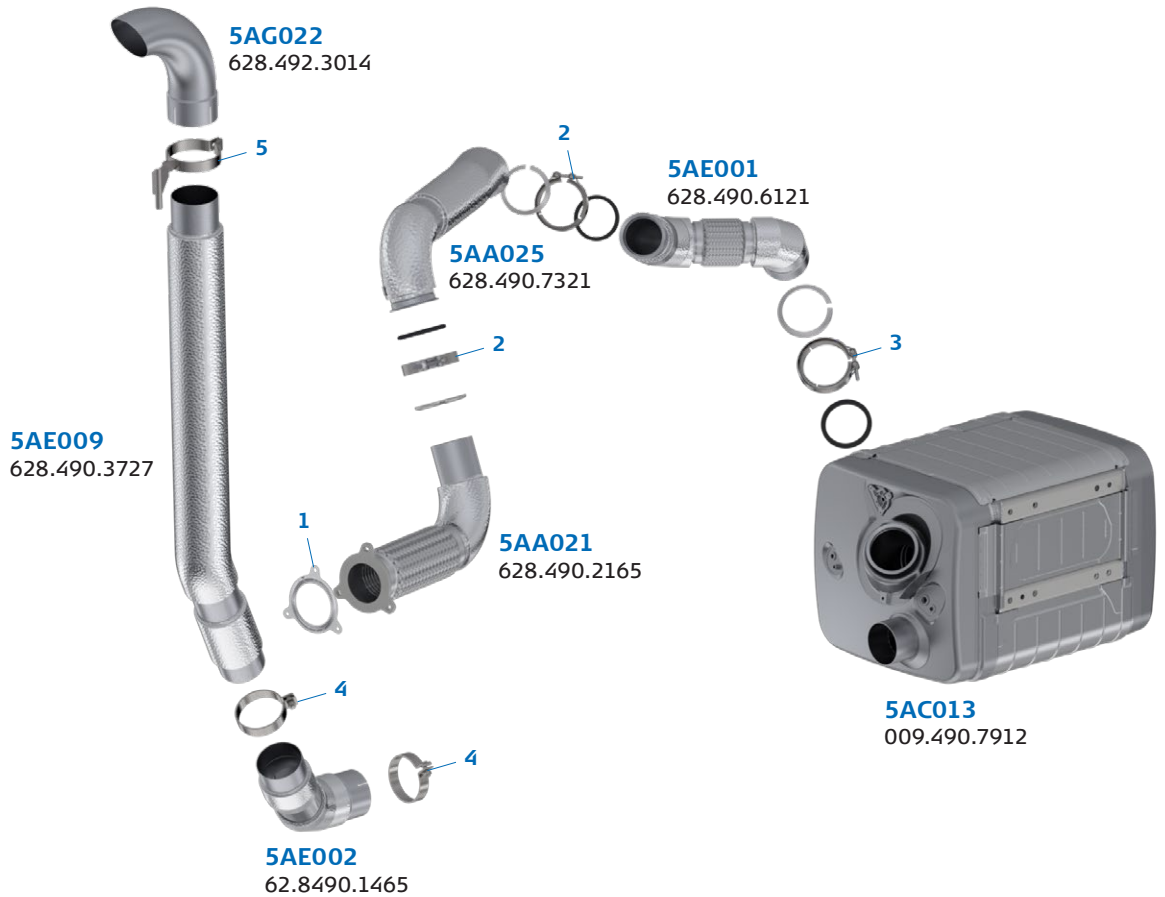
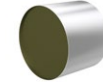

Dinex diesel particulate filter kit

Dinex no: 5AI005 / New
 Dinex no: 5AI005-RX / Reconditioned



OE no: 001.490.7092,
001.490.8392, 001.490.5292
Type: Diesel Particle Filter
Technology: HP-SiC



Kit number: 5AL031

Dinex no: 5AL004
OE no: 001.995.5744,
001.995.4444
Type: Clamp

Dinex no: 5AL003
OE no: 000.995.3933,
000.995.1833
Type: Clamp

Dinex no: 50902
OE no: 000.491.1580
Type: Gasket

Mechatronics



Dinex no: 51088
OE no: 009.542.8518
Dinex no: 51081
OE no: 008.542.1318
Dinex no: 51082
OE no: 008.542.1418
Type: Temperature Sensor



Dinex no: 51027
OE no: 009.153.0128
Dinex no: 51035
OE no: 008.153.9928
Type: NOx Sensor



Dinex no: 51050
OE no: 01.0153.0028
Dinex no: 51054
OE no: 01.0153.0128
Type: Pressure Sensor

Accessories

No.	Dinex no	OE no	Type
1.	5AL037	470.142.0480	Gasket
2.	5AL013	003.995.4402	Clamp Kit
3.	5AL011	001.995.0702	Clamp Kit
4.	99730	942.492.0140	Clamp
5.	5AL054	311.490.8540	Clamp



Dinex no: 5AP006
OE no: 000.140.5578
Type: Pump for AdBlue®



Dinex no: 5AT000
OE no: 000.140.5339,
000.140.5439, 000.140.3939
Type: Injector for AdBlue®

EURO 6

4x2 - 6x2



Vehicle engine

OM470 LA
10,7 ltr. / 6 cyl.
 240KW / 326HP
 265KW / 360HP



Built-in substrates

DOC
9AA035



SCR with ASC
9AA094

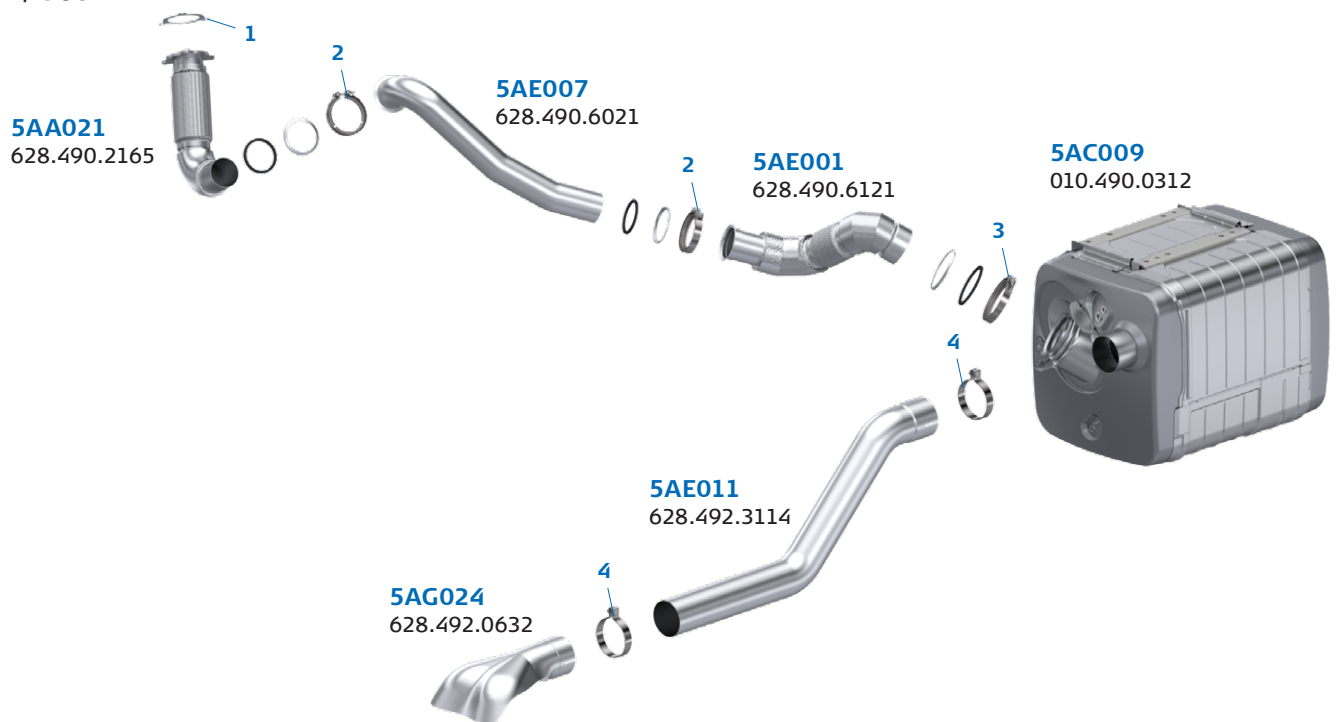
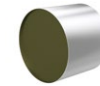

Dinex diesel particulate filter kit

Dinex no: 5AI007 / New
 Dinex no: 5AI007-RX / Reconditioned



OE no: 002.490.3892
 Type: Diesel Particle Filter
 Technology: HP-SiC



Dinex no: 50902
 OE no: 000.491.1580
 Type: Clamp

Dinex no: 5AL055
 OE no: 000.995.1833
 Type: Clamp

Dinex no: 5AL021
 OE no: 000.491.1280
 Type: Gasket

Mechatronics



Dinex no: 51088
 OE no: 009.542.8518
 Dinex no: 51081
 OE no: 008.542.1318
 Dinex no: 51082
 OE no: 008.542.1418
 Type: Temperature Sensor



Dinex no: 51027
 OE no: 009.153.0128
 Dinex no: 51035
 OE no: 008.153.9928
 Type: NOx Sensor



Dinex no: 51050
 OE no: 01.0153.0028
 Dinex no: 51054
 OE no: 01.0153.0128
 Type: Pressure Sensor

Accessories

No.	Dinex no	OE no	Type
1.	5AL037	470.142.0480	Gasket
2.	5AL013	002.995.7102	Clamp Kit
3.	5AL028	003.995.0702	Clamp Kit
4.	99730	311.490.7340	Clamp



Dinex no: 5AP002
 OE no: 000.140.4678,
 000.140.5078, 000.140.5778,
 000.140.5478, 000.140.7178,
 000.140.8178
 Type: Pump for AdBlue®



Dinex no: 5AT000
 OE no: 000.140.5339,
 000.140.5439, 000.140.3939
 Type: Injector for AdBlue®

EURO 6

4x2



Vehicle engine

OM936 H

7,7 ltr. / 6 cyl.

175KW / 238HP

200KW / 272HP

220KW / 299HP



Built-in substrates

DOC
9AA035



SCR with ASC
9AA094

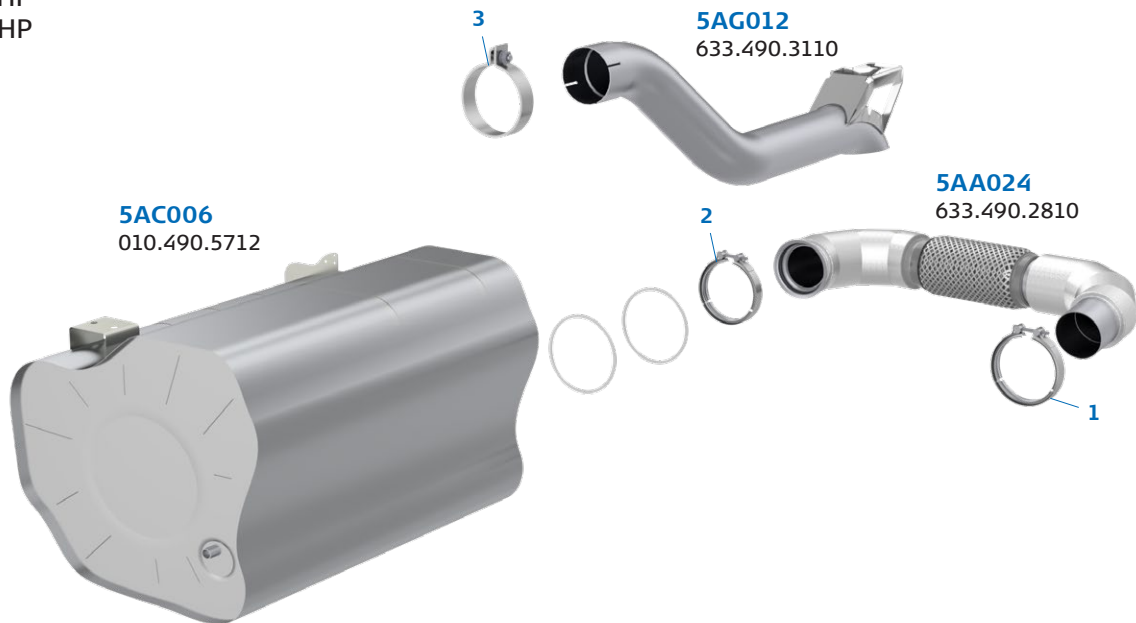
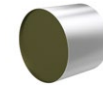

5AC006
010.490.5712



5AG012
633.490.3110



5AA024
633.490.2810

2



1

Dinex diesel particulate filter kit

Dinex no: 5AI011 / New

Dinex no: 5AI011-RX / Reconditioned



OE no: 002.490.4192
Type: Diesel Particulate Filter
Technology: HP-SiC



Dinex no: 5AL004
OE no: 001.995.5744,
001.995.4444
Type: Clamp



Dinex no: 35822
OE no: 680.995.0202
Type: Clamp



Dinex no: 5AL005
OE no: 000.491.1380
Type: Gasket

Kit number: 5AL029

Mechatronics



Dinex no: 51083
OE no: 010.542.1618
Dinex no: 51077
OE no: 010.542.1718
Dinex no: 51078
OE no: 010.542.1818
Dinex no: 51079
OE no: 010.542.1918
Type: Temperature Sensor



Dinex no: 51028
OE no: 010.153.1528
Dinex no: 51029
OE no: 010.153.1728
Type: NOx Sensor



Dinex no: 51050
OE no: 01.0153.0028
Dinex no: 51051
OE no: 01.0153.0228
Type: Pressure Sensor

Accessories

No.	Dinex no	OE no	Type
1.	5AL012	003.995.0902	Clamp
2.	5AL011	001.995.0702	Clamp Kit
3.	5AL035	949.492.0040	Clamp



Dinex no: 5AP002
OE no: 000.140.4678,
000.140.5078, 000.140.5778,
000.140.5478, 000.140.7178,
000.140.8178
Type: Pump for AdBlue®



Dinex no: 5AT000
OE no: 000.140.5339,
000.140.5439, 000.140.3939
Type: Injector for AdBlue®

EURO 6

4x2



Vehicle engine

OM470 LA
10,7 ltr. / 6 cyl.
240KW / 326HP
265KW / 360HP



Built-in substrates

DOC
9AA035



SCR with ASC
9AA094

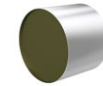

1

5AA020
629.490.3510



5AA024
633.490.2810

5AC007
001.490.0412



3

5AG007
629.490.0427



Dinex diesel particulate filter kit

Dinex no: 5AI007 / New
 Dinex no: 5AI007-RX / Reconditioned



OE no: 002.490.3892
Type: Diesel Particulate Filter
Technology: HP-SiC



Dinex no: 50902
OE no: 000.491.1580
Type: Clamp



Dinex no: 5AL055
OE no: 000.995.1833
Type: Clamp



Dinex no: 5AL021
OE no: 000.491.1280
Type: Gasket

Kit number: 5AL062

Mechatronics



Dinex no: 51080
OE no: 008.542.1018
Dinex no: 51081
OE no: 008.542.1318
Dinex no: 51082
OE no: 008.542.1418
Type: Temperature Sensor



Dinex no: 51027
OE no: 009.153.0128
Dinex no: 51035
OE no: 008.153.9928
Type: NOx Sensor



Dinex no: 51050
OE no: 01.0153.0028
Dinex no: 51054
OE no: 01.0153.0128
Type: Pressure Sensor

Accessories

No.	Dinex no	OE no	Type
1.	5AL036	471.142.0580	Gasket
2.	5AL028	003.995.0702	Clamp Kit
3.	99730	942.492.0140	Clamp



Dinex no: 5AP002
OE no: 000.140.4678, 000.140.5078, 000.140.5778, 000.140.5478, 000.140.7178, 000.140.8178
Type: Pump for AdBlue®



Dinex no: 5AT000
OE no: 000.140.5339, 000.140.5439, 000.140.3939
Type: Injector for AdBlue®

SCANIA



Content **SCANIA**

The only ATS unit with both – easily replaceable DPF and DOC without any cutting or welding for the most longevity. The flex pipes are made from high quality stainless steel, wound and tested to the highest detail contributing to the benefits of replaceable substrates. Direct replacement for OE unit. Dinex also offers all exhaust pipes and other parts related to the exhaust system for Scania buses.

Type/Model

N (NUD 6.7L).....	46
N.....	47
N (NUB)	48
N (NUD 9.3L).....	49
K.....	50

EURO 6

4x2 - 6x2



Vehicle engine

D7
6,7 ltr. / 6 cyl.
205KW / 280HP



Built-in substrates

DOC
9AA045



SCR with ASC
9AA100

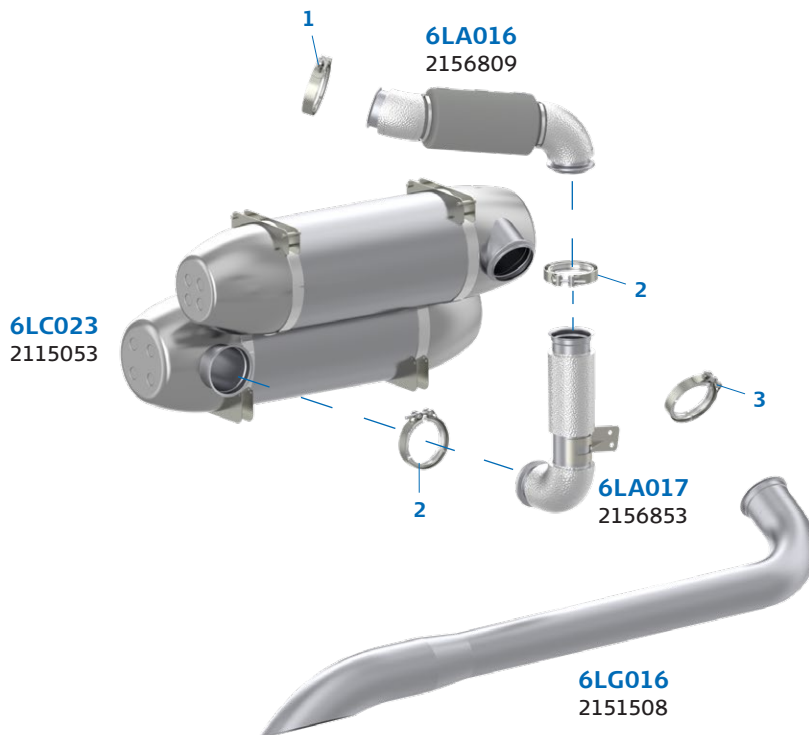

Dinex diesel particulate filter kit

Dinex no: 2AI003 / New
Dinex no: 2AI003-RX / Reconditioned



OE no: 2274555
Type: Diesel Particle Filter
Technology: HP-SiC

Kit number: 2AI022
OE no: 1976845



Dinex no: 6LL011
Type: Clamp

Dinex no: 6LL012
Type: Gasket

Mechatronics



Dinex no: 67045
OE no: 2277896
Dinex no: 67046
OE no: 2277780
Type: Temperature Sensor



Dinex no: 67035
OE no: 2462239
Dinex no: 67037
OE no: 2382082
Type: NOx Sensor



Dinex no: 67051
OE no: 2277783
Type: Pressure Sensor

Accessories

No.	Dinex no	OE no	Type
1.	6LL022	2197729	Clamp
2.	6LL013	2263307	Clamp
3.	6LL027	2092177	Clamp



Dinex no: 6LP002
OE no: 2660146
Type: Pump for AdBlue®



Dinex no: 6LT017
OE no: 2307569
Type: Injector for AdBlue®

EURO 6

4x2



Vehicle engine

D7
6,7 ltr. / 6 cyl.
205KW / 280HP



Built-in substrates

DOC
9AA045



SCR with ASC
9AA100

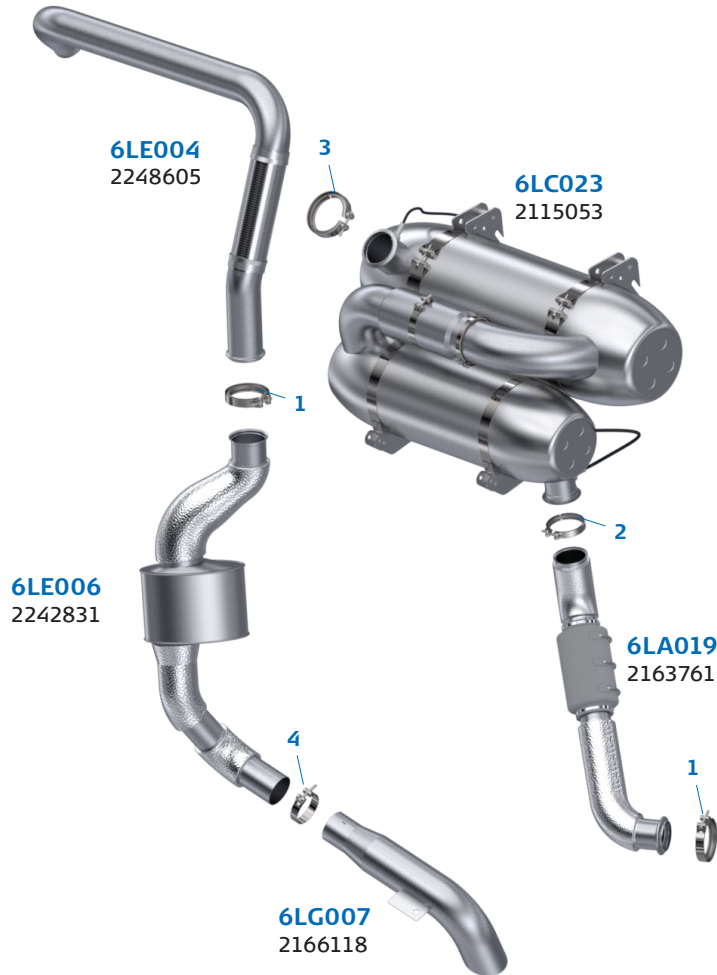

Dinex diesel particulate filter kit

Dinex no: 2AI003 / New
Dinex no: 2AI003-RX / Reconditioned



OE no: 2274555
Type: Diesel Particle Filter
Technology: HP-SiC

Kit number: 2AI022
OE no: 1976845



Dinex no: 6LL011
Type: Clamp

Dinex no: 6LL012
Type: Gasket

Mechatronics



Dinex no: 67045
OE no: 2277896
Dinex no: 67046
OE no: 2277780
Type: Temperature Sensor



Dinex no: 67035
OE no: 2462239
Dinex no: 67037
OE no: 2382082
Type: NOx Sensor



Dinex no: 67051
OE no: 2277783
Type: Pressure Sensor

Accessories

No.	Dinex no	OE no	Type
1.	6LL013	2263307	Clamp
2.	6LL022	2197729	Clamp
3.	6LL027	2092177	Clamp
4.	6LL028	2134613	Clamp



Dinex no: 6LP002
OE no: 2660146
Type: Pump for AdBlue®



Dinex no: 6LT017
OE no: 2307569
Type: Injector for AdBlue®

EURO 6

4x2



Vehicle engine

D7
6,7 ltr. / 6 cyl.
205KW / 280HP



Built-in substrates

DOC
9AA045



SCR with ASC
9AA100

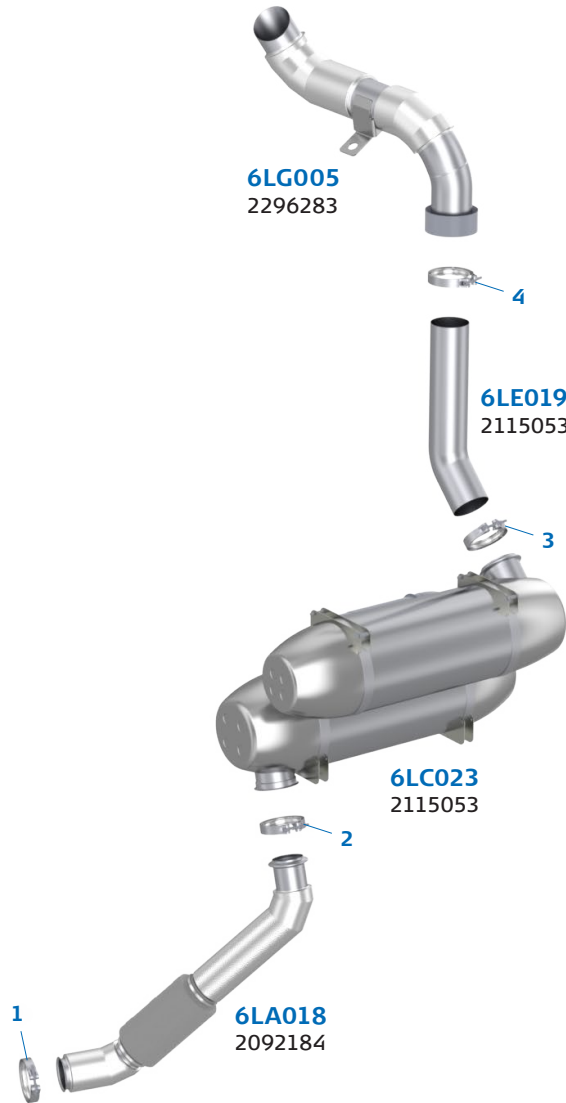

Dinex diesel particulate filter kit

Dinex no: 2AI003 / New
Dinex no: 2AI003-RX / Reconditioned



OE no: 2274555
Type: Diesel Particle Filter
Technology: HP-SiC

Kit number: 2AI022
OE no: 1976845



Dinex no: 6LL011
Type: Clamp

Dinex no: 6LL012
Type: Gasket

Mechatronics



Dinex no: 67045
OE no: 2277896
Dinex no: 67046
OE no: 2277780
Type: Temperature Sensor



Dinex no: 67035
OE no: 2462239
Dinex no: 67037
OE no: 2382082
Type: NOx Sensor



Dinex no: 67051
OE no: 2277783
Type: Pressure Sensor

Accessories

No.	Dinex no	OE no	Type
1.	6LL022	2197729	Clamp
2.	6LL013	2263307	Clamp
3.	6LL027	2092177	Clamp
4.	99921	1779825	Clamp



Dinex no: 6LP002
OE no: 2660146
Type: Pump for AdBlue®



Dinex no: 6LT017
OE no: 2307569
Type: Injector for AdBlue®

EURO 6

4x2 - 6x2



Vehicle engine

DC9
9,3 ltr. / 5 cyl.
 183KW / 250HP
 205KW / 280HP
 235KW / 320HP
 264KW / 360HP



DOC
6LI006



SCR with ASC
9AA096



Built-in substrates

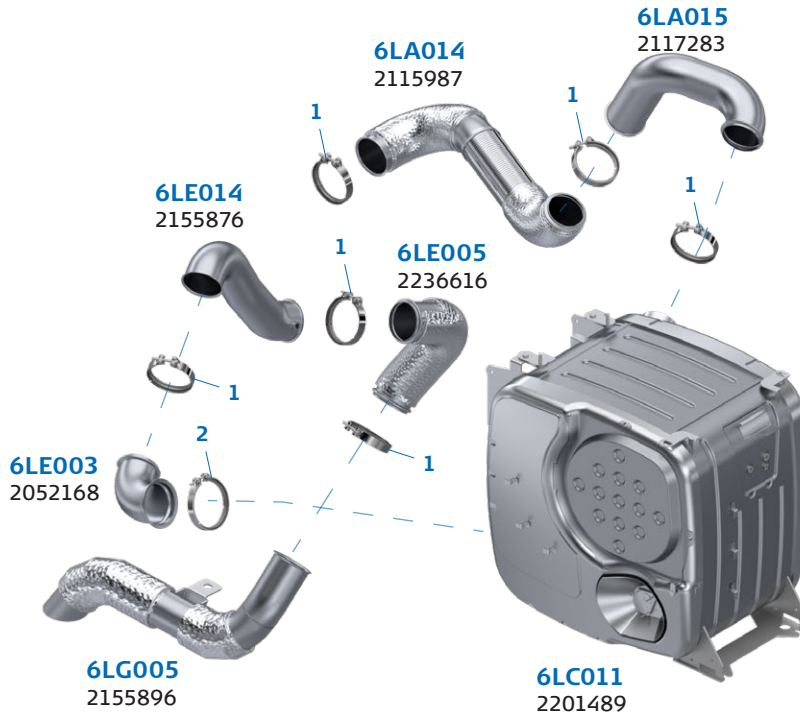

Dinex diesel particulate filter kit

Dinex no: 6LI000 / New
 Dinex no: 6LI000-RX / Reconditioned



OE no: 2269640
Type: Diesel Particle Filter



Dinex no: 6LL008
OE no: 2168586, 2588429
Type: Gasket



Dinex no: 6LL006
OE no: 2097659
Type: Gasket



Dinex no: 6LL005
OE no: 2097660
Type: Clamp

Kit number: 6LL016

Mechatronics



Dinex no: 67045
OE no: 2277896
Dinex no: 67046
OE no: 2277780
Type: Temperature Sensor



Dinex no: 67035
OE no: 2462239
Dinex no: 67037
OE no: 2382082
Type: NOx Sensor



Dinex no: 67051
OE no: 2277783
Type: Pressure Sensor

Accessories

No.	Dinex no	OE no	Type
1.	68835	1863831	Clamp
2.	68858	1863832	Clamp



Dinex no: 6LP001
OE no: 2057543
Type: Pump for AdBlue®



Dinex no: 6LT000
OE no: 2238325
Type: Injector for AdBlue®

EURO 6

4x2



Vehicle engine

DC9
9,3 ltr. / 5 cyl.
 183KW / 250HP
 205KW / 280HP
 235KW / 320HP
 264KW / 360HP



DOC
6LI006



SCR with ASC
9AA096



Built-in substrates



Dinex diesel particulate filter kit

Dinex no: 6LI000 / New
 Dinex no: 6LI000-RX / Reconditioned



OE no: 2269640
Type: Diesel Particle Filter



Dinex no: 6LL008
OE no: 2168586, 2588429
Type: Gasket



Dinex no: 6LL006
OE no: 2097659
Type: Gasket



Dinex no: 6LL005
OE no: 2097660
Type: Clamp

Kit number: 6LL016

Mechatronics



Dinex no: 67042
OE no: 2604683
Type: Temperature Sensor



Dinex no: 67031
OE no: 2294290
Dinex no: 67032
OE no: 2294291
Type: NOx Sensor



Dinex no: 67052
OE no: 2357734
Type: Pressure Sensor

Accessories

No.	Dinex no	OE no	Type
1.	68835	1863831	Clamp
2.	6LL024	2199870	Gasket
3.	6LL023	2198109	Gasket
4.	68858	1863832	Clamp



Dinex no: 6LP001
OE no: 2057543
Type: Pump for AdBlue®



Dinex no: 6LT000
OE no: 2238325
Type: Injector for AdBlue®

Content **VDL**

ATS solution comprising cordierite or high porosity silicon carbide DPF with optimal PGM loading for soot-free emissions and cordierite DOC and SCR for the highest catalytic efficiency. Coupled with Dinex below and insulation technologies, perfect for OE replacement. ATS silencer consists of two sections with DOC and DPF and a section with SCR. Dinex also offers all exhaust pipes and other parts related to exhaust systems for VDL buses.

Type/Model

FUTURA 20 FHD2 - TYPES 106/131/135 52

FUTURA 20 FHD2 - TYPES 106/122/129 53

EURO 6

4x2



Vehicle engine

MX11
10,8 ltr. / 6 cyl.
240KW / 330HP
270KW / 370HP



Built-in substrates

DOC
9AA026

SCR with ASC
9AA087

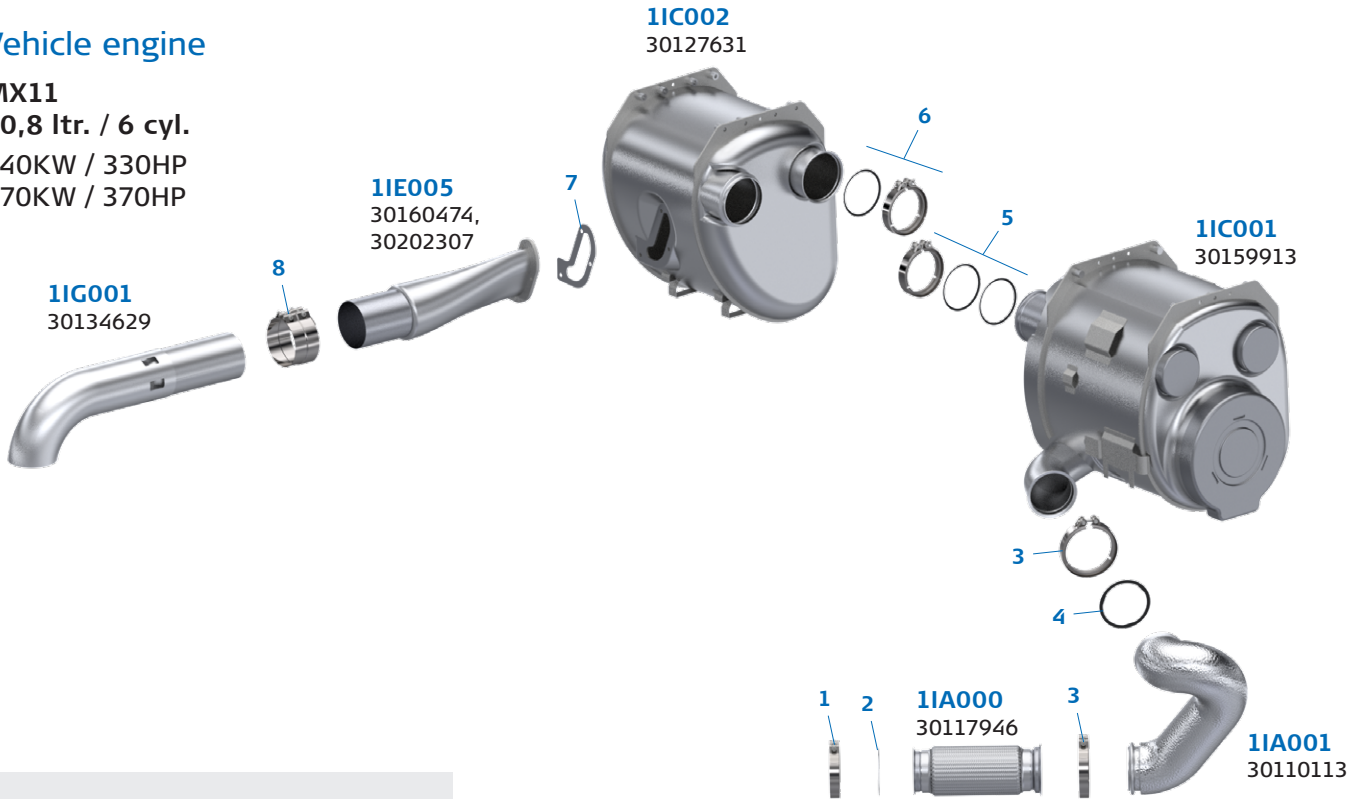
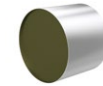

Dinex diesel particulate filter kit

Dinex no: 2AI000 / New
 Dinex no: 2AI000-RX / Reconditioned



OE no: 41891485
Type: Diesel Particle Filter



Dinex no: 2AL010
Type: Thin gasket



Dinex no: 2AL009
Type: Clamp



Dinex no: 2AL008
Type: Gasket



Dinex no: 2AL012
Type: Knitwire



Dinex no: 2AL011
Type: Rope

Kit number: 2AL038
 OE no: 1927181

Mechatronics



Dinex no: 17041
OE no: 30127633
Dinex no: 17042
OE no: 30127639
Type: Temperature Sensor



Dinex no: 17034
OE no: 30167580
Type: NOx Sensor



Dinex no: 17050
OE no: 30127640
Type: Pressure Sensor



Dinex no: 2AP002
OE no: 1819797, 2871880,
 0444042137
Type: Pump for AdBlue®



Dinex no: 2AT002
OE no: 1819798, 1975291
Type: Injector for AdBlue®

Accessories

No.	Dinex no	OE no	Type
1.	1IL000	30131282, 30161355	Clamp
2.	1IL001	30131284	Gasket
3.	1IL002	30131283, 30161356	Clamp
4.	1IL003	30131285	Gasket
5.	1IL006	41927175	Clamp Kit
6.	1IL007	41927176	Clamp Kit
7.	1IL008	30125673	Gasket
8.	1IL005	30134630	Strap

EURO 6

4x2



Vehicle engine

MX11
10,8 ltr. / 6 cyl.
 240KW / 330HP
 270KW / 370HP



Built-in substrates

DOC
9AA119

SCR with ASC
9AA120

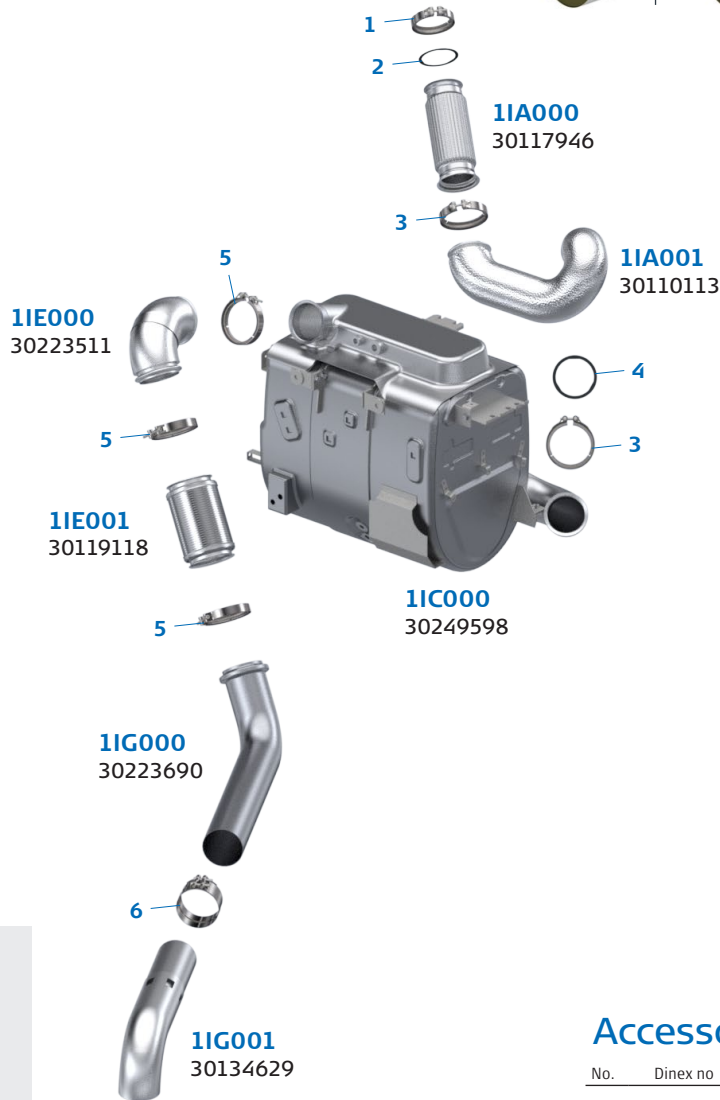
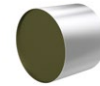

Dinex diesel particulate filter kit

Dinex no: 2AI005 / New
 Dinex no: 2AI005-RX / Reconditioned



OE no: 31009912
Type: Diesel Particle Filter



Dinex no: 2AL043
Type: Clamp



Dinex no: 2AL044
Type: Gasket



Dinex no: 2AL045
Type: Knitwire



Dinex no: 2AL046
Type: Rope

Kit number: 2AL042
 OE no: 2192099

x 2

Accessories

No.	Dinex no	OE no	Type
1.	1IL000	30131282, 30161355	Clamp
2.	1IL001	30131284	Gasket
3.	1IL002	30131283, 30161356	Clamp
4.	1IL003	30131285	Gasket
5.	1IL004	20270578	Clamp
6.	1IL005	30134630	Strap

Mechatronics



Dinex no: 17040
OE no: 31009910
Type: Temperature Sensor



Dinex no: 17034
OE no: 30167580
Type: NOx Sensor



Dinex no: 17050
OE no: 30127640
Type: Pressure Sensor



Dinex no: 2AP002
OE no: 1819797, 2871880,
0444042137
Type: Pump for AdBlue®



Dinex no: 2AT002
OE no: 1819798, 1975291
Type: Injector for AdBlue®



Content **VOLVO**

Well-designed OneBox solution with the same PGM loading as OE to secure complete system functionality. This system uses cordierite DOC, DPF, and SCR. DPF is easily replaceable and more affordable. Combined with the advanced DOC, SCR, and high-quality insulation technologies, the emission levels are on par with that of OE. Dinex also offers all exhaust pipes and other parts related to the exhaust system for Volvo buses.

Type/Model

B11R EURO 5.....	55
B13R EURO 5	56
B5TL(3) EURO 6.....	57
B5LH(3) EURO 6	58
B5LH(3) / B5LHC(3) EURO 6	59
B8R(3) EURO 6	60
B11R(3) EURO 6.....	61
B11R(3) EURO 6.....	62

EURO 5

4x2 - 6x2



Vehicle engine

D11C

10,8 ltr. / 6 cyl.

240KW / 330HP

270KW / 370HP

305KW / 410HP

355KW / 450HP

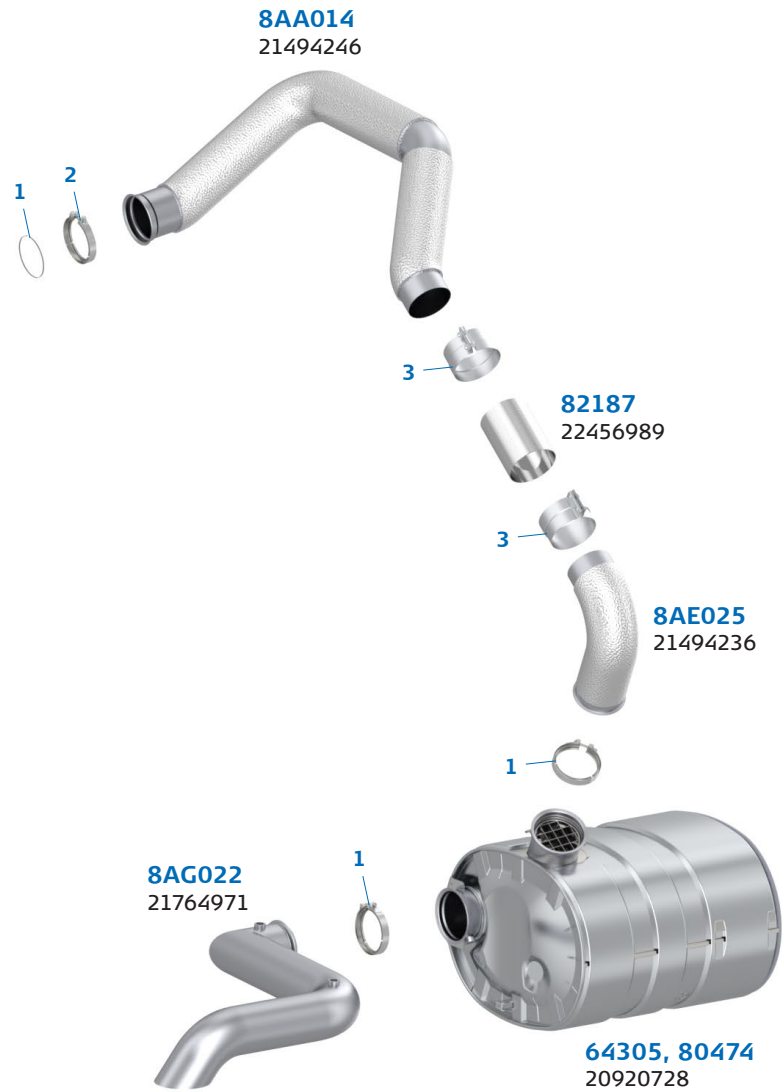

Mechatronics



Dinex no: 81043
OE no: 22827993
Type: Temperature Sensor



Dinex no: 8AP002
OE no: 21200982, 21210636, 21350672, 21582902
Type: Pump for AdBlue®



Dinex no: 81030
OE no: 22827993
Dinex no: 81031
OE no: 21567742
Type: NOx Sensor



Dinex no: 8AT026
OE no: 21738132
Type: Injector for AdBlue®

Accessories

No.	Dinex no	OE no	Type
1.	80921	1629499	Clamp
2.	80920	1638168	Gasket
3.	80871	21408723	Clamp

EURO 5

4x2 - 6x2



Vehicle engine

D13C
12,8 ltr. / 6 cyl.
 309KW / 420HP
 338KW / 460HP
 368KW / 500HP

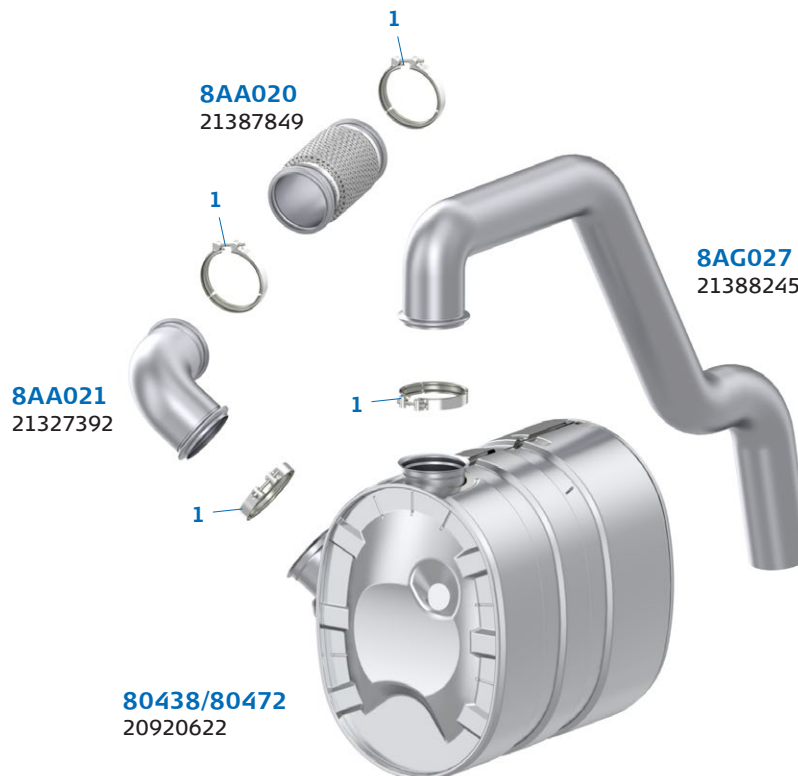

Accessories

No.	Dinex no	OE no	Type
1.	80921	1629499	Clamp

Mechatronics



Dinex no: 81033
OE no: 20889280
Type: Temperature Sensor



Dinex no: 8AP002
OE no: 21200982, 21210636, 21350672, 21582902
Type: Pump for AdBlue®



Dinex no: 81030
OE no: 22827993
Type: NOx Sensor



Dinex no: 8AT026
OE no: 21738132
Type: Injector for AdBlue®

x2

EURO 6

4x2



Vehicle engine

D5K
5,1 ltr. / 4 cyl.
177KW / 240HP



Built-in substrates

DOC
9AA057



SCR with ASC
9AA098

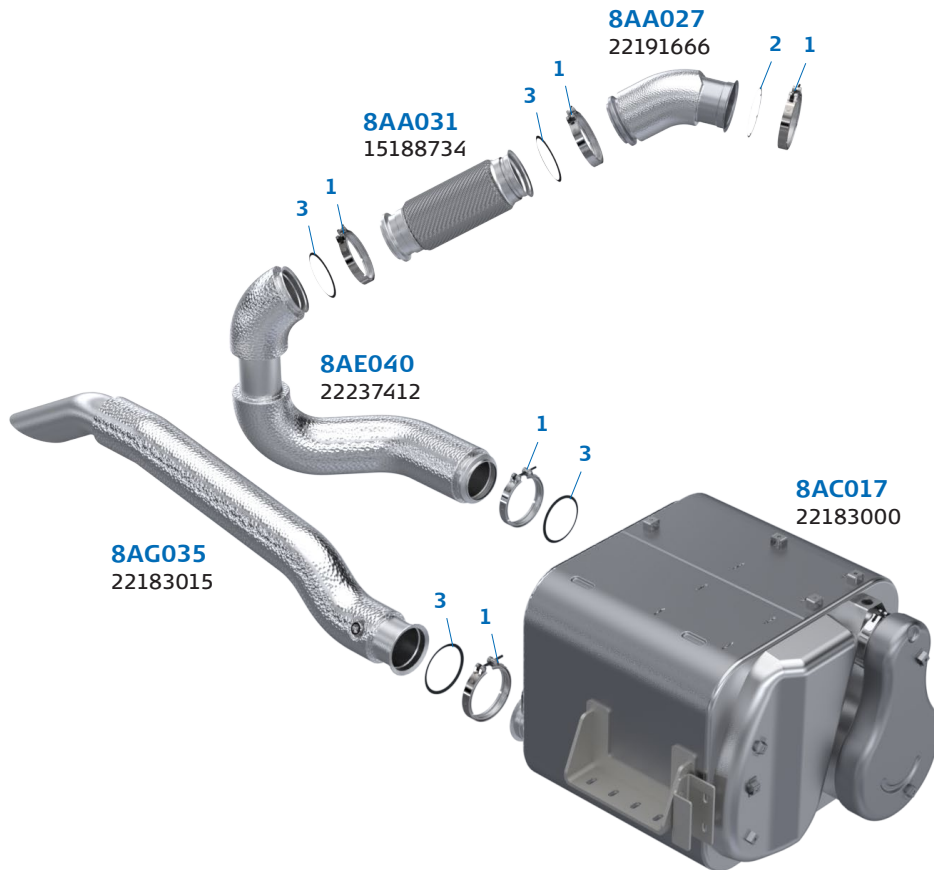
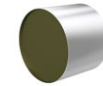

Dinex diesel particulate filter kit

Dinex no: 8AI001 / New
Dinex no: 8AI001-RX / Reconditioned



OE no: 21794709
Type: Diesel Particle Filter



Dinex no: 8AL014
OE no: 21664904
Type: Clamp



Dinex no: 8AL013
OE no: 21664918
Type: Gasket

Kit number: 8AL030
x 2



Dinex no: 8AL015
OE no: 21664906
Type: Clamp

Mechatronics



Dinex no: 81043
OE no: 21412472
Dinex no: 81045
OE no: 21225020
Dinex no: 81046
OE no: 21164414
Dinex no: 81048
OE no: 21126692
Type: Temperature Sensor



Dinex no: 81030
OE no: 21984358
Dinex no: 81034
OE no: 21558128
Type: NOx Sensor



Dinex no: 8CL004
OE no: 21403962
Type: Pressure Sensor

Accessories

No.	Dinex no	OE no	Type
1.	80910	21472836	Clamp
2.	8AL033	23121323	Gasket
3.	8AL001	21758870	Gasket



Dinex no: 8AP003
OE no: 21687873, 22900358, 23387863, 7421687873
Type: Pump for AdBlue®



Dinex no: 8AT008
OE no: 21781227
Type: Injector for AdBlue®

EURO 6

4x2



Vehicle engine

D5K
5,1 ltr. / 4 cyl.
177KW / 240HP

D8K
7,7 ltr. / 6 cyl.
206KW / 280HP

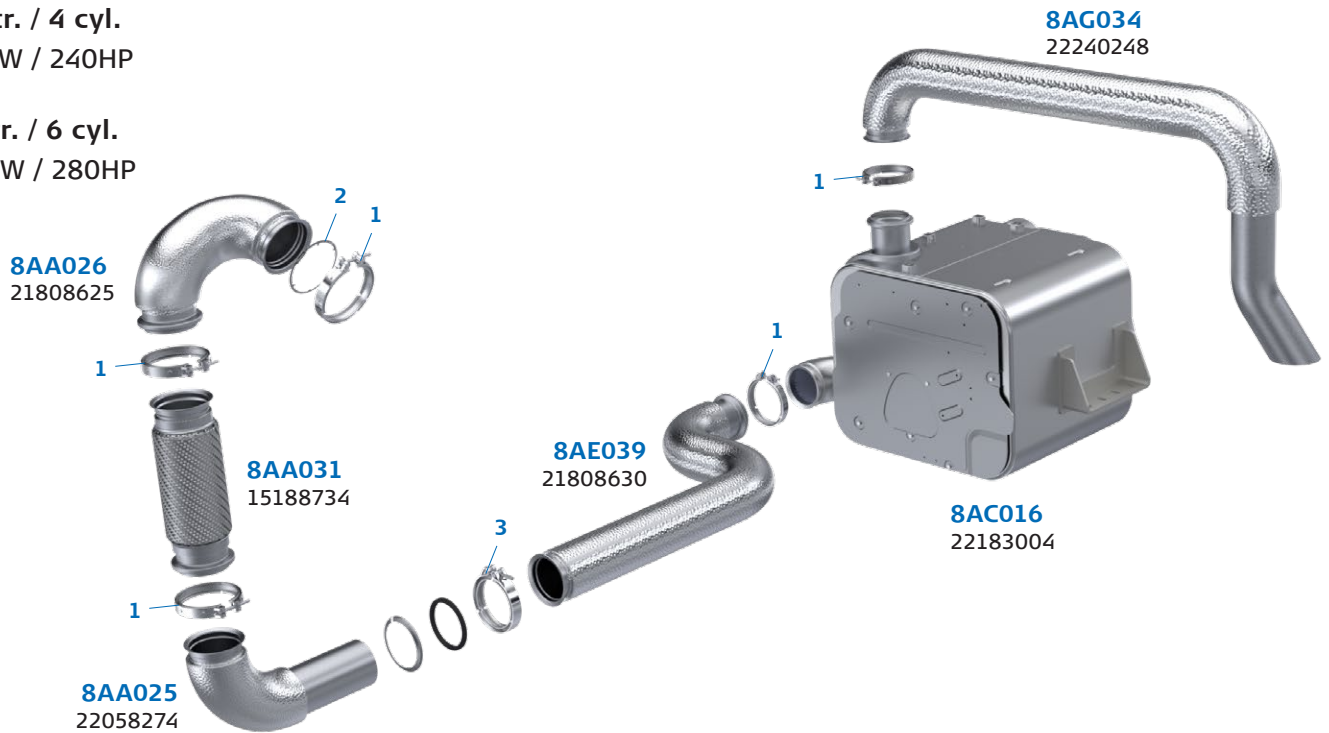

Built-in substrates

DOC
9AA057



SCR with ASC
9AA098



Dinex diesel particulate filter kit

Dinex no: 8AI001 / New
Dinex no: 8AI001-RX / Reconditioned



OE no: 21794709
Type: Diesel Particle Filter



Dinex no: 8AL014
OE no: 21664904
Type: Clamp

Dinex no: 8AL013
OE no: 21664918
Type: Gasket

Dinex no: 8AL015
OE no: 21664906
Type: Clamp

Mechatronics



Dinex no: 81043
OE no: 21412472
Dinex no: 81045
OE no: 21225020
Dinex no: 81046
OE no: 21164414
Dinex no: 81048
OE no: 21126692
Type: Temperature Sensor



Dinex no: 81030
OE no: 21984358
Dinex no: 81034
OE no: 21558128
Type: NOx Sensor



Dinex no: 8CL004
OE no: 21403962
Type: Pressure Sensor

Accessories

No.	Dinex no	OE no	Type
1.	80910	21472836	Clamp
2.	8AL033	23121323	Gasket
3.	8AL046	22056565	Clamp



Dinex no: 8AP003
OE no: 21687873, 22900358, 23387863, 7421687873
Type: Pump for AdBlue®



Dinex no: 8AT008
OE no: 21781227
Type: Injector for AdBlue®

EURO 6

4x2



Vehicle engine

D5K
5,1 ltr. / 4 cyl.

177KW / 240HP

D8K
7,7 ltr. / 6 cyl.

206KW / 280HP

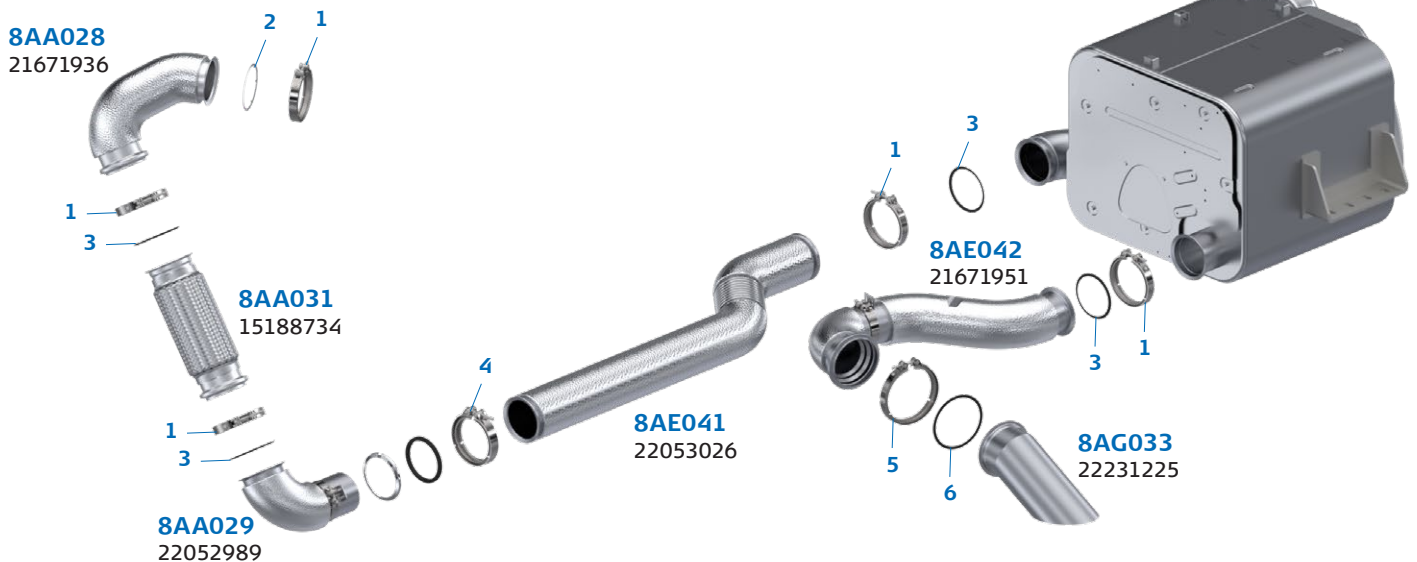

Built-in substrates

DOC
9AA057



SCR with ASC
9AA098

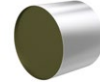

Dinex diesel particulate filter kit

Dinex no: 8AI001 / New

Dinex no: 8AI001-RX / Reconditioned



OE no: 21794709
Type: Diesel Particle Filter



Dinex no: 8AL014
OE no: 21664904
Type: Clamp



Dinex no: 8AL013
OE no: 21664918
Type: Gasket



Dinex no: 8AL015
OE no: 21664906
Type: Clamp

Kit number: 8AL030

Mechatronics



Dinex no: 81043
OE no: 21412472
Dinex no: 81045
OE no: 21225020
Dinex no: 81046
OE no: 21164414
Dinex no: 81048
OE no: 21126692
Type: Temperature Sensor



Dinex no: 81030
OE no: 21984358
Dinex no: 81034
OE no: 21558128
Type: NOx Sensor



Dinex no: 8CL004
OE no: 21403962
Type: Pressure Sensor

Accessories

No.	Dinex no	OE no	Type
1.	80910	21472836	Clamp
2.	8AL033	23121323	Gasket
3.	8AL001	21758870	Gasket
4.	8AL046	22056565	Clamp
5.	80921	21719872	Clamp
6.	78843	21758872	Gasket



Dinex no: 8AP003
OE no: 21687873, 22900358, 23387863, 7421687873
Type: Pump for AdBlue®



Dinex no: 8AT008
OE no: 21781227
Type: Injector for AdBlue®

EURO 6

4x2



Vehicle engine

D8K

7,7 ltr. / 6 cyl.

206KW / 280HP

235KW / 320HP

258KW / 350HP



Built-in substrates

DOC
9AA057



SCR with ASC
9AA098

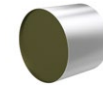

8AA024
21696314



8AA031
15188734



8AA022
22026471



8AE038
22026537



8AE037
21986055



8AC016
22183004

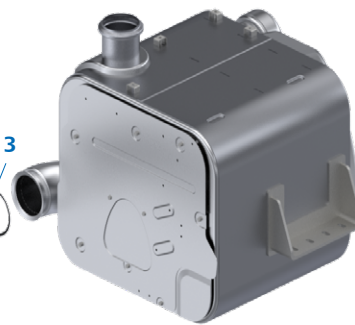

8AG033
22231225



Dinex diesel particulate filter kit

Dinex no: 8AI001 / New

Dinex no: 8AI001-RX / Reconditioned



OE no: 21794709
Type: Diesel Particle Filter



Dinex no: 8AL014
OE no: 21664904
Type: Clamp



Dinex no: 8AL013
OE no: 21664918
Type: Gasket



Dinex no: 8AL015
OE no: 21664906
Type: Clamp

Kit number: 8AL030
x 2

Mechatronics



Dinex no: 81043
OE no: 21412472
Dinex no: 81045
OE no: 21225020
Dinex no: 81046
OE no: 21164414
Dinex no: 81048
OE no: 21126692
Type: Temperature Sensor



Dinex no: 81030
OE no: 21984358
Dinex no: 81034
OE no: 21558128
Type: NOx Sensor



Dinex no: 8CL004
OE no: 21403962
Type: Pressure Sensor

Accessories

No.	Dinex no	OE no	Type
1.	80910	21472836	Clamp
2.	8AL033	23121323	Gasket
3.	8AL001	21758870	Gasket
4.	8AL046	22056565	Clamp
5.	80921	21719872	Clamp
6.	78843	21758872	Gasket



Dinex no: 8AP003
OE no: 21687873, 22900358, 23387863, 7421687873
Type: Pump for AdBlue®



Dinex no: 8AT008
OE no: 21781227
Type: Injector for AdBlue®

EURO 6

4x2 - 6x2



Vehicle engine

D11K
10,8 ltr. / 6 cyl.

280KW / 380HP
320KW / 430HP
343KW / 460HP



Built-in substrates

DOC
9AA024

SCR with ASC
9AA100

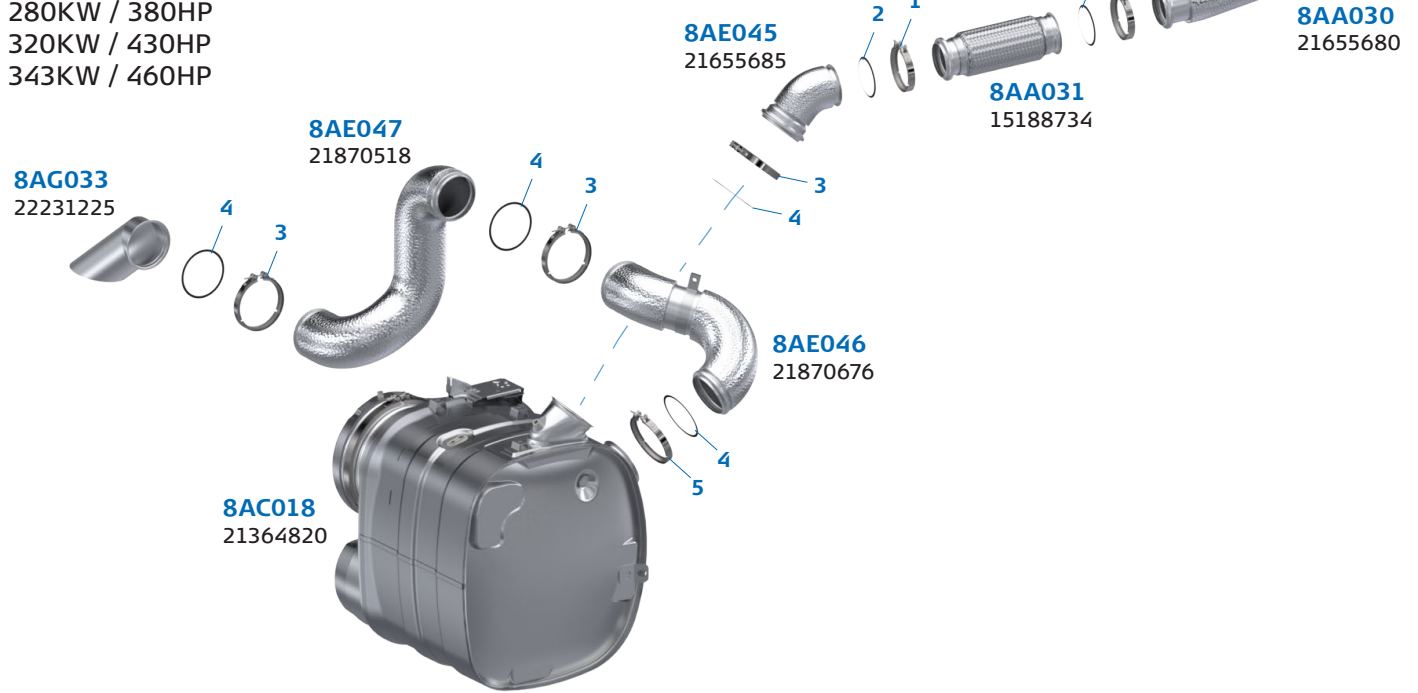
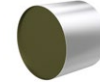

8AG033
22231225

8AE047
21870518

8AE045
21655685

8AA031
15188734

8AA030
21655680

8AE046
21870676

8AC018
21364820

Dinex diesel particulate filter kit

Dinex no: 8AI002 / New
Dinex no: 8AI002-RX / Reconditioned



OE no: 21716414
Type: Diesel Particle Filter



Dinex no: 8AL006
OE no: 21445539
Type: Clamp



Dinex no: 8AL005
OE no: 21570880
Type: Gasket



Dinex no: 8AL016
OE no: 21445536
Type: Clamp

Kit number: 8AL031
x 2

Mechatronics



Dinex no: 81045
OE no: 21225020
Dinex no: 81046
OE no: 21164414
Dinex no: 81048
OE no: 21126692
Type: Temperature Sensor



Dinex no: 81030
OE no: 21984358
Dinex no: 81034
OE no: 21558128
Type: NOx Sensor



Dinex no: 8CL004
OE no: 21403962
Type: Pressure Sensor

Accessories

No.	Dinex no	OE no	Type
1.	80910	21472836	Clamp
2.	8AL001	21758870	Gasket
3.	80921	21719872	Clamp
4.	78843	21758872	Gasket
5.	8AL065	21986404	Clamp



Dinex no: 8AP003
OE no: 21687873, 22900358, 23387863, 7421687873
Type: Pump for AdBlue®



Dinex no: 8AT008
OE no: 21781227
Type: Injector for AdBlue®

EURO 6

4x2 - 6x2



Vehicle engine

D11K
10,8 ltr. / 6 cyl.
 280KW / 380HP
 320KW / 430HP
 343KW / 460HP



Built-in substrates

DOC
9AA024



SCR with ASC
9AA100

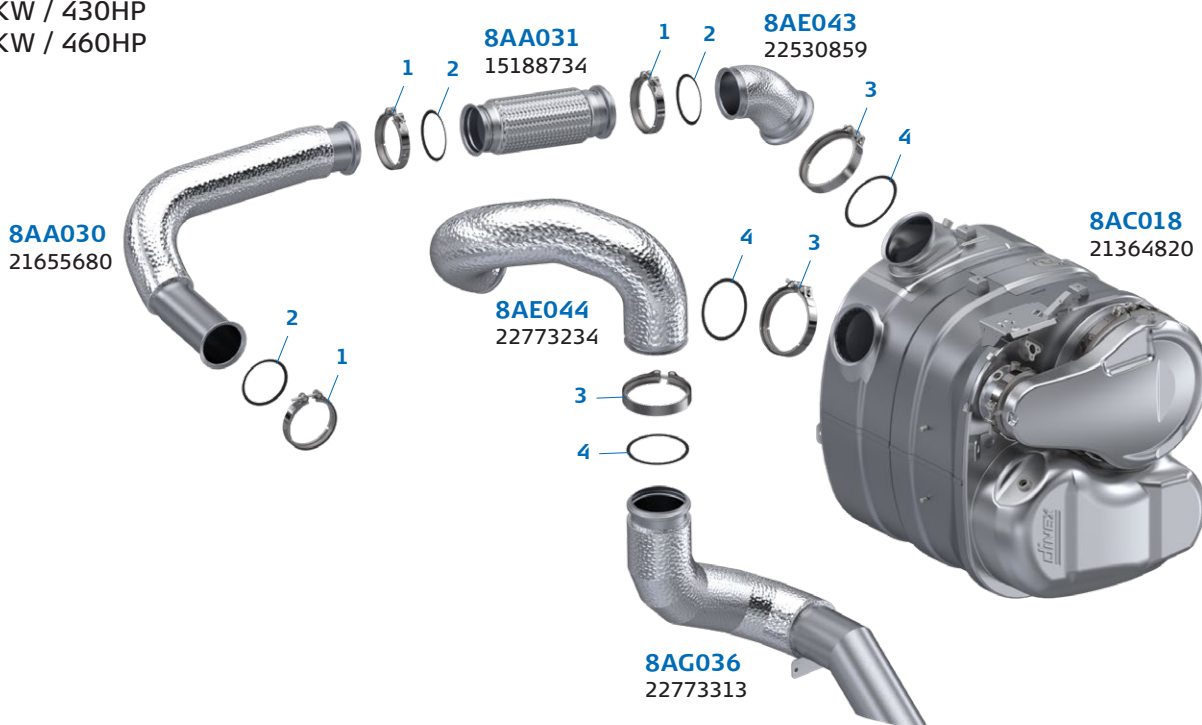
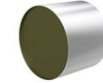

Dinex diesel particulate filter kit

Dinex no: 8AI002 / New
 Dinex no: 8AI002-RX / Reconditioned



OE no: 21716414
Type: Diesel Particle Filter



Dinex no: 8AL006
OE no: 21445539
Type: Clamp



Dinex no: 8AL005
OE no: 21570880
Type: Gasket



Dinex no: 8AL016
OE no: 21445536
Type: Clamp

Kit number: 8AL031
 x 2

Mechatronics



Dinex no: 81045
OE no: 21225020
Dinex no: 81046
OE no: 21164414
Dinex no: 81048
OE no: 21126692
Type: Temperature Sensor



Dinex no: 81030
OE no: 21984358
Dinex no: 81034
OE no: 21558128
Type: NOx Sensor



Dinex no: 8CL004
OE no: 21403962
Type: Pressure Sensor

Accessories

No.	Dinex no	OE no	Type
1.	80910	21472836	Clamp
2.	8AL001	21758870	Gasket
3.	8AL044	22568585	Clamp
4.	78843	21758872	Gasket



Dinex no: 8AP003
OE no: 21687873, 22900358, 23387863, 7421687873
Type: Pump for AdBlue®



Dinex no: 8AT008
OE no: 21781227
Type: Injector for AdBlue®

Time for DPF Service?

Don't get tempted by half-way solutions... it will cost you in the long run



2-step Cleaning vs. 3-step Reconditioning

A simple 2-step cleaning by a professional workshop removes most ash and soot, but the hardened remains will act like a glaze that reduces the ability to regenerate. This will cost you in terms of back pressure and engine performance, leading to higher fuel consumption and more downtime due to frequent cleaning.

Reconditioning is a third step in which chemical dissolvents are applied to restore the functionality of the catalytic coating. You will experience the same benefits of installing a new filter, but at a much lower price.

Dinex Recon-RX is a full-range service that enable to you to swap your existing filter with a quality-checked, type-approved reconditioned filter. You receive a cash-back credit for your old filter, and you will be back on the road in no time – with 2 years warranty!

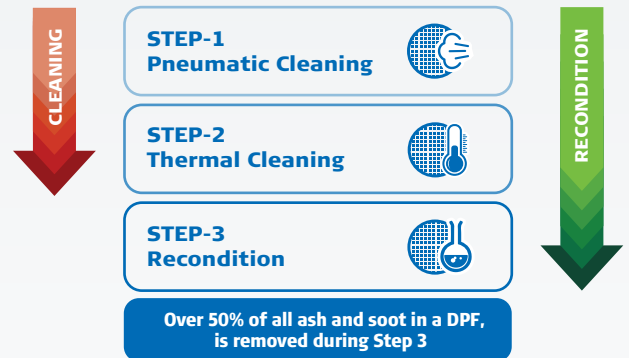

3 reasons why Reconditioning is better

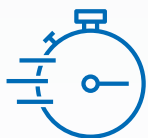

Reduce Downtime

Don't wait for cleaning: Get in, swap the DPF, and get out.



Extend Service Intervals

Fully restores the filters regenerating ability.



Improve Fuel Economy

Lower back pressure improves engine efficiency.



Hardened ash remaining in a filter after a 2-step cleaning process, resulting in more frequent cleaning, and higher fuel consumption.

Find out all the benefits by scanning the QR code with your smartphone.



Direct replacement parts



Dinex offers a wide range of direct replacement aftertreatment spare parts for Euro 6 silencers. In our portfolio we have type approved new and recon DPFs as well as some replaceable DOCs. All our DPFs come with all associated clamps and gaskets for easy installation and fitment.



Repair & Remanufacturing

With every new Euro emission standard, exhaust systems have transformed from a simple noise reduction device to a complicated aftertreatment system. Not only the involved technology, but the cost of the exhaust system has grown as well. Taking in account the high cost for a complete Euro 6 system, we are seeing a high interest of ATS repairs. In Euro 6 systems, DPF and in some cases even the DOC is designed to be replaceable. All these products you can get from Dinex. Aside from that, Dinex also offers all the other replacement parts when complimented with the support of professionals, you can refresh your ATS. This is a very complicated task, where you need to let the professionals do their job and entrust your ATS to specialized workshops.



All Dinex DPF, DOC and SCR are type approved and can be used only in specific applications they are designed for. They cannot be used in applications that are not the original goal of their design.



Dinex does not take the responsibility if you are affected by patent rights during silencer repair and selling under your own brand.



Dinex will support you by sharing knowledge through Dinex Academy



Dinex e-commerce platform

The Dinex e-commerce platform will increase efficiency and ease the procurement of goods for Dinex' aftermarket customers.

Dinex – Easy to do business with.



Visit the new Dinex webshop at dinex.net/webshop or scan QR code with your smartphone

- Custom made data transfer (API)
- Personalized webshop
- Claim handling
- Online return system
- Order / invoice history
- Available 24/7/365
- Time saving
- Warehouse status
- Gross-/net prices
- CSV import
- Responsxive on ALL devices
- Live events (product news, presentations, etc.)
- Detailed descriptions and pictures
- Installation videos
- 7 languages

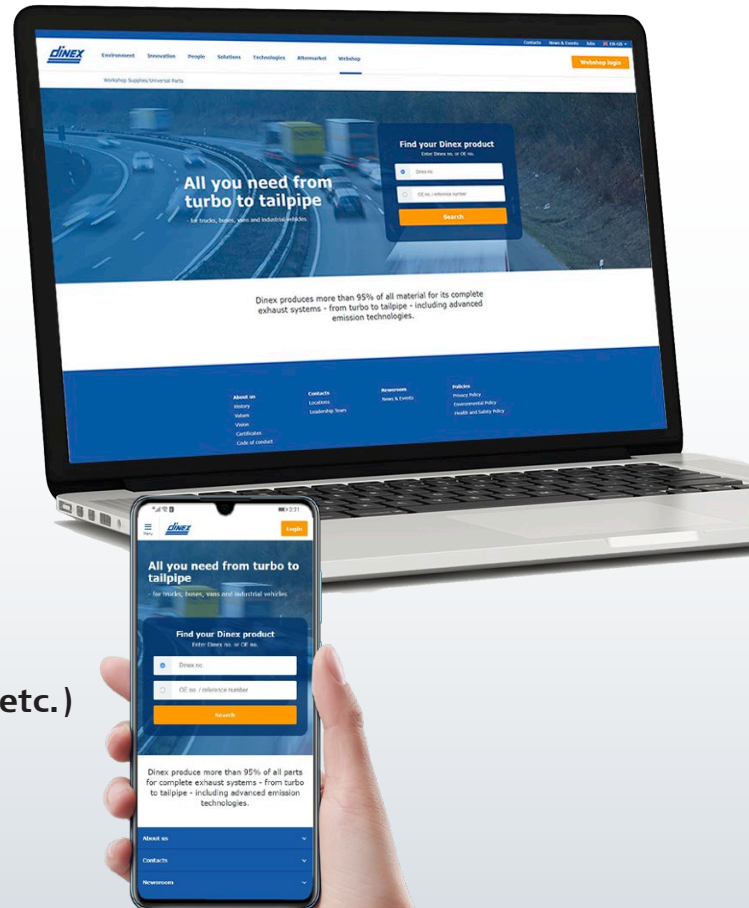

Please contact your local Dinex office to create an user account.

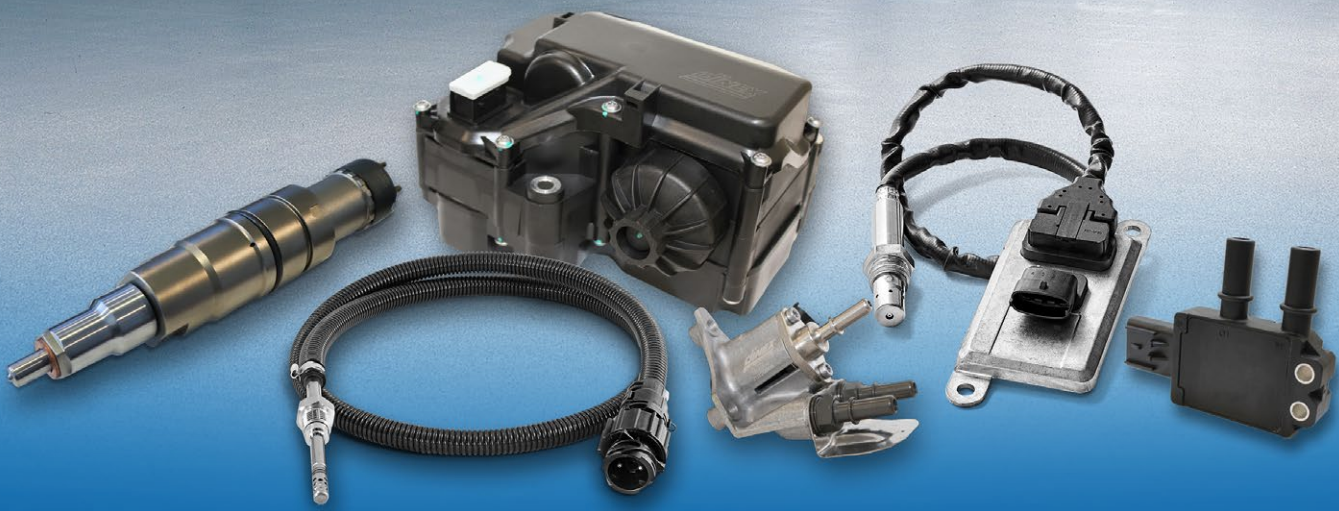

FULL MECHATRONIC RANGE

Your One-Stop-Shop of ALL spare parts from turbo to tailpipe, now also covers the most popular mechatronic spare parts for exhaust systems for your Euro 4-6 buses and trucks.

going the extra mile



Our Mechatronic parts are:

- Directly replaceable with OE
- Tested at Dinex Test Center
- Covering a wide range of vehicles
- High quality parts with warranty
- Stock items for fast delivery
- Easy to install



NO_x Sensors



Temperature Sensors



Pressure Sensors



Remanufactured Fuel Injectors



AdBlue® / DEF Dosers



AdBlue® / DEF Injectors



Dinex is ready to support you before, during and after the purchase. Get more technical knowledge about our full mechatronic program here.

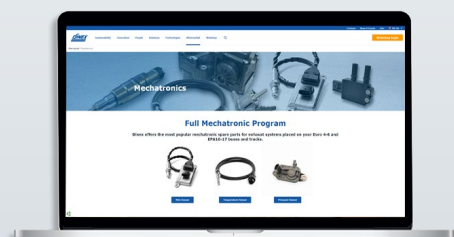

The aftermarket division of Dinex is a leading global manufacturer and distributor of innovative engineered exhaust and aftertreatment systems for the heavy duty truck industry with activities in Europe, North America and Russia.

With a program of more than 15.000 spare parts Dinex supply on a daily basis to over 6.000 distributors on a global scale. Our products are designed to the same level as OE or better. We take pride in our solutions with core technologies within modern aftertreatment systems for EURO 5 and 6 for Europe/Russia as well as EPA 07 and 10 for North America.

- | | | |
|----------------------------|--------------------------------------|--|
| ● Headquarter | ●● Dinex A/S, DK | ● Dinex Polska Sp. Z.o.o., PL |
| ● Tech. Center | ●● Dinex Latvia SIA, LV | ● Dinex SAS, FR |
| ● Factories | ●● Dinex Emission Inc., US | ● Dinex Italia S.R.L., IT |
| ● Warehouse & Distribution | ● Dinex RUS LLC, RU | ● Dinex Ibérica Sistemas de Esca, ES |
| | ● Dinex Egzoz ve Emisyon Tekn.sa, TR | ● Dinex Balkan D.O.O., RS |
| | ● Dinex Exhausts Ltd., GB | ● Dinex Deutschland GmbH (Kalbach), DE |



HQ Denmark, Middelfart



USA, Dublin, GA



Latvia, Jelgava



Dinex is ready to serve you

