

italmatic®

ACCESSORI PER RICOSTRUZIONE PNEUMATICI
TYRE RETREADING ACCESSORIES



italmatic®

GROUP

4 WORLD-LEADING COMPANIES

integrated into a single group to collaboratively create technological innovation in the sector.



The ITALMATIC GROUP is specialized in the design and manufacturing of high-tech complete plants for the retreading of tires up to 63", including shearography and robotic inspection, skiving, grooving. In the industrial segment, the group is also leader in the production of autoclaves, ovens, presses, moulds, extruders for rollers coating. In-house engineering and PLC software design are the key enablers of group success and internal verticalization of processes. The diversified offer includes accessories and consumables for retreaders and tyre shops, such as buffing blades, rasps, carbide tools, wheel balancing weights, and Italsensor TPMS pressure control systems for all type of vehicles.

INDUSTRIAL	CONSUMABLES	ENGINEERING & SERVICE
OTR RETREADING EQUIPMENTS	WHEEL BALANCING WEIGHT	ELECTRICAL AND PNEUMATIC SYSTEMS
TRUCK & CAR RETREADING EQUIPMENTS	CONSUMABLES FOR TIRE SHOPS	AUTOMATION
EQUIPMENTS FOR NEW TYRES	TPMS	RETROFIT & UPGRADE
AUTOCLAVES	CONSUMABLES FOR RETREADERS	SOFTWARE DEVELOPMENT
PRESSES FOR COMPOSITES	SOLID TYRES	SERVICE & MAINTENANCE
OVENS FOR COMPOSITES	CYLINDER COATING SERVICE	COMMISSIONING & START UP
EQUIPMENTS FOR CYLINDERS COATING		VULCANISATION PLANT SERVICES
AUTOMATED GUIDED VEHICLES – AGV		ROBOTICS ENGINEERING

Vertical INTEGRATION of engineering and production activities and synergies in processes maximize efficiency and added value.

100% MADE IN ITALY For maximum QUALITY control over production.

The KNOW-HOW and SPECIFIC SKILLS of our team generate the innovation that is the key to the success of the group.



The italmatic brand is synonymous of product and service quality.

italmatic®

Gamma completa di accessori e macchinari per la ricostruzione e riparazione pneumatici.

Complete range of accessories and machines for retreading & repairing of tyres.

Gamme complète d'accessoires et machines pour rechapage, réparation des pneus.

www.italmatic.group

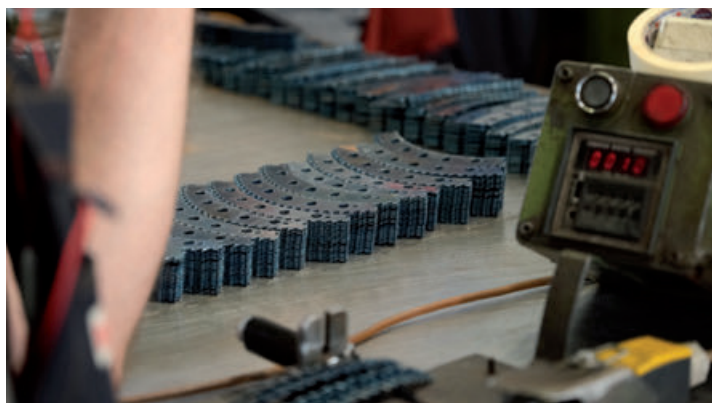
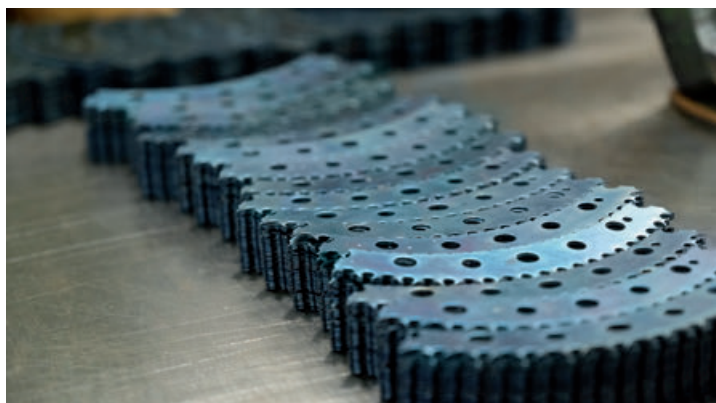

Il presente catalogo è di proprietà ITALMATIC s.r.l. - Ne è vietata la riproduzione, anche parziale, senza autorizzazione.

This catalogue is ITALMATIC s.r.l. property - Its even partial reproduction without authorization is forbidden.

Ce catalogue est propriété d'ITALMATIC s.r.l. - Sa reproduction même partielle sans autorisation est interdite.

Italmatic si riserva il diritto di modificare i prodotti in qualsiasi momento senza alcun preavviso. Immagini e colori sono da considerarsi puramente indicativi.

Italmatic reserve themselves the right to modify the products in any moment without any notice: Images and colours are only indicative.

Italmatic se réserve le droit de modifier les produits à n'importe quel moment sans aucun préavis. Images et couleurs doivent être considérés seulement indicatifs.

	LAME DI RASPATURA ITALMATIC <i>ITALMATIC BUFFING BLADES</i> <i>LAMES DE RÂPAGE ITALMATIC</i>	Pag. 4
	RASPE ITALMATIC, DISTANZIALI E PERNI <i>ITALMATIC RASPS, SPACERS AND PINS</i> <i>RÂPES ITALMATIC, INTERCALAIRES ET GOUJONS</i>	Pag. 6
	SCORTICATORI E SGORBIE ITALMATIC <i>ITALMATIC PEELING TEETH AND GOUGES</i> <i>ÉCORCHEURS ET GOUGES ITALMATIC</i>	Pag. 8
	MOLE ED UTENSILI CARBIDE ITALMATIC <i>ITALMATIC CARBIDE WHEELS AND TOOLS</i> <i>MEULES ET OUTILS CARBIDE ITALMATIC</i>	Pag. 10
	FRESE CARBIDE <i>CARBIDE CUTTER</i> <i>FRAISES CARBIDE</i>	Pag. 14
	MOLE PER METALLO E GOMMA <i>WHEELS FOR METALLIC AND RUBBER</i> <i>MEULES POUR MÉTAL ET CAOUTCHOUC</i>	Pag. 16
	SPAZZOLE <i>BRUSHES</i> <i>BROSSES</i>	Pag. 20
	GAMBI PORTAUTENSILI <i>STEM TOOL-CARRIER</i> <i>TIGES PORTE-OUTILS</i>	Pag. 22
	SMERIGLIATRICI PROFESSIONALI <i>PROFESSIONAL GRINDERS</i> <i>PONCEUSES PROFESSIONNELLES</i>	Pag. 24
	RULLINI, RASPETTE E PUNTE IN ACCIAIO <i>STITCHERS, RASPS AND STEEL NAILS</i> <i>ROULEAUX, RÂPES ET AUGUILLES ACIER</i>	Pag. 26
	PORTALAMETTE E LAMETTE <i>TYRE TRIMMING TOOLS AND TRIMMING BLADES</i> <i>PORTE-LAMES ET LAMES À ÉBARBER</i>	Pag. 28
	ACCESSORI DA TAGLIO <i>TOOLS FOR CUTTING</i> <i>ACCESSOIRES À COUPER</i>	Pag. 29
	ESTRUSORI PORTATILI <i>PORTABLE EXTRUDERS</i> <i>EXTRUDEUSES PORTATIVES</i>	Pag. 30
	ACCESSORI E RICAMBI VARI <i>ACCESSORIES AND SPARE PARTS</i> <i>ACCESSOIRES ET PIÈCES DE RECHANGE</i>	Pag. 34
	ACCESSORI ANTINFORTUNISTICA <i>ACCESSORIES FOR INDUSTRIAL ACCIDENTS PREVENTION</i> <i>ACCESSOIRES POUR LA PRÉVENTION DES ACCIDENTS SUR LE TRAVAIL</i>	Pag. 45
	MARCATORE ELETTRICO <i>ELECTRIC MARKER</i> <i>DISPOSITIF POUR MARQUER</i>	Pag. 46
	RIGATORI E LAMETTE <i>GROOVERS AND BLADES</i> <i>SCULPTEURS ET LAMES</i>	Pag. 48
	ENVELOPES <i>ENVELOPES</i> <i>ENVELOPES</i>	Pag. 50
	FUSTINI <i>BLADDERS</i> <i>MEMBRANES</i>	Pag. 57
	CAMERE DI COTTURA <i>CURING TUBES</i> <i>CHAMBRES DE CUISSON</i>	Pag. 58
	MATERIALE AUTOVULCANIZZANTE ITALREPAIR <i>ITALREPAIR SELF-CURING MATERIAL</i> <i>MATERIEL AUTOVULCANISANT ITALREPAIR</i>	Pag. 60

LAME DI RASPATURA ITALMATIC

ITALMATIC BUFFING BLADES

LAMES DE RÂPAGE ITALMATIC

Le lame di rasatura Italmatic vengono prodotte presso la sede di Milano/Italia con acciaio di alta qualità C100 made in Germany per assicurare le migliori prestazioni di rasatura e di durata.

Italmatic buffing blades are produced at our Head Office of Milan/Italy with high quality C100 steel made in Germany to assure the best buffing performance and the longest life.

Les lames de râpage Italmatic sont produites auprès de nt. siège à Milan/Italie avec acier de haute qualité C100 made in Germany afin d'assurer les meilleures performances de râpage et de durée.



Codice Code Code	Modello Model Modèle	Numero lame per set Number of blades per set Numéro de lames par jeu	Numero set per scatola Number of sets per box Numéro de jeux par boîte	Numero lame per scatola Number of blades per box Numéro de lames par boîte
2020010	I - 3 - 25	28	50	1.400
2020011	I - 3 - 24	28	50	1.400
2020013	I - 156 - 17/18	32	50	1.600



Codice Code Code	Modello Model Modèle	Numero lame per set Number of blades per set Numéro de lames par jeu	Numero set per scatola Number of sets per box Numéro de jeux par boîte	Numero lame per scatola Number of blades per box Numéro de lames par boîte
2020014	Long life II US (I-4-20)	28	50	1.400
2020015	I - 4 - 25	28	50	1.400
2020016	I - 4 - 24	28	50	1.400
2020017	I - 4 - 16	28	50	1.400
2020018	Long life II EUROPA	28	50	1.400

LAME DI RASPATURA ITALMATIC
ITALMATIC BUFFING BLADES
LAMES DE RÂPAGE ITALMATIC

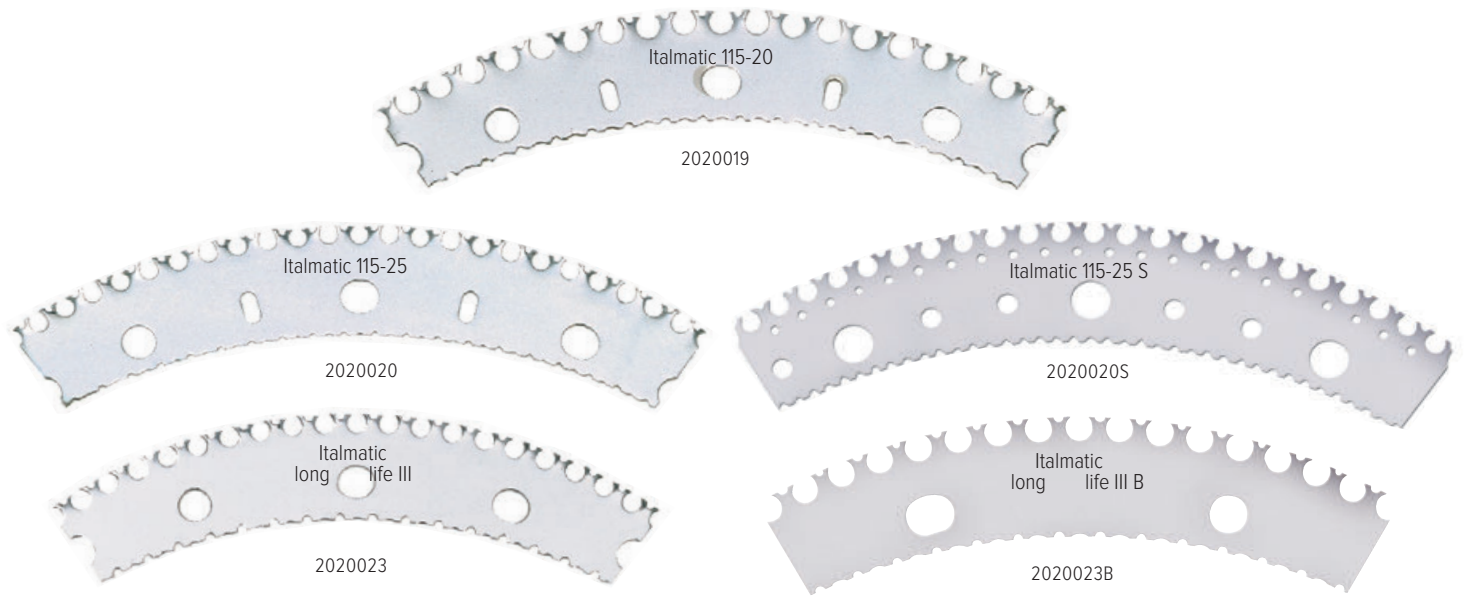

Codice Code Code	Modello Model Modèle	Numero lame per set Number of blades per set Numéro de lames par jeu	Numero set per scatola Number of sets per box Numéro de jeux par boîte	Numero lame per scatola Number of blades per box Numéro de lames par boîte
2020019	I - 115 - 20	25	50	1.250
2020020	I - 115 - 25	25	50	1.250
2020020S	I - 115 - 25 SUPERVENT	25	50	1.250
2020021	I - 115 - 24	25	50	1.250
2020022	I - 115 - 16	25	50	1.250
2020023	Long life III	30	50	1.500
2020023B	Long life III B	30	50	1.500

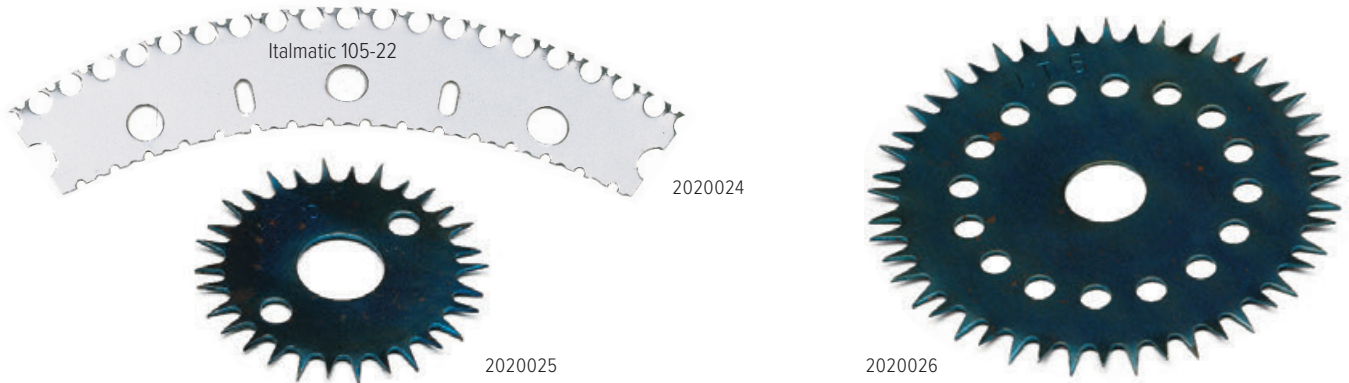

Codice Code Code	Modello Model Modèle	Numero lame per set Number of blades per set Numéro de lames par jeu	Numero set per scatola Number of sets per box Numéro de jeux par boîte	Numero lame per scatola Number of blades per box Numéro de lames par boîte
2020024	I - 105 - 22	35	40	1.400
2020025	I - 5	5	1	5
2020026	I - 6	6	1	6

Codice Code Code	Descrizione Description Description
2020028	Scorticatore diritto/Peeling tooth/Lamette à écorcher
2020029	Affila lama completo di mola Blades sharpener c/w sharpening tool Affûteuse de lames avec meule
2020030	Mola smeriglio per affila lame 150x50x20 Spare sharpening tool for blades sharpener 150x50x20 Meule-émeri pour affûteuse de lames 150x50x20



RASPE ITALMATIC, DISTANZIALI E PERNI

ITALMATIC RASPS, SPACERS AND PINS

RÂPES ITALMATIC, INTERCALAIRES ET GOUJONS

- Su richiesta realizzazione di raspe per qualsiasi esigenza in quanto prodotte presso la nostra sede di Milano/Italia.
- Upon request we manufacture rasps for any need, as they are produced at our Head Office of Milan/Italy.
- Sur demande nous fabriquons râpes pour toutes nécessités, puisque elles sont produites auprès de nt. siège à Milan/Italie.

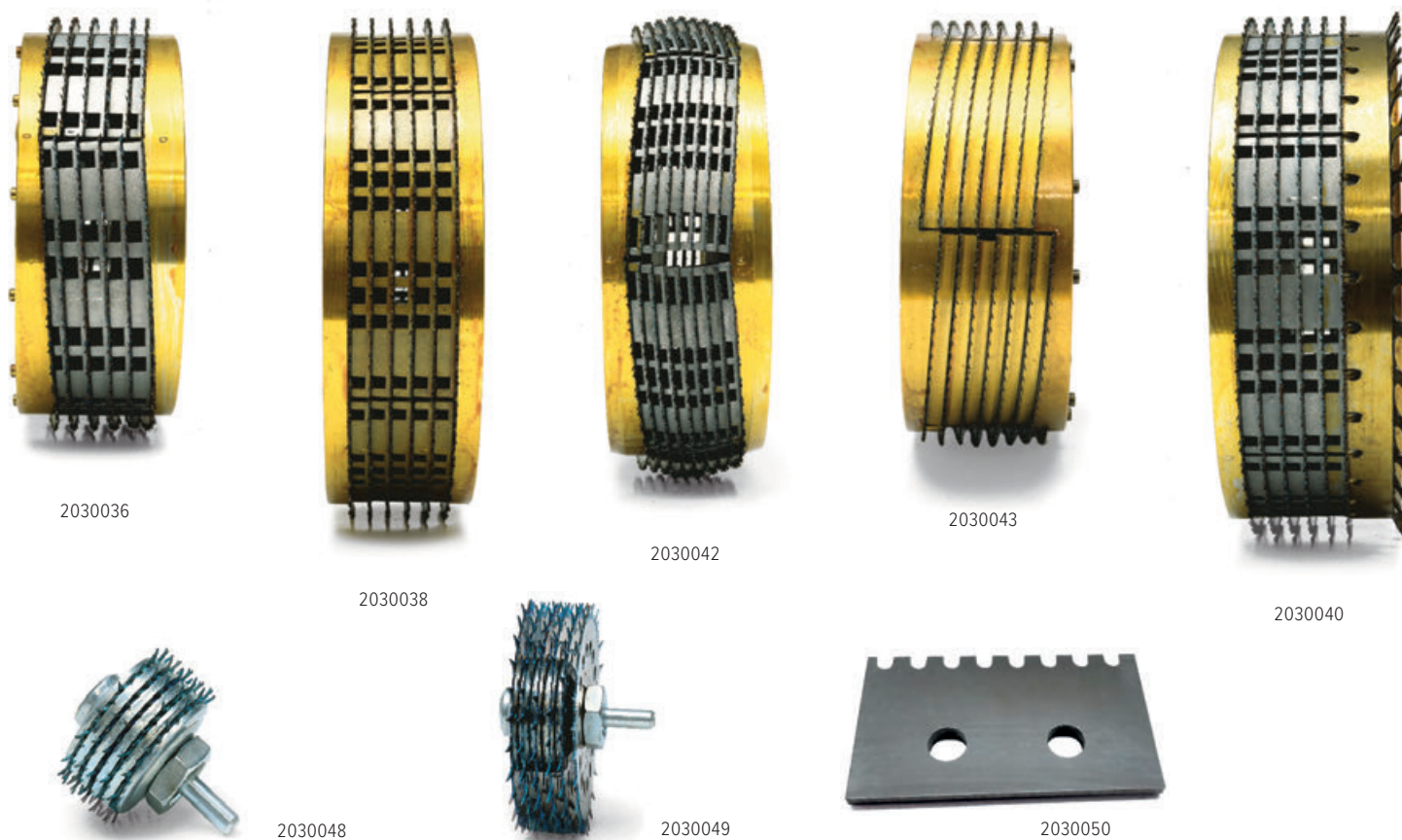

Code Code Code	Modello Model Modèle	Foro Hole Forure	Chiavette Keyways Clavettes	Altezza Height Hauteur	Perni Pins Goujons	Ø esterno Ø external Ø extérieur
2030031	I - 156 - AP	Ø 25	-	H 96	Ø 6,3	155
2030032	I - 4 AP	Ø 32	n° 2 (10 mm)	H 85	Ø 6,3	227
2030033	I - 4 NS	Ø 32	n° 2 (10 mm)	H 85	Ø 6,3	227
2030034	I - 4 NS	Ø 40	n° 2 (10 mm)	H 85	Ø 6,3	227
2030035	I - 4 AP CONVEX	Ø 32	n° 2 (10 mm)	H 96	Ø 6,3	240
2030036	LL II AP BANDAG	Ø 32	n° 2 (10 mm)	H 96	Ø 8	227
2030037	LL II USA AP	Ø 32	n° 2 (10 mm)	H 96	Ø 6,3	227
2030038	I - 115 NS	Ø 32	n° 2 (10 mm)	H 78	Ø 8	291
2030039	I - 115 NS	Ø 40	n° 2 (10 mm)	H 78	Ø 8	291
2030039A	I - 115 NS CONVEX	Ø 55	n° 1 (16 mm)	H 96	Ø 8	305
2030040	I - 115 SPECIAL	Ø 40	n° 2 (10 mm)	H 72	Ø 8	291
	{ con scorticatori c/w peeling teeth avec lamettes à écorcher					
2030041	LL III AP	Ø 40	n° 2 (10 mm)	H 96	Ø 8	291
2030042	LL III AP CONVEX	Ø 40	n° 2 (10 mm)	H 96	Ø 8	305
2030043	I - 105 REGULAR	Ø 32	n° 2 (10 mm)	H 102	Ø 8	267
2030048	I - 5	Ø est. / out. / ext. 43		Gambo / stem / tige Ø 6		43
2030049	I - 6	Ø est. / out. / ext. 74		Gambo / stem / tige Ø 6		74
2030050	CR500 BUFFING HEAD CUTTING BLADES - 4 pcs set	-	-	-	-	-

- In sede d'ordine, per favore specificare spessore distanziali e tipo lama.
- When placing your order, please specify spacers thickness and type of blade.
- Au moment de Vt. commande, svp indiquez épaisseur des intercalaires et type de lame.

Distanziali - Spacers - Intercalaires

Codice Code Code	Modello Model Modèle
2040050	156 x 1/4"
2040051	156 x 3/8"
2040052	4 x 1/4"
2040053	4 x 3/8"
2040054	LL II x 1/4" USA
2040055	LL II x 3/8" USA
2040056	LL II x 1/4" EUROPA
2040057	LL II x 3/8" EUROPA
2040058	105 x 1/4"
2040059	105 x 3/8"
2040060	115 x 1/4"
2040061	115 x 3/8"
2040062	LL III x 1/4"
2040063	LL III x 3/8"

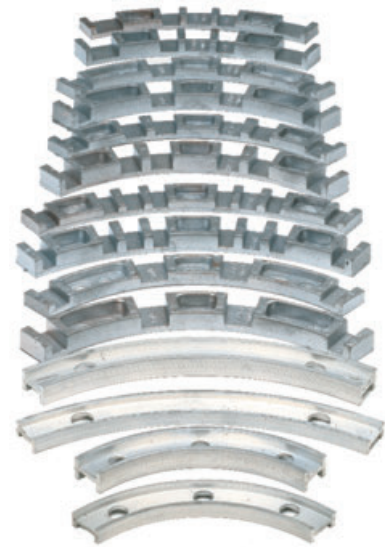

Perni zigrinati - Knurled pins - Goujons crénelés

Codice Code Code	Dimensioni Sizes Dimensions	Tipo raspa Type of rasp Type de râpe
2040065	Ø 6,3 x 85	I - 4
2040066	Ø 6,3 x 96	I - 156 / I - 4
2040067	Ø 6,3 x 102	I - 4
2040068	Ø 8 x 78	I - 115
2040069	Ø 8 x 85	I - 115
2040070	Ø 8 x 96	I - 115 / LL II E / LL III
2040071	Ø 8 x 102	I - 105



Perni zigrinati speciali - Special knurled pins - Goujons crénelés spéciaux

Codice Code Code	Dimensioni / Modello Sizes / Model Dimensions / Modèle	Tipo raspa Type of rasp Type de râpe
2040072	Ø 8 x 72	I - 115 Special
2040073	Perno cilindrico porta scorticatori Cylindrical pin supporting peeling teeth Goujon cylindrique supportant les écorcheurs	
2040074	Perno fresato porta scorticatori Milled pin supporting peeling teeth Goujon fraisé supportant les écorcheurs	



Perni sagomati - Shaped pins - Goujons modelés

Codice Code Code	Dimensioni Sizes Dimensions	Tipo raspa Type of rasp Type de râpe
2040075	Ø 6,3 x 96	I - 4 CONVEX
2040076	Ø 8 x 96	I - 115 / LL III



SCORTICATORI E SGORBIE ITALMATIC

ITALMATIC PEELING TEETH AND GOUGES

ÉCORCHEURS ET GOUGES ITALMATIC



2040080



2040081



2040082



2040082D



2040083B



2040084



2040085

Codice Code Code	Dimensioni Sizes Dimensions	Modello Model Modèle
2040080	Ø 80 x 90 x 40	Scorticatore cilindrico - <i>Cylindrical peeling tooth</i> - <i>Écorcheur cylindrique</i>
2040081	Ø 60 x 70 x 30	Scorticatore cilindrico - <i>Cylindrical peeling tooth</i> - <i>Écorcheur cylindrique</i>
2040082	Ø 70 x 85 x 45	Scorticatore conico <i>Conical peeling tooth</i> <i>Écorcheur conique</i>
2040082A	Ø 100 x 83 x 50 H	Scolpitore conico per Matic PL 20 & PL 80 <i>Conical grooving tooth for Matic PL 20 & PL 80</i> <i>Sculpteur conique pour Matic PL 20 & PL 80</i>
2040082B	210 x 90 x 40 H	Scolpitore conico R 15 per ONE 51 & ONE 63 <i>Conical grooving tooth R 15 for ONE 51 & ONE 63</i> <i>Sculpteur conique R 15 pour ONE 51 & ONE 63</i>
2040082C	210 x 90 x 40 H	Scolpitore conico R 25 per ONE 51 & ONE 63 <i>Conical grooving tooth R 25 for ONE 51 & ONE 63</i> <i>Sculpteur conique R 25 pour ONE 51 & ONE 63</i>
2040082D	210 x 90 x 40 H	Scolpitore conico R 30 per ONE 51 & ONE 63 <i>Conical grooving tooth R 30 for ONE 51 & ONE 63</i> <i>Sculpteur conique R 30 pour ONE 51 & ONE 63</i>
2040083A	178 x 130 x 75 H	Scolpitore riscaldato a ferro di cavallo R15 per Matic PL 20 & PL 80 <i>Heated horse-shoe grooving tooth R15 for Matic PL 20 & PL 80</i> <i>Sculpteur chauffé en forme de fer à cheval R15 pour Matic PL 20 & PL 80</i>
2040083B	Ø 130 x 115 x 53 H	Scorticatore conico per ONE 51 & ONE 63 <i>Cylindrical peeling tooth for ONE 51 & ONE 63</i> <i>Écorcheur cylindrique pour ONE 51 & ONE 63</i>
2040084	Ø est/out/ext 25 Ø int/ins/int 20 - H 45 Gambo/Stem/Tige Ø 7	Sgorbia cilindrica <i>Cylindrical gouge</i> <i>Gouge cylindrique</i>
2040085	Ø est/out/ext 45 Ø int/ins/int 40 - H 45 Gambo/Stem/Tige Ø 7	Sgorbia cilindrica <i>Cylindrical gouge</i> <i>Gouge cylindrique</i>



2040086



2040087



2040087A



2040088



2040090



2040091



2040092

Codice Code Code	Dimensioni Sizes Dimensions	Modello Model Modèle
2040086	Ø est/out/ext 30	Sgorbia a tazza - Cup gouge - Gouge en forme de tasse
2040087	Ø est/out/ext 50	Sgorbia a tazza - Cup gouge - Gouge en forme de tasse
2040087A	Ø est/out/ext 50	Sgorbia a tazza con nocche - Cup gouge with knuckles - Gouge en forme de tasse avec taquets
2040088	Ø est/out/ext 50	Sgorbia a tazza - Cup gouge out - Gouge en forme de tasse
2040090	Ø 30	Movimento terra - E.M. - Terrassement
2040091	Ø 50	Movimento terra - E.M. - Terrassement
2040092	Ø 50	Movimento terra - E.M. - Terrassement
2040093	Ø 25	Mola - Wheel - Meule (6 pz / pcs / pieces)
2040094	—	Affilasgorbie - Gouge sharpening - Affûteuse pour gouge



2040093

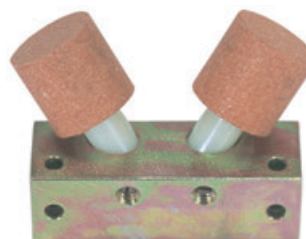

2040094

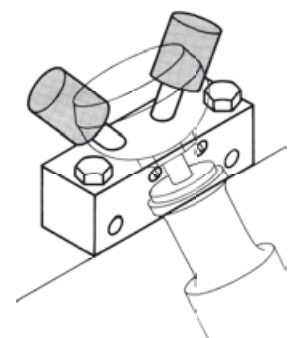

MOLE ED UTENSILI CARBIDE ITALMATIC

ITALMATIC CARBIDE WHEELS AND TOOLS

MEULES ET OUTILS CARBIDE ITALMATIC

- Su richiesta realizzazione di raspe per qualsiasi esigenza in quanto prodotte presso la nostra sede di Milano/Italia.
- Upon request we manufacture rasps for any need, as them are produced at our Head Office of Milan/Italy.
- Sur demande nous fabriquons râpes pour toutes nécessités, puisque elles sont produites auprès de nt. siège à Milan/Italie.

- Per favore specificare sempre il tipo di grana desiderato
- Please always specify the type of grit you desire
- Svp, indiquez toujours le type de grain désiré



UW **Mola combinata** **Unit wheel** **Meule combinée**

Codice Code Code	Dimensioni Sizes Dimensions	Foro Hole Forure
2050100	Ø 50 x 25	14
2050101	Ø 76 x 25	14
2050102	Ø 102 x 25	14
2050103	Ø 102 x 38	14



CW **Mola a profilo curvo** **Contour wheel** **Meule à profil courbe**

Codice Code Code	Dimensioni Sizes Dimensions	Foro Hole Forure
2050110	Ø 50 x 25	3/8" x 24 UNF
2050111	Ø 65 x 13	10
2050112	Ø 76 x 32	14
2050113	Ø 102 x 38	14
2050114	Ø 150 x 38	60



UWF **Mola speciale per raspatura fianchi** **Sidewall buffing wheel** **Meule spéciale pour le râpage des flancs**

Codice Code Code	Dimensioni Sizes Dimensions	Foro Hole Forure	Chiavette Keyways Clavettes
2050120	Ø 150 x 25	60	-
2050121	Ø 150 x 38	32 RTS	n° 2 (10 mm)
2050122	Ø 150 x 38	60	-
2050123	Ø 200 x 25	60	-
2050124	Ø 200 x 38	60	-
2050125	Ø 225 x 25	60	-
2050126	Ø 225 x 38	60	n° 2 (10 mm)
2050127	Ø 270 x 60	32	n° 2 (10 mm)



2050120



2050130

CWG **Mola a profilo curvo** **Contour wheel** **Meule à profil courbe**

Codice Code Code	Dimensioni Sizes Dimensions	Foro Hole Forure
2050130	Ø 150 x 25	60
2050131	Ø 150 x 38	60

RFBOT **Mola rotonda**
Round face buff out tool
Meule ronde

Codice Code Code	Dimensioni Sizes Dimensions	Foro Hole Forure
2050140	Ø 50 x 3,5	3/8" x 24 UNF
2050141	Ø 50 x 5	3/8" x 24 UNF
2050142	Ø 50 x 7	3/8" x 24 UNF
2050143	Ø 50 x 10	3/8" x 24 UNF
2050144	Ø 50 x 13	3/8" x 24 UNF
2050145	Ø 50 x 19	3/8" x 24 UNF
2050146	Ø 70 x 3,5	3/8" x 24 UNF
2050147	Ø 100 x 3,5	3/8" x 24 UNF



CAYMAN **Mola con gambo Cayman**
Cayman wheel c/w stem
Meule Cayman complète de tige

Codice Code Code	Dimensioni Sizes Dimensions	Gambo Stem Tige
2050148	Ø 50 x 3	Ø 6
2050149	Ø 50 x 12	Ø 6



2050148



2050149

TBOTP **Mola conica**
Tapered buff out tool
Meule conique

Codice Code Code	Dimensioni Sizes Dimensions	Foro Hole Forure
2050150	Ø 19 x 38	3/8" x 24 UNF
2050151	Ø 19 x 50	3/8" x 24 UNF
2050152	Ø 25 x 50	3/8" x 24 UNF
2050153	Ø 19 x 102	3/8" x 24 UNF
2050154	Ø 25 x 102	3/8" x 24 UNF



DW **Mola smerigliatura fianchi**
Sidewall buffing wheel
Meule-émeri pour les flancs

Codice Code Code	Dimensioni Sizes Dimensions	Foro Hole Forure
2050158	Ø 50 x 10	10
2050159	Ø 75 x 16	14
2050160	Ø 100 x 13	14
2050161	Ø 100 x 19	18
2050162	Ø 125 x 25	18
2050163	Ø 125 x 25	50
2050163A	Ø 150 x 15	60
2050164	Ø 150 x 32	18
2050165	Ø 150 x 32	60



MOLE ED UTENSILI CARBIDE ITALMATIC

ITALMATIC CARBIDE WHEELS AND TOOLS

MEULES ET OUTILS CARBIDE ITALMATIC

PR Raspetta a matita - Pencil rasp - Râpe en forme de crayon

Codice Code Code	Dimensioni Sizes Dimensions	Gambo Stem Tige
2050170	Ø 6 x 65	Ø 6
2050171	Ø 6 x 102	Ø 6



PRB Raspetta sferica - Ball rasp - Râpe sphérique

Codice Code Code	Dimensioni Sizes Dimensions	Gambo Stem Tige
2050172	Ø 20 x 55	Ø 6



FD Disco piatto - Flat disc - Disque plat

Codice Code Code	Dimensioni Sizes Dimensions	Foro Hole Forure	Note Notes Notes
2050178	Ø 125 x 2	22	-
2050179	Ø 125 x 2	22	Areato - Ventilated - Aéré
2050180	Ø 175 x 2	22	-
2050181	Ø 175 x 2	22	Areato - Ventilated - Aéré
2050182	Ø 200 x 2	30	-



2050178

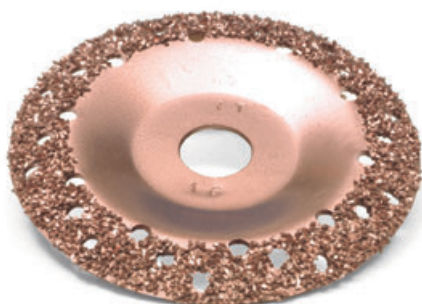

2050181



2050180

ID Tubo carbide/Abrasivo - Carbide tube/Abrasive - Tube carbide/Abrasif

Codice Code Code	Dimensioni Sizes Dimensions	Spessore tubo Tube thickness Épaisseur du tube
2050190	Ø 30 x 30 Carbide	2
2050191	Ø 45 x 30 Carbide	2
2050192	Ø 75 x 30 Carbide	2
2050193A	Ø 30 x 30 Abrasive	1
2050193B	Ø 45 x 30 Abrasive	1



2050193A

Adattatore per tubo carbide - Adaptor for carbide tube - Adaptateur pour tube carbide

Codice Code Code	Dimensioni Sizes Dimensions	Gambo Stem Tige
2050194	Ø 30 x 30	Ø 6
2050195	Ø 45 x 30	Ø 6
2050196	Ø 75 x 30	Ø 8



CD **Disco per taglio fascia prestampato**
Abrasive cutting disc for precured tread
Disque à couper la bande prévulcanisée

Codice Code Code	Dimensioni Sizes Dimensions	Foro Hole Forure
2050199	Ø 150 x 2	50
2050200	Ø 160 x 2	32
2050201	Ø 180 x 2	32
2050202	Ø 200 x 2,5	30
2050203	Ø 300 x 3,5	35



2050200

GW **Mola per rettifica pneumatici**
Wheel for tyres' grinding machine
Meule pour rectifieuse

Codice Code Code	Dimensioni Sizes Dimensions	Foro Hole Forure
2050210	Ø 145 x 150	30
2050211	Ø 160 x 60	32



2050211

SW **Mola a stella - Star wheel - Meule en forme d'étoile**

Codice Code Code	Dimensioni Sizes Dimensions	Foro Hole Forure
2050219	Ø 57 x 9,5	10
2050220	Ø 150 x 5 x 15 H	60
2050221	Ø 150 x 5 x 30 H	60
2050222	Ø 200 x 6	125
2050223	Ø 225 x 6	70/150
2050224	Ø 245 x 6	70/150



2050219

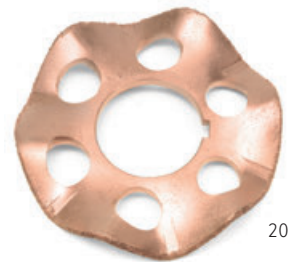

2050221

RG **Mola carbide per sgrossare e rettificare i cilindri rivestiti in gomma**
Carbide wheel to rough and to grind rubberized cylinders
Meule carbide pour dégrossir et pour rectifier les cylindres habillés en caoutchouc

Codice Code Code	Dimensioni Sizes Dimensions	Grana Grit Grain	Foro Hole Forure
2050230	Ø 160 x 40	60 / 16	on request
2050231	Ø 200 x 40	60 / 16	on request
2050232	Ø 250 x 60	80 / 18	on request
2050233	Ø 400 x 60	60 / 16	on request



2050232

Adattatore per mole - Adaptor for wheels - Adaptateur pour meules

Codice Code Code	Dimensioni Sizes Dimensions	Gambo Stem Tige	Mole corrispondenti Corresponding wheels Meules correspondantes
2050240	Ø 3/8" x 24 UNF H 47	Ø 6	RFBOT / CW
2050241	Ø 1/2" w H 52	Ø 6	I-5 / I-6 blades
2050242	Ø10 mm H 60	Ø 6	CW 65 x 13
2050243	M 14x2 H 80	Ø 8	CW 76 x 32



2050240

2050241



2050242

2050243

– Su richiesta realizzazione di boccole per qualsiasi esigenza
 – Upon request manufacturing of bushings for any need
 – Sur demande fabrication de boucles pour toutes nécessités

FRESE CARBIDE
CARBIDE CUTTER
FRAISES CARBIDE

Mole profilo curvo in MCM
Flared contour wheels MCM coated
Meules pour le polissage recouvertes en MCM

Codice Code Code	MCM MCM MCM	Dimensioni Size Dimensions	Foro Hole Alésage
2050234	70	76 x 32	3/8"
2050235	90	76 x 32	3/8"
2050236	70	89 x 38	3/8"
2050237	90	89 x 38	3/8"



2050234



2050235



Frese per metallo
Carbide Cutters
Fraises à métaux

Codice Code Code	Dimensioni Size Dimensions	Modello Model Modèle
3070108AB	Ø 10 x 100	A punta - Pointed - Pointu
3070108C	Ø 8 x 80	A punta - Pointed - Pointu
3070108B	Ø 6 x 80	A punta - Pointed - Pointu
3070108AD	Ø 4,76 x 78	A punta - Pointed - Pointu
3070108AE	Ø 6,35 x 70	A punta piana - Flat router - Sans coup en bout
3070108C	Ø 6,35 x 70	A punta piana - Flat router - Sans coup en bout
3070108E	Ø 9 x 100	A punta - Pointed - Pointu
3070108AF	Ø 11 x 130	A punta - Pointed - Pointu
3070108AG	Ø 12 x 130	A punta - Pointed - Pointu
3070108AH	Ø 13 x 130	A punta - Pointed - Pointu
3070108AT	Ø 6 x 65	A punta - Pointed - Pointu
3070108KIT	Ø 3+4,5+6+8+10	A punta - Pointed - Pointu



3070108KIT

Trapano a pistola da 13 mm
13 mm drill
Perceuse pistolet 13 mm

Codice Code Code	Modello Model Modèle	Giri g/min Rpm Tours/min	Peso kg Weight kg poids kg
3070108DR	Trapano - Drill - Perceuse	600	1,1kg



380108DR



Frese carbide
Carbide cutters
Fraises carbide

Codice Code Code	Descrizione Description Description	Ø	Lunghezza Length Longueur	Gambo Stem Tige	Tipo Type Type
3070108EA	Frese carbide EUROPA / Carbide cutters EUROPA / Fraises carbide EUROPA	20	6	6	sferica / spherical / spherique
3070108EB	Frese carbide EUROPA / Carbide cutters EUROPA / Fraises carbide EUROPA	3	50	3	a punta / pointed / pointu
3070108EC	Frese carbide EUROPA / Carbide cutters EUROPA / Fraises carbide EUROPA	4,5	90	6	a punta / pointed / pointu
3070108ED	Frese carbide EUROPA / Carbide cutters EUROPA / Fraises carbide EUROPA	6	65	6	a punta / pointed / pointu
3070108EE	Frese carbide EUROPA / Carbide cutters EUROPA / Fraises carbide EUROPA	6	90	6	a punta / pointed / pointu
3070108EF	Frese carbide EUROPA / Carbide cutters EUROPA / Fraises carbide EUROPA	8	90	8	a punta / pointed / pointu
3070108EG	Frese carbide EUROPA / Carbide cutters EUROPA / Fraises carbide EUROPA	10	110	10	a punta / pointed / pointu
3070108EH	Frese carbide EUROPA / Carbide cutters EUROPA / Fraises carbide EUROPA	11	100	10	a punta / pointed / pointu
3070108EJ	Frese carbide EUROPA / Carbide cutters EUROPA / Fraises carbide EUROPA	12	100	10	a punta / pointed / pointu
3070108EK	Frese carbide EUROPA / Carbide cutters EUROPA / Fraises carbide EUROPA	13	100	10	a punta / pointed / pointu
3070108EL	Frese carbide EUROPA / Carbide cutters EUROPA / Fraises carbide EUROPA	17	140	-	a punta / pointed / pointu
3070108EM	Frese carbide EUROPA / Carbide cutters EUROPA / Fraises carbide EUROPA	22	140	-	a punta / pointed / pointu
3070108EN	Frese carbide EUROPA / Carbide cutters EUROPA / Fraises carbide EUROPA	10	100	10	a punta / pointed / pointu
3070108EP	Frese carbide EUROPA / Carbide cutters EUROPA / Fraises carbide EUROPA	8	100	8	smussata / chamfered / chanfreinés
3070108EQ	Frese carbide EUROPA / Carbide cutters EUROPA / Fraises carbide EUROPA	8	100	8	a punta / pointed / pointu
3070108ER	Frese carbide EUROPA / Carbide cutters EUROPA / Fraises carbide EUROPA	6	80	6	a punta / pointed / pointu
3070108ES	Frese carbide EUROPA / Carbide cutters EUROPA / Fraises carbide EUROPA	3	70	3	a punta / pointed / pointu
3070108ET	Frese carbide EUROPA / Carbide cutters EUROPA / Fraises carbide EUROPA	3	50	3	a punta / pointed / pointu

MOLE PER METALLO E GOMMA
WHEELS FOR METALLIC AND RUBBER
MEULES POUR MÉTAL ET CAOUTCHOUC

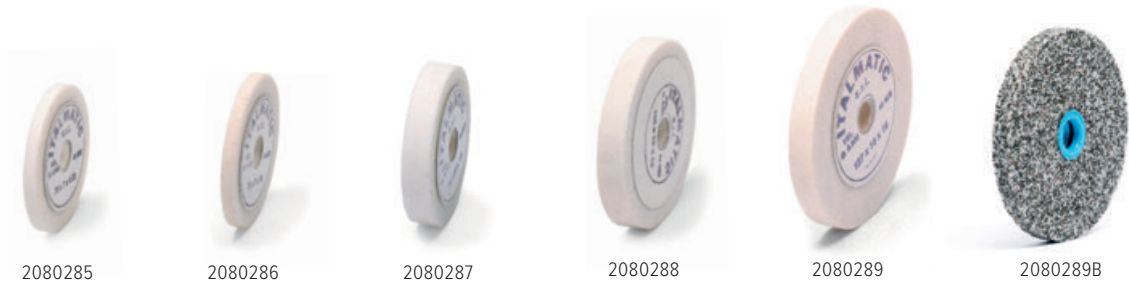

Mole per metallo - Wheels for metallic - Meules pour métal

Codice Code Code	Dimensioni Sizes Dimensions	Foro Hole Forure	Gambo Stem Tige	Giri min. R.p.m. Tours min.	Descrizione Description Description
2080285	Ø 75 x 7	Ø 9,53	-	8.390	A disco bianca / white Disc / À disque blanche
2080285R	Ø 75 x 7	Ø 9,53	-	8.390	A disco rosso rubino / ruby red Disc / À disque rouge rubis
2080286	Ø 75 x 7	Ø 16	-	8.390	A disco bianca o gialla / white or yellow Disc / À disque blanche ou jaune
2080287	Ø 75 x 15	Ø 16	-	8.390	A disco bianca / white Disc / À disque blanche
2080287B	Ø 90 x 16	Ø 16	-	8.390	Mola per metallo bianca / white Wheel for metallic / meule pour métal blanche
2080287D	Ø 100 x 10	Ø 10	-	8.390	Mola per metallo bianca / white Wheel for metallic / meule pour métal blanche
2080288	Ø 100 x 16	Ø 16	-	6.300	A disco bianca / white Disc / À disque blanche
2080289	Ø 127 x 16	Ø 16	-	5.040	A disco bianca / white Disc / À disque blanche
2080289B	Ø 100 x 10	Ø 14	-	5.040	Mola per metallo bianca / white Wheel for metallic / meule pour métal blanche
2080290	Ø 30 x 6	-	Ø 6	21.000	Mola-metallo a disco marrone / brown Disc wheel-metallic / bleu pour métal à disque marron
2080290C	Ø 30 x 6	-	Ø 6	21.000	Mola-metallo a disco rosa / pink Disc wheel-metallic / meule pour métal à disque rose
2080290E	Ø 30 x 6	-	Ø 6	21.000	Mola-metallo a disco bianca / white Disc wheel-metallic / meule pour métal à disque blanche
2080290K	Ø 35 x 6	-	Ø 6	21.000	Mola-metallo a disco bianca / white Disc wheel-metallic / meule pour métal à disque blanche
2080290M	Ø 35 x 6	-	Ø 6	21.000	Mola-metallo a disco blu / blue Disc wheel-metallic / bleu pour métal à disque blanche
2080290P	Ø 35 x 6	-	Ø 6	21.000	Mola-metallo a disco marrone / brown Disc wheel-metallic / bleu pour métal à disque marron
2080290R	Ø 25 x 6	-	Ø 6	21.000	Mola-metallo a disco marrone / brown Disc wheel-metallic / bleu pour métal à disque marron

Nota: le mole per metallo sono disponibili su richiesta anche con mescola rosa (più dura)
 Note: wheels for metallic are available on request also in pink compound (harder)
 Note: les meules pour métal sont disponibles sur demande aussi en mélange rose (plus dur)

MOLE PER METALLO E GOMMA
WHEELS FOR METALLIC AND RUBBER
MEULES POUR MÉTAL ET CAOUTCHOUC



Mole per metallo - Wheels for metallic - Meules pour métal

Codice Code Code	Dimensioni Sizes Dimensions	Foro Hole Forure	Gambo Stem Tige	Giri min. R.p.m. Tours min.	Descrizione Description Description
2080291	Ø 35 x 8	-	Ø 6	21.000	Mola-metallo a disco / Disc wheel-metallic / meule pour métal à disque
2080291A	Ø 40 x 10	-	Ø 6	21.000	A disco doppio smusso bianca / white Disc with double bevel / À disque avec double biseau blanche
2080291B	Ø 35 x 6	-	Ø 6	21.000	Mola-metallo a disco rosa / pink Disc wheel-metallic / meule pour métal à disque rose
2080291C	Ø 40 x 10	-	Ø 6	21.000	Mola-metallo a disco doppio smusso rosa pink Disc with double bevel wheel-metallic / meule pour métal à disque avec double biseau rose
2080291D	Ø 35 x 6	-	Ø 6	21.000	Mola-metallo a disco grigia / grey Disc wheel-metallic / meule pour métal à disque gris
2080291E	Ø 40 x 10	-	Ø 6	21.000	Mola-metallo a disco doppio smusso grigia grey Disc with double bevel wheel-metallic / meule pour métal à disque avec double biseau gris
2080291G	Ø 40 x 10	-	Ø 6	21.000	Mola-metallo a disco doppio smusso marrone brown Disc with double bevel wheel-metallic / meule pour métal à disque avec double biseau marron
2080291J	Ø 50 x 6	-	Ø 6	21.000	Mola-metallo a disco bianca / white Disc wheel-metallic / meule pour métal à disque blanche
2080291L	Ø 50 x 6	-	Ø 6	21.000	Mola-metallo a disco rosa / pink Disc wheel-metallic / meule pour métal à disque rose
2080291R	Ø 10 x 30	-	Ø 6	21.000	Mola-metallo Cilindrica rosa / pink Cylindric wheel-metallic / meule pour métal Cylindrique rose
2080292	Ø 20 x 40	-	Ø 6	21.000	Conica bianca / Conical white / Conique blanche
2080292D	Ø 10 x 30	-	Ø 6	21.000	Mola-metallo Cilindrica marrone / brown Cylindric wheel-metallic / meule pour métal Cylindrique marron
2080293	Ø 10 x 30	-	Ø 6	21.000	Conica rosa / Conical pink / Conique rose
2080293B	Ø 8,5 x 27	-	Ø 6	21.000	Conica rosa / Conical pink / Conique rose
2080293F	Ø 10 x 30	-	Ø 6	21.000	Cilindrica viola / Cylindrical purple / Cylindrique violet
2080293K	Ø 10 x 30	-	Ø 6	21.000	Mola-metallo conica bianca / white conical wheel metallic
2080294	Ø 40 x 30	-	Ø 6	21.000	Cilindrica bianca / Cylindrical white / Cylindrique blanche

Nota: le mole per metallo sono disponibili su richiesta anche con mescola rosa (più dura)

Note: wheels for metallic are available on request also in pink compound (harder)

Note: les meules pour métal sont disponibles sur demande aussi en mélange rose (plus dur)

MOLE PER METALLO E GOMMA
WHEELS FOR METALLIC AND RUBBER
MEULES POUR MÉTAL ET CAOUTCHOUC



2080294B



2080294C



2080295



2080295J



2080295K



2080295L



2080296



2080297



2080298



2080299

Mole per metallo - Wheels for metallic - Meules pour métal

Codice Code Code	Dimensioni Sizes Dimensions	Foro Hole Forure	Gambo Stem Tige	Giri min. R.p.m. Tours min.	Descrizione Description Description
2080294A	Ø 50 x 10	-	Ø 6	21.000	Cilindrica doppio smusso rosso rubino <i>ruby red Cylindrical double bevel / Cylindrique double biseau rouge rubis</i>
2080294B	Ø 50 x 12	-	Ø 6	21.000	Mola-metallo Cilindrica blu / <i>blue Cylindric wheel-metallic / bleu pour métal Cylindrique rose</i>
2080294C	Ø 50 x 12	-	Ø 6	21.000	Cilindrica nera / <i>black Cylindrical / Cylindrique noire</i>
2080295	Ø 50 x 12	-	Ø 6	21.000	Cilindrica bianca o gialla / <i>white or yellow Cylindrical / Cylindrique blanche ou jaune</i>
2080295A	Ø 20	-	Ø 6	21.000	Sferica viola / <i>purple Spheric / Sphérique violet</i>
2080295B	Ø 40	-	Ø 6	21.000	Sferica gialla / <i>yellow Spheric / Sphérique jaune</i>
2080295J	Ø 34 x 6	-	Ø 6	21.000	Mola-metallo a disco bianca / <i>white Disc wheel-metallic / meule pour métal à disque blanche</i>
2080295K	Ø 25 x 6	-	Ø 6	21.000	Mola-metallo a disco bianca / <i>white Disc wheel-metallic / meule pour métal à disque blanche</i>
2080295L	Ø 20 x 65	-	Ø 6	21.000	Mola-metallo conica bianca <i>white conical wheel-metallic / meule pour métal conique blanche</i>
2080296	Ø 20 x 65	-	Ø 6	21.000	Cilindro-conica verde o marrone / <i>green or brown Cylinder-conical / Cylindre-conique verte ou marron</i>
2080297	Ø 8 x 25	-	Ø 6	21.000	A punta bianca / <i>white Pointed / À pointe blanche</i>
2080298	Ø 8 x 25	-	Ø 6	21.000	A punta marrone / <i>brown Pointed / À pointe marron</i>
2080299	Ø 40 x 12	-	Ø 6	21.000	Mola-metallo Cilindrica bianca / <i>white Cylindric wheel-metallic / bleu pour métal Cylindrique blanche</i>

Nota: le mole per metallo sono disponibili su richiesta anche con mescola rosa (più dura)

Note: wheels for metallic are available on request also in pink compound (harder)

Note: les meules pour métal sont disponibles sur demande aussi en mélange rose (plus dur)



2080300



2080300C



2080301



2080302



2080303

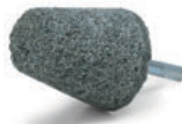

2080304



2080305



2080306



2080306A



2080306C



2080307

Mole per gomma - Wheels for rubber - Meules pour caoutchouc

Codice Code Code	Dimensioni Sizes Dimensions	Foro Hole Forure	Gambo Stem Tige	Giri min. R.p.m. Tours min.	Descrizione Description Description
2080300	Ø 100 x 25	Ø 16	-	6.300	A disco verde / Disc green / À disque verte
2080300C	Ø 127 x 16	Ø 16	-	7.640	A disco nera bak / Disc bak black / À disque noire bak
2080301	Ø 127 x 25	Ø 16	-	5.040	A disco verde / Disc green / À disque verte
2080302	Ø 100 x 25	Ø 16	-	6.300	A disco bianca / Disc white / À disque blanche
2080303	Ø 127 x 25	Ø 16	-	5.040	A disco bianca / Disc white / À disque blanche
2080304	Ø 40 x 50	-	Ø 6	15.670	Conica verde / Conical green / Conique verte
2080305	Ø 50 x 18	-	Ø 6	12.600	Cilindrica verde / Cylindrical green / Cylindrique verte
2080306	Ø 35	-	Ø 6	21.000	Sferica verde / Spherical green / Sphérique verte
2080306A	Ø 40	-	Ø 6	21.000	Sferica bianca emulsione ceramica Spheric white ceramic emulsion / Sphérique blanche émulsion céramique
2080306C	Ø 20	-	Ø 6	21.000	Sferica verde / Spherical green / Sphérique verte
2080307	Mola CARBORUNDUM nera con impugnatura CARBORUNDUM black grinding stone with handle Meule CARBORUNDUM noire avec poignée				mm 150 x 50 x 23 mm 150 x 50 x 23 mm 150 x 50 x 23

SPAZZOLE

BRUSHES

BROSSES



2070271



2070272



2070273

Spazzole con gambo Brushes c/w stem Brosses complètes de tige

Codice Code Code	Dimensioni Sizes Dimensions	Foro Hole Forure	Giri min. R.p.m. Tours min.
2070271	Ø 40 x 15	Ø 6	15.000
2070272	Ø 50 x 15	Ø 6	15.000
2070273	Ø 60 x 15	Ø 6	15.000

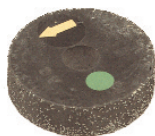

2070277



2070278



2070279

Spazzole gommate con fili di acciaio Rubber brushes c/w steel wires Brosses habillées en caoutchouc avec câbles en acier

Codice Code Code	Dimensioni Sizes Dimensions	Foro Hole Forure	Giri min. R.p.m. Tours min.
2070277	2" Ø 50 x 6,6	Ø 12,7	12.000
2070278	3" Ø 75 x 6,6	Ø 12,7	10.000
2070279	4" Ø 100 x 12,7	Ø 12,7	8.000
2070280	6" Ø 150 x 25	Ø 25,4	6.000



2070300



2070301



2070302



2070303

Spazzole abrasive Abrasive brushes Brosses abrasives

Codice Code Code	Dimensioni Sizes Dimensions	Gambo Stem Tige
2070300	Ø 30 x 20	Ø 6
2070301	Ø 50 x 30	Ø 6
2070302	Ø 40 x 20	Ø 6
2070303	Ø 60 x 30	Ø 6



Spazzole ottonate
Brass brushes
Brosses cuivrées

Codice Code Code	Riferimento Reference Référence	Dimensioni Sizes Dimensions	Foro interno Inside hole Forure intérieure	Foro con flange Hole with flanges Forure avec brides	Giri min. R.p.m. Tours min.	Modello Model Modèle
2070260	R 4103	100 x 25	Ø 40	Ø 16	6.000	Lit Kullen
2070261	R 8153	150 x 30	Ø 80	Ø 25	6.000	Lit Kullen
2070261B	R 8154	150 x 35	Ø 77	Ø 25	6.000	Lit Kullen
2070262	R 6154 W	150 x 40	Ø 60	Ø 18,5	6.000	Lit Kullen
2070263	R 8167	160 x 60	Ø 80	Ø 25	6.000	Lit Kullen
2070263B	R 8185	180 x 45	Ø 77	Ø 25	6.000	Lit Kullen
2070263D	R 8204	200 x 40	Ø 77	Ø 25	3.600	Lit Kullen
2070263F	–	200 x 40	Ø 100	Ø 32	3.600	–
2070264	R 10223 B	225 x 35	Ø 100	Ø 32	3.600	Lit Kullen
2070265	R 10236 B	230 x 60	Ø 100	Ø 32	3.600	Lit Kullen

GAMBI PORTA-UTENSILI

STEMS TOOL-CARRIER

TIGES PORTE-OUTILS

Gambo porta-utensili Tool holder stem Tiges porte-outils

Codice Code Code	Dimensioni Sizes Dimensions	Gambo Stem Arbre
2050240A	M 12 x 10	Ø 6
2050240B	M 10 x 16	Ø 6
2050240C	3/8" UNF x 25	Ø 6
2050240D	M 16 x 40	Ø 6
2050240E	M 14 x 40	Ø 6
2050240F	M 14 x 25	Ø 8
2050240G	M 14 x 15	Ø 6
2050240H	M 12 x 25	Ø 8



Ricambi Salvadori Salvadori spare parts Pièces de rechange Salvadori

Codice Code Code	Ø mm Ø mm Ø mm	Descrizione Details Description
2050240J	Ø 10	Albero flessibile / Flexible spindle / Arbre flexible
2050240K	Ø 10	Corda interna / Inner chord / Corde intérieure
2050240L	Ø 12	Albero flessibile / Flexible spindle / Arbre flexible
2050240M	Ø 12	Corda interna / Inner chord / Corde intérieure
2050240N	Ø 15	Albero flessibile / Flexible spindle / Arbre flexible
2050240P	Ø 15	Corda interna / Inner chord / Corde intérieure



Gambo speciale per flessibili Ø 12-15 Special stem for flexible drive Ø 12-15 Tige spéciale pour tuyaux souples Ø 12-15

Codice Code Code	Modello Model Modèle
2050240Q	Attacco cono per flessibile Ø 12-15 (filetto 3/8 UNF) Stem for flexible drive Ø 12-15 / Tige speciale pour tuyaux souples Ø 12-15



Gambo speciale per flessibili Ø 10 Special stem for flexible drive Ø 10 Tige spéciale pour tuyaux souples Ø 10



Codice Code Code	Impiego Use Emploi
2050240R	Per spazzola ad anello per flessibile Ø 100 / For 100 mm ring brush for flexible drive / Pour brosse Ø 100
2050240S	Per raspetta a punta intercambiabili / For rasp with replaceable points / Pour râpe à pointes interchangeables
2050240T	Per lame 6 / For 6 blades / Pour lame 6
2050240V	Per mandrino / For chuck / Pour mandrin
2050240W	Alberino supporto sgorbie Ø 30-50 / Gouge carrier stem / Arbre porte-gouges Ø 30-50

Gambi esagonale porta - utensili per cod. 539
Hexagonal stem tool - carrier for code 539
Tige hexagonale porte - outils pour code 539

Codice Code Code	Impiego Use Emploi
3070108X1	Attacco per adattatori innesto rapido 3/8" unf / Connection thread 3/8@ unf / Raccord 3/8" unf
3070108X4	Gambo esagonale porta-utensile per mole con gambo Ø 6 mm Hexagonal stem tool-carrier for grinding wheels with a stem of Ø 6 mm Tige hexagonale porte-outils pour meules avec une tige de Ø 6 mm
3070108X5	Per mole con gambo Ø 8 For grinder-wheel with stem Ø 8 / Pour meules avec arbre Ø 8
3070108X6	Gambo esagonale porta-utensile per mole con gambo Ø 10 mm Hexagonal stem tool-carrier for grinding wheels with a stem of Ø 10 mm Tige hexagonale porte-outils pour meules avec une tige de Ø 10 mm
3070108X7	3/8" UNF x 25 mm
3070108X8	3/8" UNF x 16 mm
3070108X9	Ø 14 x 15 mm
3070108X10	Adattatore lame I6 / Adaptor I-6 blades / Raccord pour I-6 lames
3070108X12	Per mole con gambo Ø 6 For grinder-wheel with stem Ø 6 / Pour meules avec arbre Ø 6
3070108X13	Gambo esagonale porta-utensile per mole 3/8" Hexagonal stem tool-carrier for grinding wheels with 3/8" Tige hexagonale porte-outils pour meules de 3/8"
3070108X14	3/8" UNF
3070108X15	Ø 10 x 20 mm
3070108X16	Ø 12 x 20 mm
3070108X18	Supporto sgorbie 30-50 Ø / Adaptor for tools 30-50 Ø
3070108X19	Alberino supporto sgorbie EM Gouge carrier stem EM / Arbre de soutien gouges EM
3070108X20	Ø 13 X 20 mm
3070108X22	Ø 16 x 25 mm
3070108X23	Ø 20 x 30 mm
3070108X24	Adattatore per 2090318 / Adaptor for 2090318
3070108X25	Adattatore per spazzole foro 32 mm / Adaptor for tools / Raccord pour outil
3070108X27	Adattatore per spazzole ad anello / Adaptor for tools / Raccord pour outil



3070108X10



3070108X25



3070108X23



3070108X24



3070108X27



SMERIGLIATRICI PROFESSIONALI
PROFESSIONAL GRINDERS
PONCEUSES PROFESSIONNELLES



2100330



2100331

2100331D



2100332

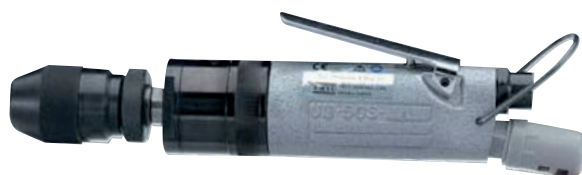

2100333

Smerigliatrici professionali ad alte prestazioni URYU
Professional grinders high performances URYU
Ponceuses professionnelles à hautes performances URYU

Codice Code Code	Modello Model Modèle	Giri min R.p.m. Tours min.	Peso kg Weight kg Poids kg	Watt Watt Watt	Consumo aria L/Min. Air consumption L/min. Consommation air L/min.	Attacco aria Air connection Connexion air	db db db	Utilizzo Utilization Utilisation
2100330	UG 38 NA	25.000	0,65	315	400	1/4"	75	Pneum. vettura / Car tyres / Pneus tourisme
2100331	UG 65 EBR	14.600	1,5	412	600	1/4"	95	Pneum. vettura / Car tyres / Pneus tourisme
2100332	UG 125 OL	7.200	3,2	750	900	1/4"	88	Pneum. giganti / Truck tyres / Pneus camion
2100333	UD 50S 45	5.000	0,85	0,18	400	1/4"	77	Pneum. vettura / Car tyres / Pneus tourisme

2100331D Scarico aria silenziatore per cod. 2100331 / Silencing air release for code 2100331 / Purge air silencieuse pour code 2100331

Nota: per smerigliatrici a 4.000 e 22.000 giri/min. vedere codici 3060896G e 3070108S

Note: for grinders at 4.000 and 22.000 r.p.m. see codes 3060896G and 3070108S

Note: pour ponceuses de 4.000 et 22.000 tours/min. voir les codes 3060896G et 3070108S

Optionals e parti di ricambio
Optionals and spare parts
Options et pièces de rechange

Codice Code Code	Descrizione Description Description
2100343	Pinza per smerigliatrice UG 65 EBR mm 6 Pliers for grinder UG 65 EBR mm 6 Pincés pour ponceuse UG 65 EBR mm 6
2100344	Pinza per smerigliatrice UG 65 EBR mm 8 Pliers for grinder UG 65 EBR mm 8 Pincés pour ponceuse UG 65 EBR mm 8
2100345	Mandrino autobloccante 0-8mm attacco 3/8" 24UNF Self-locking chuck 0-8mm connection 3/8" 24UNF Mandrin à blocage automatique 0- mm connexion 3/8" 24UNF
2100346	Mandrino a cremagliera 0-8mm attacco 3/8" 24UNF Rack chuck 0-8mm connection 3/8" 24UNF Mandrin à crémaillère 0-8mm connexion 3/8" 24UNF



2100343



2100345



2100344



2100346

3030161W



3030161Z

Smerigliatrici Ingersoll
Ingersoll grinders
Ponceuses Ingersoll

Codice Code Code	Descrizione Description Description	Modello Model Modèle	Coppia max di torsione Max torque Couple de torsion max	Giri al minuto R.P.M. Tours/min.	Peso kg. Weight kg. Poids kg.
3030161W	Smerigliatrice 4.500rpm mandrino standard 10mm Grinder 4500 rpm standard chuck 10mm Ponceuse 4500 tours/min. mandrin standard 10mm	LA410-EU	2	4.500	0,91
3030161Z	Smerigliatrice ultraleggera 28.000 rpm pinze 1/4" e 6mm, potente motore da 0.19 KW (0.25 HP) / Ultralight grinder 28000 rpm pliers 1/4" and 6mm, powerful motor 0.19 KW (0.25 HP) Ponceuse ultralégère 28000 tours/min. pinces 1/4 » et 6mm, moteur puissant à 0.19 KW (0.25 HP)	307B	–	28.000	0,33



3070108S



3070108T



3070108U



3070108V

Smerigliatrici
Grinders
Ponceuse

Codice Code Code	Descrizione Description Description	rpm	Attacco mm Connection mm Connection mm	Potenza (HP) Power Puissance	Peso kg Weight Poids
3070108S	Smerigliatrice economica Cheap grinder / Ponceuse économique	23000	6	0,45	0,57
3070108T	Smerigliatrice professionale Professional grinder / Ponceuse professionnelle	25000	6	0,3	0,4
3070108U	Smerigliatrice professionale angolare Professional angular grinder Ponceuse professionnelle angulaire	20000	6	0,3	0,5
3070108V	Trapano reversibile Reversible drill / Perceuse reversible	2000	10	–	1
3070108W	Smerigliatrice bassi giri per frese - Ingersoll 327LS Grinder low speed for carbide cutters - Ingersoll 327LS Ponceuse basse Vitesse pour fraises carbide - Ingersoll 327LS	3000	hex 7/16	0,38	–
3070108X	Aspirapolvere per ispezionatrice Hoover for inspection machine Aspirateur pour machine à inspecter	–	–	–	–

RULLINI, RASPETTE E PUNTE IN ACCIAIO

STITCHERS, RASPS AND STEEL NAILS

ROULEAUX, RÂPES ET AIGUILLES ACIER

Rullini a punte intercambiabili
Stitchers with interchangeable pins
Rouleaux à aiguilles interchangeables



2090310



2090311



2090312



2090313

Codice Code Code	Dimensioni Sizes Dimensions	Punta Pin Aiguille
2090310	Ø 52 x 12	1,5 x 12 cod. 2010003
2090311	Ø 52 x 18	1,5 x 12 cod. 2010003
2090312	Ø 52 x 27	1,5 x 12 cod. 2010003
2090313	Ø 52 x 46	1,5 x 12 cod. 2010003
2090314	Ø 52 x 76	1,5 x 12 cod. 2010003



2090314

Raspette a punte intercambiabili
Rasps with interchangeable pins
Râpes à aiguilles interchangeables

Codice Code Code	Dimensioni Sizes Dimensions	Punta Pin Aiguille	Descrizione Description Description
2090316	Ø 47 x 48	1,5 x 10	Conica / Conical / Conique
2090317	Ø 39	1,5 x 12	Sferica / Spherical / Sphérique
2090318	Ø 75 x 34	1,5 x 12	Bombata / Convex / Bombée
2090319	Ø 52 x 18	-	Rinforzo in gomma per raspa bombata <i>Rubber reinforcement for convex rasp</i> <i>Renfort en caoutchouc pour râpe bombée</i>



2090316



2090317



2090318



2090319

Punte in acciaio per rullini e raspette
Steel nails for stitchers and rasps
Aiguilles en acier pour rouleaux et râpes

Codice Code Code	Dimensioni Sizes Dimensions	Confezione Box Conditionnement
2010002	1,5 x 10	3.000 pcs.
2010003	1,5 x 12	3.000 pcs.
2010004	2 x 17	5.000 pcs.
2010008	2 x 22	10.000 pcs.



Rullini zigrinati, lisci e da taglio
Serrated, smooth and cutting stitchers
Rouleaux crénelés, lisses et à couper



2090320

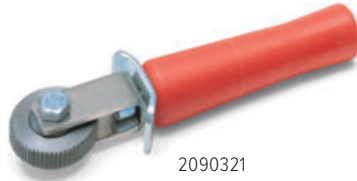

2090321



2090322

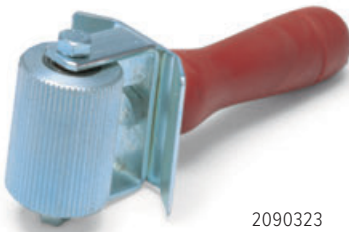

2090323

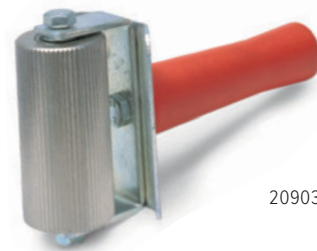

2090324



2090326



2090328



2090329



2090330

Codice Code Code	Dimensioni Sizes Dimensions	Descrizione Description Description
2090320	Ø 40 x 2,5	Zigrinato / Serrated / Crénelé
2090321	Ø 40 x 10	Zigrinato / Serrated / Crénelé
2090322	Ø 40 x 18	Zigrinato / Serrated / Crénelé
2090323	Ø 40 x 46	Zigrinato / Serrated / Crénelé
2090324	Ø 40 x 76	Zigrinato / Serrated / Crénelé
2090325	Ø 40 x 12	Cilindrico liscio / Smooth cylindrical / Lisse cylindrique
2090326	Ø 40 x 18	Cilindrico liscio / Smooth cylindrical / Lisse cylindrique
2090327	Ø 40 x 46	Cilindrico liscio / Smooth cylindrical / Lisse cylindrique
2090328	Ø 40 x 46	Per scanalature / For grooves / Pour rainures
2090329	Ø 50 x 18	Per talloni / For beads / Pour talons
2090330	Ø 60 x 18	Da taglio / For cutting / À couper

PORTALAMETTE E LAMETTE
TYRE TRIMMING TOOLS AND TRIMMING BLADES
PORTE-LAMES ET LAMES À ÉBARBER



Portalamette - Tyre trimming tools - Porte-lames à ébarber

Codice Code Code	Modello Model Modèle	Utilizzo Utilization Utilisation
2120370	Curvo con appoggio regolabile <i>Curved with adjustable support</i> <i>Courbe avec appui réglable</i>	Pneumatici vettura <i>Car tyres</i> <i>Pneus tourisme</i>
2120371	Piatto normale <i>Flat normal</i> <i>Normal plat</i>	Pneumatici vettura <i>Car tyres</i> <i>Pneus tourisme</i>
2120372	Curvo con appoggio regolabile <i>Curved with adjustable support</i> <i>Courbe avec appui réglable</i>	Pneumatici autocarro <i>Truck tyres</i> <i>Pneus camion</i>
2120372B	Speciale ricurvo per lame 2120378B, per raggiungere zone difficili e strette <i>Special curved for blades</i> <i>2120378B, to reach difficult and</i> <i>narrow areas</i> <i>Spécial courbe pour lames</i> <i>2120378B, pour joindre des zones</i> <i>difficiles et étroites</i>	Pneumatici autocarro <i>Truck tyres</i> <i>Pneus camion</i>
2120373	Piatto normale <i>Flat normal</i> <i>Normal plat</i>	Pneumatici autocarro <i>Truck tyres</i> <i>Pneus camion</i>



2120374

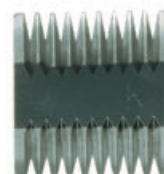

2120375

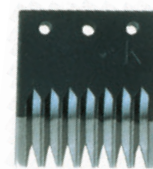

2120376

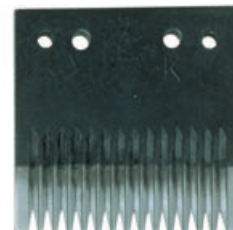

2120377



2120378



2120378B

Lamette - Trimming blades - Lames à ébarber

Codice Code Code	Nr. denti Nr. of teeth Nr. de dents	Descrizione Description Description	Utilizzo Utilization Utilisation
2120374	10	49 x 52	Vettura / Car / Tourisme
2120375	10	49 x 52 doppia curvata <i>double curved</i> <i>double courbe</i>	Vettura / Car / Tourisme
2120376	8	49 x 52	Autocarro / Truck / Camion
2120377	15	75 x 75	Autocarro / Truck / Camion
2120378	15	75 x 75 curvata <i>curved</i> <i>courbe</i>	Autocarro / Truck / Camion
2120378B	5	51 x 25 curvata <i>curved</i> <i>courbe</i>	Autocarro / Truck / Camion



2110350



2110353



2110352

Accessori da taglio
Tools for cutting
Accessories à couper

Codice Code Code	Descrizione Description Description
2110350	Coltello speciale per gomma tipo scimitarra da 9" <i>Bail cutting knife for rubber 9"</i> <i>Couteau spécial pour caoutchouc type cimeterre de 9"</i>
2110351	Coltello speciale per gomma tipo scimitarra da 12" <i>Bail cutting knife for rubber 12"</i> <i>Couteau spécial pour caoutchouc type cimeterre de 12"</i>
2110352	Coltello speciale tipo trincetto O.T. <i>Special knife type O.T.</i> <i>Couteau spécial type tranchet O.T.</i>
2110353	Acciarino affila coltelli <i>Sharpener for knives</i> <i>Affûteuse pour couteaux</i>
2110354	Pietra speciale affila coltelli <i>Special stone for knives sharpening</i> <i>Pierre spéciale pour affûter les couteaux</i>
2110355	Coltello taglia bave a una via <i>Trimming knife - one way</i> <i>Couteau à couper les bavures à une voie</i>
2110356	Taglierino rigido con lama retrattile <i>Stiff cutter with retractable blade</i> <i>Coupoir rigide avec lame rétractile</i>
2110357	Lama di ricambio diritta per taglierino rigido. Scatola da 10 pz. <i>Straight spare blade for stiff cutter. Box of 10 pcs.</i> <i>Lame de rechange droite pour coupoir rigide. Boîte à 10 pcs.</i>
2110358	Forbice speciale per gomma da 8" <i>Shears for rubber 8"</i> <i>Ciseaux spéciaux pour caoutchouc de 8"</i>
2110360	Forbice speciale per gomma da 8" <i>Shears for rubber 8"</i> <i>Ciseaux spéciaux pour caoutchouc de 8"</i>
2110361	Seghetto circolare per crateri Ø 6x220 <i>Tyre hole reamer Ø 6x220</i> <i>Scie passe-partout circulaire pour cratères Ø 6x220</i>
2110363	Tronchesino per fili acciaio da 7 1/2" <i>Steel wire cutting nippers 7 1/2"</i> <i>Tricoises pour fils en acier de 7 1/2"</i>
2110364	Punteruolo a punta conica <i>Awl with conical nail</i> <i>Poinçon à pointe conique</i>
2110365	Punteruolo ad uncino <i>Hooked awl</i> <i>Poinçon en croc</i>
2110366	Punteruolo punta quadra <i>Square headed tip awl</i> <i>Poinçon à pointe carrée</i>
2110368	Scalda coltello con termostato regolabile <i>Knife heater with adjustable thermostat</i> <i>Réchauffeur pour couteaux avec thermostat réglable</i>



2110354



2110355



2110356



2110357



2110360



2110361



2110363



2110364



2110366



2110368

ESTRUSORI PORTATILI
PORTABLE EXTRUDERS
EXTRUDEUSES PORTATIVES



2060245 / 2060245-110V

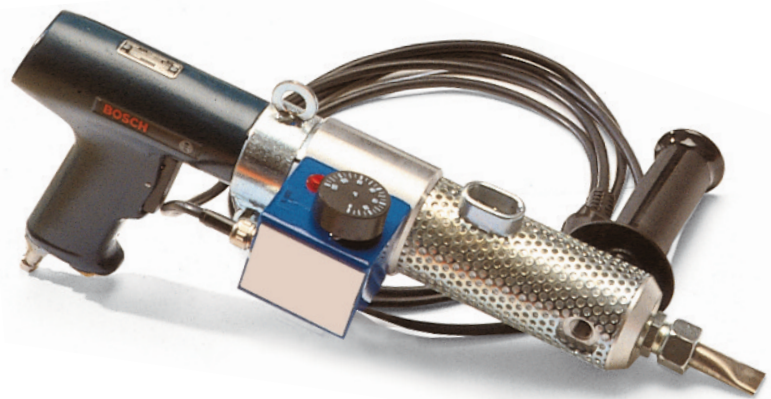

2060245B / 2060245B-110V



2060245E / 2060245E-110V

Estrusori portatili per riempimento dei crateri di riparazione
Portable extruders for filling up cracks
Extrudeuses portatives pour le remplissage des cratères de réparation

Codice Code Code	Modello Model Modèle	Produzione gomma Rubber production Production caoutchouc	Potenza in watt Watt power Puissance en watt	Resistenza elettrica Heating element Résistance électrique	Consumo aria Air consumption Consommation de l'air	Peso kg Weight kg Poids kg	Temp. di estrusione Extruding temperature Température d'extrusion
2060245	MINIEXTRUDER - Ingersoll	18 kg/H	550 watt	350 watt / 220 V	12,5 lt/sec	5	0-120 °C
2060245-110V	MINIEXTRUDER - Ingersoll	18 kg/H	550 watt	350 watt / 110 V	12,5 lt/sec	5	0-120 °C
2060245B	MINIEXTRUDER - Bosch	18 kg/H	550 watt	350 watt / 220 V	12,5 lt/sec	5	0-120 °C
2060245B-110V	MINIEXTRUDER - Bosch	18 kg/H	550 watt	350 watt / 110 V	12,5 lt/sec	5	0-120 °C
2060245E	MINIEXTRUDER - Elettrico	18 kg/H	550 watt	350 watt / 220 V	–	6	0-120 °C
2060245E-110V	MINIEXTRUDER - Elettrico	18 kg/H	550 watt	350 watt / 110 V	–	6	0-120 °C



2060246 / 2060246-110V



2060248 / 2060248-110V



2060247 / 2060247-110V

Estrusori portatili per riempimento dei crateri di riparazione
Portable extruders for filling up cracks
Extrudeuses portatives pour le remplissage des cratères de réparation

Codice Code Code	Modello Model Modèle	Produzione gomma Rubber production Production caoutchouc	Potenza in watt Watt power Puissance en watt	Resistenza elettrica Heating element Résistance électrique	Consumo aria Air consumption Consommation de l'air	Peso kg Weight kg Poids kg	Temp. di estrusione Extruding temperature Température d'extrusion
2060246	MAGNUM	24 kg/H	550 watt	350 watt / 220 V	12,5 lt/sec	6	0-120 °C
2060246-110V	MAGNUM	24 kg/H	550 watt	350 watt / 110 V	12,5 lt/sec	6	0-120 °C
2060247	GIANT	28 kg/H	750 watt	800 watt / 220 V	13,5 lt/sec	6	0-120 °C
2060247-110V	GIANT	28 kg/H	750 watt	800 watt / 110 V	13,5 lt/sec	6	0-120 °C
2060248	EM	40 kg/H	1150 watt	800 watt / 220 V	Elettrico / Electrical / Électrique	13	0-120 °C
2060248-110V	EM	40 kg/H	1150 watt	800 watt / 110 V	Elettrico / Electrical / Électrique	13	0-120 °C

ESTRUSORI PORTATILI
PORTABLE EXTRUDERS
EXTRUDEUSES PORTATIVES



2060250



2060254



2060253 / 2060253-110V



2060255



2060256 / 2060256-110V

2060257 / 2060257-110V

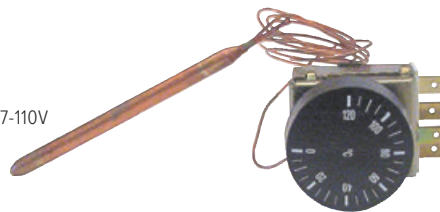

Optionals e parti di ricambio
Optionals and spare parts
Options et pièces de rechange

Codice Code Code	Descrizione Description Description
2060251	Bilanciatore da 5-8.5 kg / Balancer with 5-8.5 kg capacity / Compensateur 5-8.5 kg
2060253	Parte frontale estrusore portatile minixtruder / Front body for minixtruder / Partie frontale pour mini extrudeuse
2060254	Ugello per estrusore portatile / Shaped nozzle for portable minixtruder / Buse pour extrudeuse portative
2060255	Vite per minixtruder portatile / Portable minixtruder screw / Vis pour minixtrudeuse portative
2060256	Resistenza, 220V - 350W per estrusore portatile Heating element, 220V - 350W for portable minixtruder / Résistance électrique, 220V - 350W pour extrudeuse portative
2060256-110V	Resistenza, 110V - 350W per estrusore portatile Heating element, 110V - 350W for portable minixtruder / Résistance électrique, 110V - 350W pour extrudeuse portative
2060257	Termostato per estrusore portatile 220V / Thermostat for portable minixtruder 220V / Thermostat pour extrudeuse portative 220V
2060257-110V	Termostato per estrusore portatile 110V / Thermostat for portable minixtruder 110V / Thermostat pour extrudeuse portative 110V

- Altre parti di ricambio disponibili su richiesta
- Other spare parts available on request
- Autres pièces de rechange disponibles sur demande



2060258

Estrusore tubeless per le riparazioni delle forature da chiodi su pneumatici tubeless
Tubeless extruder for repairing nail holes on tubeless tyres
Extrudeuse tubeless pour les réparations des crevaisons par clous des pneus tubeless

Codice Code Code	Potenza Watt Power Watt Puissance Watt	Peso Weight Poids	Resistenza elettrica Heating element Résistance électrique	Consumo aria Air consumption Consommation air	Temp. di estrusione Extruding temperature Température d'extrusion
2060258	400 W	6 kg	350 W / 220 V	9 lt / sec.	0-120 °C
2060258-110V	400 W	6 kg	350 W / 110 V	9 lt / sec.	0-120 °C



2060259

Gomma per estrusore portatile
Rubber for portable extruder
Caoutchouc pour extrudeuse portative

Codice Code Code	Descrizione Description Description	Diametro Diameter Diamètre
2060259	Rotolo di gomma per estrusore portatile (10 kg) per riparazioni a caldo Roll of rubber for portable extruder (10 kg) for hot repairing Rouleau de caoutchouc pour extrudeuse portative (10 kg) pour réparation à chaud	10 mm 10 mm 10 mm

ACCESSORI E RICAMBI VARI
ACCESSORIES AND SPARE PARTS
ACCESSOIRES ET PIÈCES DE RECHANGE

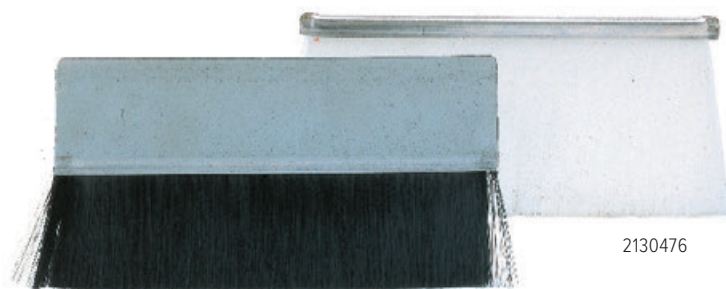

2130476

2130477



2130478

Spazzole parapolverino per raspatrice
Brushes for rubber dust for buffer
Brosses pour poudrette pour râpeuse

Codice Code Code	Descrizione Description Description
2130476	Spazzola parapolverino al metro senza alette Brush for rubber dust in meters without wings Brosse pour poudrette en mètres sans ailettes
2130477	Spazzola parapolverino al metro con alette Brush for rubber dust in meters c/w wings Brosse pour poudrette en mètres avec ailettes
2130478	Spazzola parapolverino al metro senza alette in crine Brush for rubber dust in meters without hair wings Brosse pour poudrette en mètres sans ailettes en crin

Spazzole in nylon
Nylon brushes
Brosses en nylon

Codice Code Code	Dimensioni Sizes Dimensions	Spessore Thickness Épaisseur	Foro Hole Forure
2070268	Ø 120	140/180	Ø 58-53



2070268

Pistole - Guns - Pistolets

Codice Code Code	Descrizione Description Description
2130380	Pistola spruzzapara "AZZ 1,8" Para rubber gun "AZZ 1,8" Pistolet pour caoutchouc "AZZ 1,8"
2130381	Pistola soffiaggio "AZZ" Blowing gun "AZZ" Pistolet de soufflage "AZZ"
2130382	Pistola per Italmatic Matic Airless codice 101105 Gun for Italmatic Matic Airless code 101105 Pistolet pour Matic Airless Italmatic code 101105



Tubi speciali flessibili - Special flexible hoses - Tuyaux spéciaux flexibles

Codice Code Code	Diametro interno Inside diameter Diamètre intérieur
2130384	Ø 70
2130385	Ø 80
2130386	Ø 90
2130387	Ø 100
2130388	Ø 110
2130389	Ø 120
2130390	Ø 130
2130391	Ø 150



Tubi in gomma - Rubber hoses - Tuyaux en caoutchouc

Codice Code Code	Modello Model Modèle	Misura Size Dimension	Tipo Type Type
2130392A	Tubo aria normale per gonfiaggio camere di cottura per presse Normal air hose for curing tubes inflation for presses Tuyau air normal pour gonflage chambres de cuisson pour presses	Ø 8 x 17	ISEO 20
2130393	Tubo aria corazzato per gonfiaggio camere di cottura per presse Armored air hose for curing tubes inflation for presses Tuyau air cuirassé pour gonflage chambres de cuisson pour presses	Ø 8 x 17	SAE 100 R2



Accessori per tubi in gomma

Accessories for rubber hoses - Accessoires pour tuyaux en caoutchouc

Codice Code Code	Descrizione Description Description
2130395	Attacco rapido 1/4" femmina Quick connector 1/4" female - Connecteur rapide 1/4" femelle
2130396	Attacco rapido 1/4" maschio Quick connector 1/4" male - Connecteur rapide 1/4" mâle
2130397	Portagomma per tubo da 17 mm Rubber support for hose 17 mm - Support du caoutchouc pour tuyau 17 mm
2130398	Prolunga a vite tipo "L" da mm 8 Screw extension type "L" 8 mm - Rallonge à vis type "L" 8 mm

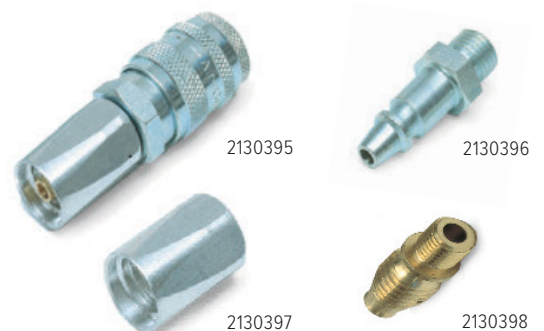

ACCESSORI E RICAMBI VARI
ACCESSORIES AND SPARE PARTS
ACCESSOIRES ET PIÈCES DE RECHANGE

Tubi teflon / Teflon hoses / Tuyaux en teflon

Codice Code Code	Descrizione Description Description	Tipo Type Type	Misura Size Dimension	Lunghezza Length Longueur
2130400	Per presse completo di raccordo maschio o femmina <i>For presses c/w male or female coupler</i> <i>Pour presses complet de raccord mâle ou femelle</i>	W3	1 / 4"	on req.
2130401	Per presse completo di raccordo maschio o femmina <i>For presses c/w male or female coupler</i> <i>Pour presses complet de raccord mâle ou femelle</i>	W4	3 / 8"	on req.
2130402	Per presse completo di raccordo maschio o femmina <i>For presses c/w male or female coupler</i> <i>Pour presses complet de raccord mâle ou femelle</i>	W6	1 / 2"	on req.
2130403A	Per autoclave / <i>For autoclave / Pour autoclave</i>	–	1 / 4"	1200 mm
2130403B	Per autoclave / <i>For autoclave / Pour autoclave</i>	–	1 / 4"	1400 mm
2130403C	Per autoclave / <i>For autoclave / Pour autoclave</i>	–	1 / 4"	1600 mm
2130403D	Per autoclave / <i>For autoclave / Pour autoclave</i>	–	1 / 4"	2000 mm
2130403E	Per autoclave / <i>For autoclave / Pour autoclave</i>	–	1 / 4"	2400 mm
2130403F	Per autoclave / <i>For autoclave / Pour autoclave</i>	–	1 / 4"	2800 mm



2130400

Tubi teflon con molla di protezione
Teflon hoses with protection spring / Tuyaux en teflon avec ressort de protection

Codice Code Code	Descrizione Description Description	Tipo Type Type	Misura Size Dimension	Lunghezza Length Longueur
2130400R	Per presse completo di raccordo maschio o femmina <i>For presses c/w male or female coupler</i> <i>Pour presses complet de raccord mâle ou femelle</i>	W3	1 / 4"	on req.
2130401R	Per presse completo di raccordo maschio o femmina <i>For presses c/w male or female coupler</i> <i>Pour presses complet de raccord mâle ou femelle</i>	W4	3 / 8"	on req.
2130402R	Per presse completo di raccordo maschio o femmina <i>For presses c/w male or female coupler</i> <i>Pour presses complet de raccord mâle ou femelle</i>	W6	1 / 2"	on req.
2130403AR	Per autoclave / <i>For autoclave / Pour autoclave</i>	–	1 / 4"	1200 mm
2130403BR	Per autoclave / <i>For autoclave / Pour autoclave</i>	–	1 / 4"	1400 mm
2130403CR	Per autoclave / <i>For autoclave / Pour autoclave</i>	–	1 / 4"	1600 mm
2130403DR	Per autoclave / <i>For autoclave / Pour autoclave</i>	–	1 / 4"	2000 mm
2130403ER	Per autoclave / <i>For autoclave / Pour autoclave</i>	–	1 / 4"	2400 mm
2130403FR	Per autoclave / <i>For autoclave / Pour autoclave</i>	–	1 / 4"	2800 mm



2130400R



2130404



2130404A



2130404E



2130404F

Serie valvole per camere di cottura per pressa
Valves kit for curing tubes for press
Série de valves pour chambres de cuisson pour presse

Codice Code Code	Descrizione Description Description
2130404	Valvola in ottone tipo B diam. 12/8 speciale per U-Tubes <i>Brass valve type B 12/8 special for U-Tubes</i> <i>Valve en laiton type B diam. 12/8 spéciale pour U-Tubes</i>
2130404A	Valvola in ottone tipo A 1/4" <i>Brass valve type A 1/4" / Valve en laiton type A 1/4"</i>
2130404E	Piastrella grande per camere di cottura <i>Large protection diaphragm for curing tubes/ Protection grande pour chambres de cuisson</i>
2130404F	Piastrella piccola per camere di cottura <i>Small protection diaphragm for curing tubes / Protection petite pour chambres de cuisson</i>

- Vengono combinati con articoli codice 2130404A e codice 2130404E o 2130404F.

- They are combined with items code 2130404A and code 2130404E or 2130404F.

- Ils sont combinés avec les articles code 2130404A et code 2130404E ou 2130404F.

Kit valvole per envelopes e camere per autoclavi
Valves kit for envelopes and tubes for autoclaves
Kit de valves pour envelopes et chambres pour autoclaves

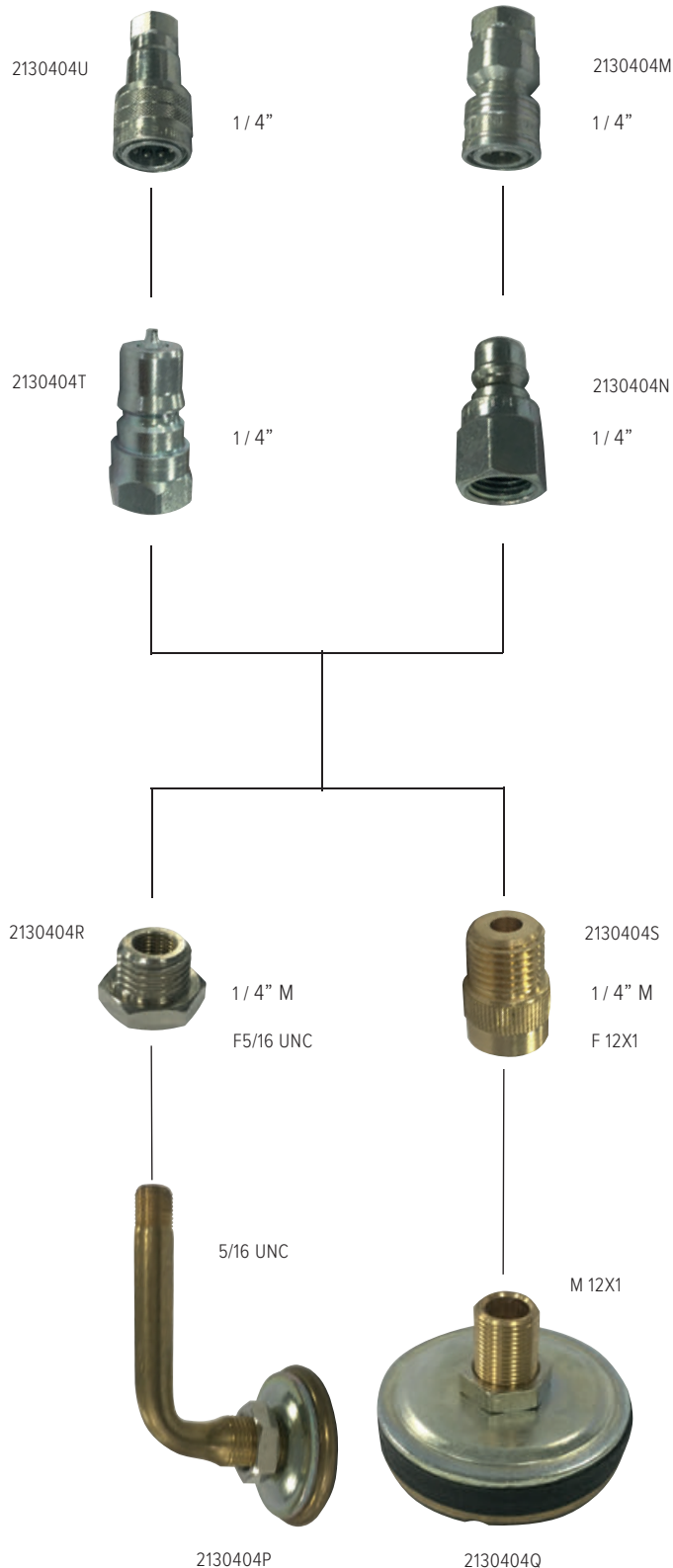

Codice / Code / Code	Descrizione / Description / Description
2130404M	Attacco aria autoclave per camere d'aria per utilizzo tecnologia con cerchi <i>Autoclave air connector for air tubes to be used with rims technology</i> <i>Connecteur air autoclave pour chambres à air pour technologie avec jantes</i>

Codice / Code / Code	Descrizione / Description / Description
2130404N	Nipple aria autoclave per camere d'aria per utilizzo tecnologia con cerchi <i>Autoclave air nipple for air tubes to be used with rims technology</i> <i>Nipple air autoclave pour chambres à air pour technologie avec jantes</i>

Codice / Code / Code	Descrizione / Description / Description
2130404P	Valvola envelope tipo "1" <i>Valve for envelope type "1"</i> <i>Valve pour envelope type "1"</i>

Codice / Code / Code	Descrizione / Description / Description
2130404Q	Valvola envelope tipo "2" - Filetto 482-26 <i>Valve for envelope type "2" - Tread 482-26</i> <i>Valve pour envelope type "2" - Fil 482-26</i>

Codice / Code / Code	Descrizione / Description / Description
2130404R	Riduttore 5/16" femmina 1/4" maschio <i>Reducer 5/16" female 1/4" male</i> <i>Réducteur 5/16" femelle 1/4" mâle</i>

Codice / Code / Code	Descrizione / Description / Description
2130404S	Riduttore 482 - 26 - R 1/4" <i>Reducer 482 - 26 - R 1/4"</i> <i>Réducteur 482 - 26 - R 1/4"</i>

Codice / Code / Code	Descrizione / Description / Description
2130404T	Nipple aria per envelopes per autoclavi <i>Air nipple for envelopes for autoclaves</i> <i>Nipple air pour envelopes pour autoclaves</i>

Codice / Code / Code	Descrizione / Description / Description
2130404U	Attacco aria per envelopes per autoclavi <i>Air connector for envelopes for autoclaves</i> <i>Connecteur air pour envelopes pour autoclaves</i>

ACCESSORI E RICAMBI VARI
ACCESSORIES AND SPARE PARTS
ACCESSOIRES ET PIÈCES DE RECHANGE

Attacchi - Connectors - Connecteurs

Codice Code Code	Modello Model Modèle
2130405	Attacco vapore femmina da 1/2" in ottone <i>Brass female steam connector 1/2"</i> <i>Connecteur vapeur femelle 1/2" en laiton</i>
2130406	Attacco aria 1 canale da 1/4" femmina <i>One way air connector - 1/4" female</i> <i>Connecteur air à 1 voie - 1/4" femelle</i>
2130408	Attacco rapido aria tipo "L" da 3/8" femmina <i>Air quick connector type "L" 3/8" female</i> <i>Connecteur rapide air type "L" 3/8" femelle</i>
2130409	Attacco rapido aria da 1/4" tipo RTS <i>Air quick connector 1/4" type RTS</i> <i>Connecteur rapide air 1/4" type RTS</i>
2130410	Portagomma da 23 mm <i>Rubber support 23 mm / Support du caoutchouc 23 mm</i>



2130405



2130406



2130408



2130410

Attacchi - Connectors - Connecteurs

Codice Code Code	Modello Model Modèle
2130411	Nipple vapore maschio in ottone da 1/2" <i>Brass steam male nipple 1/2"</i> <i>Nipple vapeur mâle 1/2" en laiton</i>
2130412	Nipple vapore femmina in ottone da 1/2" <i>Brass steam female nipple 1/2"</i> <i>Nipple vapeur femelle 1/2" en laiton</i>
2130413	Nipple aria tipo "L" 3/8" maschio <i>Air "L" nipple - 3/8" male</i> <i>Nipple air à "L" - 3/8" mâle</i>
2130414	Nipple aria tipo "L" 1/4" femmina <i>Air "L" nipple - 1/4" female</i> <i>Nipple air à "L" - 1/4" femelle</i>
2130415	Nipple aria tipo RTS da 1/4" femmina <i>Air nipple type RTS - 1/4" female</i> <i>Nipple air type RTS 1/4" femelle</i>
2130416	Nipple aria in ottone 1 canale da 1/4" <i>One way brass air nipple - 1/4"</i> <i>Nipple air en laiton à 1 voie - 1/4"</i>
2130417	Nipple aria in ottone 1 canale filetto valvola <i>One way brass air nipple - valve thread</i> <i>Nipple air en laiton à 1 voie - filet valve</i>
2130418	Nipple aria in ottone da 1/4" codulo per tubo diam. 8 mm <i>Brass air nipple 1/4" spigot for tube diam. 8 mm</i> <i>Nipple air en laiton 1/4" queue pour tube diam. 8 mm</i>



2130411



2130412



2130413



2130416



2130417



2130418

Raccordi - Couplers - Raccords

Codice Code Code	Modello Model Modèle
2130420	Prolunga a vite in ottone tipo "L" da mm 12 per attacco 3/8" <i>Brass screw extension type "L" 12 mm for connector 3/8"</i> <i>Rallonge à vis en laiton type "L" 12 mm pour connecteur 3/8"</i>
2130421	Raccordo maschio da 1/4" codulo a vite 7 mm <i>Male coupler 1/4" screw spigot 7 mm</i> <i>Raccord mâle 1/4" queue à vis 7 mm</i>



2130420



2130421

Guarnizioni
Gaskets
Joints

Codice Code Code	Modello Model Modèle
2130424	Guarnizione da 1/2" per attacco vapore nera <i>Black gasket 1/2" for steam connector</i> <i>Joint noir 1/2" pour connecteur vapeur</i>
2130425	Guarnizione aria tipo "A" al silicone <i>Air silicone gasket type "A"</i> <i>Joint à la silicone air type "A"</i>
2130426	Guarnizione aria tipo "A" nera <i>Black air gasket type "A"</i> <i>Joint air noir type "A"</i>
2130427	Guarnizione aria tipo "B" al silicone <i>Air silicone gasket type "B"</i> <i>Joint à la silicone air type "B"</i>
2130428	Guarnizione aria tipo "B" nera <i>Black air gasket type "B"</i> <i>Joint air noir type "B"</i>
2130429	Guarnizione aria tipo "L" da 1/4" <i>Air gasket type "L" 1/4"</i> <i>Joint air type "L" 1/4"</i>
2130430	Guarnizione aria tipo "L" da 3/8" <i>Air gasket type "L" 3/8"</i> <i>Joint air type "L" 3/8"</i>



2130424



2130425



2130426



2130427



2130428



2130429

Rubinetti
Taps
Robinets

Codice Code Code	Modello Model Modèle	Filettatura interna Inside thread Filet intérieur
2130432	Rubinetto a sfera <i>Ball tap / Robinet à billes</i>	Ø 1/4"
2130433	Rubinetto a sfera <i>Ball tap / Robinet à billes</i>	Ø 3/8"
2130434	Rubinetto a sfera <i>Ball tap / Robinet à billes</i>	Ø 1/2"
2130435	Rubinetto a sfera <i>Ball tap / Robinet à billes</i>	Ø 3/4"
2130436	Rubinetto a sfera <i>Ball tap / Robinet à billes</i>	Ø 1"



2130434



2130432

Calibri
Gauges
Calibres

Codice Code Code	Modello Model Modèle
2130440	Calibro digitale mm 150 <i>Digital gauge mm 150</i> <i>Calibre digital mm 150</i>
2130440B	Calibro meccanico mm 150 <i>Mechanical gauge mm 150</i> <i>Calibre mécanique mm 150</i>



2130440



2130440B

ACCESSORI E RICAMBI VARI
ACCESSORIES AND SPARE PARTS
ACCESSOIRES ET PIÈCES DE RECHANGE

Metri decimali
Decimal meters
Mètres décimaux

Codice Code Code	Lunghezza in metri Length in meters Longueur en mètres	Materiale Material Matériel
2130442	10	Fibra di vetro / Fiber glass / Fibre de verre
2130443	10	Acciaio rivestito in nylon Nylon coated steel Acier habillé en nylon
2130446	20	Acciaio smaltato / Enameled steel / Acier émaillé



2130442



2130446

Termometri
Thermometers
Thermomètres

Codice Code Code	Modello Model Modèle	Scala Scale Echelle
2130447	Termometro con microprocessore a tenuta stagna - precisione $\pm 0,5^{\circ}\text{C}$ completo di termocoppia per superfici Thermometer c/w microprocessor with water seal - precision $\pm 0,5^{\circ}\text{C}$ c/w thermocouple for surfaces Thermomètre avec microprocesseur à étanche d'eau - précision $\pm 0,5^{\circ}\text{C}$ complet de thermocouple pour surfaces	- 50°C + 850°C
2130448	Sonda termocoppia per superfici per codice 2130447 Thermocouple probe for surfaces for code 2130447 Sonde thermocouple pour surfaces pour code 2130447	
2130448C	Termometro ad infrarossi Infra-red rays thermometer Thermomètre rayons infrarouges	- 50°C + 750°C



2130447



2130448C



2130448

Durometro per gomma
Hardness measuring device for rubber
Mesureur de dureté pour caoutchouc

Codice Code Code	Shores - A Shores - A Shores - A	Custodia Sheath Étui
2130449	0 ÷ 100	Legno / Wood / Bois



2130449

Fasce in gomma nera Italmatic per mandrini a 8 settori standard
Italmatic black rubber bands for standard chucks in 8 segments
Bandes en caoutchouc noir Italmatic pour mandrins standard en 8 secteurs

Codice Code Code	Dimensioni Sizes Dimensions	Tipo mandrino Type of chuck Type de mandrin
2130455	10" x 147	10/12" x 140
2130456	12-14" x 147	12/14" x 140
2130457	13-15" x 187	13/15" x 180
2130458	14-16" x 147	14/16" x 140
2130458S	16-18" x 203	16/18" x 190
2130459	17,5-19,5" x 228	17,5-19,5" x 220
2130460	19,5-22,5" x 228	19,5-22,5" x 220
2130461	22,5-24,5" x 262	22,5-24,5" x 250
2130462	Attrezzo per il montaggio fasce mandrino Tool to mount chuck rubber bands Outil pour le montage des bandes en caoutchouc pour mandrin	

- Su richiesta, fasce di qualsiasi tipo
- Upon request, rubber bands of any size
- Sur demande, bandes en caoutchouc de toutes dimensions

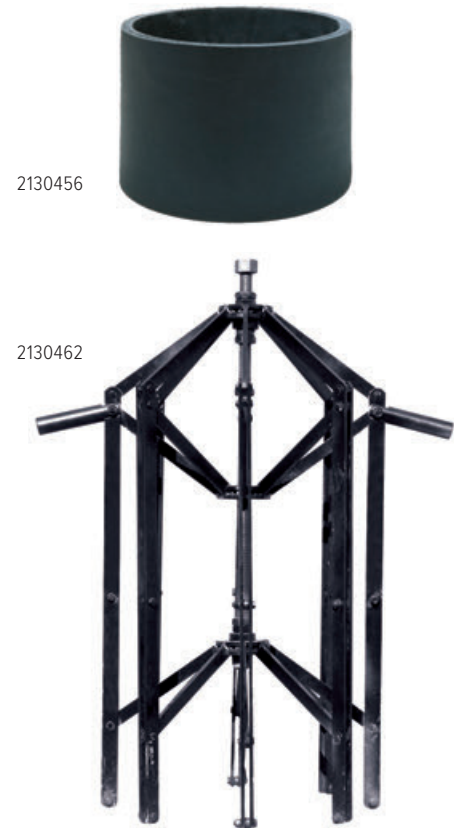

Silicone per presse
Silicone for presses
Silicone pour presses

Codice Code Code	Descrizione Description Description
2130463	Silicone spray Spray silicone Silicone en vaporisateur
2130465	Silicone liquido concentrato - contenitore kg 60 Concentrated liquid silicone - container capacity 60 kg Silicone liquide concentrée - récipient à 60 kg
2130466	Nebulizzatore per silicone con serbatoio carrellato da 24 lt completo di accessori Nebulizer for silicone with tank on trolley capacity 24 lt complete with accessories Atomiseur pour silicone avec réservoir sur chariot capacité 24 lt complet d'accessoires
2130466A	Nebulizzatore in acciaio inox per silicone con serbatoio carrellato da 24lt completo di accessori Stainless steel nebulizer for silicone with tank on trolley capacity 24lt complete with accessories Atomiseur inox pour silicone avec reservoir sur chariot capacité 24lt complet d'accessoires
2130467	Lancia speciale spruzza silicone per codice 2130466 Special nozzle for silicone spraying for code 2130466 Lance spéciale pour vaporiser la silicone pour code 2130466
2130467A	Lancia speciale inox spruzza silicone per codice 2130466A Special stainless steel nozzle for silicone spraying for code 2130466A Lance spéciale inox pour vaporiser la silicone pour code 2130466A



ACCESSORI E RICAMBI VARI
ACCESSORIES AND SPARE PARTS
ACCESSOIRES ET PIÈCES DE RECHANGE



2130475A

Guarnizioni per autoclavi
Seals for autoclaves
Joints pour autoclaves

Codice Code Code	Descrizione Description Description	Spessore Thickness Épaisseur	Tipo autoclave Autoclave model Modèle autoclave
2130470B	Guarnizione anello chiuso / Closed ring seal / Joint à anneau fermé	15 mm	AI Ø 1000
2130470D	Guarnizione anello chiuso / Closed ring seal / Joint à anneau fermé	13 mm	AI Ø 1000
2130470F	Guarnizione anello chiuso / Closed ring seal / Joint à anneau fermé	15 mm	AI Ø 1050
2130470H	Guarnizione anello chiuso doppio labbro Closed ring seal with double lip / Joint à anneau fermé à double lèvre	15 mm	AI Ø 1050
2130470K	Guarnizione anello chiuso / Closed ring seal / Joint à anneau fermé	15 mm	AI Ø 1300
2130471B	Guarnizione anello chiuso / Closed ring seal / Joint à anneau fermé	15 mm	AI Ø 1500
2130471D	Guarnizione anello chiuso / Closed ring seal / Joint à anneau fermé	13 mm	AI Ø 1500
2130472B	Guarnizione anello chiuso / Closed ring seal / Joint à anneau fermé	15 mm	AI Ø 1700
2130472C	Guarnizione anello chiuso doppio labbro / Closed ring seal with double lip / Joint à anneau fermé à double lèvre	15 mm	AI Ø 1700
2130472D	Guarnizione anello chiuso / Closed ring seal / Joint à anneau fermé	15 mm	AI Ø 2100
2130472F	Guarnizione anello chiuso doppio labbro Closed ring seal with double lip / Joint à anneau fermé à double lèvre	15 mm	AI Ø 2100
2130472H	Guarnizione anello chiuso doppio labbro Closed ring seal with double lip / Joint à anneau fermé à double lèvre	17 mm	AI Ø 2100
2130472K	Guarnizione anello chiuso / Closed ring seal / Joint à anneau fermé	15 mm	AI Ø 2300
2130472N	Guarnizione anello chiuso / Closed ring seal / Joint à anneau fermé	15 mm	AI Ø 2600
2130472Q	Guarnizione anello chiuso doppio labbro Closed ring seal with double lip / Joint à anneau fermé à double lèvre	15 mm	AI Ø 2600
2130472S	Guarnizione anello chiuso / Closed ring seal / Joint à anneau fermé	15 mm	AI Ø 2800
2130473B	Guarnizione anello chiuso / Closed ring seal / Joint à anneau fermé	15 mm	AI Ø 3000
2130473D	Guarnizione anello chiuso doppio labbro Closed ring seal with double lip / Joint à anneau fermé à double lèvre	15 mm	AI Ø 3000
2130473G	Guarnizione anello chiuso doppio labbro Closed ring seal with double lip / Joint à anneau fermé à double lèvre	15 mm	AI Ø 3300
2130473L	Guarnizione anello chiuso profilo speciale Closed ring seal with special profile / Joint à anneau fermé profil spécial	–	AI Ø 2200
2130473F	Guarnizione anello chiuso / Closed ring seal / Joint à anneau fermé	15 mm	AI Ø 3300
2130473H	Guarnizione anello chiuso profilo speciale Closed ring seal special profile / Joint à anneau fermé profil spécial	–	AI Ø 3800
2130473K	Guarnizione anello chiuso profilo speciale Closed ring seal special profile / Joint à anneau fermé profil spécial	–	AI Ø 4200
2130474A	Rotolo da 20 m Roll of 20 m / Rouleau à 20 m	15 mm	AI Ø 3300-3000 2600-2100-1050
2130474C	Rotolo da 20 m doppio labbro Roll of 20 m with double lip / Rouleau à 20 m à double lèvre	15 mm	AI Ø 3300-3000 2600-2100-1050
2130474E	Rotolo da 20 m / Roll of 20 m / Rouleau à 20 m	13 mm	AI Ø 1000-1500
2130474G	Rotolo da 20 m doppio labbro Roll of 20 m with double lip / Rouleau à 20 m à double lèvre	17 mm	AI Ø 2100
2130474J	Rotolo da 25 m profilo speciale Roll of 25 m special profile / Rouleau à 25 m profil spécial	–	AI Ø 3800
2130474M	Rotolo da 27 m profilo speciale Roll of 27 m special profile / Rouleau à 27 m profil spécial	–	AI Ø 4200



2130475C



2130475G



2130475H



2130475K

Altri accessori autoclavi e cilindri
Other accessories for autoclaves and rollers
Autres accessoires pour autoclaves et cylindres

Codice Code Code	Descrizione Description Description
2130475C	Colla al silicone in tubetto da g 100 per incollare le estremità della guarnizione Silicone glue in g 100 tube for sticking together the gasket ends Colle à la silicone en tube de 100 g pour agglutiner les extrémités du joint
2130475E	Grasso per lubrificazione cuscinetti motori pressurizzati, kg 1 Grease for pressurized motor bearings lubrication, kg 1 Graisse pour lubrifier les roulements des moteurs pressurisés, kg 1
2130475F	Grasso per lubrificazione denti rotazione porta, kg 1 Grease for door rotation teeth lubrication, kg 1 Graisse pour lubrifier les dents rotation porte, kg 1
2130475G	Grasso per lubrificazione delle guarnizioni kg 1 Grease for gaskets lubrication kg 1 Graisse pour lubrifier les joints kg 1
2130475H	Pennini per registratore (colori disponibili: rosso/blu/verde) Pens for recorder (available colours: red/blue/green) Petits stylos pour enregistreur (couleurs disponibles: rouge/bleu/vert)
2130475K	Set carta per registratore a display 100 mm x 30 m Paper set for display recorder 100 mm x 30 m Jeu de papier pour enregistreur avec display 100 mm x 30 m
2130475L	Diagrammi per registratore (confezione 100 pz.) - circolare Diagrams for recorder (box of 100 pcs.) - round Diagrammes pour enregistreur (conditionnement à 100 pcs.) - ronds
2130475M	Vernice antiruggine speciale per autoclavi alluminio alta temperatura - contenitore 5 lt Rustproof special paint for high temperature aluminium autoclaves - container 5 lt Peinture antirouille spéciale pour autoclaves aluminium hautes températures - récipient 5 lt
2130475S	Film per rivestimento cilindri in polipropilene (1 kg) 80 mm Film for rollers wrapping (1 kg) 80 mm Film pour habillage cylindres (1 kg) 80 mm
2130475T	Benda per rivestimento cilindri in film plastico 70 mm - 1 metro Wrapping tape for rollers 70 mm - 1 meter Bandage pour habillage cylindres 70 mm - 1 mètre
2130475TW	Benda per rivestimento cilindri in tessuto di nylon 120 mm - 1 metro Nylon tissue wrapping tape for rollers 120 mm - 1 meter Bandage de tissu de nylon pour habillage cylindres 120 mm - 1 mètre
2130475U	Carta per rivestimento cilindri (sottostrato per codice 2130475T) - 1 kg Paper for rollers wrapping (underlying strata for code 2130475T) - 1 kg Papier pour habillage cylindres (sous-couche pour code 2130475T) - 1 kg
2130475Z	Guarnizione per motore autoclave (tutti i tipi di autoclave) Gasket for autoclave motor (all models of autoclave) Joint pour moteur autoclave (tous modèles d'autoclave)

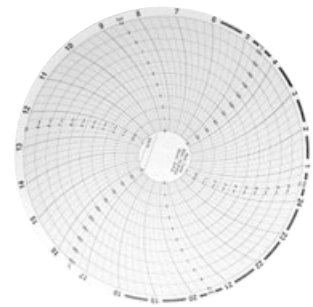

2130475L



2130475S



2130475T



2130475Z

ACCESSORI E RICAMBI VARI
ACCESSORIES AND SPARE PARTS
ACCESSOIRES ET PIÈCES DE RECHANGE

Graffatrice pneumatica
Pneumatic stapler
Agrafeuse pneumatique

Codice Code Code	Descrizione Description Description	Confezione Box Conditionnement
2130478	Graffatrice pneumatica per prestampato 8/14 <i>Pneumatic stapler for precured tread 8/14</i> <i>Agrafeuse pneumatique pour la bande de roulement 8/14</i>	–
2130479	Punti metallici per graffatrice 8/6 - 6x12 da 1/4" <i>Metal staples for stapler 8/6 - 6x12 - 1/4"</i> <i>Points métalliques pour agrafeuse 8/6 - 6x12 - 1/4"</i>	10.000 pcs.
2130480	Punti metallici per graffatrice 8/8 - 8x12 da 5/16" <i>Metal staples for stapler 8/8 - 8x12 - 5/16"</i> <i>Points métalliques pour agrafeuse 8/8 - 8x12 - 5/16"</i>	10.000 pcs.



Gessi Sisa
Sisa chalks
Craies Sisa

Codice Code Code	Descrizione Description Description	Colore Colour Couleur	Lunghezza Length Longueur	Ø mm Ø mm Ø mm	Pz. / scatola Pcs. / box Pcs. / boîte
3080019B	Gessi SISA <i>Sisa chalks / Craies Sisa</i>	Bianchi <i>White / Blanche</i>	9 cm	17,5	12
3080019G	Gessi SISA <i>Sisa chalks / Craies Sisa</i>	Gialli <i>yellow / jaunes</i>	9 cm	17,5	12
3080019R	Gessi Sisa <i>Sisa Chalks / Craies Sisa</i>	Rosso <i>Red / Rouge</i>	9 cm	17,5	12
3080019S	Gessi Sisa <i>Sisa Chalks / Craies Sisa</i>	Rosa <i>Pink / Rose</i>	9 cm	17,5	12
3080019V	Gessi Sisa <i>Sisa Chalks / Craies Sisa</i>	Verde <i>Green / Verte</i>	9 cm	17,5	12
3080019H	Porta gessi <i>Chalks holder / Porte Craie</i>	–	–	17,5	1



Gessi Italmatic alte prestazioni
Italmatic chalks high performances
Craies Italmatic high performances

Codice Code Code	Descrizione Description Description	Colore Colour Couleur	Lunghezza Length Longueur	Ø mm Ø mm Ø mm	Pz. / scatola Pcs. / box Pcs. / boîte
3080019B-IT	Gessi Italmatic <i>Italmatic chalks / Craies Italmatic</i>	Bianchi <i>White / Blanche</i>	9 cm	17,5	12
3080019G-IT	Gessi Italmatic <i>Italmatic chalks / Craies Italmatic</i>	Gialli <i>Yellow / Jaunes</i>	9 cm	17,5	12
3080019S-IT	Gessi Italmatic <i>Italmatic Chalks / Craies Italmatic</i>	Rosa <i>Pink / Rose</i>	9 cm	17,5	12
3080020-IT	Gessi Italmatic <i>Italmatic chalks / Craies Italmatic</i>	Bianchi <i>White / Blanche</i>	12 cm	12,5	12
3080021G-IT	Gessi Italmatic <i>Italmatic chalks / Craies Italmatic</i>	Gialli <i>Yellow / Jaunes</i>	12 cm	12,5	12
3080021S-IT	Gessi Italmatic <i>Italmatic Chalks / Craies Italmatic</i>	Rosa <i>Pink / Rose</i>	12 cm	12,5	12
3080018-IT	Porta gessi <i>Chalks holder / Porte Craie</i>	–	–	17,5	–
3080018S-IT	Porta gessi <i>Chalks holder / Porte Craie</i>	–	–	12,5	–



3080018S-IT

3080018-IT



3080019G-IT

3080019B-IT

ACCESSORI ANTINFORTUNISTICA
ACCESSORIES FOR INDUSTRIAL ACCIDENTS PREVENTION
ACCESSOIRES POUR LA PRÉVENTION DES ACCIDENTS



2140477

Codice / Code / Code	Descrizione / Description / Description
2140477	Guanti bianchi da lavoro in pelle fiore bovina White work gloves in cow soft leather Gants blancs de travail en peau bovine souple



2140481

Freq.	H	M	L	SNR
Attenuaz. in DB Attenuation in DB Atténuation en DB	31	21	12	24

Codice / Code / Code	Descrizione / Description / Description
2140481	Cuffia antirumore g 130 Noise protecting cap g 130 Coiffe antibruit g 130



2140477S

Ideali per ricostruzione pneumatici
Ideal for tyre retreading
Idéaux pour rechapage pneus

Codice / Code / Code	Descrizione / Description / Description
2140477S	Guanti grigi da lavoro in crosta 7cm Grey work gloves in leather 7 cm Gants gris de travail en peau 7 cm



2140482

Freq.	H	M	L	SNR
Attenuaz. in DB Attenuation in DB Atténuation en DB	30	24	22	28

Codice / Code / Code	Descrizione / Description / Description
2140482	Tappi antirumore (1 paio) Noise protecting plugs (1 pair) Bouchons antibruit (1 paire)



2140478

Codice / Code / Code	Descrizione / Description / Description
2140478	Guanti per alte temperature a manichetta High temperatures gloves with sleeve Gants pour hautes températures avec manche



2140483



2140484

Codice / Code / Code	Descrizione / Description / Description
2140483	Occhiali neutri a stanghetta Neutral spectacles with arm Lunettes neutres avec branches
2140484	Lenti temperate di ricambio per occhiali Tempered spare lens for spectacles Verres trempés de rechange pour lunettes

Per polveri a bassa nocività
For low harmfulness dusts
Pour poudres à basse nocivité



2140479



2140480

Per polveri ad alta nocività
For high harmfulness dusts
Pour poudres à haute nocivité

Codice / Code / Code	Descrizione / Description / Description
2140479	Maschera antipolvere 3M Dust protecting mask 3M Masque antipoudre 3M
2140480	Maschera con filtro in carbone 3M Mask with coal filter 3M Masque avec filtre en charbon 3M



2140485 / 2140485A

Codice / Code / Code	Descrizione / Description / Description
2140485	Schermo in policarbonato antiurto Shockproof polycarbonate shield Écran antichoc en polycarbonate
2140485A	Caschetto ABS blu con regolazione a cricchetto ABS blue helmet with jack adjustment Casque en ABS bleu avec réglage à cric

MARCATORE ELETTRICO
ELECTRIC MARKER
DISPOSITIF ÉLECTRIQUE POUR MARQUER



2130450S / 2130450

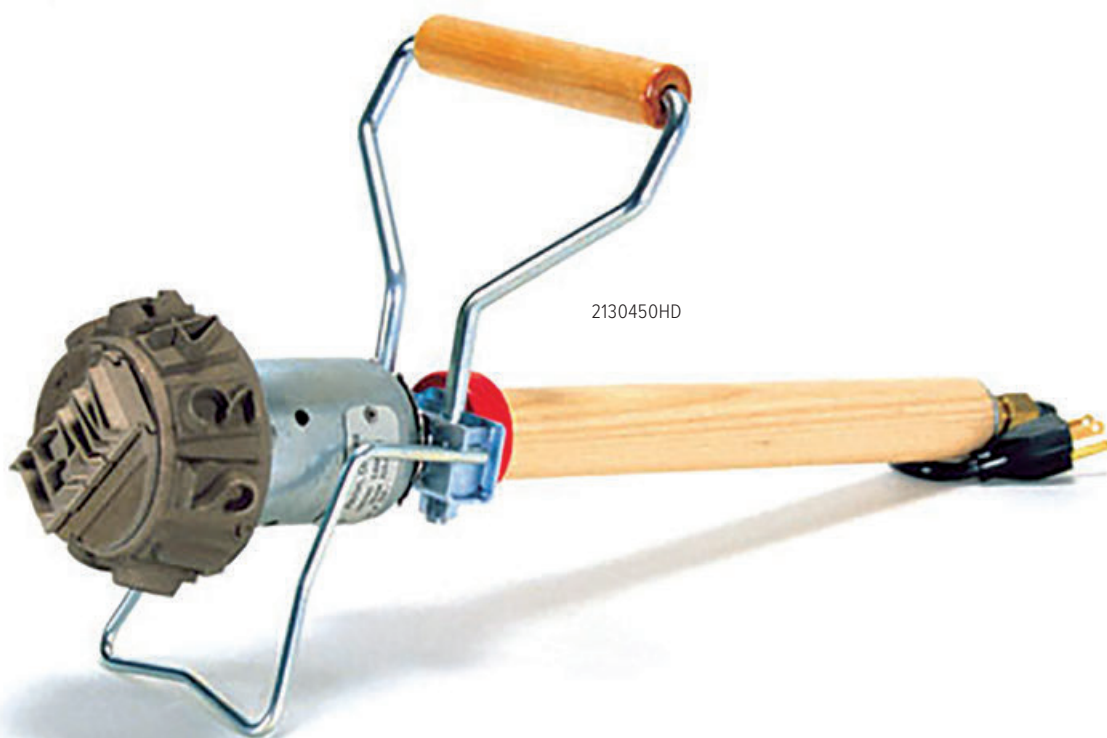

2130450HD

Marcatore elettrico
Electric marker
Dispositif électrique pour marquer

Codice Code Code	Descrizione Description Description	Watt
2130450	Marcatore elettrico volt 230 completo di compositoio 70x30mm, max 6 caratteri Electric marker volt 230 complete with composing stick 70x30mm, max 6 type Dispositif électrique pour marquer volt 230 avec composteur 70x30mm, max 6 caractères	300
2130450S	Marcatore elettrico 240 V, 90x40, max 9 caratteri Electric marker 240 V, 90x40, max 9 type Dispositif électrique pour marquer 240 V, 90x40, max 9 caractères	400
2130450HD	Marcatore elettrico 240 V testa troncoconica Electric marker 240 V truncated conical head Dispositif électrique pour marquer 240 V tête tronconique	1000



2130451D



2130451HDC

Carattere alfanumerico
Alphanumerical type
Caractere alpha-numerique

Codice Code Code	Descrizione Description Description
2130451D	Carattere alfanumerico per marcatore h 12 mm, per 2130450-2130450S <i>Alpha-numerical type for marker h 12 mm, for 2130450-2130450S</i> <i>Caractère alpha-numérique pour dispositif électrique pour marquer h 12 mm, pour 2130450-2130450S</i>
2130451HDC	Carattere alfanumerico per marcatore h 12 mm, per 2130450-2130450S <i>Alpha-numerical type for marker h 12 mm, for 2130450-2130450S</i> <i>Caractère alpha-numérique pour dispositif électrique pour marquer h 12 mm, pour 2130450-2130450S</i>

Ricambi per marcatore elettrico
Electric marker spare parts
Recharge pour marquer électrique

Codice Code Code	Descrizione Description Description
2130451	Stampo in ottone con diciture fisse <i>Brass mould with fix engravings</i> <i>Moule en laiton avec gravures fixes</i>
2130451B	Stampo in ottone per marcatore con logo aziendale <i>Brass mould for marker with company's logo</i> <i>Moule en laiton pour dispositif électrique pour marquer avec logo de la société</i>
2130451D	Carattere alfanumerico per marcatore h 12 mm, per 2130450-2130450H <i>Alpha-numerical type for marker h 12 mm, for 2130450-2130450H</i> <i>Caractère alpha-numérique pour dispositif électrique pour marquer h 12 mm, pour 2130450-2130450H</i>
2130452HD	Resistenza per 2130450HD <i>Heating unit for 2130450HD</i> <i>Set resistance pour 2130450HD</i>
2130452	Set resistenza per marcatore (2 elementi da 150W/cad.) completi di isolamento <i>Set heating element for marker (2 elements of 150W/each) complete with insulation</i> <i>Set résistance pour dispositif pour marquer (2 elements de 150W/chacun) complet d'isolation</i>
2130452B	Set di isolanti <i>Set of insulating plates</i> <i>Jeu de plaques isolantes</i>
2130452D	Spessori <i>Shims</i> <i>Épaisseurs</i>
2130453	Smarcatore completo di lama <i>Erasing device complete with blade</i> <i>Outil defaceur complet de lame</i>
2130454	Lama di ricambio <i>Spare blade</i> <i>Lame de rechange</i>

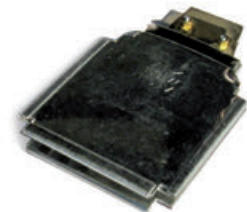

2130452



2130452D



2130452B



2130453

Caratteri alfanumerici di altre misure sono disponibili su richiesta (mm 6 / 8 / 10 / 15 / 20). Per caratteri di misure differenti, è necessario richiedere una versione specifica del marcatore con un adeguato compositoio.
Alphanumeric types of other sizes are available on request (mm 6 / 8 / 10 / 15 / 20). For types of different sizes, a specific version of the marker will have to be requested with a suitable composing slot.
Caractères alphanumériques d'autres dimensions sont disponibles sur demande (mm 6 / 8 / 10 / 15 / 20). Pour caractères de dimensions différentes, il est nécessaire de demander une version spécifique du marqueur avec un composteur indiqué.

RIGATORI E LAMETTE

GROOVERS AND BLADES

SCULPTEURS ET LAMES

Tipo Type Type	Rigatore Tyre regroover Sculpteur pneus
Modello Model / Modèle	RILLFIT® Six
Potenza elettrica e frequenza Power Supply and frequency Puissance électrique et fréquence	230V, 240V, 110V, 50/60Hz
Peso Weight / Poids	4,4 kg
Classe di protezione Protection class Classe de protection	Classe di protezione isol. 2 Isolated protection class 2 Classe de protection isol. 2
Connessione Connection Connexion	Dispositivo spina e presa Plug and socket device Dispositif secteur et prise de courant
Tipo di frequenza Type of frequency Type de fréquence	Interruzione flusso Interrupting flow Interruption de flux
Tipo di sicurezza Type of safety / Type de sécurité	IXPO
Potenza Power / Puissance	240 Watt
Certificazioni Certifications / Certifications	CE, TuV



3030001

Rigatore Groover Sculpteur



Codice Code Code	Descrizione Description Description	Tensione Tension Tension
3030001	Rigatore / Groover / Sculpteur - Rillfit SIX	230-240V
3030001A	Rigatore / Groover / Sculpteur - Rillfit SIX	115V



3030007



3030009



3030012C



3030013B

Ricambi ed accessori / Spares and accessories / Pièces de rechange et accessoires

Codice Code Code	Descrizione Description Description	Riferimento Reference Référence
3030005	Cavo resistenza Rillfit SIX Heating element Rillfit SIX / Résistance électrique Rillfit SIX	1580156
3030006	Testa porta lame completa Complete blades supporting group / Groupe complet supportant les lames	1580055
3030007	Coppia testine Pair of guides / Paire de guides	1571638
3030008	Coppia viti per testine Pair of screws for guides / Paire de vis pour guides	1700162
3030009	Coppia scorrevoli posteriori Pair of back sliding blocks / Paire de blocs coulissants postérieurs	1580125
3030010B	Selettore rotativo con manopola Rillfit SIX Rotary selector with handle Rillfit SIX / Sélecteur rotatif avec poignée Rillfit SIX	1400103 1400045
3030011	Impugnatura nuda Rillfit SIX Bare handle Rillfit SIX / Poignée nue Rillfit SIX	1400041 1400042, 1700165
3030012B	Cassa trasformatore con maniglia Rillfit SIX Transformer frame with handle Rillfit SIX / Structure du transformateur avec poignée Rillfit SIX	1471421 1400044
3030012C	Interruttore on/off Rillfit SIX Switch on/off Rillfit SIX / Interrupteur on/off Rillfit SIX	1871008
3030013B	Trasformatore Rillfit SIX 230 V Transformer Rillfit SIX / Transformateur Rillfit SIX	-
3030015	Supporto per ruota da scolpire Stand for tyre to be grooved / Support pour pneu à sculpter	-
3030015A	Supporto per ruota da scolpire automatico Automatic stand for tyre to be grooved / Support automatique pour pneu à sculpter	-



3030006



3030010B



3030011

Altri ricambi disponibili su richiesta
Additional spares available on request
Pièces de rechange additionnelles
disponibles sur demande



3030002A



3030003A



3030004

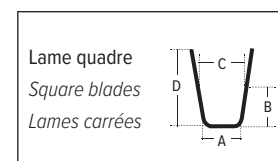
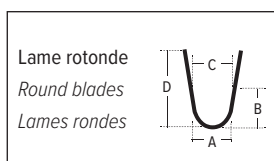

Lame per rigatore Rillfit / Blades for Rillfit groover / Lames pour sculpteur Rillfit

Codice Code Code	Descrizione Description Description	A	B	C	D	Spessore (mm) Thickness Epaisseur	N. lame per confezione N° of blades per box N° de lames par boîte
		Largh. taglio infer. Lower cut width Largeur coupe inf.	Profond. di taglio Cut depth Profond. coupe	Largh. taglio super. Upper cut width Largeur coupe sup.	Profond. lama Blade depth Profond. lame		
3030002A	Lame tonde R1 Round blades R1 Lames rondes R1	3 mm	7 mm	5 mm	21 mm	0,4	20
3030002B	Lame tonde R2 Round blades R2 Lames rondes R2	5 mm	7 mm	8 mm	21 mm	0,4	20
3030002C	Lame tonde R3 Round blades R3 Lames rondes R3	6 mm	10 mm	15 mm	23 mm	0,4	20
3030002D	Lame tonde R4 Round blades R4 Lames rondes R4	8 mm	12 mm	16 mm	25 mm	0,6	20
3030002E	Lame tonde R5 Round blades R5 Lames rondes R5	10 mm	12 mm	18 mm	24 mm	0,6	20
3030003A	Lame quadre W1 Square blades W1 Lames carrées W1	3 mm	7 mm	5 mm	21 mm	0,4	20
3030003B	Lame quadre W2 Square blades W2 Lames carrées W2	5 mm	7 mm	6 mm	21 mm	0,4	20
3030003C	Lame quadre W3 Square blades W3 Lames carrées W3	7 mm	10 mm	10 mm	22 mm	0,4	20
3030003D	Lame quadre W4 Square blades W4 Lames carrées W4	9 mm	12 mm	13 mm	24 mm	0,6	20
3030003E	Lame quadre W5 Square blades W5 Lames carrées W5	11 mm	12 mm	15 mm	23 mm	0,6	20
3030004	Lame quadre giganti W6 Large square blades W6 Lames carrées grandes W6	23 mm	12 mm	28 mm	24 mm	0,6	10

Nota: Altre lame disponibili su richiesta / Note: Other blades available on request / Note: Autres lames disponibles sur demande

ENVELOPES**ENVELOPES****ENVELOPES****Envelopes esterni tipo ST lunghezza gonna standard****ST type outer envelopes regular skirt****Envelopes extérieurs type ST longueur jupe standard**

Codice Code Code	Modello Model Modèle	Diam. Out. Diam.	est x tall. / tall. diam. x bead / bead ext. x talon / talon	Dimensione dei pneumatici suggeriti Size of suggested tyres Dimension des pneus conseillés	Rif. Ref. Réf.
2170530	ST - 44X32	mm inch	1143 x 790 45 x 31	1200-20 • 1300-20 • 365/80-20 • 13-22.5 • 15-22.5 285/75-24.5 • 445/65-22.5 • 1200-24 • 425/65-22.5	SL12 SL13
2170532	ST - 42X28	mm inch	1080 x 710 42.5 x 27,9	385/65-22.5 • 12-22.5 • 1100-20	SL11/12
2170533	ST - 41X28	mm inch	1148 x 715 45 x 28	1100-20 • 315/80-22.5 • 11-24,5	SL11
2170534	ST - 40X26-A	mm inch	1040 x 700 40.9 x 27.5	295/80-22.5 • 315/60-22.5 • 315/70-22.5 • 11-22.5 1000-20 • 295/75-22.5 • 275/80-22.5 • 285/75-24.5 • 445/45-19.5 • 425/45-19.5	SL10
2170535	ST - 40X26	mm inch	1066 x 670 41.9 x 26.3	1000-20 • 295/75-22.5 • 275/80-22.5 • 285/75-24.5	SL10
2170536	ST - 38X23	mm inch	1020 x 600 40 x 23.6	305/70-19.5 • 825-20 • 900-20 • 10-22.5 • 275/70-22.5 305/60-22.5	SL9
2170537	ST - 35X21	mm inch	941 x 545 37 x 24.4	285/70-19.5 • 245/70-19.5 • 265/70-19.5	SLB
2170538	ST - 31X20	mm inch	790 x 508 31 x 20	750-16 • 825-16 • 205/75-17.5 • 8-17.5 • 225/70-17.5 235/75-17.5	SL7
2170539	ST - 28X17	mm inch	739 x 434 29 x 17	600-16 • 650-16 • 700-16	SL6
2170540	ST - 29X22	mm inch	745 x 545 29.3 x 21.4	215/75-16	-

Envelopes esterni tipo ST gonna estesa (cerchio e flangia)**ST type outer envelopes longer skirt (rim and flange)****Envelopes extérieurs type ST jupe longue (jante et bride)**

Codice Code Code	Modello Model Modèle	Diam. Out. Diam.	est x tall. / tall. diam. x bead / bead ext. x talon / talon	Dimensione dei pneumatici suggeriti Size of suggested tyres Dimension des pneus conseillés	Rif. Ref. Réf.
2170545	ST - 44X34	mm inch	1143 x 870 45 x 34.2	1200-20 • 15-22.5 • 445/65-19.5 • 13-22.5 425/65-22.5 • 1200-24	XL13
2170546	ST - 42X31	mm inch	1080 x 790 42.5 x 31.1	385/65-22.5	XL11/12
2170547	ST - 41X30	mm inch	1148 x 750 45 x 29.5	315/70-22.5 • 11-22.5	XL11
2170548	ST - 40X28	mm inch	1066 x 715 41.9 x 28.1	1000-20 • 275/80-22.5	XL10
2170549	ST - 38X25	mm inch	980 x 695 38.5 x 27.4	275/70-22.5	XL9
2170550	ST - 35X25	mm inch	941 x 620 37 x 24.4	245/70-19.5 • 265/70-19.5 285/70-19.5	XL8

Envelopes esterni tipo ST sistema ARC
ST type outer envelopes ARC system
Envelopes extérieurs type ST système ARC

Codice Code Code	Modello Model Modèle	Diam. Out. Diam.	est x tall. / tall. diam. x bead / bead ext. x talon / talon	Dimensione dei pneumatici suggeriti Size of suggested tyres Dimension des pneus conseillés	Rif. Ref. Réf.
2170560	ST - 44X38	mm inch	1143 x 970 45 x 38	1200-20 • 385/65-22.5 • 15-22.5 • 13-22.5 445/65-19.5 • 425/65-22.5 • 1200-24	ARC44X38
2170561	ST - 44X36	mm inch	1143 x 920 45 x 36.2	385/65-22.5	ARC44X36
2170562	ST - 42X36	mm inch	1080 x 920 42.5 x 36.2	315/80-22.5 • 12-22.5 • 1100-20	ARC42X36
2170563	ST - 42X34	mm inch	1080 x 870 42.5 x 34.2	11-24.5	ARC42X34
2170564	ST - 41X34	mm inch	1148 x 870 45 x 34.2	11-22.5 • 315/70-22.5	
2170565	ST - 40X34	mm inch	1040 x 870 40.9 x 34.2	295/80-22.5 • 11-22.5 • 305/70-22.5	ARC40X34
2170566	ST - 40X32	mm inch	1040 x 830 40.9 x 32.7	295/75-22.5 • 275/80-22.5 • 285/75-24.5	ARC40X32
2170566C	ST - 38X32	mm inch	980 x 795 38.5 x 31.3	275/70-22.5 • 10-22.5	—
2170566E	ST - 35X29	mm inch	910 x 740 35.8 x 29	255/70-22.5 • 265/70-22.5 265/70-19.5 • 285/70-19.5	ARC35X29
2170567	ST - 35X27	mm inch	910 x 685 35.8 x 27	245/70-22.5 • 265/70-22.5	—
2170567B	ST - 32X26	mm inch	825 x 665 32.5 x 26.2	245/70-22.5 • 265/70-22.5	ARC32X26
2170568	ST - 32X24	mm inch	825 x 615 32.5 x 24.2	225/70-19.5 • 225/70-22.5	—
2170568B	ST - 29X25	mm inch	745 x 620 29.3 x 24.4	215/70-16 • 215/85-16 • 225/75-16	ARC29X25

Envelopes esterni tipo ST lunghezza gonna ridotta*
ST type outer envelopes short skirt*
Envelopes extérieurs type ST longueur jupe réduit*

Codice Code Code	Modello Model Modèle	Diam. Out. Diam.	est x tall. / tall. diam. x bead / bead ext. x talon / talon	Dimensione dei pneumatici suggeriti Size of suggested tyres Dimension des pneus conseillés	Rif. Ref. Réf.
2170570	ST - 41X22	mm inch	1148 x 570 45 x 22.4	11-24.5	SSL11
2170571	ST - 40X22	mm inch	1066 x 570 41.9 x 22.4	1000-20 • 275/80-22.5 • 295/75-22.5 • 11-22.5 295/80-22.5 • 285/75-24.5	SSL10

* Da usare in combinazione con Envelopes interni Millennium tipo "S"

* To be used in combination with inner Envelopes Millennium "S" type

* À utiliser en combinaison avec Envelopes intérieurs Millennium type "S"

ENVELOPES

ENVELOPES

ENVELOPES

Envelopes esterni

Outer envelopes

Envelopes extérieures

Codice Code Code	Modello Model Modèle	Diam. est Out. diam. Diam. ext.	x	tall. / tall. bead / bead talon / talon	Dimensione dei pneumatici suggeriti Size of suggested tyres Dimension des pneus conseillés
2170597	SL - 14	mm inch		1238 x 965 48 x 38	14.00 - 24 • 14.00-25
2170598	SL - 13	mm inch		1130 x 800 44.4 x 31.5	385/65 - 22.5 • 15 - 22.5 • 445/65 - 22.5 13 - 22.5 • 425/65 - 22.5 • 1200 - 24
2170599	SL - 12	mm inch		1160 x 730 45.6 x 28.7	1200 - 20 • 1300 - 20 • 365/80 - 20 • 13 - 22.5 • 15 - 22.5 385/65 - 22.5 • 285/75 - 24.5
2170600	SL - 11/12	mm inch		1067 x 710 42 x 28	1100 - 20 • 1200 - 20 • 1100 - 22 • 12 - 22.5 • 315/80 - 22.5 • 385/55 - 22.5 11 - 24.5 • 455/45 - 22.5 • 445/65 - 19.5
2170601	SL - 11	mm inch		1020 x 720 40 x 28.4	1100 - 20 • 11 - 22.5 • 12 - 22.5 • 315/75 - 22.5
2170602	SL - 10	mm inch		1000 x 700 39.3 x 27.6	1000 - 20 • 11 - 22.5 • 275/70 - 22.5 • 275/80 - 22.5 295/80 - 22.5 • 305/70 - 22.5 • 315/70 - 22.5 • 425/55 - 19.5
2170602A	SL - 9	mm inch		960 x 630 37.8 x 24.8	900 - 20 • 10 - 22.5 • 305/70 - 19.5 • 305/60 - 22.5
2170603	SL - 8	mm inch		945 x 570 37.4 x 22.4	700 - 20 • 750 - 20 • 825 - 20 8 - 22.5 • 9 - 22.5 • 255/70 - 22.5 • 305/70 - 19.5
2170604	SL - 78	mm inch		890 x 590 35 x 23.2	285/70 - 19.5 • 650 - 20 900 - 15 • 10 - 15 • 10 - 17.5
2170604A	SL - 76	mm inch		840 x 540 33 x 22	825 - 15 • 825-16 • 245/70 - 19.5 • 265/70 - 19.5
2170605	SL - 7	mm inch		795 x 500 31.3 x 20	10 - 16.5 • 12 - 16.5 • 215/75 - 16 • 225/75 - 16 • 215 - 16 750 - 16 • 205 - 16 • 10 - 15 • 7.50 - 15 • 825 - 15 300 - 15 • 8.5/17.5 • 9.5/17.5 • 235/70 - 19.5 • 245/70 - 19.5
2170606	SL - 6	mm inch		714 x 440 28 x 17.3	8 - 17.5 • 700 - 16 • 205/75 - 16 235/75 - 15 • 215 - 15 • 215 - 14 28x9 - 15 • 700 - 15 • 2.50 - 15 • 215/75 - 17.5
2170607	SL - 4	mm inch		650 x 430 25.6 x 17	195 - 14 • 205 - 14 • 185 - 15 • 600 - 16 • 650 - 16 175/75 - 16 • 185 - 16 • 195 - 16 • 7.00 - 12 • 27x10-12 7 - 17.5
2170608	SL - 2	mm inch		610 x 380 24 x 15	165 - 13 • 165 - 14 • 165/70 - 14 • 175 - 14 • 175/70 - 14 • 185 - 14 185/75 - 14 • 750-10 • 23x10-12 • 7.00 - 12
2170609A	SL - 1	mm inch		530 x 390 20.8 x 14.9	23x9-10 • 6.50 - 10
2170609B	SL - 0	mm inch		525 x 335 20.6 x 13.1	21x8-9 • 6.00 - 9
2170609C	SMALL	mm inch		510 x 350 19.5 x 14.1	200X50-10
2170609D	18x13	mm inch		475 x 330 18 x 13	16x6-8 • 500 - 8 • 18X7 - 8



Envelopes esterni tipo "XL" - Outer envelopes type "XL" - Envelopes extérieurs type "XL"

Envelopes esterni tipo "XL" quando è richiesta una gonna più lunga. Quando è usato un cerchio tipo "Oliver" o equivalente
Outer envelopes "XL" type when extra skirt is needed. When a rim type "Oliver" or equivalent flanges are used
 Envelopes ext. type "XL" quand on a besoin d'une bordure plus longue. Quand on utilise une jante type "Oliver" ou correspondante

Codice Code Code	Modello Model Modèle	Diam. est Out. diam. Diam. ext.	x	tall. / tall. x bead / bead x talon / talon	Dimensione dei pneumatici suggeriti Size of suggested tyres Dimension des pneus conseillés
2170610	XL - 13	mm inch		1130 x 880 44,4 x 34.6	1200 - 20 • 385/65 - 22.5 • 15 - 22.5 • 445/65 - 19.5 13 - 22.5 • 425/65 - 22.5 • 1200 - 24
2170610A	XL - 11/12	mm inch		1067 x 790 42 x 31	315/80 - 22.5 • 12 - 22.5 1100 - 20 • 1200 - 20 • 11-22.5
2170610C	XL - 11	mm inch		1020 x 770 40 x 30	305/70 - 22.5 • 315/70 - 22.5 11 - 22.5 • 10-22.5
2170610E	XL - 10	mm inch		1000 x 740 39 x 29	275/80 - 22.5 • 305/70 - 19.5 295/80-22.5 • 1000-20 • 9-22.5 • 265/75-22.5
2170610F	XL - 9	mm inch		960 x 660 37.8 x 26	900 - 20
2170610G	XL - 8	mm inch		945 x 640 37 x 25	700 - 20 • 750 - 20 825 - 20
2170610L	XL - 76	mm inch		840 x 570 33 x 23	245/70 - 19.5
2170610N	XL - 7	mm inch		795 x 600 31 x 24	8-17.5 • 8.5 - 17.5 750 - 16 • 205 - 16
2170610Q	XL - 6	mm inch		714 x 465 28 x 18.3	215/75 - 17.5
2170610R	XL - 14	mm inch		1238 x 1070 48 x 42	1400 - 24 • 1400 - 25

Envelopes esterni "Arc" - Outer envelopes "Arc" - Envelopes extérieurs "Arc"

Quando è usato un cerchio tipo "Arc" o equivalente - *When a rim type "Arc" or equivalent is used. Quand on utilise une jante type "Arc" ou correspondante*

Codice Code Code	Modello Model Modèle	Diam. est Out. diam. Diam. ext.	x	tall. / tall. x bead / bead x talon / talon	Dimensione dei pneumatici suggeriti Size of suggested tyres Dimension des pneus conseillés
2170611N	48 X 45	mm inch		1238 x 1143 48.7 x 45	1400 - 24 • 445/65 - 22.5 • 425/65 - 22.5 455/55 - 22.5
2170612	44 X 38	mm inch		1130 x 980 44.4 x 38.5	1200 - 20 • 385/65 - 22.5 • 15 - 22.5 • 445/65 - 19.5 • 1200 - 24 13 - 22.5 • 425/65 - 22.5
2170612A	44 X 36	mm inch		1130 x 915 44.4 x 36	385/65 - 22.5
2170613	42 X 36	mm inch		1075 x 920 42.3 x 36.2	315/80 - 22.5 • 315/75 - 22.5 • 335/80 - 20 • 12 - 22.5 13/80 - 20 • 12/80 - 20
2170613A	42 X 34	mm inch		1075 x 864 42.3 x 34	11-24.5 • 295/80 - 24.5 • 12-22.5 • 305/85 - 22.5
2170614	40 X 34	mm inch		1020 x 870 40 x 34.2	11 - 22.5 • 10 - 22.5 • 385/55 - 22.5 315/70 - 22.5 • 295/80 - 22.5 • 285/75 - 24.5
2170614A	40 X 32	mm inch		1020 x 813 40 x 32	285/75 - 24.5 • 295/70 - 22.5 • 295/75 - 22.5 • 305/70 - 22.5 275/80 - 22.5 • 295/80 - 22.5 • 11 - 22.5 • 1100 - 20 • 1000 - 20
2170614B	35 X 31	mm inch		889 x 787 35 x 31	275/70-22.5
2170614D	35 X 29	mm inch		889 x 752 35 x 29.6	255/70 - 22.5 • 275/70 - 22.5 • 305/70 - 19.5 • 265/70 - 22.5 285/70 - 19.5 • 245/70 - 19.5 • 245/75 - 22.5
2170614F	32 X 28	mm inch		816 x 712 32.1 x 28	235/70 - 19.5 • 265/70 - 19.5 • 245/70 - 19.5 • 245/65 - 19.5 225/90 x 17.5 • 9.5 - 17.5 • 8.25 - 16
2170614H	32 X 26	mm inch		816 x 660 32.1 x 26	225/75 -17.5 • 235/75 - 17.5 • 225/70 - 19.5 245/75 -16
2170614L	29 X 25	mm inch		725 x 650 28.5 x 25.6	700-16 • 225/75 - 16 • 205/75 - 16 • 215/75 - 17.5 215/85 - 16 • 215/75 - 15 • 750 - 16
2170614N	27 X 21	mm inch		680 x 590 26.8 x 23.2	185/75 - 16 • 195/75 - 16 • 195/75 - 14

ENVELOPES

ENVELOPES

ENVELOPES

Envelopes interni Universal Inner envelopes Universal Envelopes intérieures Universal

Codice Code Code	Misura Size Dimension	Dimensioni dei pneumatici suggerite Suggested tyre sizes Dimensions pneu conseillées	Dimensioni (mm) Sizes (mm) Dimensions (mm)		
			A	B	C
2170615B	1340 x 560	1100-24 • 1200-24 • 1300-24 • 12-24,5 • 1400-24	1340	560	970
2170615	1300 x 500	16.5-22.5 • 18-22.5 • 425/65-22.5 • 445/65-22.5	1300	500	900
2170616	1200 x 560	285/75-24.5 • 295/75-24.5 • 305/75-24.5 • 315/75-24.5 285/80-24.5 • 295/80-24.5 • 305/80-24.5	1200	560	870
2170616D	1160 x 480	385/65 - 22.5 • 12.00-20 • 13.00-20 • 13.80-20 • 14.80-20 • 365/80-20 • 15-22.5 1400 - 20	1160	480	900
2170617	1100 x 480	1100-20 • 1200-20 • 1100-22 • 425/55-19.5 • 12-22.5 • 13-22.5 • 15-22.5 305/70-22.5 • 315/75-22.5 • 315/80-22.5 • 385/65-22.5	1100	480	860
2170618	1060 x 480	11-22.5 • 275/80-22.5 • 295/80-22.5 • 445/45-22.5 • 385/55-22.5	1060	480	810
2170619	1010 x 480	8.25-20 • 900-20 • 1000-20 • 10-22.5 • 305/70-19.5 • 305/60 - 22.5 255/70-22.5 • 275/70-22.5 • 285/70-22.5 • 305/70-22.5 • 12-16.5 • 315/60-22.5	1010	480	790
2170620	960 x 440	265/70-19.5 • 285/70-19.5 • 435/50-19.5	960	440	690
2170621	880 x 380	825-15 • 825-16 • 9.5-17.5 • 10-17.5 • 245/70 - 19.5 • 235/75 - 19.5	880	380	675
2170622	780 x 400	7.50-15 • 700-16 • 750-16 • 215/75-16 • 225/75-16 • 750-16 8-17.5 • 8.5-17.5 • 9-17.5 • 205/75-17.5 • 215/75-17.5 • 235/75-17.5	780	400	640
2170623	700 x 315	195-14 • 205-14 • 215-14 • 250/70-15 • 700-15 • 10-16.5 185/75-16 • 195/75-16 • 600-16 • 6.50-16 • 205/75-16	700	315	570

Envelopes interni Millennium S Inner envelopes Millennium S Envelopes intérieures Millennium S

Codice Code Code	Misura Size Dimension	Dimensioni dei pneumatici suggerite Suggested tyre sizes Dimensions pneu conseillées	Dimensioni (mm) Sizes (mm) Dimensions (mm)		
			A	B	C
2170616Q	1180 x 580 S	11 - 24.5	1180	580	940
2170616J	1160 x 540 S	315/80-22,5 • 15-22.5	1160	540	930
2170617C	1100 x 480 S	1100-20 • 1100-22 • 12-22.5 • 13-22.5 • 385/65-22.5 • 15-22.5 • 305/70-22.5 315/80-22.5 • 315/75 - 22.5	1100	480	930
2170617D	1100 x 540 S	385/65-22,5 • 1100-22 • 12-22.5 • 13-22.5 • 15-22.5 • 305/70-22.5 315/75-22.5 • 315/80-22.5	1100	540	930
2170617M	1060 x 540 S	275/80-22,5 • 295/80-22,5 • 305/70-22.5 • 11-22,5 • 1100-22 • 12-22.5 13-22.5 • 385/65-22.5 • 15-22,5 • 315/75-22.5	1060	540	900
2170618D	1060 x 480 S	1000-20 • 275/80-22.5 • 295/80-22.5 • 305/70-22.5 • 11-22.5 • 1100-22 • 12-22.5 • 13-22.5 385/65-22.5 • 15-22.5 • 315/75-22.5 • 315/80-22.5 • 425/45-19.5 • 455/45-22.5 • 385/55-22.5	1060	480	900
2170620D	930 x 465 S	245/70-19,5 • 225/70-19.5	930	465	700

L'envelope ha un foro per la valvola e questa zona è rinforzata - I prezzi delle envelopes non includono la valvola.

The envelope has a hole for the valve and this area is reinforced. Envelopes prices do not include the valve.

L'envelope a un trou pour la valve et cette zone est renforcée - La valve n'est pas incluse dans les prix des envelopes.

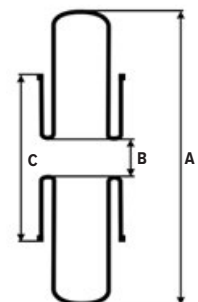

Envelopes interni per gomme piene
Inner envelopes for solid tyres
Envelopes intérieures pour pneus pleins

Codice Code Code	Misura Size Dimension	Dimensioni dei pneumatici suggerite Suggested tyre sizes Dimensions pneu conseillées	Dimensioni Sizes Dimensions		
			A	B	C
2170701	5.00-8	15x4 ¹ / ₂ -8 • 125/75-8 • 4.00-8 • 5.00-8	350	180	105 mm
2170703	18x7-8 (16x6-8)	18x7-8 • 180/70-8 • 150/75-8 • 16x6-8	350	150	130 mm
2170711	6.00-9	6.00-9	420	200	115 mm
2170712	21x8-9	21x8-9 • 200/75-9	420	225	180 mm
2170721	6.50-10	6.50-10	480	220	150 mm
2170722	200/50-10	200/50-10	400	230	180 mm
2170723	23x9-10	23x9-10 • 225/75-10	490	230	180 mm
2170731	7.00-12	7.00-12	530	270	150 mm
2170732	23x10-12	23x10-12	460	270	230 mm
2170733	27x10-12	27x10-12 • 250/75-12	530	270	230 mm
2170741	8.25-15	2.00-15 • 7.50-15 • 8.25-15	650	360	190 mm
2170742	2.50-15	2.50-15 • 225/75-15 • 250/70-15 • 28x9-15	570	360	200 mm
2170743	3.00-15	3.00-15 • 315/70-15	650	360	240 mm
2170744	10.00-20	10.00-20 • 12.00-20	870	510	190 mm

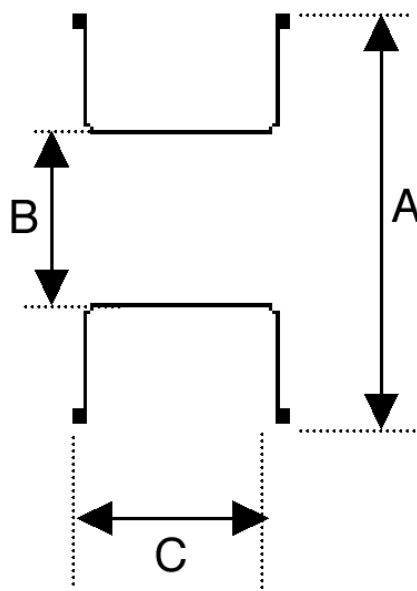

ENVELOPES

ENVELOPES

ENVELOPES

Cuscini per vuoto Envelope Envelope vacuum pads Coussins pour vide Envelope

- Prodotto in gomma butilica particolarmente resistente al calore (da 100°C a 150°C);
- L'elasticità della mescola non provoca deformazione al battistrada;
- Idoneo a qualsiasi tipo di sistema prestampato;
- Evita l'impronta della valvola envelope sul battistrada;
- Estetica perfetta del pneumatico (nessuna impronta);
- Applicazione semplice e veloce - non necessita fissaggio;
- Lunga durata.
- Produced in butyl rubber particularly heat resistant

- (from 100°C to 150°C);
- The high elasticity of the compound doesn't generate deformations to the tread;
- Suitable for any kind of precured tread system;
- It avoids the impression of the envelope valve on the tread;
- Perfect design of tyre (no impression);
- Easy and quick application - no fixing required;
- Long life.
- Produit en caoutchouc butylique particulièrement ré-

- sistant à la chaleur (de 100°C à 150°C);
- La haute élasticité du mélange ne cause pas de déformations à la chape;
- Indiqué pour tous types de système bande prévulcanisée;
- Il évite l'empreinte de la valve envelope sur la chape;
- Design parfait du pneu (pas d'empreinte);
- Application facile et rapide - pas besoin de fixation;
- Longue durée.

Codice Code Code	Descrizione Description Description	Dimensioni (mm) Sizes (mm) Dimensions (mm)		Sistema Prestampato Precured tread system Système bande prévulcanisée
		A	B	
2170800	Cuscino per vuoto Envelope Super single Super single envelope vacuum pad Coussin pour vide envelope Super single	1385	165	Sistema doppio envelope Double envelope system Système envelope double
2170801	Cuscino per vuoto envelope Super single Super single envelope vacuum pad Coussin pour vide envelope Super single	740	165	Envelope / Cerchio / Camera - Sistema ARC Envelope / Rim / Tube - ARC system Envelope / Jante / Chambre - Système ARC
2170802	Cuscino per vuoto envelope Autocarro Truck envelope vacuum pad Coussin pour vide envelope camion	1250	175	Sistema doppio envelope Double envelope system Système envelope double
2170803	Cuscino per vuoto envelope Autocarro Truck envelope vacuum pad Coussin pour vide envelope camion	670	175	Envelope / Cerchio / Camera - Sistema ARC Envelope / Rim / Tube - ARC system Envelope / Jante / Chambre - Système ARC
2170804	Cuscino per vuoto envelope Trasporto medio leggero Medium light truck envelope vacuum pad Coussin pour vide envelope petite camionnette	835	135	Sistema doppio envelope Double envelope system Système envelope double
2170805	Cuscino per vuoto envelope Trasporto medio leggero Medium light truck envelope vacuum pad Coussin pour vide envelope petite camionnette	450	135	Envelope / Cerchio / Camera - Sistema ARC Envelope / Rim / Tube - ARC system Envelope / Jante / Chambre - Système ARC

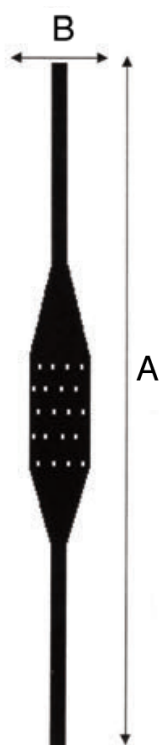

Fustini di cottura
Curing bladders
Membranes de cuisson

Codice Code Code	Misura Size Dimension	H mm	A mm	B mm	C mm	D mm	kg	Pneumatico suggerito Suggested tyre Pneu conseillé
2160581	CO (4776)	311	302	203	21	12,7	3,1	125-12 • 135-12
2160582	C1 (6299)	330	325	217	22	13	3,7	135-13 • 145-13
2160583	C2 (6228)	330	370	217	22	13	4,5	155-13 • 165-13
2160584	C3 (6297)	464	412	248	21	13	5,8	T.L./Light Van
2160584A	C4 (6390)	410	400	248	21	13	5,2	T.L./Light Van
2160584B	C5 (6319)	460	435	270	21	13	7,4	T.L./Light Van
2160584C	C6 (6320)	550	435	270	21	13	8,5	T.L./Light Van
2160584F	C83 (8376)	525	600	375	26	12,5	13,4	Truck 20"/22"/22.5" medium
2160584G	C28 (2895)	615	600	375	26	12,5	15,3	Truck 20"/22.5" large
2160584H	C76 (7646)	455	663	445	32	16	18,4	Truck 24"
2160584L	C20/6 (H 20/6)	545	822	375	26	13	18,8	Truck 22.5" large
2160584P	MO (RP-12/1)	227	420	207	23	11	2,8	10"/12"
2160585	M1 (RP-13/3)	300	410	225	23	11	3,7	135-13 • 145-13
2160586	M2 (RP-13/4)	320	410	225	23	11	3,9	155-13 • 165-13
2160587	M3 (RP-13/5)	345	450	225	23	12,5	4,5	175-14 • 185-14
2160588	M4 (RP-13/7)	395	450	225	23	12,5	4,9	195-14 • 205-15
2160589	M5 (RP-13/9)	490	467	225	23	11	6,4	T.L./Light Van
2160590	M20/35 (RP-20/3)	480	665	345	28	15,5	11,4	Truck 20"/22.5" medium
2160591	M20/5 (RP-20/5)	550	665	345	28	15,5	12,6	Truck 20"/22.5" large
2160592	V28 (DK-38428)	220	417	235	24	12	2,6	Motorcycle 17"/18"
2160593	V30/4 (13 DXT-330/4)	215	454	220	23	12	2,4	Motorcycle 18"/19"
2160594	V16	119	416	345	14	6	1,2	Motorcycle 17"
2160595	V76	245	298	215	25	12	2,5	Motorcycle 14"

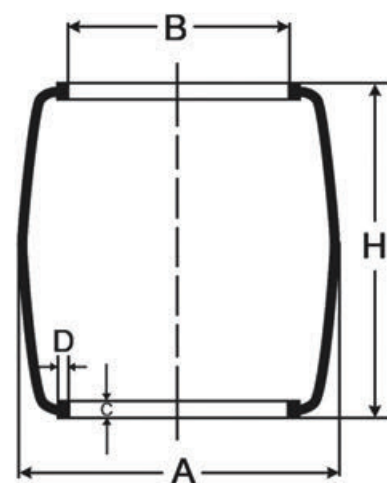

CAMERE DI COTTURA

CURING TUBES

CHAMBRES DE CUISSON

Butyl tipo "SUPER RINFORZATE" Butyl type "SUPER REINFORCED" Butyl type "SUPER RENFORCÉES"

Codice Code Code	Ø Ø Ø	Dimensione dei pneumatici suggeriti Size of suggested tyres Dimension des pneus conseillés	
2150503	10	450 - 10	
2150504	10	145 - 10	
2150505	12	125 - 12	
2150506	12	135 - 12	
2150507	12	145/155 - 12	520/560/600 - 12
2150509	13	135 - 13	
2150510	13	145 - 13	
2150511	13	155 - 13	615 - 13
2150512	13	165 - 13	560 - 13
2150513	13	175 - 13	640 - 13
2150513S	13	185/60 - 13	
2150514	14	145 - 14	
2150515	14	155 - 14	560 - 14
2150516	14	165 - 14	650 - 14
2150517	14	175/185 - 14	
2150518	14	185/195/60 - 14	
2150519	14	195/205 - 14	750 - 14
2150521	15	135/145 - 15	
2150523	15	155 - 15	560/600 - 15
2150525	15	175/185 - 15	
2150526	15	185/195/60 - 15	
2150527	15	205/215 - 15	
2150527S	15	650/670 - 15	
2150528A	16	175 - 16	600/640 - 16
2150528B	16	195 - 16	650 - 16
2150530	16	205 - 16	700 - 16
2150530C	16	205/55-16	
2150531	16	750 - 16	
2150532	16	825 - 16	
2150532A	17	425 - 17	130/80 - 17
2150533D	17	225/45 - 17	
2150533	17.5	8/8.5 - 17.5	
2150533E	18	235/40 - 18	
2150534	20	750 - 20	
2150535	20	825 - 20	
2150536	20	900 - 20	
2150537	20	1000 - 20	
2150538	20	1100 - 20	
2150539	20	12/1300 - 20	
2150540	22.5	11/12 - 22.5	
2150541	22.5	315/80 - 22.5	
2150541A	22.5	385/65 - 22.5	
2150541C	24,5	11-24,5	

Butyl tipo "RINFORZATE" Butyl type "REINFORCED" Butyl type "RENFORCÉES"

Codice Code Code	Ø Ø Ø	Dimensione dei pneumatici suggeriti Size of suggested tyres Dimension des pneus conseillés	
2150542	14	195/205 - 14	
2150543	15	175/185 - 15	
2150544	15	205/215 - 15	
2150545A	16	195 - 16	650 - 16
2150545B	16	205 - 16	700 - 16
2150546	16	750 - 16	
2150547	16	825 - 16	
2150548	19.5	265/70 - 19.5	
2150548A	19.5	305/70 - 19.5	
2150549	20	750 - 20	
2150550	20	825 - 20	
2150551	20	900 - 20	
2150552	20	1000 - 20	
2150553	20	1100 - 20	
2150554	20	12/1300 - 20	
2150555	22.5	11/12 - 22.5	
2150556	22.5	315/80 - 22.5	
2150556A	22.5	385/65 - 22.5	
2150557	24	13/1400 - 24	
2150558	24.5	11 - 24.5	1200 - 24

NOTE / NOTES / NOTES:

- La camera tipo "R" richiede sempre l'uso del flap
- "R" model curing tubes should always be used with flap
- Les chambres de cuisson modèle "R" doivent toujours être utilisées avec le flap



NOTE / NOTES / NOTES:

- Per le camere tipo "S" l'uso del flap dipende dalle condizioni d'uso.
- For "S" model curing tubes the flap use depends on use conditions.
- Pour les chambres de cuisson modèle "S" l'utilisation du flap dépend des conditions d'utilisation.

Butyl tipo "ULTRA"
Butyl type "ULTRA"
Butyl type "ULTRA"

Codice Code Code	Ø Ø Ø	Dimensione pneumatici Tyre sizes Dimensions pneus
2150600	15	750 - 15
2150602	16	700 - 16
2150604	16	750 - 16
2150606	17	750 - 17
2150607	20	825 - 20
2150608	20	900 - 20
2150610	20	1000 - 20
2150612	20	1100 - 20
2150614	20	1200 - 20
2150616	22.5	275 / 295 - 22.5
2150617	22.5	315 / 80 - 22.5
2150618	22.5	385 / 65 - 22.5
2150619	22.5	11 - 22 / 22.5
2150620	24/24.5	11 - 24.5

Tipo "ULTRA" con piastrina di protezione, valvola estraibile, piede piatto.

Le camere di cottura ULTRA sono leggere e facili da maneggiare, così da essere utilizzate nel processo di ricostruzione prevulcanizzato (sistema a freddo). Sono realizzate con una speciale miscela per ottenere le migliori prestazioni in termini di durata.

Type "ULTRA" with rubber base, stem valve, flat basis.

The curing tubes ULTRA are light and easy to handle, to be used in cold retreading system. They are made of a special compound to gain the best performances in terms of life.

Type "ULTRA" avec plaquette de protection, valve extractible, base plate.

Les chambres de cuisson ULTRA sont légères et faciles à manier, pour être utilisées en le procès de rechapage pré-vulcanisé (système à froid). Elles sont faites en un mélange spécial pour obtenir les performances les meilleures en termes de durée.



Butyl flaps per ricostruzione pneumatici - Anello

Butyl flaps for tyres' retreading - Ring

Flaps butyl pour rechapage pneus - Anneau

Codice Code Code	Ø Ø Ø	Misura Size Dimension	Peso Weight kg Poids	Dimensione pneumatici Tyre sizes Dimensions pneus
2150570	16	B - 16	1.2	600 / 640 / 650 / 700 / 750 - 16
2150571	20	B - 20	2.7	750 / 825 / 900 - 20
2150572	20	E - 20	3.4	10 / 11 / 1200 - 20
2150573	22.5	P - 22.5	3.7	315 / 80 - 22.5 - 11 / 12 / 13 - 22.5



Butyl flaps per ricostruzione pneumatici - Striscia

Butyl flaps for tyres' retreading - Strip

Flaps butyl pour rechapage pneus - Bande

Codice Code Code	Ø Ø Ø	Misura Size Dimension	Peso Weight kg Poids	Dimensione pneumatici Tyre sizes Dimensions pneus
2150573S	24	F - 24	5.2	1300 - 24 / 1400 - 24
2150574	25	F - 25	8.4	15 / 17.5 - 25
2150574A	25	F - 25 L	9.1	20.5 - 25 / 23.5 - 25
2150575	28	F - 28	6.8	13 - 28
2150576	30	F - 30	10	Cerchio / Rim / Jante 30"
2150577	34	F - 34	9.5	Cerchio / Rim / Jante 34"
2150578	38	F - 38	20,3	Cerchio / rim / jante 38"



MATERIALE AUTOVULCANIZZANTE ITALREPAIR

ITALREPAIR SELF-CURING MATERIAL

MATÉRIEL AUTOVULCANISANT ITALREPAIR

italrepair





Rappazzi per riparazioni pneumatici radiali
Patches for radial tyres repairing
Emplâtres pour réparation pneus radiaux

Codice Code Code	Descrizione Description Description	Misure (mm) Size (mm) Dimension (mm)	Pz. / scatola Pcs. / box Pcs. / boîte
3070040IT	RAD TL 110	50X75	20
3070041IT	RAD TL 116	67X104	20
3070042IT	RAD TL 115	75X90	10
3070043IT	RAD TL 120	80X125	10
3070044IT	RAD TL 122	75X175	10
3070045IT	RAD TL 124	75X220	10
3070046IT	RAD TL 125	115X125	10
3070047IT	RAD TL 135	130X180	5
3070048IT	RAD TL 140	100X200	5
3070049IT	RAD TL 142	130X260	5
3070050IT	RAD TL 180	150X190	5
3070051IT	RAD TL 182	185X240	5



3070040IT

MATERIALE AUTOVULCANIZZANTE ITALREPAIR

ITALREPAIR SELF-CURING MATERIAL

MATÉRIEL AUTOVULCANISANT ITALREPAIR



Rappezzi universali per forature in scatola Universal patches for puncture injuries in boxes Emplâtres universels pour crevaisons en boîte

Codice Code Code	Descrizione Description Description	Misure (mm) Size (mm) Dimension (mm)	Pz. / scatola Pcs. / box Pcs. / boîte
3070070IT	UP3 ROUND	36	100
3070071IT	UP4,5 ROUND	45	100
3070060IT	UP4.5 SQUARE	45X45	100
3070061IT	UP6 SQUARE	60X60	50
3070062IT	UP8 SQUARE	67X67	50

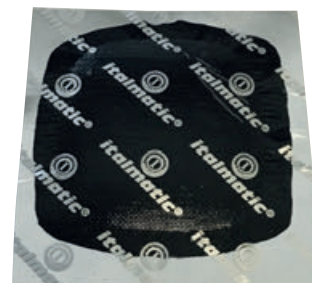

Rappezzi universali per forature in secchiello Universal patches for puncture injuries in pail Emplâtres universels pour crevaisons en seaux

Codice Code Code	Descrizione Description Description	Misure (mm) Size (mm) Dimension (mm)	Pz. / scatola Pcs. / box Pcs. / boîte
3070070AIT	UP3 ROUND (secchiello / pail / seau)	36	500
3070071AIT	UP4,5 ROUND (secchiello / pail / seau)	45	300
3070060AIT	UP4.5 SQUARE (secchiello / pail / seau)	45X45	300
3070061AIT	UP6 SQUARE (secchiello / pail / seau)	60X60	200

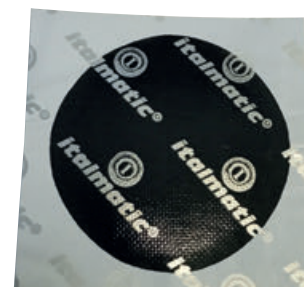

Rappezzi per pneumatici diagonali
Patches for bias tyres
Emplâtres pour pneus diagonaux

Codice Code Code	Descrizione Description Description	Misure (mm) Size (mm) Dimension (mm)	Tele Plies Toiles	Pz. / scatola Pcs. / box Pcs. / boîte
3070080IT	BIAS-3	108	2	10
3070081IT	BIAS-4	125	4	10
3070082IT	BIAS-5	160	4	10
3070083IT	BIAS-6	262	6	5

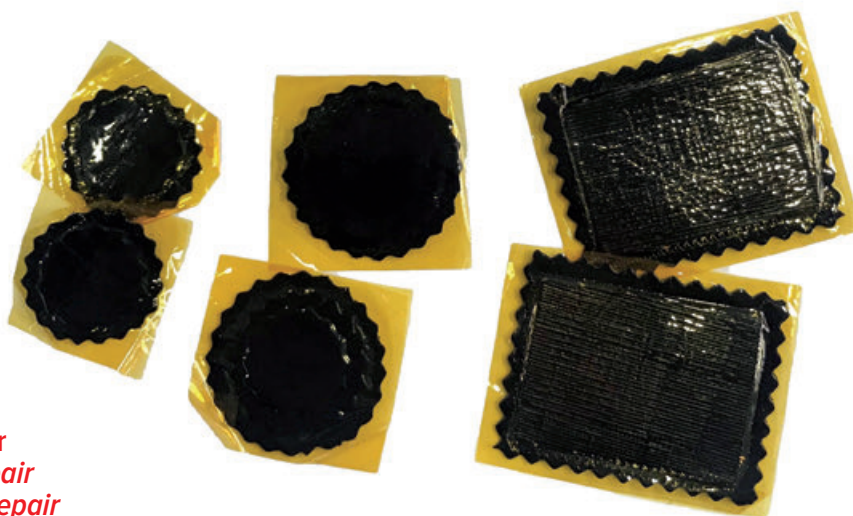
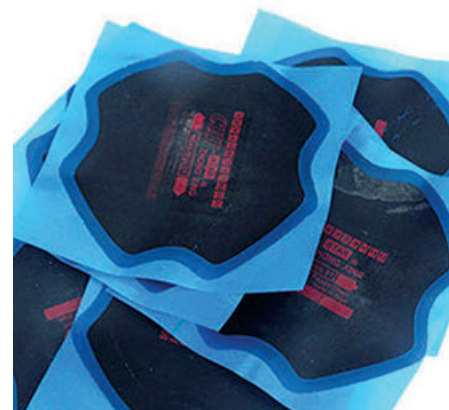

Pezze HEAT PRESS Italrepair
HEAT PRESS patches Italrepair
Emplâtres HEAT PRESS Italrepair

Codice Code Code	Descrizione Description Description	Misure (mm) Size (mm) Dimension (mm)	Pz. / scatola Pcs. / box Pcs. / boîte
3070250IT	Italrepair HEAT PRESS patch HP01 Italrepair HEAT PRESS patch HP01 / Italrepair HEAT PRESS emplatre HP01	37	100
3070255IT	Italrepair HEAT PRESS patch HP02 Italrepair HEAT PRESS patch HP02 / Italrepair HEAT PRESS emplatre HP02	44	50
3070260IT	Italrepair HEAT PRESS patch HP03R Italrepair HEAT PRESS patch HP03R / Italrepair HEAT PRESS emplatre HP03R	66x55	50



Pellicola di cottura
Curing heat resistant foil
Pellicule pour cuisson

Codice Code Code	Descrizione Description Description	Larghezza Width Largeur	Spessore Thickness Épaisseur	Kg	Lunghezza Length Longueur
3070200IT	Italrepair pellicola di cottura HEAT RESISTANT FOIL Italrepair curing HEAT RESISTANT FOIL Pellicule pour cuisson	50 cm	23 micron	30 approx	5 Mt approx

MATERIALE AUTOVULCANIZZANTE ITALREPAIR

ITALREPAIR SELF-CURING MATERIAL

MATÉRIEL AUTOVULCANISANT ITALREPAIR



3070145IT

3070146IT



3070147IT

3070148IT

Soluzioni auto vulcanizzanti Self-curing cements Solutions auto-vulcanisantes

Codice Code Code	Descrizione Description Description	Contenuto Content Contenu
3070145IT	Soluzione autovulcanizzante ITALMATIC FAST DRY <i>ITALMATIC FAST DRY self-curing cement</i> <i>Solution auto-vulcanisante ITALMATIC FAST DRY</i>	1 LT
3070146IT	Soluzione autovulcanizzante ITALMATIC FAST DRY <i>ITALMATIC FAST DRY self-curing cement</i> <i>Solution auto-vulcanisante ITALMATIC FAST DRY</i>	250ML
3070147IT	Soluzione autovulcanizzante ITALMATIC HD BLUE <i>ITALMATIC HD BLUE self-curing cement</i> <i>Solution auto-vulcanisante ITALMATIC HD BLUE</i>	1 LT
3070148IT	Soluzione autovulcanizzante ITALMATIC HD BLUE <i>ITALMATIC HD BLUE self-curing cement</i> <i>Solution auto-vulcanisante ITALMATIC HD BLUE</i>	250 ML
3070149IT	Soluzione autovulcanizzante ITALMATIC FAST DRY <i>ITALMATIC FAST DRY self-curing cement</i> <i>Solution auto-vulcanisante ITALMATIC FAST DRY</i>	20 ML TUBE
3070150IT	Soluzione autovulcanizzante ITALMATIC FAST DRY <i>ITALMATIC FAST DRY self-curing cement</i> <i>Solution auto-vulcanisante ITALMATIC FAST DRY</i>	70 ML TUBE



3070152IT

3070151IT

Sigillante riparazioni
Repair sealer
Solution pour réparations

Codice Code Code	Descrizione Description Description	Contenuto Content Contenu
3070151IT	Sigillante per riparazioni ITALMATIC REPAIR SEALER ITALMATIC REPAIR SEALER Solution pour réparations ITALMATIC REPAIR SEALER	250 ML
3070152IT	Sigillante per riparazioni ITALMATIC REPAIR SEALER ITALMATIC REPAIR SEALER Solution pour réparations ITALMATIC REPAIR SEALER	1 LT



3070170IT

Sigillante talloni
Bead sealer
Solution pour talons

Codice Code Code	Descrizione Description Description	Contenuto Content Contenu
3070170IT	Sigillante per talloni ITALMATIC BEAD SEALER ITALMATIC BEAD SEALER Solution adhesive pour talons ITALMATIC REPAIR SEALER	1 LT



3070154IT

Liquido buffer
Buffer liquid
Liquide buffer

Codice Code Code	Descrizione Description Description	Contenuto Content Contenu
3070154IT	Liquido per pulizia ITALMATIC BUFFER ITALMATIC BUFFER liquid for cleaning Liquide pour nettoyage ITALMATIC BUFFER	1 LT



MATERIALE AUTOVULCANIZZANTE ITALREPAIR

ITALREPAIR SELF-CURING MATERIAL

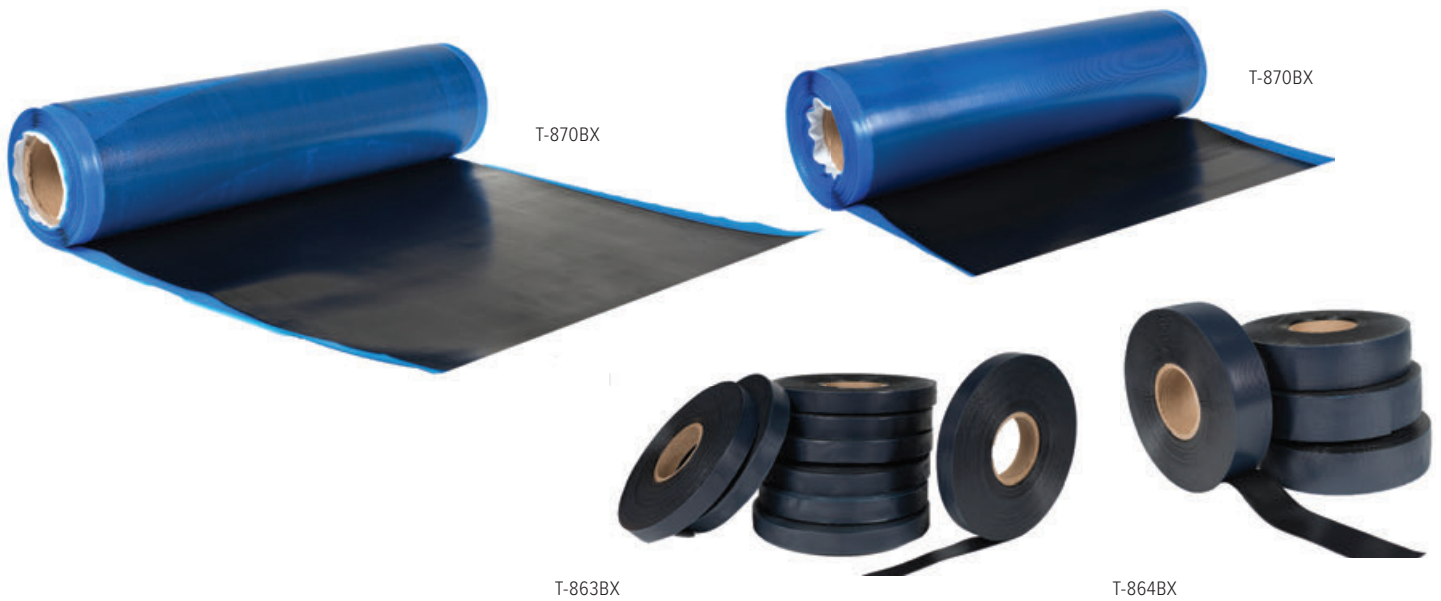
MATÉRIEL AUTOVULCANISANT ITALREPAIR

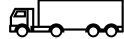

Para a caldo
Cushion gum rubber
Caoutchouc de para a 'chaud

Codice Code Code	Descrizione Description Description	Misure (mm) Size (mm) Dimension (mm)	Peso Weight Poids	Pz. / scatola Pcs. / box Pcs. / boîte			
T-849BX	VUL-GUM Cushion Gum	6 x 150	4.5 kg	1	•	•	•
T-850BX	VUL-GUM Cushion Gum	3 x 150	4.5 kg	1	•	•	•
T-862BX	VUL-GUM Cushion Gum	3 x 475	4.5 kg	1	•	•	•
T-867BX	VUL-GUM Cushion Gum	1.5 x 475	6.8 kg	1	•	•	•
T-868BX	VUL-GUM Cushion Gum	0.8 x 475	6.8 kg	1	•	•	•
T-869BX	VUL-GUM Cushion Gum	3 x 750	6.8 kg	1	•	•	•
T-870BX	VUL-GUM Cushion Gum	1.5 x 750	6.8 kg	1	•	•	•
T-855BX	VUL-GUM Stripping Stock	0.4 x 25	.5 kg	5	•	•	•
T-861BX	VUL-GUM Stripping Stock	3 x 25	.9 kg	9	•	•	•
T-863BX	VUL-GUM Stripping Stock	1.5 x 25	.9 kg	9	•	•	•
T-864BX	VUL-GUM Stripping Stock	1.5 x 50	1.8 kg	4	•	•	•
T-865BX	VUL-GUM Stripping Stock	1.5 x 75	2.7 kg	3	•	•	•
T-866BX	VUL-GUM Stripping Stock	1.5 x 100	3.6 kg	2	•	•	•



Sottostrato per riparazioni
Cushion gum for repairing
Substrat pour les réparations

Codice Code Code	Descrizione Description Description	Misure (mm) Size (mm) Dimension (mm)	Peso Weight Poids	Pz. / scatola Pcs. / box Pcs. / boîte
T-643	Sottostrato per riparazioni / Cushion Gum for repairing / Substrat pour les reparations	1,2	20 kg	1

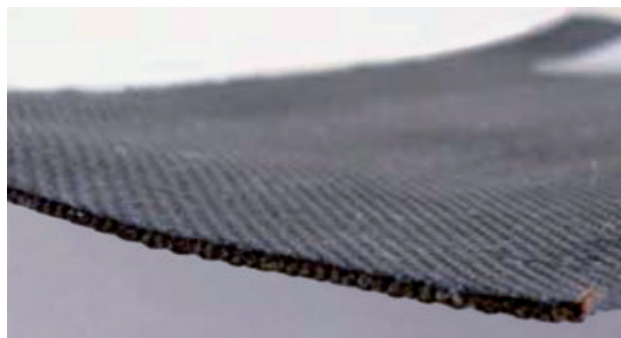

TECH Tessuto in gomma per riparazioni
Rubber textile for repairing
Textile en caoutchouc pour réparation

Codice Code Code	Descrizione Description Description	Misure (mm) Size (mm) Dimension (mm)	Pz. / scatola Pcs. / box Pcs. / boîte
T-644	Tessuto in Nylon 2 capi / Nylon textile 2 wires / Tissu Nylon 2 fils	SP: 1 mm H: 1400 mm	1
T-645	Tessuto in Ryon 2 capi / Ryon textile 2 wires / Tissu Rayon 2 fils	SP: 1 mm H: 1430 mm	1
T-646	Tessuto in Kevlar / Kevlar textile / Tissu Kevlar	SP: 1 mm H: 1400 mm	1
T-647	Tessuto in Kevlar / Kevlar textile / Tissu Kevlar	SP: 0,75 mm H: 1400 mm	1

Para Butyl Gum & Chemical Cure

Gomma per riparazione del liner interno - a caldo
Heat cure innerliner repair gum
Caoutchouc pour réparation a 'chaud du liner intérieur

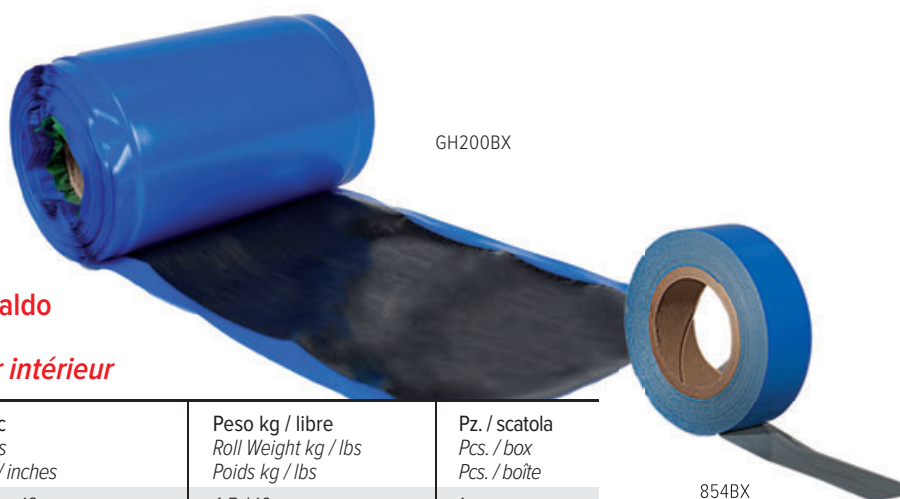

Codice Code Code	Descrizione Description Description	misure mm / inc Size mm / inches Dimension mm / inches	Peso kg / libre Roll Weight kg / lbs Poids kg / lbs	Pz. / scatola Pcs. / box Pcs. / boîte
T-BTLG-125/10#BX	Butyl Gum	0.8 x 425 / 1/32 x 19	4.5 / 10	1
T-848BX	Butyl Gum	0.8 x 100 / 1/32 x 4	4.5 / 10	1

Gomma per riparazione del liner interno - a freddo
Chemical cure innerliner repair gum
Caoutchouc pour réparation a 'froid du liner intérieur

Codice Code Code	Descrizione Description Description	misure mm / inc Size mm / inches Dimension mm / inches	Peso kg / libre Roll Weight kg / lbs Poids kg / lbs	Pz. / scatola Pcs. / box Pcs. / boîte
T-GH100BX	Chemical Cushion Gum	0.8 x 150 / 1/32 x 6	2.72 / 6	1
T-GH200BX	Chemical Cushion Gum	0.8 x 225 / 1/32 x 9	5 / 11	1
T-GH218BX	Chemical Cushion Gum	0.8 x 450 / 1/32 x 18	5 / 11	1

Striscia di gomma - a freddo
Chemical cure stripping stock
Bande en caoutchouc a 'froid

Codice Code Code	Descrizione Description Description	misure mm / inc Size mm / inches Dimension mm / inches	Peso kg / libre Roll Weight kg / lbs Poids kg / lbs	Pz. / scatola Pcs. / box Pcs. / boîte
T-854BX	Gray Chemical Gum	0.4 x 25 / 1/64 x 1	0.5 / 1	5

italmatic®

GROUP

italmatic®
ACCESSORIES TPMS & EQUIPMENT

italmatic®
ROBOTICS & AGV

italmatic®
AUTOCLAVES OVENS & ROLLERS

giga+
AUTOMATION & SERVICE

TESCO ITALMATIC LLC
OAKLAND PARK - FLORIDA - USA

06

GEMATIC AUTOMOTIVE GMBH
MONTABAUR - GERMANY

05

01

ITALMATIC SRL
CASSINA DE PECCHI - MILANO - ITALY

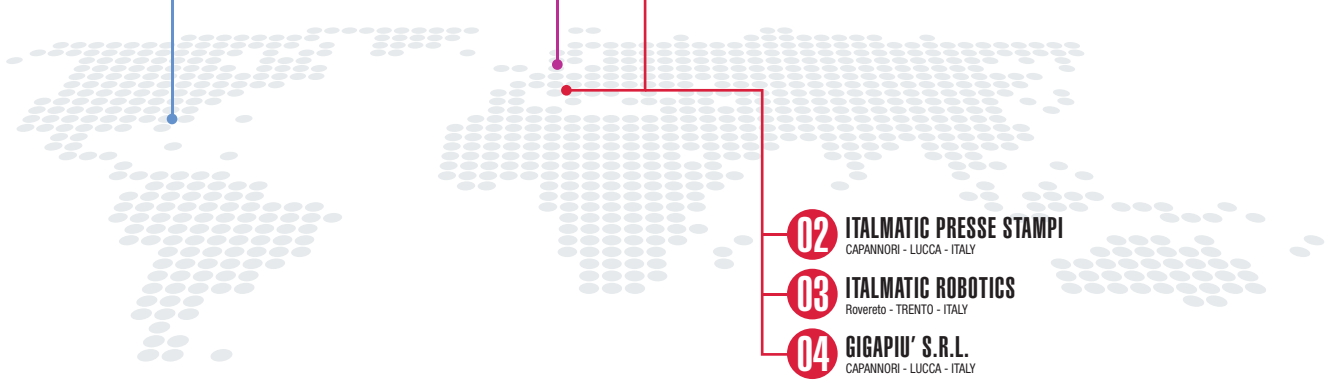

02

ITALMATIC PRESSE STAMPI
CAPANNORI - LUCCA - ITALY

03

ITALMATIC ROBOTICS
ROVERETO - TRENTO - ITALY

04

GIGAPIU' S.R.L.
CAPANNORI - LUCCA - ITALY

HEAD OFFICE & PRODUCTION PLANTS:

01

ITALMATIC S.R.L.
Via dell'Artigianato, 8A
20051 Cassina de' Pecchi (MI) - ITALY
Tel.: +39 02 95300545
mail@italmatic.net

02

ITALMATIC PRESSE STAMPI S.R.L.
Via Tazio Nuvolari 38
55061 Frazione Carraia - Capannori (LU) - ITALY
Tel.: +39 0583 981166
mail@italmatic.net

03

ITALMATIC ROBOTICS
Viale Caproni 11
38068 Rovereto (TN) - ITALY
Tel.: +39 0464 466331
mail@italmatic.net

04

GIGAPIU' S.R.L.
Via Tazio Nuvolari 40
55061 Frazione Carraia - Capannori (LU) - ITALY
Tel.: +39 0583 495831
info@gigapiu.it

SUBSIDIARIES:

05

Gematic Automotive GmbH
Aubachstrasse 3-5
56410 Montabaur (Germany)
tel.: +49 (0) 2602-916 84-0
fax: +49 (0) 2602-916 84-16
www.gematic-automotive.de

06

Tesco-Italmatic LLC
1034 N.E.44th St.
Oakland Park, FL 33334 (USA)
tel.: +1 (800) 377-3329
fax: +1 (954) 565-5602
www.tescoofamerica.com

www.italmatic.group

