



领先的不锈钢加工技术 Leading Stainless Steel Processing Technology

哈雷采用领先行业的不锈钢分水器材加工技术，主管选用高品质的 304 不锈钢材料，比铜制分水器材更加节约原材料，性价比更高。利用先进的冲孔，收口、清洗、抛光等工艺精加工一次成型。主管壁厚高达 1.5mm，分管接口直接在主管上经罗纹攻丝而成，避免了传统焊接工艺的种种弱点，保证哈雷不锈钢分水器材主管更好的密封性和耐压性。另外，不锈钢制分水器材更是杜绝了传统铜制分水器材容易出现的铜锈腐蚀，退色、寿命短等缺点。具有配水稳定、轻便美观、无二次污染等优点，并且机械强度高，耐压、耐腐蚀、耐候性能好、使用寿命长，与居室装修和谐共存，是国际分水器材行业未来发展的方向。

Hrale uses leading stainless steel manifold processing technology and chooses high-quality stainless steel 304 as material for the manifold bars. Compared with copper manifold, stainless steel one has higher cost performance. Hrale uses advanced punching, shrinking, cleaning, polishing and other processes to realize one-step shaping. The wall thickness of the manifold bars is 1.5mm and branch connectors are tapped directly on the bars. In this way, the disadvantages of traditional craft can be avoided to make sure the better tightness and pressure resistance. In addition, stainless steel manifold prevents the weakness of rust corrosion, fading and short life, which are common in traditional copper manifold. On the contrary, it has the advantages of stable water distributing, nice shape, no secondary pollution, high mechanical strength, anti-pressure, anti-corrosion and longer life. This kind of manifold can get well along with the house decoration and will be the direction of the international manifold's development.

- 304 高品质不锈钢材料
- 表面高度抛光
- 一次成型冲孔分管罗纹
- 45°和 90°两端斜度精准工艺
- 1.5mm 坚固厚度
- 精密冲压收口工艺
- 内置高密封性螺帽
- G-1" G-1 1/4" 两端口径选择
- High quality material stainless steel 304
- Highly polished surface
- One-step shaping and branches tapping
- Precision processed two ends gradient
- Strong wall thickness 1.5mm
- Precision two ends shrinking process
- Built-in high-sealing nuts
- G1" and G1 1/4" two size choices

业界领先的 不锈钢加工技术 Leading Stainless Steel Processing Technology



Hrale 哈雷 | 享誉全球的
换热系统解决方案供应商

宁波市哈雷换热设备有限公司
Ningbo Hrale Plate Heat Exchanger Co., Ltd.

地址：浙江省宁波市奉化区滨海新区滨海路 98 号
ADD: No.98, Binwan Road, Binhai New Area, Fenghua, Ningbo, China

电话 (TEL): 86-574-8866 1155 传真 (FAX): 86-574-8891 6955
E-mail: sunxg@hrale.com Website: www.hrale.com



For more information,
please visit our website:
更多信息，请访问我们的网站：

www.hrale.com

STAINLESS STEEL MANIFOLD BARS

World-renowned Supplier of
Heat Exchanger System Solution



www.hrale.com



Hrale 哈雷

不锈钢分水器主管 - FX 型

Stainless Steel Manifold Bar - FX Type

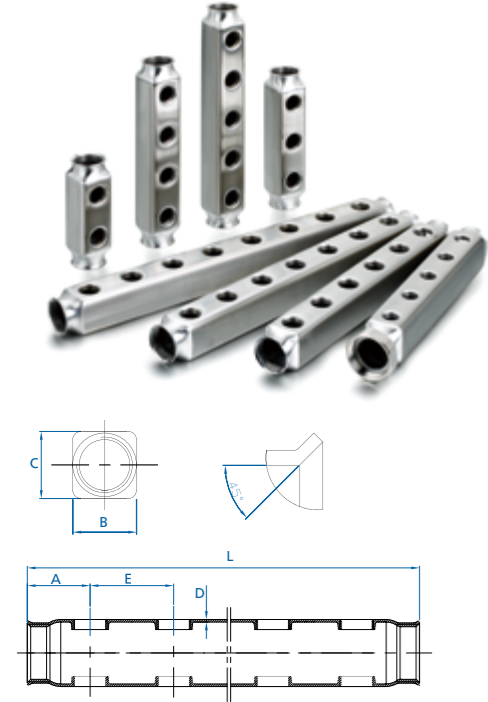

规格型号 Model #	FX-D1	FX-Z2	FX-X3
材质 Material	SUS304	SUS304	SUS304
两端口径 Diameter of ends	G-1 1/4"	G-1"	G-1"
分路口径 Diameter of branches	1/2"	1/2"	1/2"
分路间距 (E) Distance between branches	50mm	50mm	50mm
两端斜度 Gradient of ends	45°	45°	45°
路数 Ways	总长 Length(mm)		
L-2	125	125	125
L-3	175	175	175
L-4	225	225	225
L-5	275	275	275
L-6	325	325	325
L-7	375	375	375
L-8	425	425	425
L-9	475	475	475
L-10	525	525	525
L-11	575	575	575
L-12	625	625	625
L-13	675	675	675
A	37.5	37.5	37.5
B	48.8	40	40.5
C	50	40.7	36.5
D	1.5	1.5	1.5

不锈钢分水器主管 - YX 型

Stainless Steel Manifold Bar - YX Type

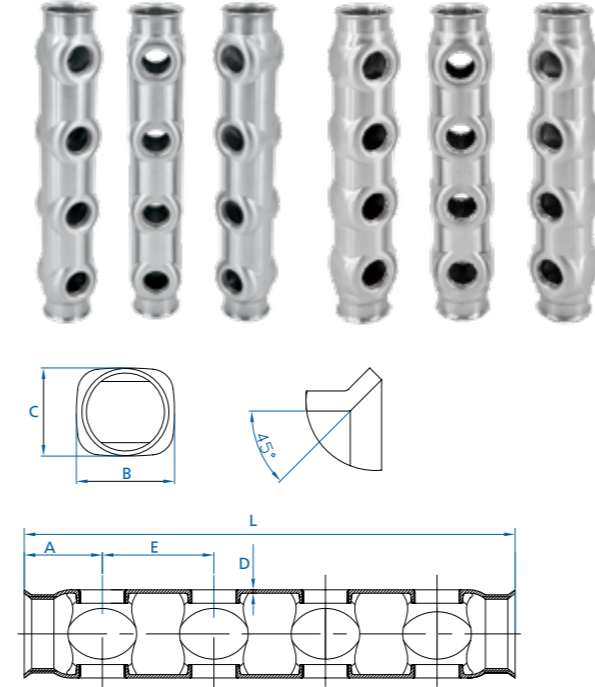

规格型号 Model #	YX-A1	YX-B2
材质 Material	SUS304	SUS304
两端口径 Diameter of ends	G-1"	G-1"
分路口径 Diameter of branches	1/2"	1/2"
分路间距 (E) Distance between branches	60mm	50mm / 55mm
两端斜度 Gradient of ends	45°	45°
路数 Ways	总长 Length(mm)	
L-2	135	120
L-3	195	170
L-4	255	220
L-5	315	270
L-6	375	320
L-7	435	370
L-8	495	420
L-9	555	470
L-10	615	520
L-11	675	570
L-12	735	620
L-13	795	670
A	34.5	35
B	40	44.5
C	39.5	39.5
D	1.5	1.5

支架组件 - ZJ 型

Bracket - ZJ Type

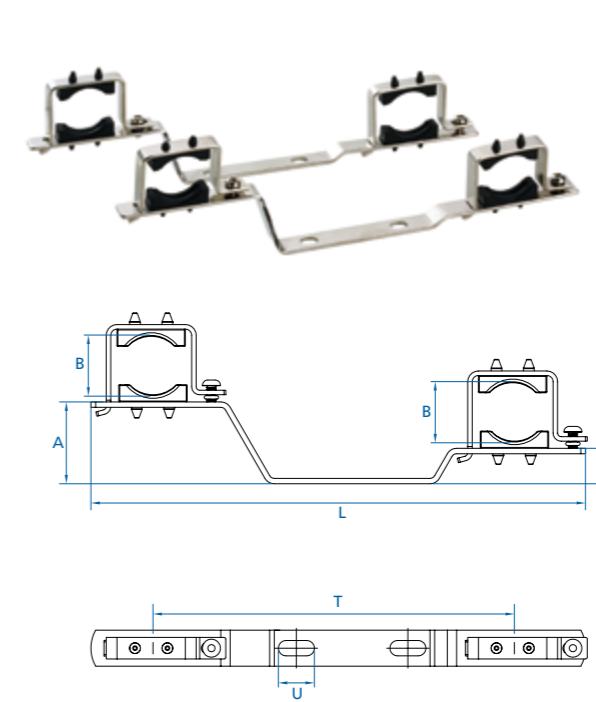

规格型号 Model #	ZJ-N1	ZJ-N2
材质 Material	碳钢 Carbon steel	碳钢 Carbon steel
表面处理 Surface treatment	镀锌 Zinc Plated	镀锌 Zinc Plated
A	45	26
B	40	34
E	20	10
L	304	275
T	230	200
U	20	20

不锈钢分水器主管 - GX 型

Stainless Steel Manifold Bar - GX Type

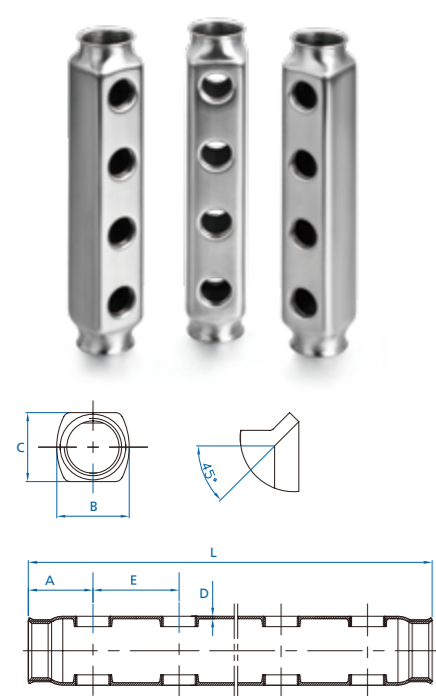

规格型号 Model #	GX-D1	GX-Z2	GX-X3
材质 Material	SUS304	SUS304	SUS304
两端口径 Diameter of ends	G-1 1/4"	G-1"	G-1"
分路口径 Diameter of branches	1/2"	1/2"	1/2"
分路间距 (E) Distance between branches	50mm	50mm	50mm
两端斜度 Gradient of ends	45°	45°	45°
路数 Ways	总长 Length(mm)		
L-2	125	125	125
L-3	175	175	175
L-4	225	225	225
L-5	275	275	275
L-6	325	325	325
L-7	375	375	375
L-8	425	425	425
L-9	475	475	475
L-10	525	525	525
L-11	575	575	575
L-12	625	625	625
L-13	675	675	675
A	37.5	36.5	45
B	47	42.8	41.5
C	47	40.4	36.3
D	1.5	1.5	1.5

不锈钢分水器主管 (带螺帽) - HJ 型

Stainless Steel Manifold Bar - HJ Type

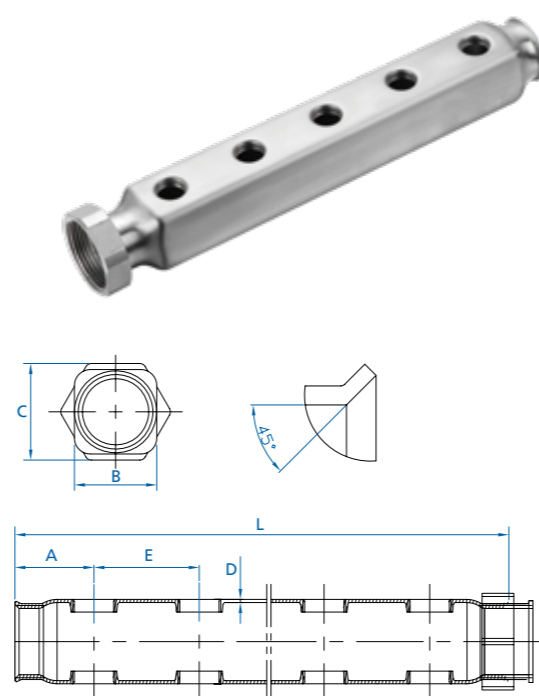

规格型号 Model #	HJ-D1
材质 Material	SUS304
两端口径 Diameter of ends	G-1", G-1 1/4"
分路口径 Diameter of branches	1/2" 3/8"
分路间距 (E) Distance between branches	50mm / 55mm
两端斜度 Gradient of ends	45° / 90°
路数 Ways	总长 Length(mm)
L-2	135
L-3	185
L-4	235
L-5	285
L-6	335
L-7	385
L-8	435
L-9	485
L-10	535
L-11	585
L-12	635
L-13	685
A	37.2
B	41
C	41
D	1.5

不锈钢耦合罐 - OH 型

Stainless Steel Water Mixer - OH Type

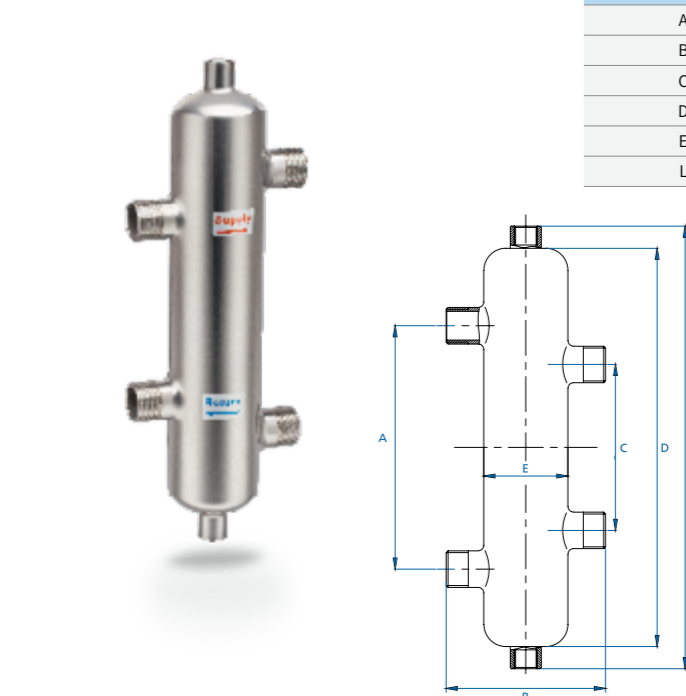

规格型号 Model #	OH-D1	OH-Z2	OH-X3
材质 Material	SUS304	SUS304	SUS304
A	258	238	220
B	208	175	144
C	258	238	150
D	525	390	360
E	133	103	76
L	575	535	400