

GÜÇLÜ BİR GELECEK İÇİN STRONGER FOR THE FUTURE



www.activent.com.tr



ACTIVENT®

ÜRÜN KATALOĞU
PRODUCT CATALOGUE



RADYAL FANLAR
RADIAL FANS

RADYAL FAN YÖNLERİ RADIAL FAN DIRECTIONS

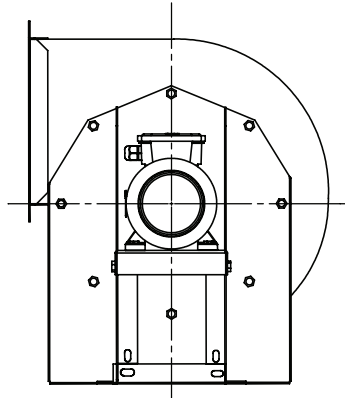

L180

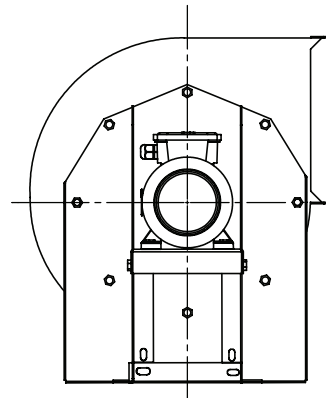

R180

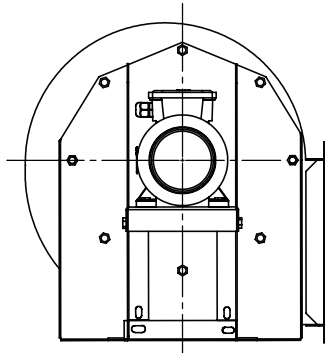

L270

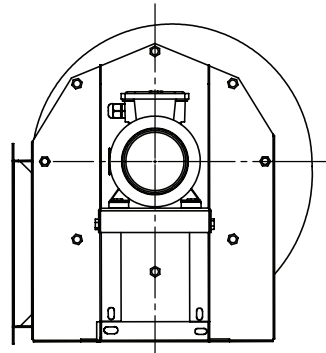

R270

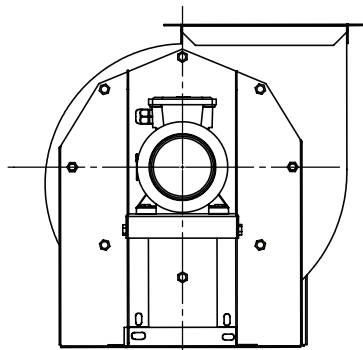

L090

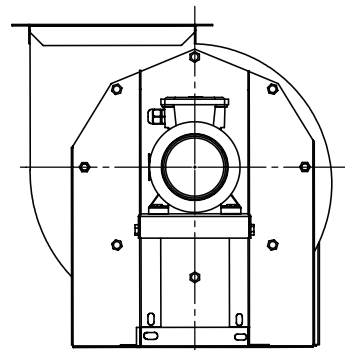

R090

3 RADYAL FANLAR RADIAL FANS

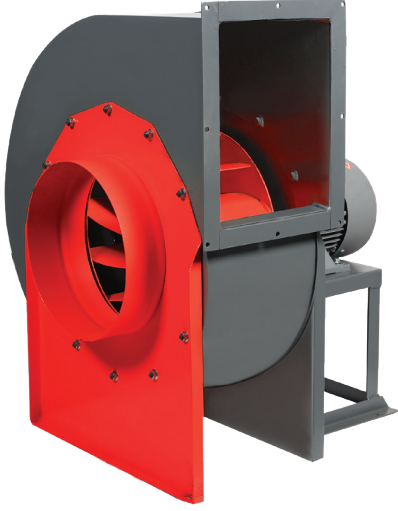

RALR

ÖNE EĞİMLİ VE SEYREK KANATLI
DİREKT AKUPLE TEK EMİŞLİ RADYAL FANLAR
ALÇAK BASINÇLI

SINGLE SUCTION, INDUSTRIAL RADIAL FANS
(FORWARD CURVED) SPARSE WING
LOW PRESSURE

RALR alçak basınç sistemleri için tasarlanmış bu fanlar her türlü tesis havalandırmasında kullanılabilirler. Vidalı montaj sistemi sayesinde kasa istenen atış pozisyonuna rahatlıkla çevrilebilirler. En ekonomik havalandırma çözümlerinden biridir. Kanat yapısı seyrek oluşu sayesinde pervane temizliği kolaydır.

MALZEME

Kompleksi elektrostatik toz boyalı DKP siyah sacdan üretilmiştir. Radyal fan, öne eğimli seyrek kanat yapısı ile DKP siyah sacdan üretilmiştir.

HIZ KONTROLÜ

Opsiyonel olarak frekans inverteri ile sağlanabilirler.

KULLANIM ALANLARI

Fırınlarda, çeşitli ısıtma-havalandırma ve titreşimin istenmediği düşük çalışma hızlarının kullanıldığı elektronik ve benzeri ekipmanların soğutulmasında kullanılır. Talep üzerine imalat ve montajda kolaylık sağlayan kare gövdeli fan imalatı da mevcuttur.

RALR low pressure systems. These fans designed for all kinds in plant ventilation they can be used. Screw mounting. Thanks to the system, the desired safe comfortably into the shooting position they can be translated. The most economical from ventilation solutions is one. The wing structure is sparse thanks to propeller cleaning is easy.

MATERIAL

The assembly is electrostatic powder coated DKP. It is made of black sheet. Radial fan, forward DKP black with curved sparse propeller structure. Made of sheet metal.

SPEED CONTROL

Optionally with frequency inverter they can be provided.

USAGE AREAS

Various heating-ventilation and low running where vibration is undesirable electronics and the like using speeds. It is used for the cooling of equipment. Convenience in manufacturing and assembly upon request. Manufacture of square-bodied fan that provides.

Tip/Kod Type/Code	Elektrik Motoru / Electrical Motor				Max. Debi Air Flow m ³ / h	Max. Basınç Kaybı Pressure Pa
	Voltaj Voltage	Güç Power		Devir Speed		
	(V)	(HP)	(kW)	(d/d) (rpm)		
RALR-0,50-T-4K	380	0,50	0,37	1.380	2.000	400
RALR-1,00-T-4K	380	1,00	0,75	1.410	3.500	500
RALR-1,50-T-4K	380	1,50	1,10	1.430	4.500	600
RALR-2,00-T-4K	380	2,00	1,50	1.430	5.500	700
RALR-3,00-T-4K	380	3,00	2,20	1.435	7.000	800
RALR-4,00-T-4K	380	4,00	3,00	1.435	8.000	900
RALR-5,50-T-4K	380	5,50	4,00	1.455	9.000	1.000
RALR-7,50-T-4K	380	7,50	5,50	1.465	12.000	1.100
RALR-10,0-T-4K	380	10,0	7,50	1.465	14.000	1.200

TEKNİK ÖLÇÜLER / TECHNICAL DIMENSION

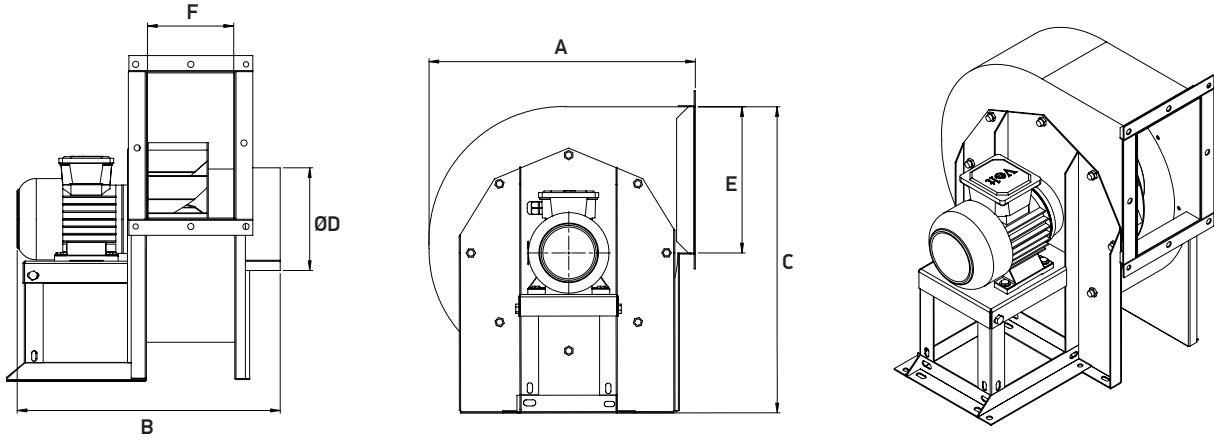

Tip/Kod Type/Code	Ölçüler / Sizes (mm)					
	A	B	C	D	E	F
RALR-0,50-T-4K	470	420	620	Ø 200	250	180
RALR-1,00-T-4K	470	420	620	Ø 200	250	180
RALR-1,50-T-4K	520	490	650	Ø 240	260	200
RALR-2,00-T-4K	570	510	680	Ø 260	280	220
RALR-3,00-T-4K	610	600	715	Ø 320	300	230
RALR-4,00-T-4K	610	610	760	Ø 320	300	250
RALR-5,50-T-4K	630	710	790	Ø 350	360	280
RALR-7,50-T-4K	720	800	880	Ø 350	490	330
RALR-10,0-T-4K	770	850	960	Ø 400	530	380

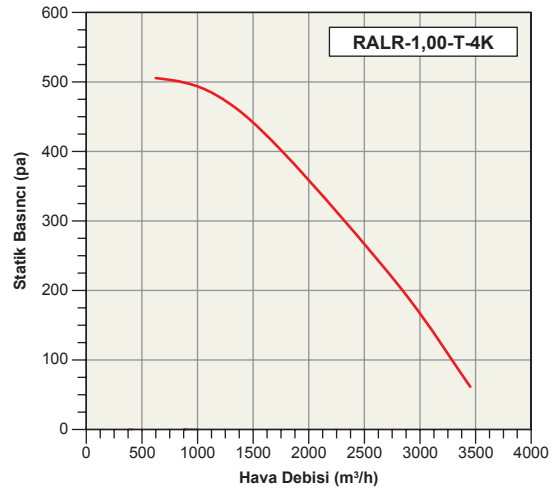
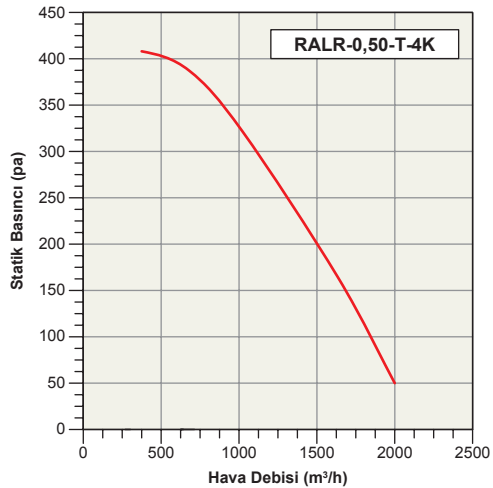

TEKNİK ÖLÇÜLER / TECHNICAL DIMENSION

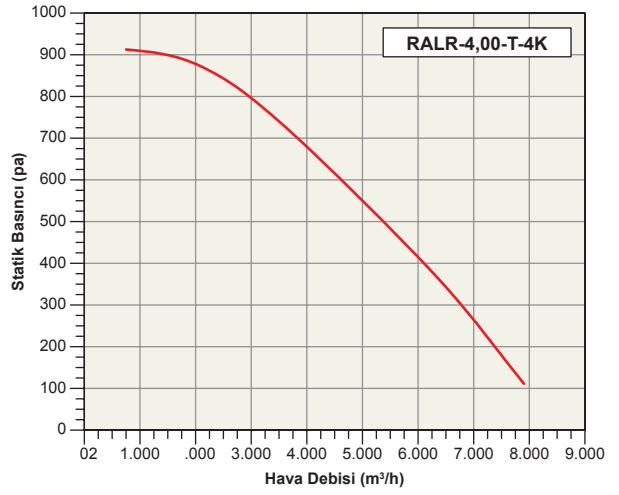
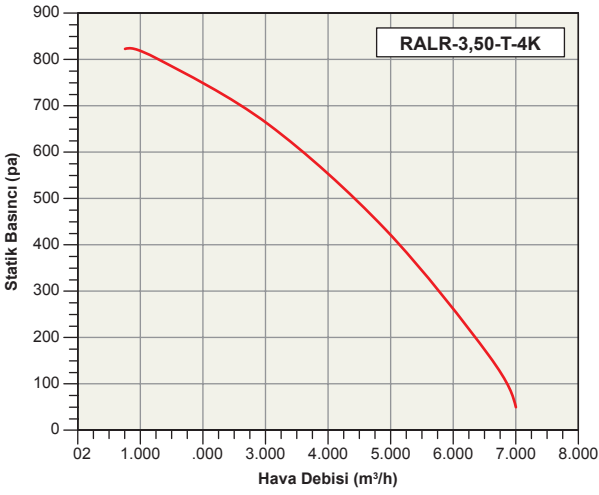
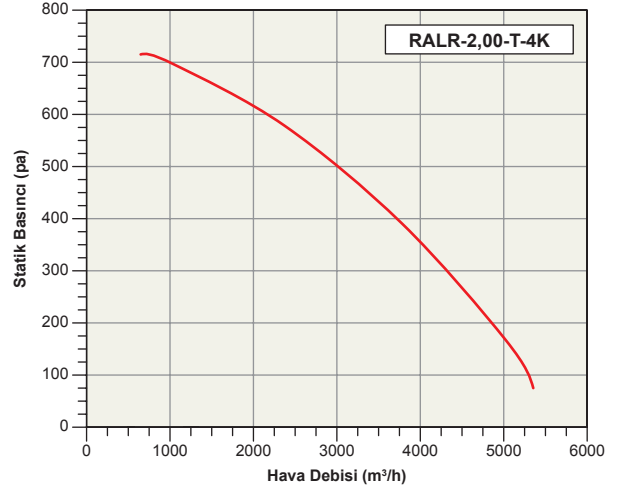
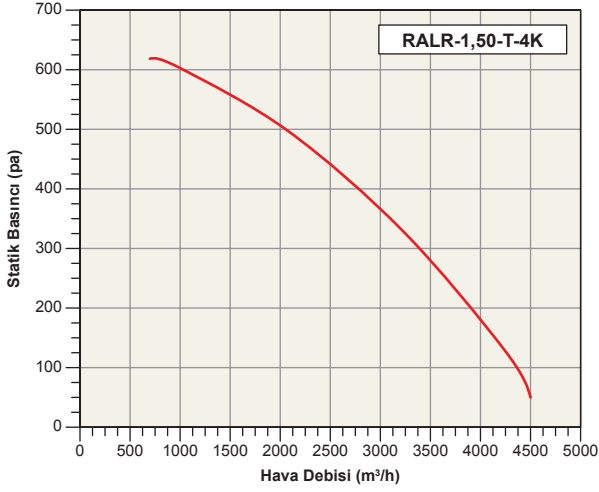

TEKNİK ÖLÇÜLER / TECHNICAL DIMENSION

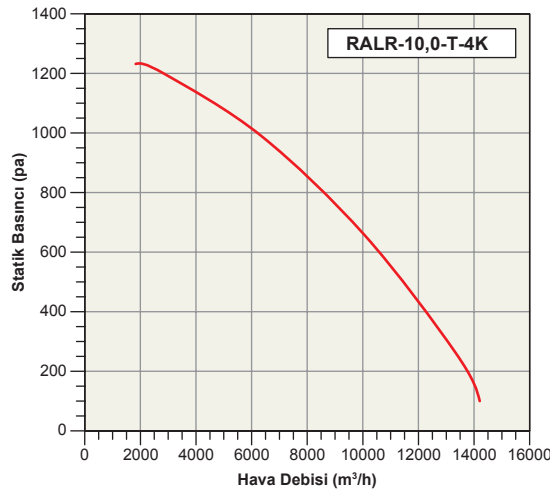
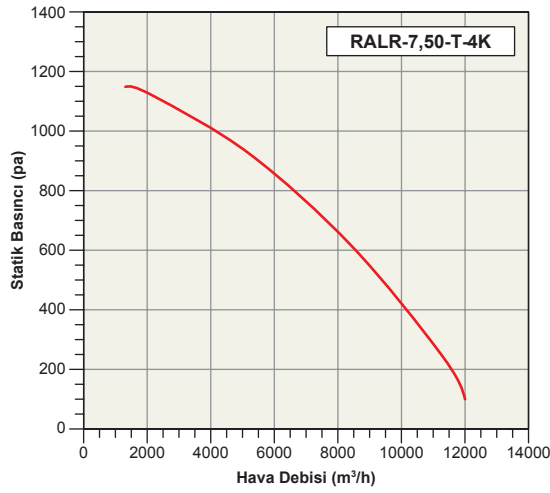
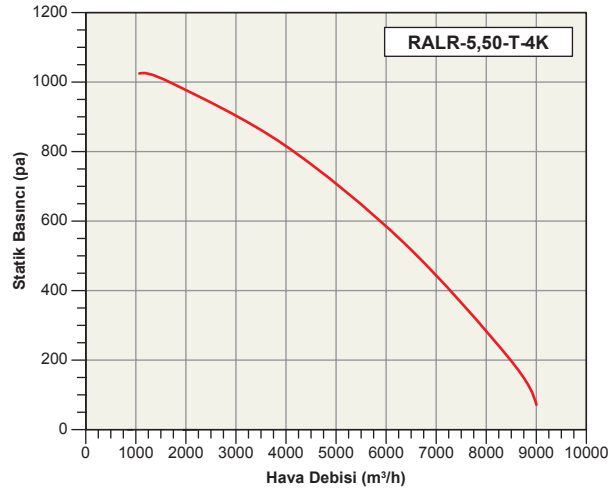

ACTIVENT®

Halkalı Merkez Mahallesi
Şehit Yılmaz Özdemir Caddesi
Sanayi Sokak No: 4
Küçükçekmece, İstanbul, Türkiye

P: +90.212 698 02 25

P: +90.212 698 02 26

P: +90.212 565 73 03

info@activent.com.tr

www.activent.com.tr

