



DAYGAS
heating systems

ABOUT US

Daygas Heat Systems started the production of natural gas-powered heaters, which were established in Istanbul by young entrepreneurs in 2014, providing heating in open and closed areas. Daygas has adopted unconditional customer satisfaction since its foundation.

Daygas cares about innovation and R&D studies, thus saving energy in the heating industry it is a brand that combines efficient, economical, quality and functional products with end consumers.

Our company, which has been serving since 2014, has been producing and selling ceramic radiant heaters, industrial ceramic radiant heaters, hot air generators, pipe type radiant heaters and electric infrared heaters, and after-sales service activities are carried out.

Vision

Minimizing the carbon footprint while producing innovative, technological, economical, quality, functional devices that save energy in the heating industry, and offering friendly products to the use of people.

Mission

To produce economical, quality, innovative, environmentally friendly and functional products with the principle of unconditional customer satisfaction.



CONTENTS

06

DSR Ceramic Radiant Heaters

13

Lodos Hot Air Generators

18

Radium Pipe Type Radiant Heaters

25

Solis Electric Heaters

27

Accessories

28

Control Units





High standards temperature

Daygas Radiant Heating Systems are high efficiency heating technologies that convert the energy obtained from NG, LPG and electricity to heat energy and transfer this energy directly to the desired environment, based on the heating principle of sunlight.

Daygas Radiant Heating Systems transmit the energy obtained from NG, LPG and electricity to the environment where it is located, and has the widest radiation ability. Thanks to its specially designed combustion surface, it provides superiority compared to other radiant products with its high efficiency and low energy consumption. It is simple to set up and use, reducing costs. Dimensions and ergonomic Thanks to their designs, they are compatible with the architectural structures of the areas of use.

Daygas Radiant Heat Systems are suitable for use in cafes, restaurants, winter gardens, factories, warehouses, antrepos, gyms and stadiums, places of worship, greenhouses and all open, semi-open or sufficiently ventilated enclosed spaces. In addition, the project can be developed according to the demand and designed according to the specific use purposes.

Daygas Radiant Heating Systems manual, with remote control or other Daygas control units controllable. It can be produced steplessly, in 2 stages and in 5 stages. You can control all Daygas heating products with one control.

All Daygas branded products use premium CE documented materials. Metal parts of products It is resistant to corrosion and can be used easily by the sea and in damp environments.





Daygas Radiant Heating Systems are high efficiency heating technologies that convert the energy obtained from NG, LPG and electricity to heat energy and transfer this energy directly to the desired environment, based on the heating principle of sunlight.

It must be a regulator for devices with LPG and must be at a maximum distance of 2m from the device.

DSR Premium Series / Plus

Technical Specifications

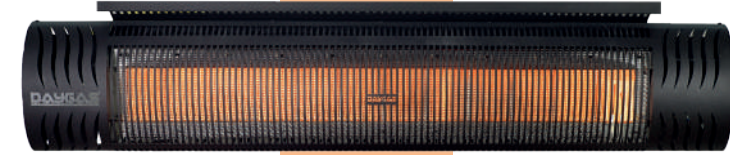
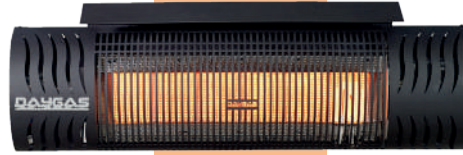

	DSR 6 Premium Series / Plus	DSR 10 Premium Series / Plus	DSR 12 Premium Series / Plus	DSR 18 Premium Series / Plus	DSR 25 Premium Series / Plus
Capacity	6 kW	9 kW	12 kW	18 kW	25 kW
Gas Consumption	NG 0,384-0,64m ³ /h / LPG 0,282-0,47kg/h	NG 0,57-0,95m ³ /h / LPG 0,42-0,70kg/h	NG 0,762-1,27m ³ /h / LPG 0,57-0,95kg/h	NG 1,14-1,90m ³ /h / LPG 0,846-1,41kg/h	NG 1,06-2,65m ³ /h / LPG 0,784-1,96kg/h
Dimensions (Mm)	270h / 780L / 225w	270h / 960L / 225w	270h / 960L / 225w	270h / 1505L / 225w	270h / 1505L / 225w
Weight (Kg)	Net 13,35kg / Gross 14,75kg	Net 15,50kg / Gross 17,15kg	Net 15,50kg / Gross 17,15kg	Net 30,55kg / Gross 33,1kg	Net 30,55kg / Gross 33,1kg
Usage Pressure	21-55mbr NG / 32-55mbr LPG	21-55mbr NG / 32-55mbr LPG	21-55mbr NG / 32-55mbr LPG	21-55mbr NG / 32-55mbr LPG	21-55mbr NG / 32-55mbr LPG
Heating Area M²	min 9m ² / Avg 15m ² / max 20m ²	min 12m ² / Avg 20m ² / max 30m ²	min 18m ² / Avg 25m ² / max 40m ²	min 25m ² / Avg 30m ² / max 50m ²	min 30m ² / Avg 35m ² / max 55m ²
Empty Space Sound	16 d-BA	16 d-BA	16 d-BA	16 d-BA	16 d-BA
Working Environment Sound	12 d-BA	12 d-BA	12 d-BA	12 d-BA	12 d-BA
Stage	Standard 2 / Plus 5	Standard 2 / Plus 5	Standard 2 / Plus 5	Standard 2 / Plus 5	Standard 2 / Plus 5
Ceramic Plate	4 Pieces	6 Pieces	6 Pieces	12 Pieces	12 Pieces
Electrical Connection	230-240VAC 50-60 Hz +/-%15	230-240VAC 50-60 Hz +/-%15	230-240VAC 50-60 Hz +/-%15	230-240VAC 50-60 Hz +/-%15	230-240VAC 50-60 Hz +/-%15
Gas Connection	G 3/4"	G 3/4"	G 3/4"	G 3/4"	G 3/4"
Installation Height	180-300cm	185-350cm	190-350cm	210-450cm	220-450cm
Box Dimensions	300h / 820L / 300w	300h / 1010L / 300w	300h / 1010L / 300w	300h / 1560L / 300w	300h / 1560L / 300w
Electricity Consumption	10,3 w/h	10,3 w/h	10,3 w/h	10,3 w/h	10,3 w/h



For Daygas DSR model devices, the natural gas working pressure is 21 mbar, and the working pressure at maximum efficiency is recommended as 35 mbar. All natural gas devices with recommended pressure values in the environment are running (cooker, oven etc) should be measured from the closest location to the device, the regulators to be installed should be at a maximum distance of 2 meters from the device.



DSR LCD Series / Plus

Technical Specifications

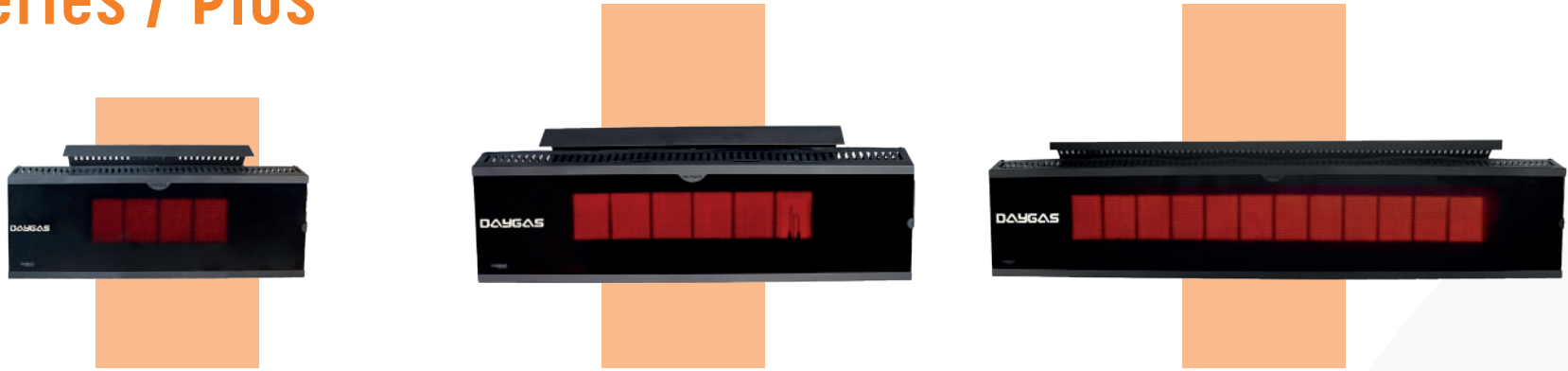

	DSR 6 LCD Series / Plus	DSR 10 LCD Series / Plus	DSR 12 LCD Series / Plus	DSR 18 LCD Series / Plus	DSR 25 LCD Series / Plus
Capacity	6 kW	9 kW	12 kW	18 kW	25 kW
Gas Consumption	NG 0,384-0,64m ³ /h / LPG 0,282-0,47kg/h	NG 0,57-0,95m ³ /h / LPG 0,42-0,70kg/h	NG 0,762-1,27m ³ /h / LPG 0,57-0,95kg/h	NG 1,14-1,90m ³ /h / LPG 0,846-1,41kg/h	NG 1,06-2,65m ³ /h / LPG 0,784-1,96kg/h
Dimensions (Mm)	270h / 780L / 225w	270h / 960L / 225w	270h / 960L / 225w	270h / 1505L / 225w	270h / 1505L / 225w
Weight (Kg)	Net 16,40kg / Gross 17,8kg	Net 18,80kg / Gross 20,45kg	Net 18,80kg / Gross 20,45kg	Net 38,05kg / Gross 40,06kg	Net 38,05kg / Gross 40,06kg
Usage Pressure	21-55mbr NG / 32-55mbr LPG	21-55mbr NG / 32-55mbr LPG	21-55mbr NG / 32-55mbr LPG	21-55mbr NG / 32-55mbr LPG	21-55mbr NG / 32-55mbr LPG
Heating Area M²	min 7,65m ² / Avg 12,75m ² / max 17m ²	min 11,8m ² / Avg 17m ² / max 25,5m ²	min 15,3m ² / Avg 21,25m ² / max 34m ²	min 21,25m ² / Avg 25,5m ² / max 42,5m ²	min 25,5m ² / Avg 30m ² / max 46,5m ²
Empty Space Sound	16 d-BA	16 d-BA	16 d-BA	16 d-BA	16 d-BA
Working Environment Sound	12 d-BA	12 d-BA	12 d-BA	12 d-BA	12 d-BA
Stage	Standard 2 / Plus 5	Standard 2 / Plus 5	Standard 2 / Plus 5	Standard 2 / Plus 5	Standard 2 / Plus 5
Ceramic Plate	4 Pieces	6 Pieces	6 Pieces	12 Pieces	12 Pieces
Electrical Connection	230-240VAC 50-60 Hz +/-%15	230-240VAC 50-60 Hz +/-%15	230-240VAC 50-60 Hz +/-%15	230-240VAC 50-60 Hz +/-%15	230-240VAC 50-60 Hz +/-%15
Gas Connection	G 3/4"	G 3/4"	G 3/4"	G 3/4"	G 3/4"
Installation Height	180-300cm	185-350cm	190-350cm	210-450cm	220-450cm
Box Dimensions	300h / 820L / 300w	300h / 1010L / 300w	300h / 1010L / 300w	300h / 1560L / 300w	300h / 1560L / 300w
Electricity Consumption	10,3 w/h	10,3 w/h	10,3 w/h	10,3 w/h	10,3 w/h

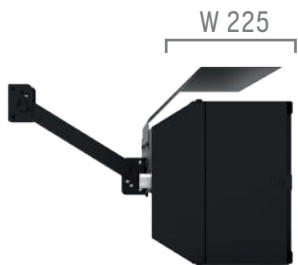

For Daygas DSR model devices, the natural gas working pressure is 21 mbar, and the working pressure at maximum efficiency is recommended as 35 mbar. All natural gas devices with recommended pressure values in the environment (cooker, oven etc) should be measured from the closest location to the device, the regulators to be installed should be at a maximum distance of 2 meters from the device.



Same Quality Temperature At Every Angle

By positioning DAYGAS heater types in different places, you can reach the temperature you want in your area at any time of the day.



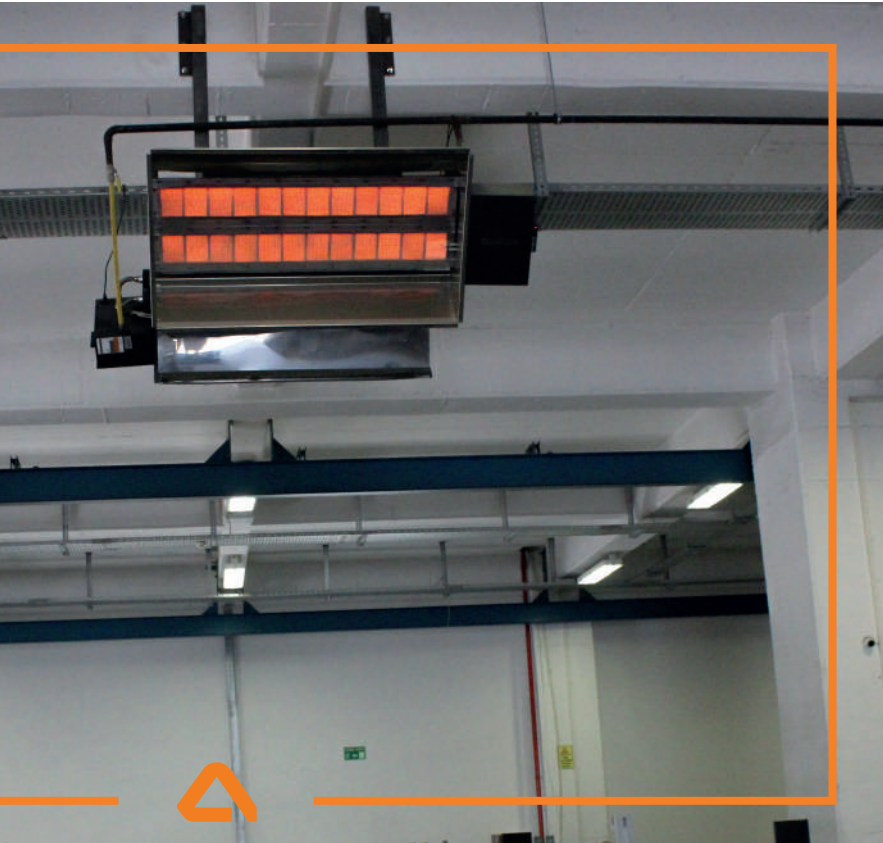

	DSR 25 Industrial	DSR 30 Industrial
Capacity	25 kW	30 kW
Gas Consumption	NG 1,06-2,65m ³ /h / LPG 0,784-1,96kg/h	NG 1,902-3,17m ³ /h / LPG 1,41-2,35 kg/h
Dimensions (Mm)	515h / 1440L / 410w	515h / 1440L / 410w
Weight (Kg)	Net 31,80kg / Gross 36,60kg	Net 31,80kg / Gross 36,60kg
Usage Pressure	21-55mbr NG / 32-55mbr LPG	21-55mbr NG / 32-55mbr LPG
Heating Area M²	min 35m ² / Avg 40m ² / max 60m ²	min 40m ² / Avg 50m ² / max 70m ²
Empty Space Sound	18 d-BA	18 d-BA
Working Environment Sound	14 d-BA	14 d-BA
Stage	Standard 2 / Plus 5	Standard 2 / Plus 5
Ceramic Plate	12 Pieces	12 Pieces
Electrical Connection	230-240VAC 50-60 Hz +/-%15	230-240VAC 50-60 Hz +/-%15
Gas Connection	G 3/4"	G 3/4"
Installation Height	180-300cm	180-300cm
Box Dimensions	550h / 1470L / 450w	550h / 1470L / 450w
Electricity Consumption	10,3 w/h	10,3 w/h

For Daygas DSR model devices, the natural gas working pressure is 21 mbar, and the working pressure of 35 mbar is recommended at maximum efficiency. All natural gas devices with recommended pressure values in the environment are running (stove, oven, etc.), should be measured from the closest place to the device, the regulators to be installed should be at a maximum distance of 2 meters from the device.

DSR Industrial / Plus

Technical Specifications

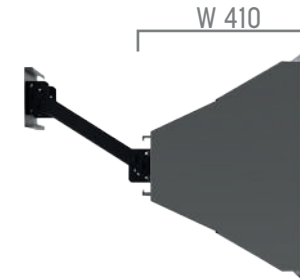
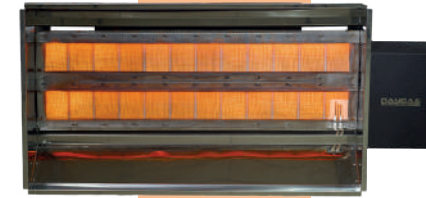

	DSR 35-36 Industrial	DSR 38-40 Industrial	DSR 50 Industrial	DSR 56 Industrial
Capacity	35-35,5 kW	38-38,5 kW	48 kW	56 kW
Gas Consumption	NG 2,25-3,75m ³ /h / LPG 1,674-2,79kg/h	NG 2,538-4,23m ³ /h / LPG 1,894-3,14kg/h	NG 3,06-5,10m ³ /h / LPG 2,262-3,77kg/h	NG 3,552-5,92m ³ /h / LPG 2,64-4,40kg/h
Dimensions (Mm)	515h / 1440L / 410w	710h / 1440L / 410w	710h / 1440L / 410w	710h / 11440L / 410w
Weight (Kg)	Net 31,80kg / Gross 36,60kg	Net 51,85kg / Gross 58,03kg	Net 51,85kg / Gross 58,3kg	Net 51,85kg / Gross 58,3kg
Usage Pressure	21-55mbr NG / 32-55mbr LPG	21-55mbr NG / 32-55mbr LPG	21-55mbr NG / 32-55mbr LPG	21-55mbr NG / 32-55mbr LPG
Heating Area M²	min 45m ² / Avg 55m ² / max 75m ²	min 55m ² / Avg 65m ² / max 90m ²	min 56m ² / Avg 67m ² / max 94m ²	min 80m ² / Avg 100m ² / max 135m ²
Empty Space Sound	18 d-BA	18 d-BA	18 d-BA	18 d-BA
Working Environment Sound	14 d-BA	14 d-BA	14 d-BA	14 d-BA
Stage	Standard 2 / Plus 5	Standard 2 / Plus 5	Standard 2 / Plus 5	Standard 2 / Plus 5
Ceramic Plate	12 Pieces	24 Pieces	24 Pieces	24 Pieces
Electrical Connection	230-240VAC 50-60 Hz +/-%15	230-240VAC 50-60 Hz +/-%15	230-240VAC 50-60 Hz +/-%15	230-240VAC 50-60 Hz +/-%15
Gas Connection	G 3/4"	G 3/4"	G 3/4"	G 3/4"
Installation Height	270-550cm	300-900cm	330-1000cm	350-1200cm
Box Dimensions	550h / 1470L / 450w	550h / 1470L / 450w	730h / 1470L / 450w	730h / 1470L / 450w
Electricity Consumption	10,3 w/h	10,3 w/h	10,3 w/h	10,3 w/h

For Daygas DSR model devices, the natural gas working pressure is 21 mbar, and the working pressure of 35 mbar is recommended at maximum efficiency. All natural gas devices with recommended pressure values in the environment are running (stove, oven, etc.), should be measured from the closest place to the device, the regulators to be installed should be at a maximum distance of 2 meters from the device.

DSR Ceramic Radiant Heaters

Specially designed Daygas ceramic stone with high luminosity, effective and economical power in local heating solutions.

- >>Technology from the sun.
- >>All metal parts are resistant to high temperatures and long-lasting.
- >>All electrical parts consist of high heat resistant fireproof silicone cables.

Ceramic Stones

Specially produced Daygas ceramic stones are used in Daygas ceramic radiant devices. The radiant wavelength must be in the infrared range. Stone selection and quality are very important as radiation occurs from the ceramic stone surface area in line with these desired conditions.

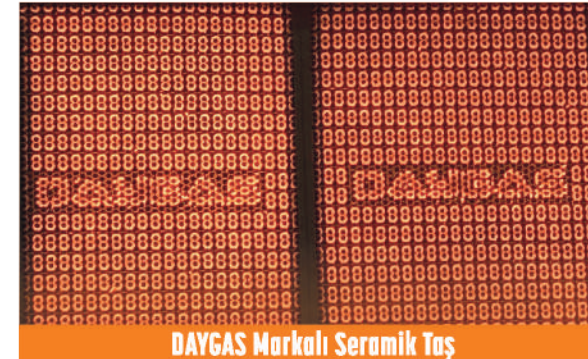

DAYGAS Markalı Seramik Taş

Lodos Hot Air Generators

The heat energy that Daygas Lodos hot air generators obtained from NG or LPG, Thanks to the fan on it, it is the devices that provide heating by blowing hot air directly or with air ducts to the desired environment. Daygas Lodos hot air generator devices provide high efficiency and low energy consumption thanks to the specially designed boiler structure. It is the product with the lowest working sound in its class with its special design boiler and body structure. It works quieter than its counterparts. Due to the rise of warm air, it is recommended to use hot air generators in closed areas where the ceiling height does not exceed 5m in order to provide more efficient and homogeneous heating..

Features Of Lodos Hot Air Generators

- >> Possibility to operate with remote control 5-stage or thermostat
- >> Step and fault notification image on display screen
- >> Increased efficiency thanks to the special design boiler structure and winged serpentes
- >> High level of safety
- >> Safe gas valve system
- >> Quick start up
- >> Low energy consumption
- >> Low emission rate
- >> Quiet operation
- >> Cooling mode

Lodos breeze in the winter cold,

Refreshing pleasure in hot weather.

- >> All metal parts are high-temperature resistant, long-lasting aluminum-silicon alloy.
- >> All electrical components consist of fireproof silicone cables that are resistant to high temperatures.
- >> Possibility of working hermetically and semi-hermetically.



Lodos Series

Technical Specifications

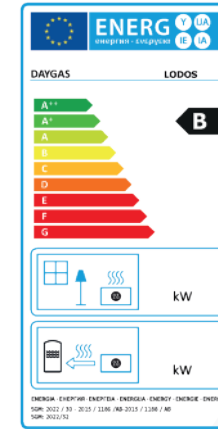

	Lodos 16	Lodos 20	Lodos 25
Capacity	16 kW	20 kW	25 kW
Gas Consumption	NG 0,912-1,52m ³ /h / LPG 0,672-1,12kg/h	NG 1,14-1,90m ³ /h / LPG 0,846-1,41kg/h	NG 1,428-2,38m ³ /h / LPG 1,056-1,76kg/h
Dimensions (mm)	600h / 525L / 675w	600h / 525L / 675w	600h / 525L / 675w
Weight (kg)	Net 39,00kg / Gross 43,00kg	Net 39,00kg / Gross 43,00kg	Net 39,00kg / Gross 43,00kg
Heating Area m²	min 80m ² / Avg 100m ² / max 120m ²	min 100m ² / Avg 125m ² / max 150m ²	min 120m ² / Avg 150m ² / max 180m ²
Heating Area m³	min 240m ³ / Avg 300m ³ / max 360m ³	min 300m ³ / Avg 375m ³ / max 450m ³	min 360m ³ / Avg 450m ³ / max 540m ³
Empty Space Sound	50 d-BA	50 d-BA	50 d-BA
Working Environment Sound	39 d-BA	39 d-BA	39 d-BA
Flow (m³)	3300m ³	3300m ³	3300m ³
Electrical Connection	230-240VAC 50-60 Hz +/-0%15	230-240VAC 50-60 Hz +/-0%15	230-240VAC 50-60 Hz +/-0%15
Usage Pressure	21-55mbr NG / 32-55mbr LPG	21-55mbr NG / 32-55mbr LPG	21-55mbr NG / 32-55mbr LPG
Electricity Consumption	411,3 w/h	411,3 w/h	411,3 w/h
Gas Connection	G 3/4"	G 3/4"	G 3/4"
Box Dimensions	610h / 555L / 685w	610h / 555L / 685w	610h / 555L / 685w



Radial Fan Selection: Our devices are suitable for use with duct type and radial fans. You can get information about the subject from your sales consultant.

Axial Fan Selection: Depending on the areas of use, axial fan sizes of Lodos 45-50-55 devices can be optionally changed. You can get information about the subject from your sales consultant.

For Daygas Lodos model devices with a capacity of 16-55 KW, the natural gas operating pressure is 21 mbar, and the maximum efficiency operating pressure is 35 mbar. Recommended pressure values should be measured from the closest point to the device when all natural gas devices in the environment are operating (stove, oven, etc.), and the regulators to be installed should be at a maximum distance of 2 meters from the device.

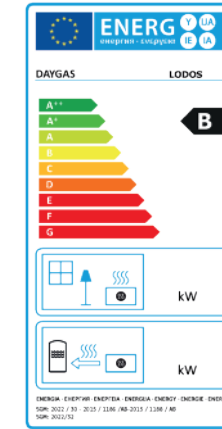

	Lodos 30	Lodos 35	Lodos 40
Capacity	30 kW	35 kW	40 kW
Gas Consumption	NG 1,71-2,85m ³ /h / LPG 1,26-2,11kg/h	NG 1,998-3,33m ³ /h / LPG 1,47-2,46kg/h	NG 2,28-3,8m ³ /h / LPG 1,686-2,81kg/h
Dimensions (mm)	660h / 660L / 820w	660h / 660L / 820w	660h / 660L / 820w
Weight (kg)	Net 49,00kg / Gross 54,00kg	Net 49,00kg / Gross 54,00kg	Net 49,00kg / Gross 54,00kg
Heating Area m²	min 152m ² / Avg 190m ² / max 228m ²	min 176m ² / Avg 220m ² / max 264m ²	min 200m ² / Avg 250m ² / max 300m ²
Heating Area m³	min 456m ³ / Avg 570m ³ / max 684m ³	min 528m ³ / Avg 660m ³ / max 792m ³	min 600m ³ / Avg 750m ³ / max 900m ³
Empty Space Sound	55 d-BA	55 d-BA	55 d-BA
Working Environment Sound	43 d-BA	43 d-BA	43 d-BA
Flow (m³)	3500m ³	3500m ³	3500m ³
Electrical Connection	230-240VAC 50-60 Hz +/-%15	230-240VAC 50-60 Hz +/-%15	230-240VAC 50-60 Hz +/-%15
Usage Pressure	21-55mbr NG / 32-55mbr LPG	21-55mbr NG / 32-55mbr LPG	21-55mbr NG / 32-55mbr LPG
Electricity Consumption	411,3 w/h	411,3 w/h	411,3 w/h
Gas Connection	G 3/4"	G 3/4"	G 3/4"
Box Dimensions	670h / 690L / 830w	670h / 690L / 830w	670h / 690L / 830w



Radial Fan Selection: Our devices are suitable for use with duct type and radial fans. You can get information about the subject from your sales consultant.

Axial Fan Selection: Depending on the areas of use, axial fan sizes of Lodos 45-50-55 devices can be optionally changed. You can get information about the subject from your sales consultant.

For Daygas Lodos model devices with a capacity of 16-55 KW, the natural gas operating pressure is 21 mbar, and the maximum efficiency operating pressure is 35 mbar. Recommended pressure values should be measured from the closest point to the device when all natural gas devices in the environment are operating (stove, oven, etc.), and the regulators to be installed should be at a maximum distance of 2 meters from the device.

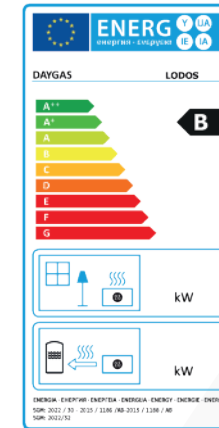

	Lodos 45	Lodos 50	Lodos 55
Capacity	45 kW	50 kW	55 kW
Gas Consumption	NG 2,568-4,28m ³ /h / LPG 1,896-3,16kg/h	NG 2,85-4,75m ³ /h / LPG 2,112-3,52kg/h	NG 3,138-5,23m ³ /h / LPG 2,322-3,87kg/h
Dimensions (mm)	790h / 760L / 820w	790h / 760L / 820w	790h / 760L / 820w
Weight (kg)	Net 73,75kg / Gross 88,60kg	Net 73,75kg / Gross 88,60kg	Net 73,75kg / Gross 88,60kg
Heating Area m²	min 224m ² / Avg 280m ² / max 336m ²	min 250m ² / Avg 300m ² / max 365m ²	min 275m ² / Avg 330m ² / max 395m ²
Heating Area m³	min 672m ³ / Avg 840m ³ / max 1008m ³	min 740m ³ / Avg 930m ³ / max 1100m ³	min 810m ³ / Avg 1020m ³ / max 1208m ³
Empty Space Sound	55 d-BA	55 d-BA	55 d-BA
Working Environment Sound	43 d-BA	43 d-BA	43 d-BA
Flow (m³)	3500m ³	3500m ³	3500m ³
Electrical Connection	230-240VAC 50-60 Hz +/--%15	230-240VAC 50-60 Hz +/--%15	230-240VAC 50-60 Hz +/--%15
Usage Pressure	21-55mbr NG / 32-55mbr LPG	21-55mbr NG / 32-55mbr LPG	21-55mbr NG / 32-55mbr LPG
Electricity Consumption	411,3 w/h	411,3 w/h	411,3 w/h
Gas Connection	G 3/4"	G 3/4"	G 3/4"
Box Dimensions	800h / 790L / 820w	800h / 790L / 820w	800h / 790L / 820w



Radial Fan Selection: Our devices are suitable for use with duct type and radial fans. You can get information about the subject from your sales consultant.



Axial Fan Selection: Depending on the areas of use, axial fan sizes of Lodos 45-50-55 devices can be optionally changed. You can get information about the subject from your sales consultant.

For Daygas Lodos model devices, the natural gas working pressure is 21 mbar for devices with a capacity of 16-55 KW, and the working pressure at maximum efficiency is recommended to be 35 mbar. Recommended pressure values should be measured from the closest point to the device when all natural gas devices in the environment are operating (stove, oven, etc.), and the shutoff to be installed should be determined. 's should be no more than 2 meters away from the device.



	Lodos 60	Lodos 70	Lodos 75	Lodos 80	Lodos 85
Capacity	60 kW	69,7 kW	75 kW	80 kW	85 kW
Gas Consumption	NG 3,42-5,70m ³ /h / LPG 2,532-4,22kg/h	NG 3,99-6,65m ³ /h / LPG 2,952-4,92kg/h	NG 4,26-7,13m ³ /h / LPG 3,11-5,27kg/h	NG 4,53-7,55m ³ /h / LPG 3,36-5,60kg/h	NG 4,89-8,43m ³ /h / LPG 3,63-6,35kg/h
Dimensions (mm)	790h / 1057L / 842w	790h / 1057L / 842w	790h / 1057L / 842w	790h / 1057L / 842w	790h / 1057L / 842w
Weight (kg)	Net 103,25kg / Gross 124,04kg	Net 103,25kg / Gross 124,04kg	Net 103,25kg / Gross 124,04kg	Net 103,25kg / Gross 124,04kg	Net 103,25kg / Gross 124,04kg
Heating Area m²	min 300m ² / Avg 350m ² / max 410m ²	min 325m ² / Avg 380m ² / max 460m ²	min 340m ² / Avg 400m ² / max 480m ²	min 355m ² / Avg 420m ² / max 500m ²	min 370m ² / Avg 445m ² / max 525m ²
Heating Area m³	min 822m ³ / Avg 1108m ³ / max 1274m ³	min 868m ³ / Avg 1161m ³ / max 1322m ³	min 880m ³ / Avg 1207m ³ / max 1364m ³	min 905m ³ / Avg 1238m ³ / max 1394m ³	min 935m ³ / Avg 1277m ³ / max 1425m ³
Empty Space Sound	62 d-BA	62 d-BA	62 d-BA	62 d-BA	62 d-BA
Working Environment Sound	50 d-BA	50 d-BA	50 d-BA	50 d-BA	50 d-BA
Flow (m³)	6900m ³	6900m ³	6900m ³	6900m ³	6900m ³
Electrical Connection	230-240VAC 50-60 Hz +/-%15	230-240VAC 50-60 Hz +/-%15	230-240VAC 50-60 Hz +/-%15	230-240VAC 50-60 Hz +/-%15	230-240VAC 50-60 Hz +/-%15
Usage Pressure	21-55mbr NG / 32-55mbr LPG	21-55mbr NG / 32-55mbr LPG	21-55mbr NG / 32-55mbr LPG	21-55mbr NG / 32-55mbr LPG	21-55mbr NG / 32-55mbr LPG
Electricity Consumption	411,3 w/h	411,3 w/h	411,3 w/h	411,3 w/h	411,3 w/h
Gas Connection	G 3/4"	G 3/4"	G 3/4"	G 3/4"	G 3/4"
Box Dimensions	800h / 1060L / 852w	800h / 1060L / 852w	800h / 1060L / 852w	800h / 1060L / 852w	800h / 1060L / 852w

For Daygas Lodos model devices, the natural gas working pressure for devices with a capacity of 60-85 KW is 21 mbar, and the working pressure at maximum efficiency is 35 mbar. The recommended pressure values should be measured from the closest point to the device when all natural gas devices in the environment are operating (stove, oven, etc.) and the regulators to be installed. must be at a distance of no more than 2 meters from the device.

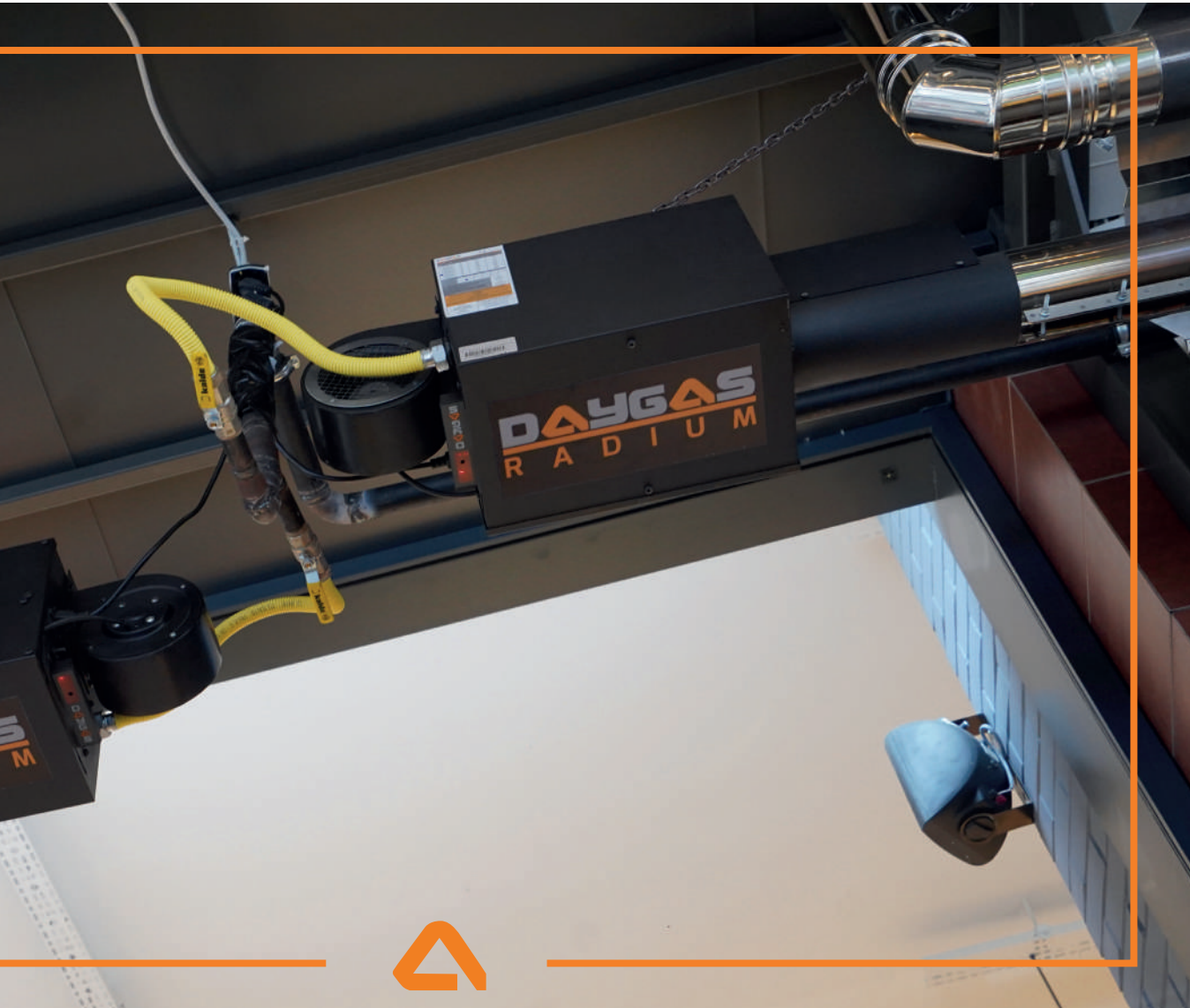

Thanks to radium burners with balanced load distribution and increased flame length and fans with maximized aerodynamics, the products are high-efficiency heating technologies that can continue to operate smoothly for many years without losing performance, as on the first day.



Radium U Pipe Type / Plus

Technical Specifications

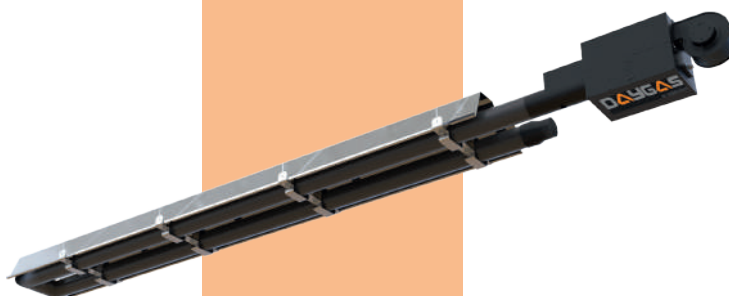

	Radium U 15	Radium U 20	Radium U 30	Radium U 35
Capacity	15 kW	20 kW	30 kW	35 kW
Gas Consumption	NG 0,858-1,43m ³ /h / LPG 0,63-1,05kg/h	NG 1,114-1,90m ³ /h / LPG 0,846-1,41kg/h	NG 1,71-2,85m ³ /h / LPG 1,226-2,11kg/h	NG 1,998-3,33m ³ /h / LPG 2,46 kg/h
Dimensions (mm)	250h / 4200L / 405w	250h / 5700L / 405w	250h / 7200L / 405w	250h / 7200L / 405w
Weight (kg)	Net 65,00kg / Gross 80,00kg	Net 90,00kg / Gross 110,00kg	Net 120,00kg / Gross 150,00kg	Net 120,00kg / Gross 150,00kg
Usage Pressure	21-55mbr NG / 32-55mbr LPG	21-55mbr NG / 32-55mbr LPG	21-55mbr NG / 32-55mbr LPG	21-55mbr NG / 32-55mbr LPG
Empty Space Sound	85 d-BA	85 d-BA	85 d-BA	85 d-BA
Working Environment Sound	70 d-BA	70 d-BA	70 d-BA	70 d-BA
Flow (m³)	2950m ³	2950m ³	2950m ³	2950m ³
Installation Height	250-450cm	250-450cm	260-470cm	280-800cm
Stage	Standard 2 / Plus 5	Standard 2 / Plus 5	Standard 2 / Plus 5	Standard 2 / Plus 5
Electricity Consumption	136,3 w/h	136,3 w/h	136,3 w/h	136,3 w/h
Electrical Connection	230-240VAC 50-60 Hz +/-%15	230-240VAC 50-60 Hz +/-%15	230-240VAC 50-60 Hz +/-%15	230-240VAC 50-60 Hz +/-%15
Gas Connection	G 3/4"	G 3/4"	G 3/4"	G 3/4"

For Daygas Radium model devices, the natural gas working pressure for devices with a capacity of 15-50 KW is 21 mbar, but to get the best efficiency, the recommended natural gas pressure is 35 mbar. The recommended pressure values should be measured from the closest place to the device, and the regulators to be installed should be at a maximum distance of 2 meters from the device.

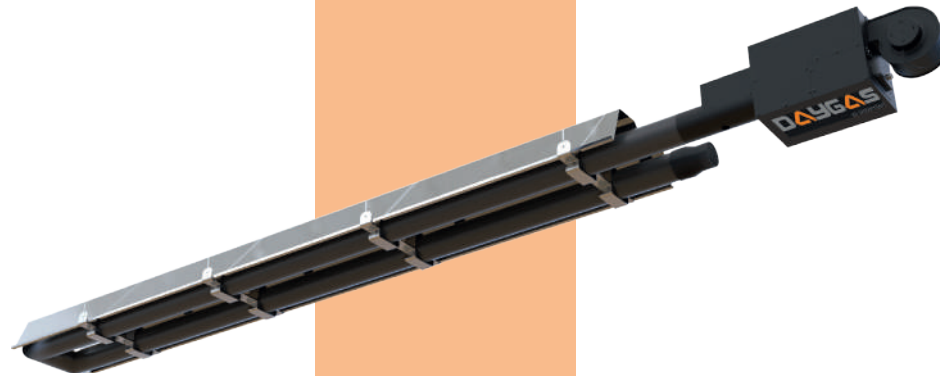

	Radium U 40	Radium U 45	Radium U 50	Radium U 55
Capacity	40 kW	45 kW	50 kW	55 kW
Gas Consumption	NG 2,29-3,80m ³ /h / LPG 1,686-2,81kg/h	NG 2,568-4,28m ³ /h / LPG 1,896-3,16kg/h	NG 2,85-4,75m ³ /h / LPG 2,112-3,52kg/h	NG 3,138-5,23m ³ /h / LPG 2,322-3,87kg/h
Dimensions (mm)	250h / 7200L / 405w	250h / 8700L / 405w	250h / 8700L / 405w	250h / 10200L / 405w
Weight (kg)	Net 120,00kg / Gross 150,00kg	Net 155,00kg / Gross 185,00kg	Net 155,00kg / Gross 185,00kg	Net 175,00kg / Gross 220,00kg
Usage Pressure	21-55mbr NG / 32-55mbr LPG	21-55mbr NG / 32-55mbr LPG	21-55mbr NG / 32-55mbr LPG	21-55mbr NG / 32-55mbr LPG
Empty Space Sound	85 d-BA	85 d-BA	85 d-BA	85 d-BA
Working Environment Sound	70 d-BA	70 d-BA	70 d-BA	70 d-BA
Flow (m³)	2950m ³	2950m ³	2950m ³	2950m ³
Installation Height	300-900cm	320-1000cm	350-1200cm	400-1300cm
Stage	Standard 2 / Plus 5	Standard 2 / Plus 5	Standard 2 / Plus 5	Standard 2 / Plus 5
Electricity Consumption	136,3 w/h	136,3 w/h	136,3 w/h	136,3 w/h
Electrical Connection	230-240VAC 50-60 Hz +/-%15	230-240VAC 50-60 Hz +/-%15	230-240VAC 50-60 Hz +/-%15	230-240VAC 50-60 Hz +/-%15
Gas Connection	G 3/4"	G 3/4"	G 3/4"	G 3/4"

For Daygas Radium model devices, the natural gas working pressure for devices with a capacity of 15-50 KW is 21 mbar, but to get the best efficiency, the recommended natural gas pressure is 35 mbar. The recommended pressure values should be measured from the closest place to the device, and the regulators to be installed should be at a maximum distance of 2 meters from the device.

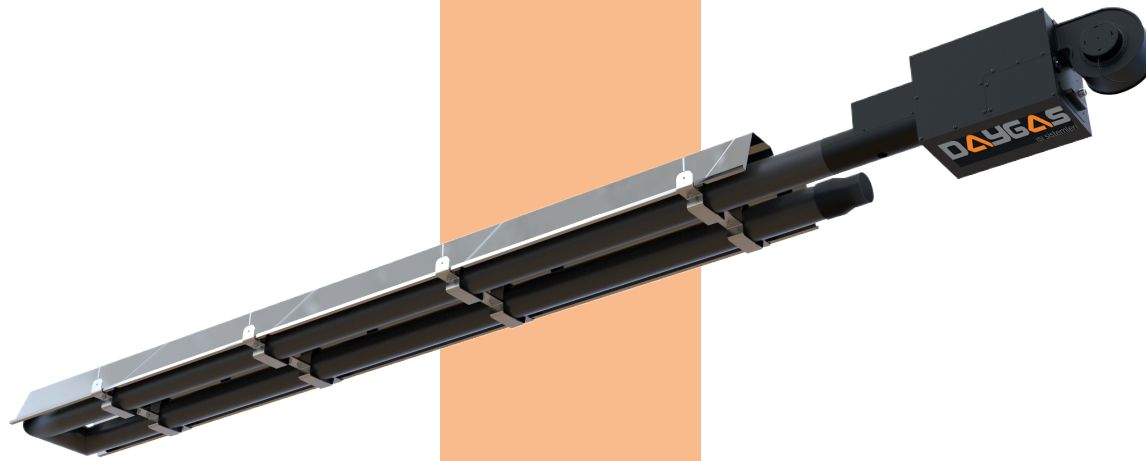

	Radium U 60	Radium U 71
Capacity	60 kW	69,7 kW
Gas Consumption	NG 3,42-5,70m ³ /h / LPG 2,532-4,22kg/h	NG 4,05-6,75m ³ /h / LPG 2,994-4,99kg/h
Dimensions (mm)	250h / 10200L / 405w	250h / 13200L / 405w
Weight (kg)	Net 175,00kg / Gross 220,00kg	Net 200,00kg / Gross 240,00kg
Usage Pressure	21-55mbr NG / 32-55mbr LPG	21-55mbr NG / 32-55mbr LPG
Empty Space Sound	85 d-BA	85 d-BA
Working Environment Sound	70 d-BA	70 d-BA
Flow (m ³)	2950m ³	2950m ³
Installation Height	425-1350cm	450-1400cm
Stage	Standard 2 / Plus 5	Standard 2 / Plus 5
Electricity Consumption	136,3 w/h	136,3 w/h
Electrical Connection	230-240VAC 50-60 Hz +/-%15	230-240VAC 50-60 Hz +/-%15
Gas Connection	G 3/4"	G 3/4"

For Daygas Radium model devices with a capacity of 55-69.7 KW, the natural gas working pressure is 21 mbar, but to get the best efficiency, the recommended natural gas pressure is 50 mbar. Recommended pressure values should be measured from the closest place to the device, and the regulators to be installed should be at a maximum distance of 2 meters from the device.

Radium I Pipe Type / Plus

Technical Specifications

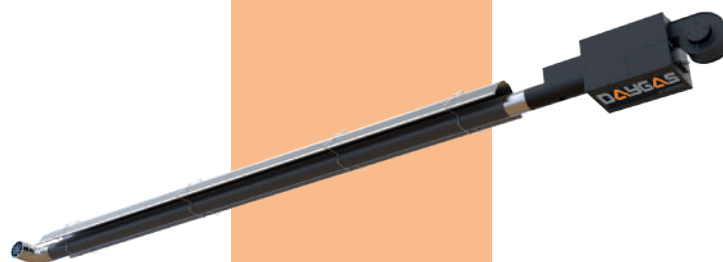

	Radium I 15	Radium I 20	Radium I 30
Capacity	15 kW	20 kW	30 kW
Gas Consumption	NG 0,858-1,43m ³ /h / LPG 0,63-1,05kg/h	NG 1,114-1,90m ³ /h / LPG 0,846-1,41kg/h	NG 1,71-2,85m ³ /h / LPG 1,226-2,11 kg/h
Dimensions (mm)	250h / 6900L / 405w	250h / 6900L / 405w	250h / 9900L / 260w
Weight (kg)	Net 60,00kg / Gross 80,00kg	Net 60,00kg / Gross 80,00kg	Net 85,00kg / Gross 105,00kg
Usage Pressure	21-55mbr NG / 32-55mbr LPG	21-55mbr NG / 32-55mbr LPG	21-55mbr NG / 32-55mbr LPG
Empty Space Sound	85 d-BA	85 d-BA	85 d-BA
Working Environment Sound	70 d-BA	70 d-BA	70 d-BA
Flow (m³)	2950m ³	2950m ³	2950m ³
Installation Height	250-450 _{cm}	250-450 _{cm}	260-470 _{cm}
Stage	Standard 2 / Plus 5	Standard 2 / Plus 5	Standard 2 / Plus 5
Electricity Consumption	136,3 w/h	136,3 w/h	136,3 w/h
Electrical Connection	230-240VAC 50-60 Hz +/-%15	230-240VAC 50-60 Hz +/-%15	230-240VAC 50-60 Hz +/-%15
Gas Connection	G 3/4"	G 3/4"	G 3/4"

For Daygas Radium model devices with a capacity of 55-69.7 KW, the natural gas working pressure is 21 mbar, but to get the best efficiency, the recommended natural gas pressure is 50 mbar. Recommended pressure values should be measured from the closest place to the device, and the regulators to be installed should be at a maximum distance of 2 meters from the device.



	Radium I 35	Radium I 40	Radium I 45
Capacity	35 kW	40 kW	45 kW
Gas Consumption	NG 1,998-3,33m ³ /h / LPG 2,46 kg/h	NG 2,28-3,80m ³ /h / LPG 1,686-2,81kg/h	NG 2,568-4,28m ³ /h / LPG 1,896-3,16kg/h
Dimensions (mm)	250h / 9900L / 260w	250h / 12900L / 260w	250h / 12900L / 260w
Weight (kg)	Net 85,00kg / Gross 105,00kg	Net 110,00kg / Gross 150,00kg	Net 110,00kg / Gross 150,00kg
Usage Pressure	21-55mbr NG / 32-55mbr LPG	21-55mbr NG / 32-55mbr LPG	21-55mbr NG / 32-55mbr LPG
Empty Space Sound	85 d-BA	85 d-BA	85 d-BA
Working Environment Sound	70 d-BA	70 d-BA	70 d-BA
Flow (m³)	2950m ³	2950m ³	2950m ³
Installation Height	280-800cm	300-900cm	320-1000cm
Stage	Standard 2 / Plus 5	Standard 2 / Plus 5	Standard 2 / Plus 5
Electricity Consumption	136,3 w/h	136,3 w/h	136,3 w/h
Electrical Connection	230-240VAC 50-60 Hz +/-0%15	230-240VAC 50-60 Hz +/-0%15	230-240VAC 50-60 Hz +/-0%15
Gas Connection	G 3/4"	G 3/4"	G 3/4"

For Daygas Radium model devices, the natural gas working pressure for devices with a capacity of 15-50 KW is 21 mbar, but to get the best efficiency, the recommended natural gas pressure is 35 mbar. The recommended pressure values should be measured from the closest place to the device, and the regulators to be installed should be at a maximum distance of 2 meters from the device.



	Radium I 50	Radium I 55
Capacity	50 kW	55 kW
Gas Consumption	NG 2,85-4,75m ³ /h / LPG 2,112-3,52kg/h	NG 3,138-5,23m ³ /h / LPG 2,322-3,87kg/h
Dimensions (mm)	250h / 12900L / 260w	250h / 15900L / 260w
Weight (kg)	Net 110,00kg / Gross 150,00kg	Net 135,00kg / Gross 185,00kg
Usage Pressure	21-55mbr NG / 32-55mbr LPG	21-55mbr NG / 32-55mbr LPG
Empty Space Sound	85 d-BA	85 d-BA
Working Environment Sound	70 d-BA	70 d-BA
Flow (m³)	2950m ³	2950m ³
Installation Height	350-1200cm	400-1300cm
Stage	Standard 2 / Plus 5	Standard 2 / Plus 5
Electricity Consumption	136,3 w/h	136,3 w/h
Electrical Connection	230-240VAC 50-60 Hz +/- %15	230-240VAC 50-60 Hz +/- %15
Gas Connection	G 3/4"	G 3/4"

For Daygas Radium model devices with a capacity of 55-69.7 KW, the natural gas working pressure is 21 mbar, but to get the best efficiency, the recommended natural gas pressure is 50 mbar. Recommended pressure values should be measured from the closest place to the device, and the regulators to be installed should be at a maximum distance of 2 meters from the device.



	Radium I 60	Radium I 71
Capacity	60 kW	69,7 kW
Gas Consumption	NG 3,42-5,70m ³ /h / LPG 2,532-4,22kg/h	NG 4,05-6,75m ³ /h / LPG 2,994-4,99kg/h
Dimensions (mm)	250h / 15900L / 405w	250h / 18900L / 405w
Weight (kg)	Net 135,00kg / Gross 185,00kg	Net 160,00kg / Gross 230,00kg
Usage Pressure	21-55mbr NG / 32-55mbr LPG	21-55mbr NG / 32-55mbr LPG
Empty Space Sound	85 d-BA	85 d-BA
Working Environment Sound	70 d-BA	70 d-BA
Flow (m³)	2950m ³	2950m ³
Installation Height	425-1350cm	450-1400cm
Stage	Standard 2 / Plus 5	Standard 2 / Plus 5
Electricity Consumption	136,3 w/h	136,3 w/h
Electrical Connection	230-240VAC 50-60 Hz +/- %15	230-240VAC 50-60 Hz +/- %15

For Daygas Radium model devices with a capacity of 55-69.7 KW, the natural gas working pressure is 21 mbar, but to get the best efficiency, the recommended natural gas pressure is 50 mbar. Recommended pressure values should be measured from the closest place to the device, and the regulators to be installed should be at a maximum distance of 2 meters from the device.

» Sound db was measured in a laboratory environment. Sound db +/- may vary depending on the installation environment. Sound db measurements are made at a minimum distance of 5m from the device. Measurement distances may vary depending on capacity and hanging height.

S O L I S

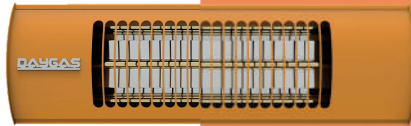
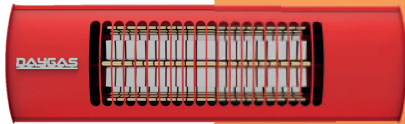
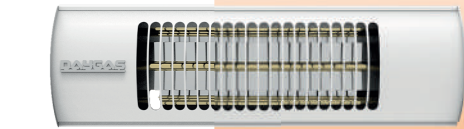

With Solis
Effective Heating Solutions for Open Areas

- » Protection Rating IP67
- » Parabolic Reflectors
- » Different Color Options
- » Using with or without remote control possibility.

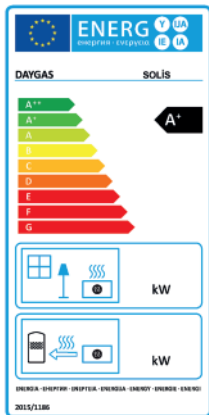
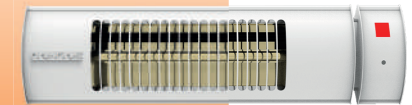

Solis

Technical Specifications



Solis 4000
With Remote

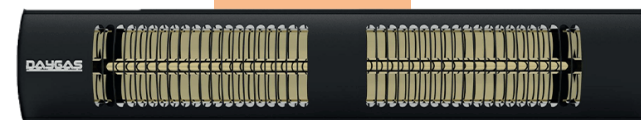

Solis 4000
Without Remote



Solis 2000
With Remote

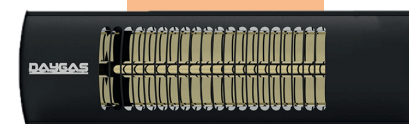

Solis 2000
Without Remote

	Solis 2000 with Remote	Solis 4000 with Remote	Solis 2000 without Remote	Solis 4000 without Remote	Solis 8000 Industrial	Solis 12000 Industrial
Capacity	2000 W	4000 W	2000 W	4000 W	8000 W	12000 W
Electricity Consumption	2 kW/h	4 kW/h	2 kW/h	4 kW/h	8 kW/h	12 kW/h
Dimensions (mm)	140h / 545L / 85w mm	140h / 1025L / 85w mm	140h / 470L / 85w mm	140h / 940L / 85w mm	450h / 750L / 100w mm	450h / 750L / 100w mm
Weight (kg)	1,60kg	2,65kg	1,10kg	2,30kg	8,80kg	9,30kg
Electrical Connection	190-230 VAC / 50-60 Hz 230-240VAC 50-60Hz +/- %15	190-230 VAC / 50-60 Hz 230-240VAC 50-60Hz +/- %15	190-230 VAC / 50-60 Hz 230-240VAC 50-60Hz +/- %15	190-230 VAC / 50-60 Hz 230-240VAC 50-60Hz +/- %15	190-230 VAC / 50-60 Hz 230-240VAC 50-60Hz +/- %15	190-230 VAC / 50-60 Hz 230-240VAC 50-60Hz +/- %15
Heating Area	min 7m ² / Avg 10m ² / max 15m ²	min 15m ² / Avg 21m ² / max 28m ²	min 7m ² / Avg 10m ² / max 15m ²	min 15m ² / Avg 21m ² / max 28m ²	min 45m ² / Avg 50m ² / max 65m ²	min 65m ² / Avg 78m ² / max 90 m ²
Installation Height	150-250cm	150-250cm	150-250cm	150-250cm	150-250cm	150-250cm
IP Standards	--	--	IP67	IP67	IP67	IP67
Halogen Bulb Life	Avg. 7000 Hour	Avg. 7000 Hour	Avg. 7000 Hour	Avg. 7000 Hour	Ort. 7000 Hour	Avg. 7000 Hour
Power Supply	Monofaze	Monofaze	Monofaze	Monofaze	Trifaze	Trifaze

A C C E S S O R I E S



**25 cm
Chimney**



**50 cm
Chimney**



**100 cm
Chimney**



15° Elbow



30° Elbow



45° Elbow



90° Elbow



Protected Elbow



**Wall Fixing
Clamps Eko**



**Wall Fixing
Clamps Eko 11**



**Wall Fixing
Clamps Eko 21**



**Glass AndWall
Cover**



LPG Stand Up Kit



**Lodos Wall
Mounting Kit**



**Rain & Wind
Protected Hat**



Master Flash

Device Controls

There are different scenarios and control elements related to controlling devices.

1. Integration into the automation system. (Control over Scada)
2. Entagration over the control board.
3. Manual control with Pako switching.
4. Automatic control with thermostat switching.
5. Remote controlled.

Offering 5 different alternatives, the variety of control scenarios allows the products to be managed in a correct and desired way. The most appropriate control scenario is selected by evaluating the on-site usage situation and space conditions of the control of the devices in our product range. Therefore, control with the right solution scenario both saves fuel and facilitates long-lasting trouble-free service.

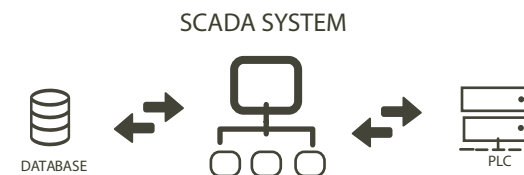

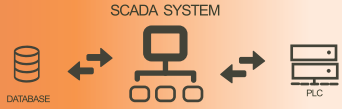

Integration to Automation System (Control via Scada)

Our devices can be integrated directly into building automation systems (BMS) with Modbus communication protocol via RS485 port (internal), or if there is no existing BMS system, the control of the devices can be used fully automatically from a single center via HMI touch panel or a PC.

In BMS System

- » Operation of heaters with zonal or individual stage and modulation control,
- » Cihazların belirlenen gün ve saatlerde çalıştırılma emri,
- » Seeing and keeping in memory what device is wrong with fault codes from devices in the system,
- » Functional controls such as instant, daily, weekly or monthly observation of fuel consumption are the advantages of the system integrated into automation.

Analog Room Thermostat

The Daygas analog room thermostat automatically turns off the device when the heat value you set is approached, and then when the ambient temperature drops below the desired heat value, the device automatically activates at the maximum level and starts working again. In this way, it saves fuel.



Digital Heat Sensor

- » Freezing protection mode.
- » Setting heat over the device.
- » Modulated control possibility.
- » Used with digital heat sensor control board.

When your devices approach the heat value you programmed with the Daygas heat sensor, saves fuel by reducing the modulation value of the device according to weather conditions. When the medium reaches the desired heat value, the device automatically shuts off and then falls below the desired value, the device is automatically activated at the temperature level most suitable for the environment starts working again.



Control Panel

- » Encrypted protection.
- » Heat protection mode.
- » Freezing protection feature.
- » 128 x 64 graphic LCD screen.
- » Computer communication port.
- » 24/7 programmability.
- » Automatic and manual control possibility.
- » Ability to connect external heat sensor.
- » Possibility to control 8 independent zones and a total of 32 devices.

It simplifies your work thanks to many commands, from the command to turn on and off devices on the desired working days and at the time intervals you want, to ensure that the environment remains warm, in the range of heat values determined for freezing protection when the business is closed.

Remote Control

Daygas remote controls are controllers with 3 buttons on it and with easy functions, offering simple use. Thanks to the Daygas remote control, all fonions such as on-off, heat adjustment upgrade-fall and reset can be easily controlled. All Daygas products can be controlled remotely with a single control.



Manual Control with Pako Switching

With the Pako switched control, manual control with tier adjustment can be provided over the paco. Devices can be operated at the desired level via the paco switch for more local solutions where there is no control board or is not required.

- » Heaters can be controlled independently.
- » Since the device energy is not cut off at stand - by (0) via Pako, it goes to sleep after the device shut-off procedures to be shut down, so that the devices are provided with long-lasting service.
- » The device's control is not used when the pako is used conditionally.

E OF LOCAL







With Daygas Effective Heating in All Areas Hard to Heating

- » Cafes
- » Greenhouses
- » Workshops
- » Factories
- » Stadiums
- » Restaurants
- » Open Areas
- » Sports Halls
- » Places Of Worship
- » Industrial Facilities

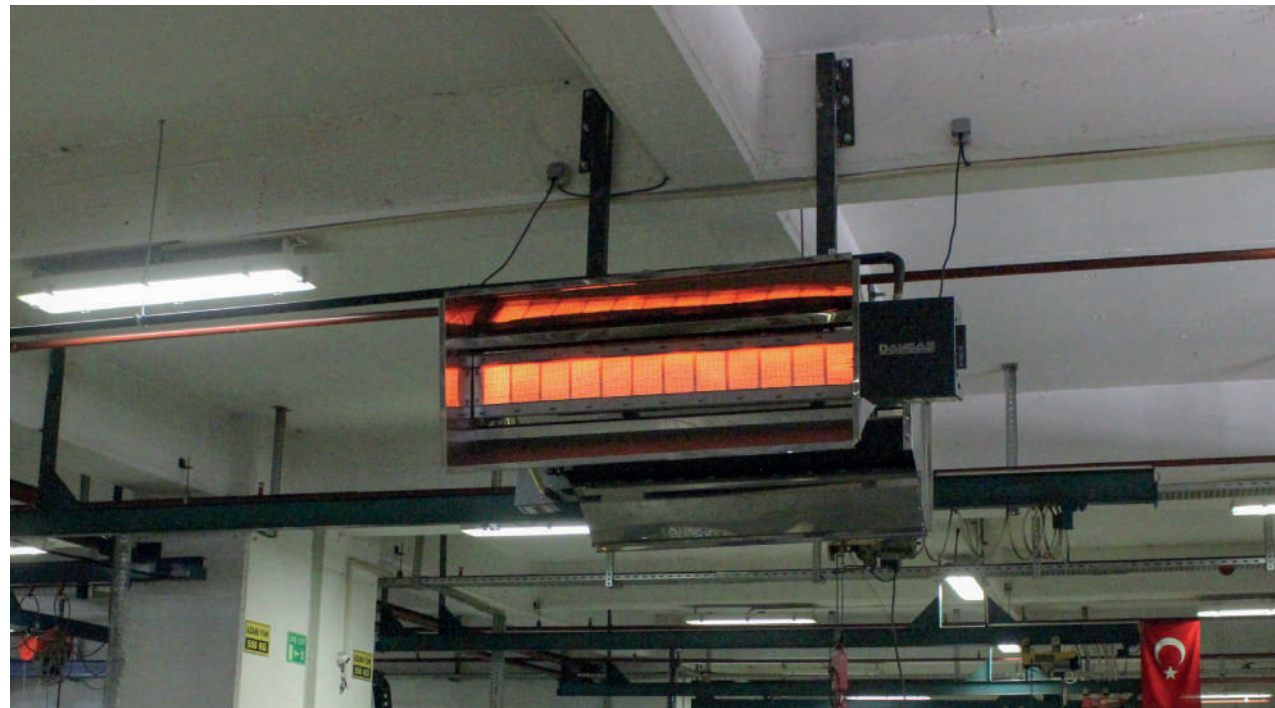



Factory

+90 850 532 91 53

+90 212 423 30 44

info@daygas.eu

www.daygas.eu

Firuzköy Bulvarı No: 206 / 1, 34325 Avcılar / İstanbul - Türkiye

