

“Blooming”

New Glass Containers Series design

PATENT
PENDING



IKOO GLASS

Designed by IKOO Create Design Center



**PATENT
PENDING**

IKOO GLASS

Blooming Series

Project Overview:

Develop a new series of glass food storage containers.

Variety of Sizes:

Offer three different diameters, each with three depths,

Nesting Feature:

Enable the glass containers to nest within each other.

Stacking Capability:

Design the containers with lids to be stackable with one another.



IKOO GLASS



Part 1. The Glass



**PATENT
PENDING**

IKOO GLASS

Part 1. The glass

- Design Research

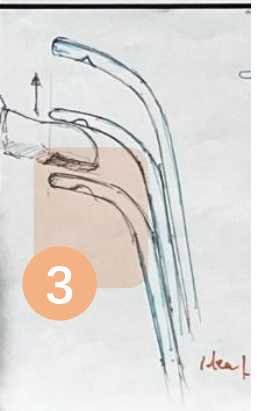
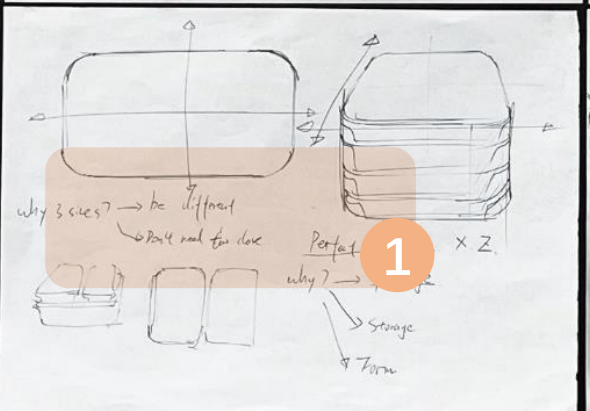
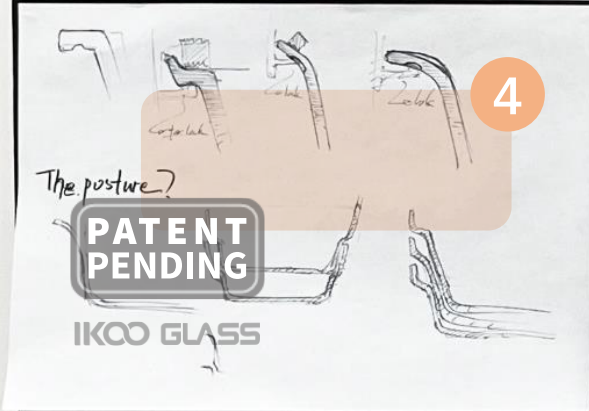
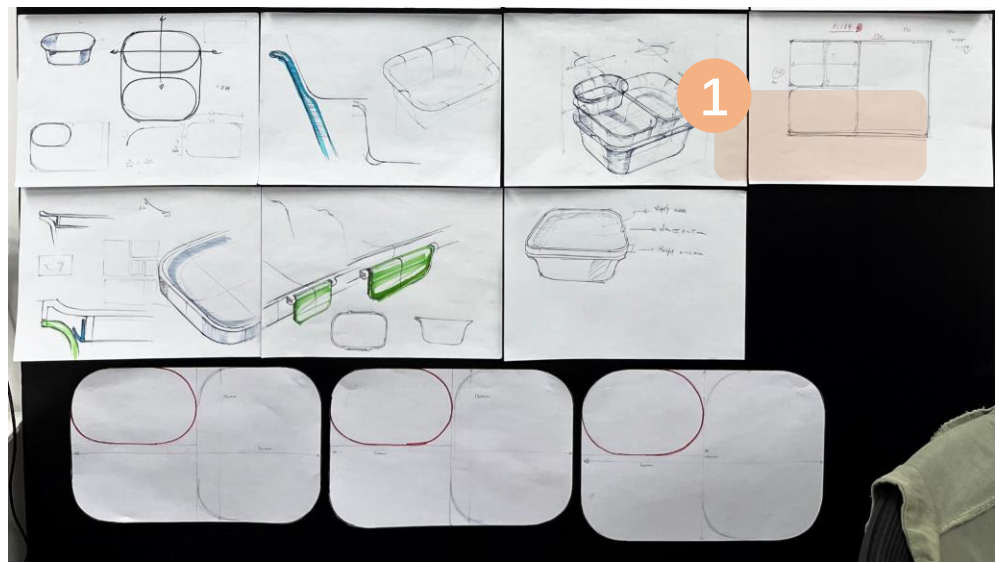
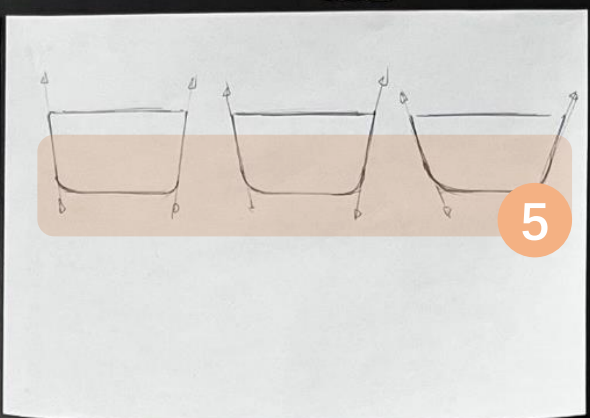
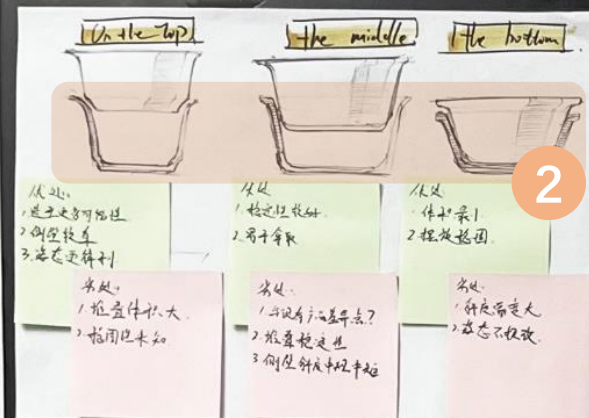

Initially, we researched...

- 1 The Size & Proportion
- 2 Way of stacking
- 3 The user
- 4 Mouth of container
- 5 The emotion of glass

Part 1. The glass

- The size & proportion

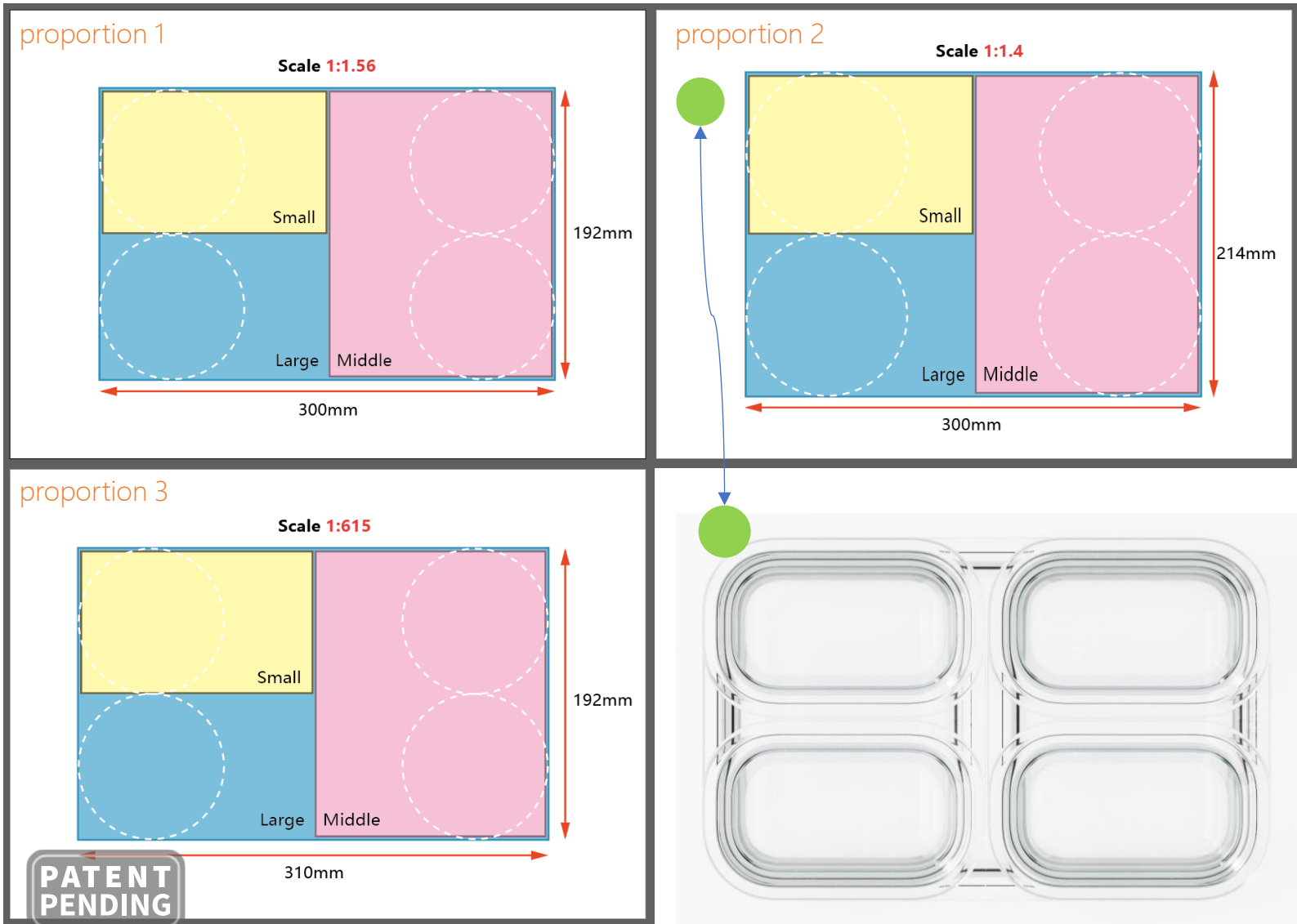

PATENT PENDING

IKCO GLASS

Reasons for choosing proportion 2

- 1. Proportions closer to the golden ratio overall.
- 2. Proportions of each model are as close as possible.
- 3. Sizes compatible with more microwaves or ovens.

Part 1. The glass
- The User & Stacking way

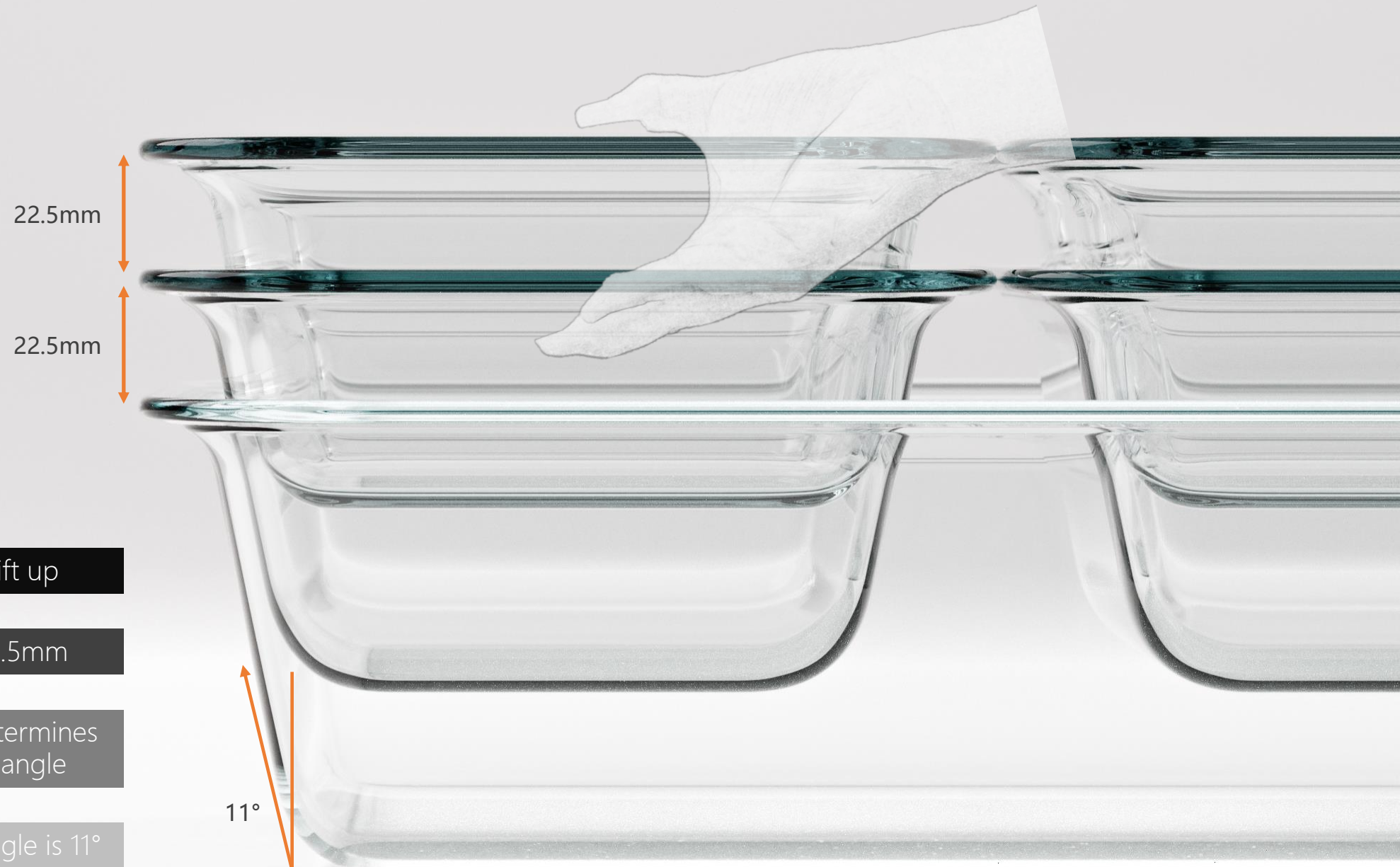

Easy to lift up

Gap is 22.5mm

The gap determines the draft angle

The draft angle is 11°

**PATENT
PENDING**

IKCO GLASS

Part 1. The glass

- The design of the mouth

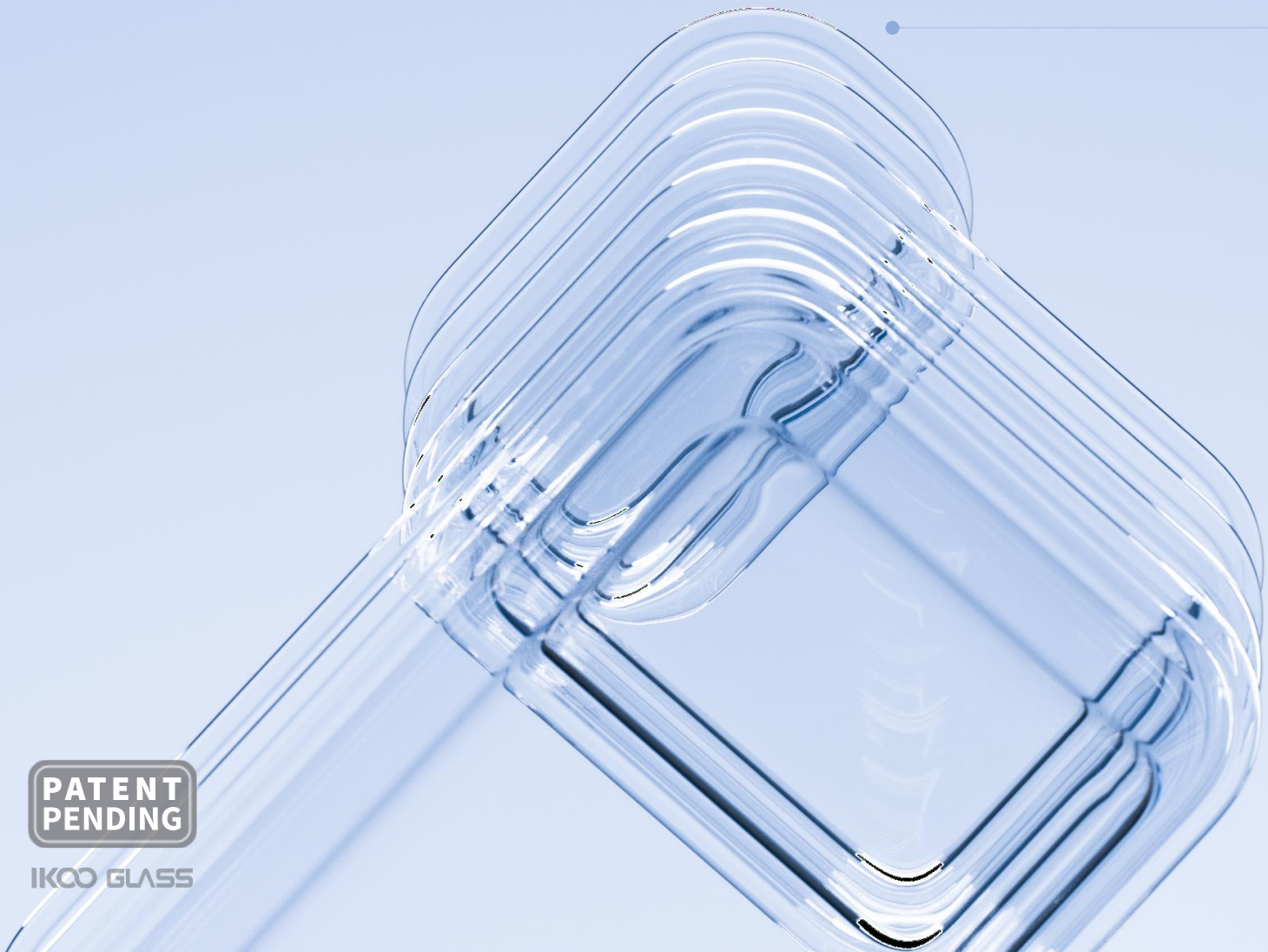

The rounded corners of each model are exactly the same.

They feature a very aesthetically pleasing curvature

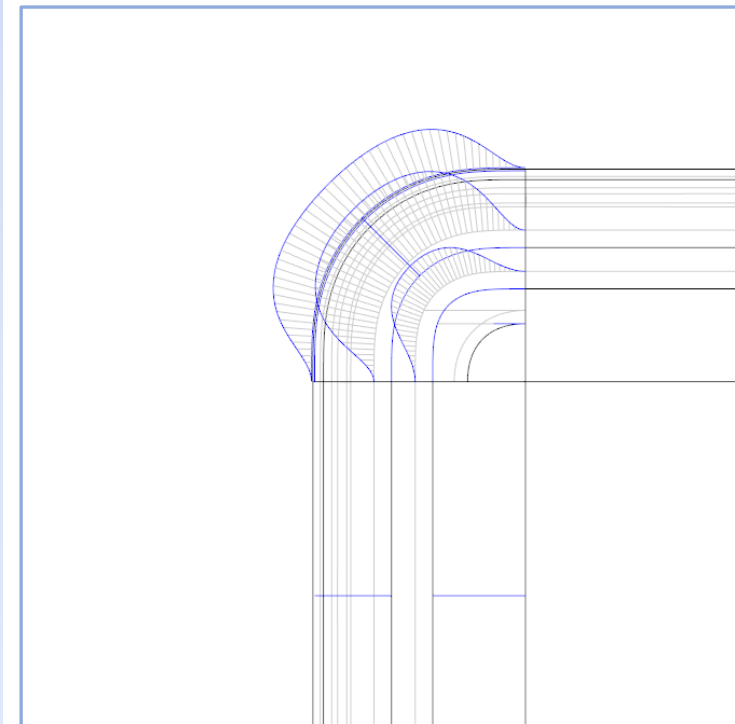

**PATENT
PENDING**

IKOO GLASS

Part 1. The glass
- The design of the mouth



**PATENT
PENDING**

IKOO GLASS

Consistent rounded corners save **packaging space** and enhance stability.

Part 1. The glass
- The design of the mouth



New Longer edges for easier grip.

Old

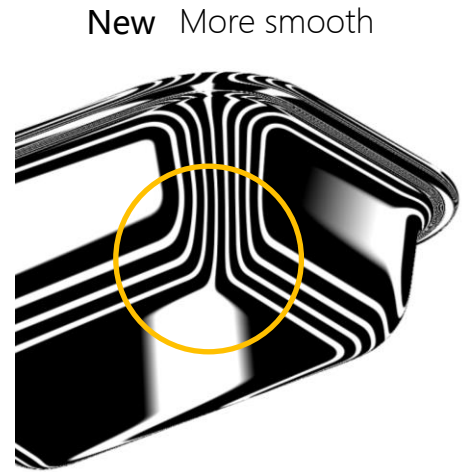

Old Not fluid

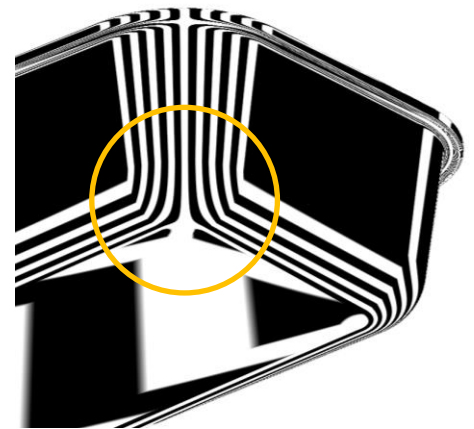

**PATENT
PENDING**

IKCO GLASS

By removing unnecessary edges,
the glass appears visually very lightweight, refined, and complete.

Part 1. The glass

- About volume



**PATENT
PENDING**

IKOO GLASS

Large

Temporarily
not started



L-High
303*216*75 mm
3040ml

L-Mid
303*216*60 mm
2450ml



Temporarily
not started



L-Low
303*216*45 mm
1820ml

Detail



**PATENT
PENDING**

IKOO GLASS

Middle



M-High

216*150*75 mm

1150ml

M-Mid

216*150*60 mm

940ml



M-Low

216*150*45 mm

700ml

Detail



**PATENT
PENDING**

IKOO GLASS

Part 1. The glass

- The Photo



**PATENT
PENDING**

IKOO GLASS



Stackable

Each glass can be stackable with each others.

**PATENT
PENDING**

IKOO GLASS

Part 1. The glass

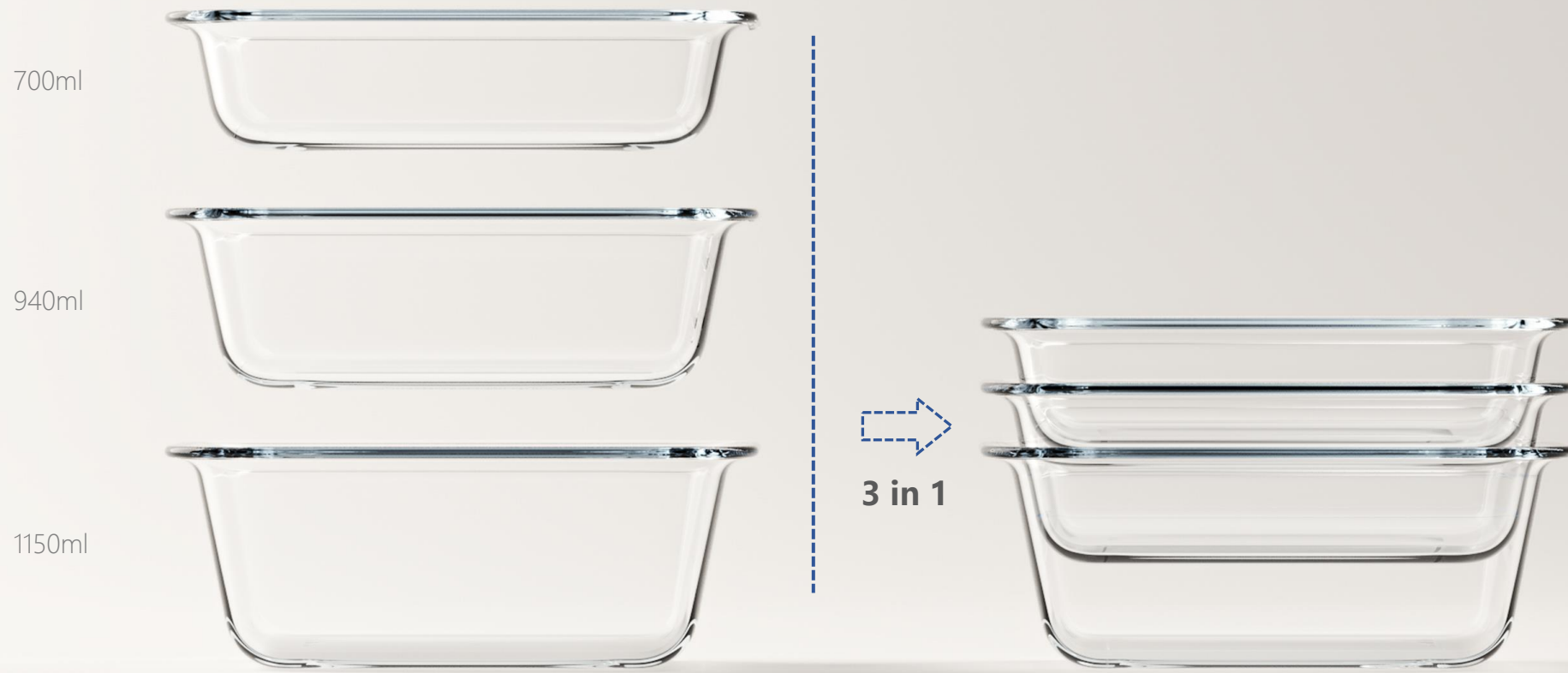

**PATENT
PENDING**

IKOO GLASS

Part 2. The Lid



**PATENT
PENDING**

IKOO GLASS



**PATENT
PENDING**

IKOO GLASS

Stackable

Lock Lids can be stacked while covered.



**PATENT
PENDING**

IKOO GLASS

Part 2. The lid

- About Size

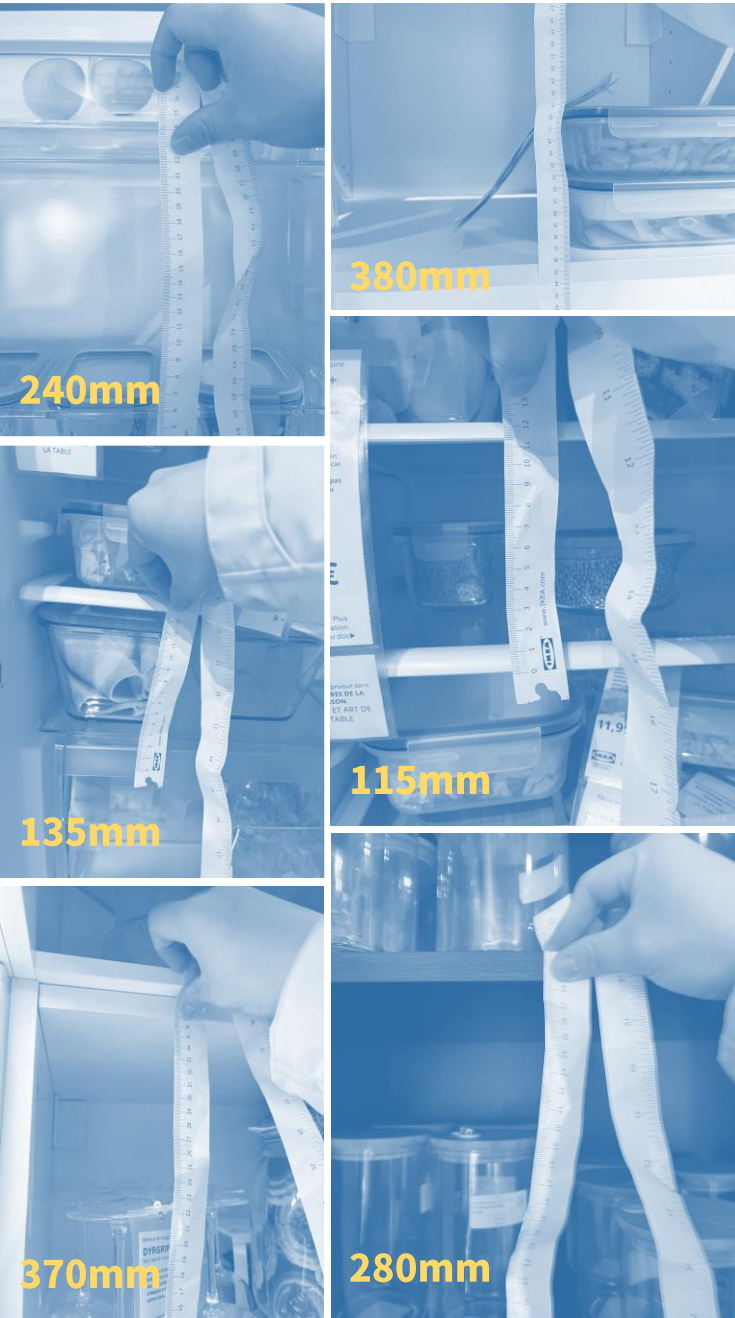

Based on the research on the size of cabinets and refrigerators, we established the size of the container to suit various scenarios.



**PATENT
PENDING**

IKOO GLASS

The stacked height matches that of a standard beer can, making it very convenient for storage.



**PATENT
PENDING**

IKOO GLASS



Part 2. The lid

- Concept 1



**PATENT
PENDING**

IKOO GLASS



Core Set Design Principles

Consumer Convenience: Ensure combinations are practical for typical kitchen, cooking, and storage scenarios. Most users prioritize utility, simplicity, and a good value proposition.



Scalability: Create a base starter kit with essential items and allow for easy expansion with add-ons.

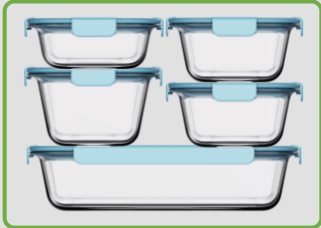

Proposed Bundles

Sales Kits	Element	Goal	Target audience	Prices
Starter Kit	 <p>4pcs M-Low*1 M-Mid*1</p>	Provide an entry-level experience or supplement purchase	Aimed at young people, students and those who need to replenish their family's freshness boxes	
Basic Pack	 <p>6pcs M-Low*1 M-Mid*1 M-High*1</p>	Provide a basic dining and storage experience	For people who are single, living alone or temporarily renting an apartment	
Family Dining Set	 <p>10PCS M-Low*1 M-Mid*2 M-High*1 L-Mid*1</p>	Meets the storage and take-home meal needs of a family of 3-4 people	Home user focused	

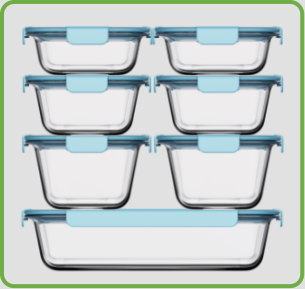
Proposed Bundles

Sales Kits	Element	Goal	Target audience	Prices
Family Cooking Set	 <p>14PCS M-Low*2 M-Mid*2 M-High*2 L-Mid*1</p>	Comprehensive kitchen storage solutions	The choice for large families as well as cooking enthusiasts	
High-end home cooking set	 <p>18PCS M-Low*2 M-Mid*4 M-High*2 L-Mid*1</p>	The Smart Choice for Extra Large Families	For Amazon customers and users	
Glass set	 <p>3pcs M-Low*1 M-Mid*1 M-High*1</p>	Provision of glass replenishment; sale of individual glass in the form of sales of tableware	Those who need to replenish, or use as tableware	

Proposed Bundles



4 Pcs M-Low*1
M-Mid *1



6 Pcs M-Low *1 M-High*1
M-Mid *1



10 Pcs M-Low*1 M-High*1
M-Mid *2 L-Mid *1



14 Pcs M-Low*2 M-High*2
M-Mid *2 L-Mid *1



18 Pcs M-Low*1 M-High*1
M-Mid *1 L-Mid *1

Its ultra-thin and crystal clear appearance gives it an advantage over existing fresh food containers on the market.

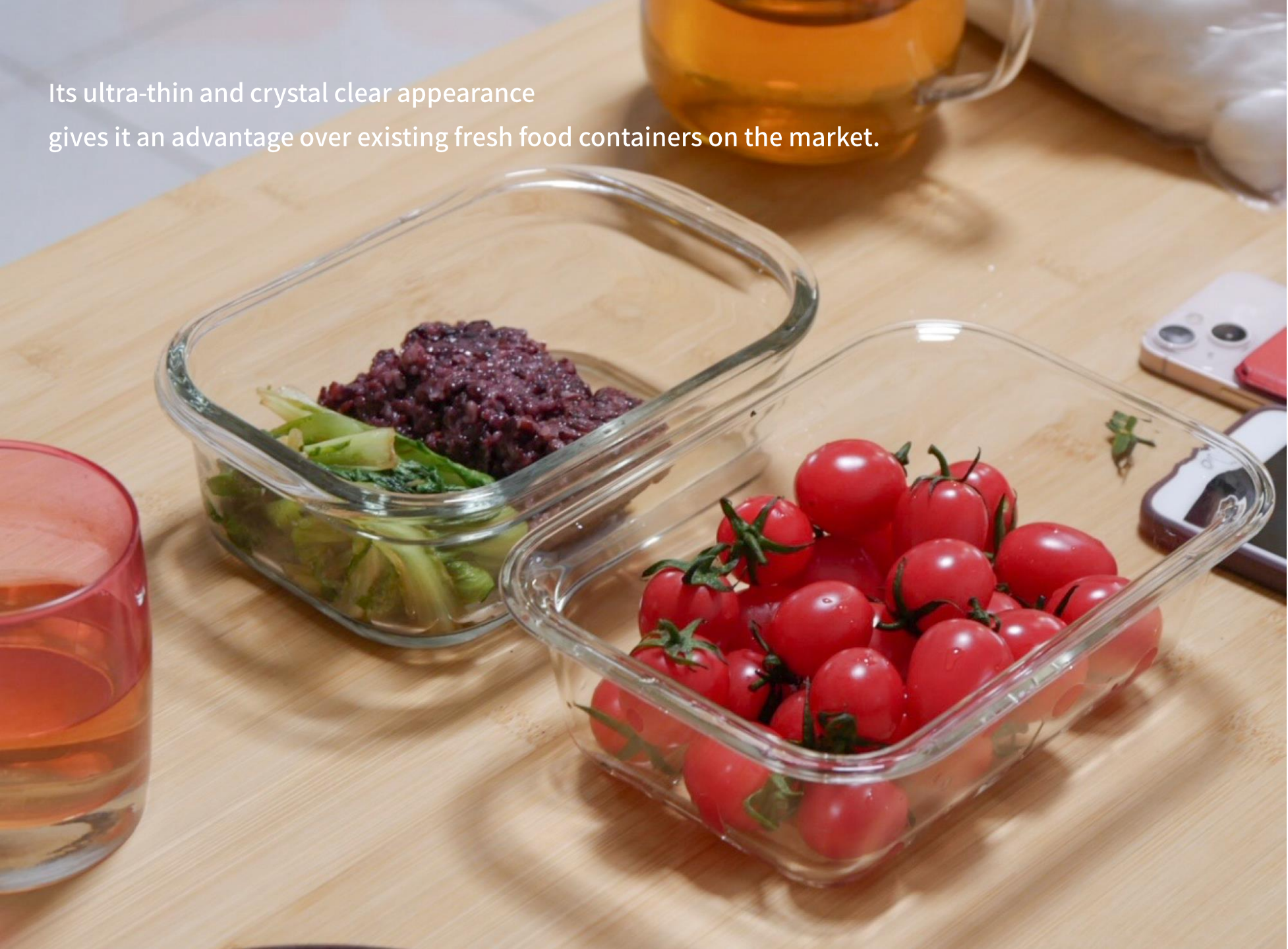

Summary

Glass: Excellent user experienc

1. Space Saving

Smaller space required for nesting due to larger draft angle.

2. Easy to clean

Very easy to clean as there are no dead corners and they are all softly curved

3. Elegant and beautiful

Due to its fine and delicate design, it is lighter and smoother than any glass on the market.

4. Ultra-light weight

Reduces weight by 10% compared to the same capacity container (**1050ml 565g M-Mid 515g**)

5. Good generality

Same mouth size, one lid for all three capacities.

Lid: Market-leading minimalist design

1. PP LID

For a similar price, the design is far different from other PP locking lids on the market.

2. Modular

Free matching of any size with each other to maximise the use of user storage space

Thank you

IKOO GLASS

Designed by IKOO CDC