



C A T A L O G

2025 FW
GAS APPLIANCES
Professional Manufacturer

Discover our latest products.

01



01 Factory [Asan, Korea]

02



02 Factory [Jin Cheon, Korea]

03



03 Head Office [Seoul, Korea]

04



04 Factory [Dalian, China]

05



05 Factory [Hai Phong, Vietnam]

06



06 MAXSUN VINA COMPANY LIMITED [Stove factory in Hai Phong, Vietnam]



MAXSUN (Dalian) Co., Ltd.

Leading Manufacturer of Portable Gas Appliances & Hardware Fittings

WHO WE ARE

Established in **2003** in **Dalian, China**, Maxsun designs and manufactures **Portable Gas Stoves, Gas Torches, Grills/Griddles**, and precision hardware components under a **one-stop, in-house system** (R&D → Tooling → Stamping → Coating → Assembly → Testing → Packaging).

Note: Our regulators feature ultra-precision machined components for stable flow control and enhanced safety.

KEY FACTS

- **Integrated Facilities:** Assembly lines, mold/tooling workshops, printing & coating lines, **porcelain enamel coating**, regulator assembly, stamping, and precision test labs.
 - **Global Compliance:** **CSA · CE · UKCA · AGA · UL · KGS · SASO · ISO · BSCI** (varies by model)
 - **Markets Served:** **North America · Europe · Australia · Asia · Africa (in over 80 countries)**
-

PRODUCT FAMILIES

- **Single / Double Burner Stoves**
Compact & durable solutions for camping and home emergency use.
 - **Ceramic / Infrared Series**
High efficiency with low-noise heating performance.
 - **Commercial & Foldable Series**
Robust, space-saving designs for professional and outdoor applications.
 - **Accessories & Regulators**
Gas torches, grills/griddles, regulators, carry cases and more.
Our regulators incorporate ultra-precision machined components delivering stable flow control and enhanced safety.
-

Maxsun = Safety & Reliability

From design to shipment, safety-first processes deliver reliable, certified performance worldwide.

WHY MAXSUN

- **Quality First:** Strict adherence to international standards and audited QA systems; incoming QC for precision parts
- **Speed & Consistency:** In-house tooling, coating, and assembly ensure short lead times and uniform quality.
- **Partner-Centric:** Region-specific certifications and turnkey packaging options for global brands.

- Stamping line



- Powder coating line



- Porcelain enamel coating line



- Printing line

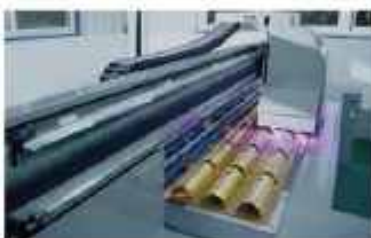

- Valve/Regulaor machining and assembling line



- Main assembling line



CONTENTS

Indoor stove FSD	P01-P02
Flame supervision device stove	P03-P04
Camping stove	P05-P06
Compact Camping stove	P07
Dual-fuel stove	P08
Deluxe aluminium stove	P09-P12
Ultra Mini stove	P13-P14
Latte stove	P15-P16
Double Flame Mini stove	P17
Commercial gas cooking stove	P18
Single burner stove	P19
Safety Plus Strong stove	P20-P21
BSF	P22
Single burner stove	P23-P26
Double Espresso Bi Flame Pro	P27
Wide grill stove & Wide stove	P28-P29
Infrared stove	P30-P31
Proper stove	P32
Double flame stove	P33
Five atomic stove	P34
Spendour stove	P35
BBQ stove & Grill pan stove	P36-P37
Camping Kit	P38-P40
Foldable stove	P41-P42
Camping gas cartridge	P43
Butane gas cartridge	P44-P45
Camping lantern	P46-P47
Gas torch	P48-P49
Accessories	P50-P52

FLAME SUPERVISION DEVICE

INDOOR STOVE FSD

NEW TANK PRO STOVE





What is Flame Supervision Device?

When the burner flames go out for any reason, Flame Supervision Device (FSD) shuts off the fuel supply to a gas burner to prevent accumulations of gas which lead to an explosion or a fire.



- 1. Economic inner flame burner processed by precision die-casting.
- 2. Iron casting pan supports.



- 3. Cartridge cover open button: PUSH(child lock).
- 4. Push & turn dual motion control knob (child lock).
- 5. Magnetic locking system.



6. MULTIPLE SAFETY DEVICE: Multiple safety device installed with Flame Supervision Device, inside with magnetic power unit & thermocouple.

FLAME SUPERVISION DEVICE



THERMOCOUPLE



**MPU
(MAGNETIC
POWER UNIT)**



MULTIPLE SAFETY DEVICE
Two stage Dual Overpressure Protection device fitted with Flame Supervision Device (FSD).

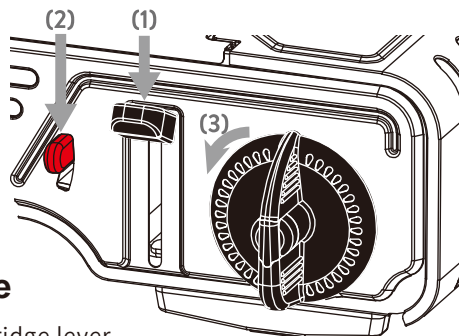

How to ignite

Push down (1) cartridge lever

Hold down (2) the red lever and push & turn the (3) control knob

MSD-5800 BS FSD

Input Rating:	2.2kWx2 (160g/hx2)		
Product Size:	679(L)x286(W)x125(H)mm		
Product Weight:	3.47kg		
Packing Information:	3pcs/ctn (0.099m³/ctn)		

Container Loading Quantity:

20FT	252CTN	756PCS	24.95m³
40FT GP	570CTN	1,710PCS	56.43m³
40FT HQ	670CTN	2,010PCS	66.33m³



MS-2500BS-1FSD

Input Rating:	2.2kW (160g/h)
Product Size:	343(L)×280(W)×118(H)mm
Product Weight:	1.77kg
Packing Information:	4pcs/ctn (0.068m³/ctn)

Container Loading Quantity:

20FT	428CTN	2,568PCS	29.10m³
40FT GP	882CTN	5,292PCS	59.98m³
40FT HQ	1,006CTN	6,036PCS	68.41m³



MS-3800S FSD

Input Rating:	2.75kW (200g/h)
Product Size:	329(L)×277(W)×101(H)mm
Product Weight:	1.75kg
Packing Information:	6pcs/ctn (0.071m³/ctn)

Container Loading Quantity:

20FT	399CTN	2,394PCS	28.33m³
40FT GP	830CTN	4,980PCS	58.93m³
40FT HQ	950CTN	5,700PCS	67.45m³



MS-2800 BS FSD

Input Rating:	2.2kW (160g/h)
Product Size:	372(L)×286(W)×125(H)mm
Product Weight:	1.88kg
Packing Information:	4pcs/ctn (0.07m³/ctn)

Container Loading Quantity:

20FT	419CTN	1,676PCS	29.33m³
40FT GP	867CTN	3,468PCS	60.69m³
40FT HQ	867CTN	3,468PCS	60.69m³

PORTABLE CAMPING STOVE

DOUBLE BURNER

NEW





Built for the wild, ready for every adventure.

The Portable Camping Stove offers precise heat control and easy ignition, so you can cook confidently—anywhere, anytime. Its compact and rugged design ensures reliable performance, whether you’ re deep in the forest or out on the open trail.



Compact for easy storage when closed



Comes with a sturdy wind shield



Includes a regulator valve



Features a portable handle at the bottom

Available in two colours



NEW

NEW



COMPACT CAMPING STOVE

SINGLE BURNER

- Operates with Camping can.
- Ultra-quiet operation
- Stainless steel pan supporter can support various dimensions of cookware.
- (Suitable for pan or pot, the diameter of which is the same as 25cm).



Available in two colours



DUAL-FUEL STOVE



MS-2500LPG

Input Rating:

Gas cartridge - **2.3kW (165g/h)**

28mbar gas cylinder - **2.0kW (145g/h)**

Product Size: **343(L)×280(W)×113(H)mm**

Product Weight: **1.45kg**

Packing Information: **6pcs/ctn (0.068m³/ctn)**

Container Loading Quantity:

20FT **428CTN 2,568PCS 29.10m³**

40FT GP **882CTN 5,292PCS 59.98m³**

40FT HQ **1,006CTN 6,036PCS 68.41m³**

DUAL POWER SOURCE



MS-3800LPG

Input Rating:

Gas cartridge - **2.75kW (200g/h)**

28mbar gas cylinder - **2.0kW (145g/h)**

Product Size: **329(L)×277(W)×101(H)mm**

Product Weight: **1.60kg**

Packing Information: **6pcs/ctn (0.071m³/ctn)**

Container Loading Quantity:

20FT **399CTN 2,394PCS 28.33m³**

40FT GP **830CTN 4,980PCS 58.93m³**

40FT HQ **950CTN 5,700PCS 67.45m³**



Built-in valve / regulator

Inlet port

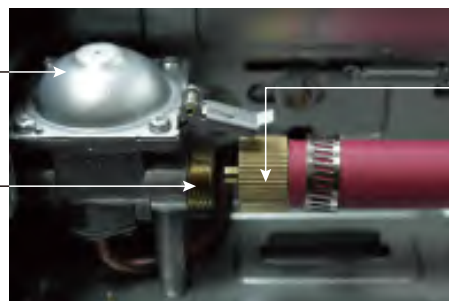

Adaptor (Connections)

- Operates with butane gas cartridge or LP gas cylinder (not included)
- Ultra-quiet operation
- Propane hose & regulator not included

DELUXE ALUMINUM STOVE



NEW

General stove



MS-N7M



MS-N77M



MS-N7M



MS-N77M

NEW

MS-N7M / MS-N77M

Input Rating:	2.5kW (185g/h)		
Product Size:	301(L)×346(W)×86(H)mm		
Product Weight:	1.08kg		
Packing Information:	10pcs/ctn (0.0885m ³ /ctn)		

NEW

Container Loading Quantity:			
20FT	299CTN	2,990PCS	26.46m ³
40FT GP	649CTN	6,490PCS	57.44m ³
40FT HQ	762CTN	7,620PCS	67.44m ³

Round stove



NEW

Magnetic locking system

Easy to connect the gas cartridge the valve safety. Virtually impossible to load the gas cartridge incorrectly.

“ PUSH & TURN ” dual motion safety control knob with auto cartridge ejection safety device.

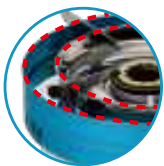

**Round Shape
Double wind-block**



**Brass Burner
3.5kW High Power**

MS-N77R

Input Rating:	3.5kW (253g/h)
Product Size:	330(L)×389(W)×91(H)mm
Product Weight:	1.60kg
Packing Information:	6pcs/ctn

Container Loading Quantity:

20FT	1,944PCS
40FT GP	3,888PCS
40FT HQ	4,884PCS



DELUXE ALUMINUM STOVE

**EXTREMELY HIGH HEAT
11,500BTU/Hr**



MS-7S

Input Rating:	3.5kW (253g/h)
Product Size:	330(L)×389(W)×91(H)mm
Product Weight:	1.45kg
Packing Information:	6pcs/ctn (0.076m³/ctn)

Container Loading Quantity:

20FT	342CTN	2,052PCS	26.00m³
40FT GP	743CTN	4,458PCS	56.47m³
40FT HQ	860CTN	5,160PCS	65.36m³



MS-77

Input Rating:	3.5kW (253g/h)
Product Size:	330(L)×389(W)×91(H)mm
Product Weight:	1.60kg
Packing Information:	6pcs/ctn (0.076m³/ctn)

Container Loading Quantity:

20FT	342CTN	2,052PCS	26.00m³
40FT GP	743CTN	4,458PCS	56.47m³
40FT HQ	860CTN	5,160PCS	65.36m³



MS-7

Input Rating:	3.5kW (253g/h)
Product Size:	330(L)×389(W)×91(H)mm
Product Weight:	1.40kg
Packing Information:	6pcs/ctn (0.076m³/ctn)

Container Loading Quantity:

20FT	342CTN	2,052PCS	26.00m³
40FT GP	743CTN	4,458PCS	56.47m³
40FT HQ	860CTN	5,160PCS	65.36m³



MS-N7 (Magnetic locking system)

Input Rating:	3.5kW (253g/h)
Product Size:	330(L)×389(W)×91(H)mm
Product Weight:	1.30kg
Packing Information:	6pcs/ctn (0.076m³/ctn)

Container Loading Quantity:

20FT	342CTN	2,052PCS	26.00m³
40FT GP	743CTN	4,458PCS	56.47m³
40FT HQ	860CTN	5,160PCS	65.36m³

* OPTIONAL PART

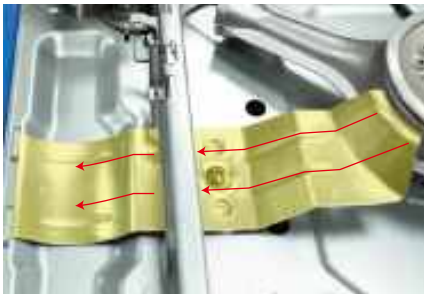

BUILT-IN HEAT TRANSFER PLATE

When you use portable gas appliance, the butane cartridge is getting cold usually because of the heat of vaporization, and the output is decreasing. Heat transfer plate helps to maintain consistent heating power and eliminates left-over butane fuel in cartridge.



MS-808

Input Rating:	2.1kW (150g/h)
Product Size:	245(L)×204(W)×100(H)mm
Product Weight:	1.00kg
Packing Information:	10pcs/ctn (0.08m³/ctn)

Container Loading Quantity:

20FT	320CTN	3,200PCS	25.60m³
40FT GP	704CTN	7,040PCS	56.32m³
40FT HQ	792CTN	7,920PCS	63.36m³

AVAILABLE COLOR



Gold



Silver



Red



Blue

New color scheme



White wood grain



Light wood grain



Yellow wood grain



Deep wood grain

ULTRA MINI STOVE



Espresso

150g gas cartridge is more suitable.

Espresso



Input Rating:	1.9kW (140g/h)		
Product Size:	227(L)×164(W)×125(H)mm		
Product Weight:	0.82kg		
Packing Information:	8pcs/ctn (0.0703m³/ctn)		

Container Loading Quantity:

20FT	358CTN	2,864PCS	25.17m³
40FT GP	756CTN	6,084PCS	53.15m³
40FT HQ	840CTN	6,720PCS	59.05m³



Unique appearance design

“Super Mini” design, portable and compact, has the advantages in both of good-looking and excellent performance.

Magnetic locking system

Easy to make the gas cartridge connect with the valve in safe. It is virtually impossible to load the gas cartridge incorrectly.



Short flame length and optimal combustion with a durable porous burner port.



Magnetic locking system
Easy to make the gas cartridge connect with the valve in safe.



Push and turn dual motion control knob.(Child Lock)



Cute and Mini body to maximize table space and create an elegant table setting.

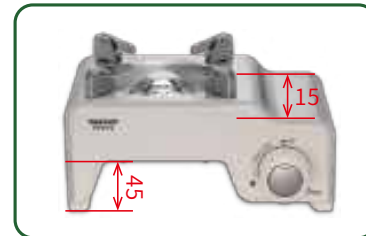

Stepped design to minimize heat transfer and heat load to the gas cartridge.

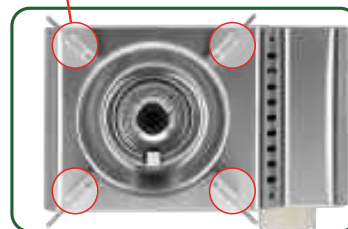

Foldable grate designed to support various dimensions of cookware. (Suitable for pan or pot, the diameter of which is the same as 10cm)



Latte



Input Rating:	2.1kW (150g/h)
Product Size:	265(L)×204(W)×122(H)mm
Product Weight:	1.14kg
Packing Information:	8pcs/ctn (0.083m³/ctn)

Container Loading Quantity:			
20FT	320CTN	2,560PCS	26.56m³
40FT GP	672CTN	5,336PCS	55.78m³
40FT HQ	756CTN	6,048PCS	62.75m³



Latte



Economic inner flame burner processed by precision die-casting



Heightened pan supports



Stainless steel heat shield



Magnetic locking system



Push & turn dual motion control knob (child lock)



Stainless steel heat shield



Solid rubber foot

MINI STOVE



DOUBLE FLAME
MINI STOVE

2 IN 1 BURNER

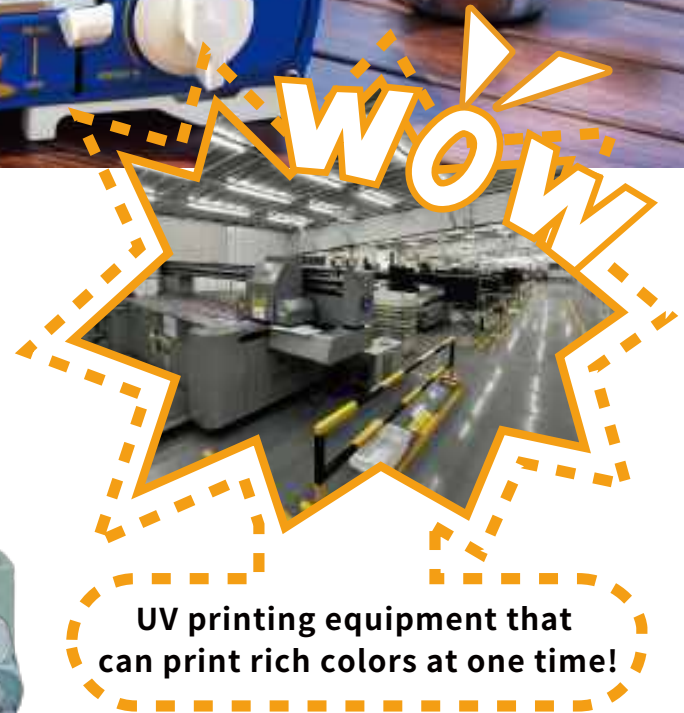

UV printing equipment that
can print rich colors at one time!

MS-8000AS / S / R (801 plastic case)

Input Rating:	2.1kW (150g/h)
Product Size:	245(L)×203(W)×100(H)mm
Product Weight:	1.00kg
Packing Information:	10pcs/ctn (0.077m ³ /ctn)

Container Loading Quantity:

20FT	336CTN	3,360PCS	25.87m ³
40FT GP	740CTN	7,400PCS	56.98m ³
40FT HQ	823CTN	8,230PCS	63.37m ³

MS-8000AS / S / R (802 plastic case)

Input Rating:	2.1kW (150g/h)
Product Size:	245(L)×203(W)×100(H)mm
Product Weight:	1.00kg
Packing Information:	10pcs/ctn (0.07m ³ /ctn)

Container Loading Quantity:

20FT	320CTN	3,200PCS	22.40m ³
40FT GP	754CTN	7,540PCS	52.78m ³
40FT HQ	838CTN	8,380PCS	58.66m ³



MS-8000AS



Stainless steel all over



MS-8000S



MS-8000R

UV printing methods

COMMERCIAL GAS COOKING STOVE

High Power Stove

Portable butane cook stove for Restaurant Use - Certified to U.S. Standards



Safety locking system on cartridge cover



MS-77

Input Rating:	12,000 Btu/Hr
Product Size:	330(L)×389(W)×91(H)mm
Product Weight:	1.60kg
Packing Information:	6pcs/ctn (0.076m³/ctn)

Container Loading Quantity:

20FT	342CTN	2,052PCS	26m³
40FT GP	743CTN	4,458PCS	56.47m³
40FT HQ	860CTN	5,160PCS	65.36m³



MS-3800

Input Rating:	10,000 Btu/Hr
Product Size:	329(L)×277(W)×101(H)mm
Product Weight:	1.50kg
Packing Information:	6pcs/ctn (0.071m³/ctn)

Container Loading Quantity:

20FT	399CTN	2,394PCS	28.33m³
40FT GP	830CTN	4,980PCS	58.93m³
40FT HQ	950CTN	5,700PCS	67.45m³



MS-3800SP

Input Rating:	10,000 Btu/Hr
Product Size:	329(L)×277(W)×101(H)mm
Product Weight:	1.55kg
Packing Information:	6pcs/ctn (0.071m³/ctn)

Container Loading Quantity:

20FT	399CTN	2,394PCS	28.33m³
40FT GP	830CTN	4,980PCS	58.93m³
40FT HQ	950CTN	5,700PCS	67.45m³



MS-2900HC

Input Rating:	15,000 Btu/Hr
Product Size:	372(L)×286(W)×125(H)mm
Product Weight:	1.85kg
Packing Information:	4pcs/ctn (0.07m³/ctn)

Container Loading Quantity:

20FT	419CTN	1,676PCS	29.33m³
40FT GP	867CTN	3,468PCS	60.69m³
40FT HQ	867CTN	3,468PCS	60.69m³

SINGLE BURNER STOVE



Economic Stove

Colorful printing

MS-520

Input Rating:	2.2kW (160g/h)
Product Size:	343(L)×280(W)×113(H)mm
Product Weight:	1.50kg
Packing Information:	6pcs/ctn (0.068m ³ /ctn)

Container Loading Quantity:

20FT	428CTN	2,568PCS	29.10m ³
40FT GP	882CTN	5,292PCS	59.98m ³
40FT HQ	1,006CTN	6,036PCS	68.41m ³



MS-2500

Input Rating:	2.2kW (160g/h)
Product Size:	343(L)×280(W)×113(H)mm
Product Weight:	1.50kg
Packing Information:	6pcs/ctn (0.068m ³ /ctn)

Container Loading Quantity:

20FT	428CTN	2,568PCS	29.10m ³
40FT GP	882CTN	5,292PCS	59.98m ³
40FT HQ	1,006CTN	6,036PCS	68.41m ³



MS-2500BS-1

Input Rating:	2.2kW (160g/h)
Product Size:	343(L)×280(W)×118(H)mm
Product Weight:	1.65kg
Packing Information:	4pcs/ctn (0.0623m ³ /ctn)

Container Loading Quantity:

20FT	462CTN	1,848PCS	28.78m ³
40FT GP	914CTN	3,656PCS	56.94m ³
40FT HQ	1,067CTN	4,268PCS	66.48m ³

SAFETY PLUS STRONG STOVE

MS-2500BS-3E

NEW





- B type cartridge cover to prevent cover opening during usage.

CE

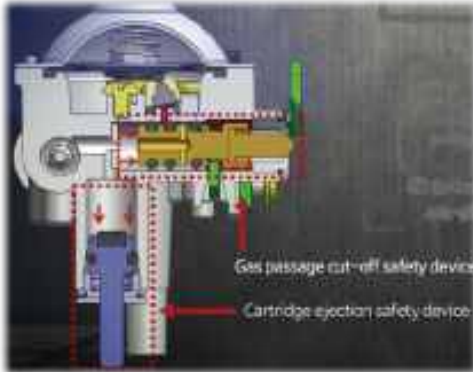

MSR-35 Regulator

Innovation dual overpressure protection system
Built-in 2-stage dual overpressure protection device

- Primary overpressure prevention device: overpressure safety protection device/cartridge ejection safety device
- Secondary overpressure prevention device: gas passage cut-off safety device

How to reset dual overpressure prevention device

1. Turn on the control knob to release the pressure after the overheated gas cartridge is removed.
2. Push the reset lever with the red cap and then switch the control knob to OFF



**Equipped with large round windshield
&
SUS heat block shield.**

1. Preventing the burner flame from being widely spread to the direction of gas cartridge.
2. Minimizing heat loss by blocking wind in outdoor use and keep flame uniformity.
3. Preventing the burner flame from being blown off or extinguished due to external influence.



BSF

Input Rating:	2.2kW (160g/h)		
Product Size:	343(L)×280(W)×113(H)mm		
Product Weight:	1.50kg		
Packing Information:	6pcs/ctn (0.068m³/ctn)		

Container Loading Quantity:			
20FT	428CTN	2,568PCS	29.10m³
40FT GP	882CTN	5,292PCS	59.98m³

The new EU Standard *Safety Brake*

※ Patent number: EP21938979.8

※ The new EU Standard EN 17476:2021

Wrong

Correct



Wrong

For flat portable gas stove, the appliance should not be operable without a pan.

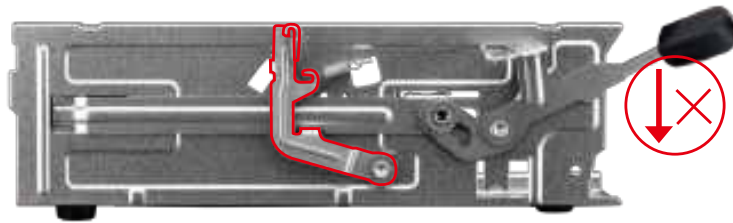

According to this standard, we specially design the safety brake (in below red circle) on the cartridge compartment.

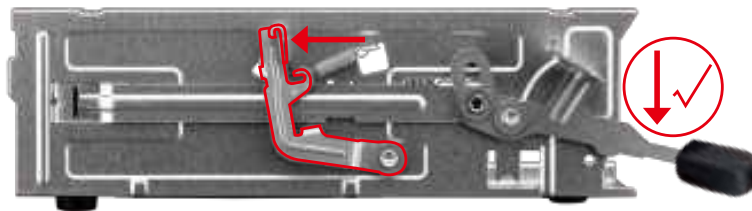

This is to consider the final user's safety to avoid misuse of the stove. If the user doesn't put the drip pan on the top of the stove, and instead the coding vessel directly, then it may cause overheating for gas cartridge and explosion. Therefore, the drip pan must always be placed correctly.

SINGLE BURNER STOVE



HIGH POWER
3.6kW



MS-2900HC

Input Rating:	12,000Btu/hr (265g/h)
Product Size:	372(L)×286(W)×125(H)mm
Product Weight:	1.85kg
Packing Information:	4pcs/ctn (0.07m³/ctn)

Container Loading Quantity:

20FT	419CTN	1,676PCS	29.33m³
40FT GP	867CTN	3,468PCS	60.69m³
40FT HQ	867CTN	3,468PCS	60.69m³



MS-2800 A

Input Rating:	2.2kW (160g/h)
Product Size:	372(L)×286(W)×125(H)mm
Product Weight:	1.80kg
Packing Information:	4pcs/ctn (0.07m³/ctn)

Container Loading Quantity:

20FT	419CTN	1,676PCS	29.33m³
40FT GP	867CTN	3,468PCS	60.69m³
40FT HQ	867CTN	3,468PCS	60.69m³



MS-2800 BS

Input Rating:	2.2kW (160g/h)
Product Size:	372(L)×286(W)×125(H)mm
Product Weight:	1.80kg
Packing Information:	4pcs/ctn (0.07m³/ctn)

Container Loading Quantity:

20FT	419CTN	1,676PCS	29.33m³
40FT GP	867CTN	3,468PCS	60.69m³
40FT HQ	867CTN	3,468PCS	60.69m³

SINGLE BURNER STOVE



MS-3500

Input Rating:	2.75kW (200g/h)
Product Size:	326(L)×277(W)×91(H)mm
Product Weight:	1.50kg
Packing Information:	6pcs/ctn (0.064m³/ctn)

Container Loading Quantity:

20FT	450CTN	2,700PCS	28.80m³
40FT GP	924CTN	5,544PCS	59.14m³
40FT HQ	1,062CTN	6,372PCS	67.97m³



MS-3500S

Input Rating:	2.75kW (200g/h)
Product Size:	326(L)×277(W)×91(H)mm
Product Weight:	1.60kg
Packing Information:	6pcs/ctn (0.064m³/ctn)

Container Loading Quantity:

20FT	450CTN	2,700PCS	28.80m³
40FT GP	924CTN	5,544PCS	59.14m³
40FT HQ	1,062CTN	6,372PCS	67.97m³



MS-3900DFW

Input Rating:	4.2kW (305g/h)
Product Size:	329(L)×277(W)×114(H)mm
Product Weight:	1.60kg
Packing Information:	6pcs/ctn (0.078m³/ctn)

Container Loading Quantity:

20FT	347CTN	2,082PCS	27.10m³
40FT GP	749CTN	4,494PCS	58.42m³
40FT HQ	859CTN	5,154PCS	67.01m³

SINGLE BURNER STOVE



MS-3800

Input Rating:	2.75kW (200g/h)
Product Size:	329(L)×277(W)×101(H)mm
Product Weight:	1.50kg
Packing Information:	6pcs/ctn (0.071m³/ctn)

Container Loading Quantity:

20FT	399CTN	2,394PCS	28.33m³
40FT GP	830CTN	4,980PCS	58.93m³
40FT HQ	950CTN	5,700PCS	67.45m³



MS-3800SP

Input Rating:	2.75kW (200g/h)
Product Size:	329(L)×277(W)×101(H)mm
Product Weight:	1.55kg
Packing Information:	6pcs/ctn (0.071m³/ctn)

Container Loading Quantity:

20FT	399CTN	2,394PCS	28.33m³
40FT GP	830CTN	4,980PCS	58.93m³
40FT HQ	950CTN	5,700PCS	67.45m³



MS-3800DFS

Input Rating:	3.1kW (225g/h)
Product Size:	329(L)×277(W)×101(H)mm
Product Weight:	1.70kg
Packing Information:	6pcs/ctn (0.071m³/ctn)

Container Loading Quantity:

20FT	399CTN	2,394PCS	28.33m³
40FT GP	830CTN	4,980PCS	58.93m³
40FT HQ	950CTN	5,700PCS	67.45m³

SINGLE BURNER STOVE



MS-7000

Input Rating:	1.8kW (130g/h)
Product Size:	303(L)×249(W)×95(H)mm
Product Weight:	1.25kg
Packing Information:	6pcs/ctn (0.054m³/ctn)

Container Loading Quantity:

20FT	518CTN	3,108PCS	27.97m³
40FT GP	1070CTN	6,420PCS	57.78m³
40FT HQ	1236CTN	7,416PCS	66.74m³



MS-7000S

Input Rating:	1.8kW (130g/h)
Product Size:	303(L)×249(W)×95(H)mm
Product Weight:	1.25kg
Packing Information:	6pcs/ctn (0.054m³/ctn)

Container Loading Quantity:

20FT	518CTN	3,108PCS	27.97m³
40FT GP	1070CTN	6,420PCS	57.78m³
40FT HQ	1236CTN	7,416PCS	66.74m³



2 IN 1 BURNER



MS-7000DFS

Input Rating:	2.2kW (160g/h)
Product Size:	303(L)×249(W)×95(H)mm
Product Weight:	1.28kg
Packing Information:	6pcs/ctn (0.054m³/ctn)

Container Loading Quantity:

20FT	518CTN	3,108PCS	27.97m³
40FT GP	1070CTN	6,420PCS	57.78m³
40FT HQ	1236CTN	7,416PCS	66.74m³



Brass Burner



MS-2900HCBW

Input Rating:	4.5kW (330g/h)
Product Size:	372(L)×285(W)×132(H)mm
Product Weight:	2.10kg
Packing Information:	4pcs/ctn (0.073m³/ctn)

Container Loading Quantity:

20FT	381CTN	1,524PCS	27.81m³
40FT GP	791CTN	3,164PCS	57.74m³
40FT HQ	910CTN	3,640PCS	66.43m³

DOUBLE ESPRESSO BI FLAME PRO

NEW



MSD-N5000S-E

- Push and turn dual motion control knob.(Child Lock)
- Stainless steel drip pan & pan supporter.
- Magnetic locking system. Easy to make the gas cartridge connect with the valve in safe. It is virtually impossible to load the gas cartridge incorrectly.
- Unique design, it has the advantages of both good-looking and excellent performance.
- Short flame length and optimal combustion with a durable porous burner port.



TWO OPTIONS FOR COOKWARE

WIDE GRILL STOVE



* OPTIONAL PART

WIDE COOKING PLATE

3-Layered non-stick

coated griddle with

grease collection reservoir.

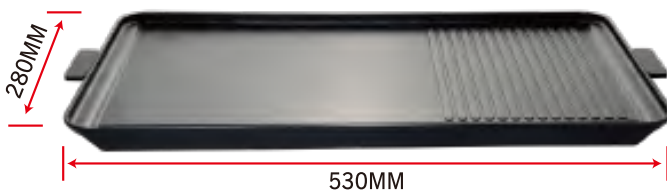

MSD-5800BS

Input Rating: **2.2kWx2 (160g/hx2)**

Product Size: **679(L)x286(W)x125(H)mm**

Product Weight: **3.20kg**

Packing Information: **3pcs/ctn (0.099m³/ctn)**

Container Loading Quantity:

20FT **252CTN 756PCS 24.95m³**

40FT GP **570CTN 1,710PCS 56.43m³**

40FT HQ **670CTN 2,010PCS 66.33m³**



WIDE STOVE



MSD-5800S

Input Rating:	2.2kWx2 (160g/hx2)		
Product Size:	679(L)x286(W)x125(H)mm		
Product Weight:	3.30kg		
Packing Information:	3pcs/ctn (0.099m³/ctn)		

Container Loading Quantity:

20FT	252CTN	756PCS	24.95m³
40FT GP	570CTN	1,710PCS	56.43m³
40FT HQ	670CTN	2,010PCS	66.33m³

CARRY CASE



INFRARED STOVE



MS-3500CS

Input Rating:	1.65kW (120g/h)
Product Size:	336(L)×277(W)×91(H)mm
Product Weight:	1.60kg
Packing Information:	6pcs/ctn (0.064m³/ctn)

Container Loading Quantity:			
20FT	450CTN	2,700PCS	28.80m³
40FT GP	924CTN	5,544PCS	59.14m³
40FT HQ	1,062CTN	6,372PCS	67.97m³



MS-N3600CR

Input Rating:	1.65kW (120g/h)
Product Size:	325(L)×277(W)×93(H)mm
Product Weight:	1.55kg
Packing Information:	6pcs/ctn (0.066m³/ctn)

Container Loading Quantity:			
20FT	395CTN	2,370PCS	26.07m³
40FT GP	834CTN	5,004PCS	55.04m³
40FT HQ	984CTN	5,904PCS	64.94m³



INFRARED STOVE



1. MINI INFRARED STOVE 2. Stainless steel all over

MS-8000ASC (802 plastic case)

Input Rating:	1.65kW (120g/h)
Product Size:	245(L)×203(W)×100(H)mm
Product Weight:	1.05kg
Packing Information:	10pcs/ctn (0.07m³/ctn)

Container Loading Quantity:

20FT	336CTN	3,360PCS	23.52m³
40FT GP	740CTN	7,400PCS	51.80m³
40FT HQ	823CTN	8,230PCS	57.61m³

MS-2500BS-1C

Input Rating:	1.65kW (120g/h)
Product Size:	343(L)×280(W)×118(H)mm
Product Weight:	1.80kg
Packing Information:	4pcs/ctn (0.0623m³/ctn)

Container Loading Quantity:

20FT	462CTN	1,848PCS	28.78m³
40FT GP	914CTN	3,656PCS	56.94m³
40FT HQ	1067CTN	4,268PCS	66.48m³



UK
CA



MS-2500C

Input Rating:	1.65kW (120g/h)
Product Size:	343(L)×280(W)×118(H)mm
Product Weight:	1.55kg
Packing Information:	6pcs/ctn (0.086m³/ctn)

Container Loading Quantity:

20FT	335CTN	2,010PCS	
40FT GP	672CTN	4,032PCS	28.81m³
40FT HQ	766CTN	4,596PCS	57.79m³
			65.88m³



CERAMIC SURFACE COMBUSTION

Stable Flame - shorter and closer to ceramic cellular burner head.

Infrared prevents flare-up and spillover.

FAR INFRARED RADIATION

Infrared eliminates hot spots.

Healthy heat.

PILOT IGNITION

PROPER STOVE



MAGNETIC LOCKING SYSTEM



MS-N6000RP

Input Rating:	2.2kW (160g/h)
Product Size:	301(L)×241(W)×95(H)mm
Product Weight:	1.23kg
Packing Information:	6pcs/ctn (0.057m³/ctn)

Container Loading Quantity:

20FT	500CTN	3,000PCS	28.50m³
40FT GP	1019CTN	6,114PCS	58.08m³
40FT HQ	1184CTN	7,104PCS	67.49m³



DOUBLE FLAME STOVE



 Stainless steel all over



 Stainless steel drip pan & cover



MS-N6000AS

Input Rating:	2.2kW (160g/h)
Product Size:	301(L)×241(W)×95(H)mm
Product Weight:	1.23kg
Packing Information:	6pcs/ctn (0.057m³/ctn)

Container Loading Quantity:

20FT	500CTN	3,000PCS	28.50m³
40FT GP	1019CTN	6,114PCS	58.08m³
40FT HQ	1184CTN	7,104PCS	67.49m³

MS-N6000S

Input Rating:	2.2kW (160g/h)
Product Size:	301(L)×241(W)×95(H)mm
Product Weight:	1.26kg
Packing Information:	6pcs/ctn (0.057m³/ctn)

Container Loading Quantity:

20FT	500CTN	3,000PCS	28.50m³
40FT GP	1019CTN	6,114PCS	58.08m³
40FT HQ	1184CTN	7,104PCS	67.49m³

MS-N6000R

Input Rating:	2.2kW (160g/h)
Product Size:	301(L)×241(W)×95(H)mm
Product Weight:	1.27kg
Packing Information:	6pcs/ctn (0.057m³/ctn)

Container Loading Quantity:

20FT	500CTN	3,000PCS	28.50m³
40FT GP	1019CTN	6,114PCS	58.08m³
40FT HQ	1184CTN	7,104PCS	67.49m³

MS-N3900HCB

Input Rating:	4.2kW (305g/h)
Product Size:	329(L)×277(W)×109(H)mm
Product Weight:	1.84kg
Packing Information:	6pcs/ctn (0.078m³/ctn)

Container Loading Quantity:

20FT	347CTN	2,082PCS	27.10m³
40FT GP	749CTN	4,494PCS	58.42m³
40FT HQ	859CTN	5,154PCS	67.01m³

NEW

FIVE ATOMIC STOVE



Magnetic locking system

Easy to make the gas cartridge connect with the valve in safe. It is virtually impossible to load the gas cartridge incorrectly.



“PUSH & TURN” dual motion safety control knob with auto cartridge ejection safety device.



Overpressure safety device (as below picture).

The gas cartridge will be ejected automatically from the stove if inside pressure is too high.



Unique appearance design 5 in 1 burner



SPENDOUR STOVE



MS-N3600AS

Input Rating:	2.75kW (200g/h)
Product Size:	325(L)×277(W)×93(H)mm
Product Weight:	1.44kg
Packing Information:	6pcs/ctn (0.066m³/ctn)

Container Loading Quantity:

20FT	395CTN	2,370PCS	26.07m³
40FT GP	834CTN	5,004PCS	55.04m³
40FT HQ	984CTN	5,904PCS	64.94m³



MS-N3600S

Input Rating:	2.75kW (200g/h)
Product Size:	325(L)×277(W)×93(H)mm
Product Weight:	1.47kg
Packing Information:	6pcs/ctn (0.066m³/ctn)

Container Loading Quantity:

20FT	395CTN	2,370PCS	26.07m³
40FT GP	834CTN	5,004PCS	55.04m³
40FT HQ	984CTN	5,904PCS	64.94m³



MS-N3600R

Input Rating:	2.75kW (200g/h)
Product Size:	325(L)×277(W)×93(H)mm
Product Weight:	1.40kg
Packing Information:	6pcs/ctn (0.066m³/ctn)

Container Loading Quantity:

20FT	395CTN	2,370PCS	26.07m³
40FT GP	834CTN	5,004PCS	55.04m³
40FT HQ	984CTN	5,904PCS	64.94m³



BBQ STOVE



MS-8 BBQ

MS-8 BBQ

Input Rating:	2.1kW (150g/h)
Product Size:	460(L)×335(W)×168(H)mm
Product Weight:	4.60kg
Packing Information:	3pcs/ctn (0.074m³/ctn)
Pot size:	374(L)×301(W)×48(H)mm

Container Loading Quantity:			
20FT	336CTN	1,008PCS	24.86m³
40FT GP	770CTN	2,310PCS	56.98m³
40FT HQ	900CTN	2,700PCS	66.60m³



MS-8 mini BBQ OS

Input Rating:	1.78kW (130g/h)
Product Size:	426(L)×291(W)×118(H)mm
Product Weight:	3.63kg
Packing Information:	2pcs/ctn (0.045m³/ctn)

Container Loading Quantity:			
20FT	600CTN	1,200PCS	27m³
40FT GP	1277CTN	2,554PCS	57.50m³
40FT HQ	1500CTN	3,000PCS	67.50m³



MS-8 mini BBQ (CSA)

Input Rating:	2.1kW (155g/h)
Product Size:	426(L)×291(W)×118(H)mm
Product Weight:	3.79kg
Packing Information:	2pcs/ctn (0.041m³/ctn)

Container Loading Quantity:			
20FT	683CTN	1,366PCS	28m³
40FT GP	1414CTN	2,828PCS	57.98m³
40FT HQ	1658CTN	3,316PCS	67.98m³

DEEP DISH GRILL PAN STOVE



MS-8

Input Rating:	2.1kW (150g/h)
Product Size:	460(L)×335(W)×168(H)mm
Product Weight:	4.60kg
Packing Information:	3pcs/ctn (0.074m³/ctn)
Pot size:	374(L)×301(W)×48(H)mm

Container Loading Quantity:

20FT	336CTN	1,008PCS	24.86m³
40FT GP	770CTN	2,310PCS	56.98m³
40FT HQ	900CTN	2,700PCS	66.60m³



MS-8 mini (CE)

Input Rating:	2.1kW (150g/h)
Product Size:	414(L)×291(W)×132(H)mm
Product Weight:	4.00kg
Packing Information:	3pcs/ctn (0.067m³/ctn)
Pot size:	332(L)×268(W)×68(H)mm

Container Loading Quantity:

20FT	390CTN	1,170PCS	26.13m³
40FT GP	810CTN	2,430PCS	54.27m³
40FT HQ	992CTN	2,976PCS	66.46m³

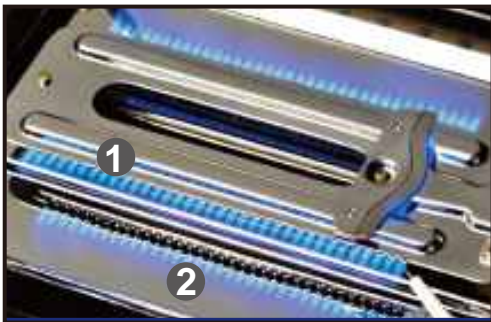

1 STAINLESS STEEL WIDE BURNER

70 burner holes can ensure high heat efficiency and flame stability.

2 Stainless steel heat reflection plate

3 Removal drip pan tray



4

PUSH

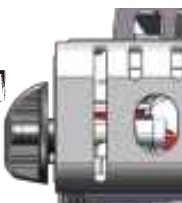

4 " PUSH & TURN " dual motion safety control knob

CAMPING KIT



Lid with folding handle

323 x 259 x 65 mm



Pancake grill pan

281 x 208 x 33 mm



Tokoyaki grill pan

260 x 210 x 38 mm



Steamer

295 x 230 x 6.5 mm



Cooking pot

332 x 268 x 68 mm



- 1 Kitchen tongs 2 Clip for steamer plate 3 Multi-functional scissors 4 Sticks for Balls 5 Brush
- 6 Cutting Board 7 Organizer Bag



FUN COOK KIT

Input Rating:	2.1kW (155g/h)
Product Size:	430(L)×300(W)×230(H)mm
Product Weight:	7.55kg
Packing Information:	1pcs/ctn (0.053m³/ctn)

Container Loading Quantity:		
20FT	462PCS	24.49m³
40FT GP	1,070PCS	56.71m³
40FT HQ	1,254PCS	66.46m³



MS-8000PLUS

- ❶ Full transparent plastic case
- ❷ 3-layered non-stick grill pan
- ❸ Multi-functional scissors
- ❹ Kitchen tongs
- ❺ Mini stove MS-8000



MS-8 SW KIT

- ❶ Bag
- ❷ Stainless steel lid
- ❸ 3-layered non-stick pot
- ❹ BBQ stove



MS-8 mini BBQ OS KIT

- ❶ Bag
- ❷ Stainless steel lid
- ❸ 3-layered non-stick pot
- ❹ BBQ stove



MSD-5800S COMBO

- ① Tempered glass lid
- ② 3-layered non-stick grill pan
- ③ Non-stick grill plate
- ④ Spatula
- ⑤ Multi-functional scissors
- ⑥ Kitchen tongs
- ⑦ Ladle
- ⑧ COMBO stove



MEGA KIT

- ① Tempered glass lid
- ② 3-layered non-stick grill pan
- ③ Non-stick grill plate
- ④ Spatula
- ⑤ Multi-functional scissors
- ⑥ Kitchen tongs
- ⑦ Ladle
- ⑧ Gas cartridge sold separately
- ⑨ Portable gas stove MS-2900 or MS-2800



MS-2500 KIT **NEW**

- ① Portable gas stove MS-2500
- ② Non-stick grill plate

FOLDABLE STOVE



MS-100

Input Rating:	2.2kW (160g/h)
Product Size:	319(L)×128(W)×113(H)mm
Product Weight:	1.80kg
Packing Information:	6pcs/ctn (0.039m³/ctn)

Container Loading Quantity:

20FT	687CTN	4,122PCS	26.79m³
40FT GP	1,450CTN	8,700PCS	56.55m³
40FT HQ	1,700CTN	10,200PCS	66.30m³

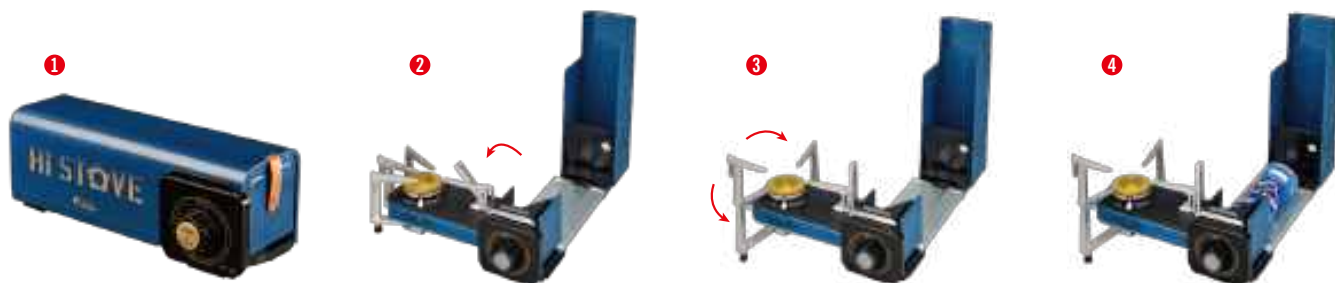



CE

MS-200JS NEW

Input Rating:	2.4kW (175g/h)		
Product Size:	305(L)×226(W)×120(H)mm		
Product Weight:	2.20kg		
Packing Information:	5pcs/ctn (0.056m³/ctn)		

Container Loading Quantity:			
20FT	472CTN	2,360PCS	26.43m³
40FT GP	984CTN	4,920PCS	55.11m³
40FT HQ	1,169CTN	5,845PCS	65.46m³

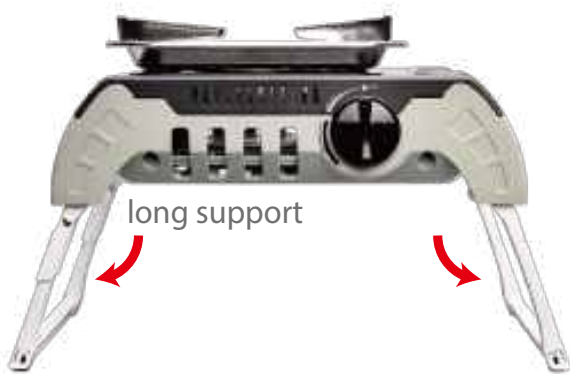

This appliance can be used with MSF-2, MSF-3 or MSF-7 cartridge.



This appliance has short supports, which shall only be used with the MAX MSF-3 butane-propane mixture cartridge.



MS-220JS NEW

Input Rating:	2.4kW (175g/h)		
Product Size:	305(L)×226(W)×120(H)mm		
Product Weight:	2.20kg		
Packing Information:	5pcs/ctn (0.056m³/ctn)		

Container Loading Quantity:			
20FT	472CTN	2,360PCS	26.43m³
40FT GP	984CTN	4,920PCS	55.11m³
40FT HQ	1,169CTN	5,845PCS	65.46m³

CAMPING GAS CARTRIDGE



■ Camping Gas Cartridge

	MSF-2	MSF-3	MSF-7	No. of units per container type						
	MSF-4(EU)	MSF-8(EU)	MSF-9(EU)	Model	20FT		40FT		40FT HC	
Fuel Capacity	100g (110g)	230g	450g							
Capacity	321ml	509ml	990ml		Unit	Box	Unit	Box	Unit	Box
Packing	24pcs (3x4x2)	24pcs (3x4x2)	12pcs (3x4)	MSF-2 / MSF-4(EU)	31,992	1,333	63,984	2,666	84,552	3,523
	450x340x135mm	450x340x170mm	450x340x170mm	MSF-3 / MSF-8(EU)	25,824	1,076	51,672	2,153	56,880	2,370
Features	Compatible with screw connector type camping devices			MSF-7 / MSF-9(EU)	12,912	1,076	25,836	2,153	28,440	2,370



BUTANE GAS CARTRIDGE



■ Butane Gas Cartridge



MINI-CRV

Fuel Capacity	150g	
Capacity	357ml	
Packing	Inner packing	60pcs/box
	Outer Box	441x374x315mm (0.052CBM)

Classify	No. of units per container type					
	20FT		40FT		40FT HC	
	Unit	Box	Unit	Box	Unit	Box
150g	31,200	520	63,000	1,050	73,800	1,230

MSF-1A, MSF-1 CRV

Fuel Capacity	220g, 227g	
Capacity	420ml	
Packing	Inner Packing	4pcs / Shrink Film (4x1)
	Outer Box	28pcs (4x7) 485x280x210mm

Item	Packing Information		No. of units per container type					
	Outer Box		20FT		40FT		40FT HC	
	L x W x H	CBM	Unit	Box	Unit	Box	Unit	Box
Butane Gas	485x280x210mm	0.028	28,224	1,008	57,400	2,050	65,184	2,328

■ Max CRV Butane Gas Cartridge



CRV with Triple Seaming

- Benefit of Triple Seaming

Triple Seaming technology can prevent rupture and explosion by holding the top and body plate together until the CRV system activates and all residual gas are continuously discharged with 12 release vents.



Normal

Butane Gas Cartridge



Dot-Shaped

Explosion - ProofVent



Max CRV

Butane Cartridge

Dot-Shaped Explosion - ProofVent



Explosion-Proof **CRV** System

(Invention Patent No.10-0572517)



- **What is CRV? (Countersink Release Vent)**

When excessive pressure is supplied into the butane gas cartridge, CRV system releases gas from dot-shaped explosion proof vents in the countersink at the top of the can.

- **The world wide use in over 65 countries of the world.**

- **Max CRV does not leave the butane residual even in wintertime.**

You can save energy cost since Max CRV compounded with the high quality liquied gas, helps a complete combustion in stove and keeps a steady strong heat power until the cartridge is completely empty.

- **Max CRV Butane Gas Cartridge, Your only choice for high product quality, user safety and energy saving.**

Explosion-proof, CRV system is very popular with all over the world as well as domestic market.

- UL Listed in U.S.A and Canada.
- CE approved.

CAMPING LANTERN





Specification

1. Item: Camping Lantern
2. Model: MS-90H
3. Material: Glass
4. Size: 64*64*90mm
5. Weight: 60g
6. Gas consumption: 10g/h
7. Type of gas: Screw type butane propane mix(110g, 230g,450g)
8. Ignition type: By manual



Specification

1. Item: Camping Lantern
2. Model: MS-140H
3. Material: Glass
4. Size: 85*85*110mm
5. Weight: 120g
6. Gas consumption: 10g/h
7. Type of gas: Screw type butane propane mix(110g, 230g,450g)
8. Ignition type: By manual

Camping Lanterns are a versatile outdoor lighting solution that combines practicality with decorative appeal. Utilizing real flame combustion, they create a warm and dynamic play of light and shadow, offering an enchanting visual experience. Unlike traditional electric lights, these lamps operate without electrical connections, ensuring flexible and hassle-free installation—perfect for outdoor spaces like courtyards, patios, and gardens where fixed power sources may be unavailable. The naturally flickering flames add a touch of romance, transforming any area into an immersive, ambient retreat.



GAS TORCH

FREE



New upgrade, with base stand, more stable.



LONG... GAS TORCH



MS-T5L **NEW**

- Input Rating: **1.3kW (95g/h)**
- Product Size: **184(L)x70(W)x50(H)mm**
- Product Weight: **0.17kg**
- Packing Information: **10pcs/ctn**



GAS TORCH

▪ Anti Flare Function ▪

The phenomenon of flaring may occur because of the spout of liquid gas during the warm up period or if the gas torch is moved.



- Automatic piezo ignition
- One touch gas connection
- Focused high fire power more than 1300°C
- Adjustable fire power range
- Flame-retardant housing
- Installed on the base: more stable for display
- Longer flame pipe: safer for burning charcoal & baking
- Plastic case: easy to carry & convenient for storage



MS-T7L **NEW**
LONG... GAS TORCH



MS-T6 **NEW**



MS-T2



MS-T3



MS-T3 **CE** 

Input Rating:	1.3kW (95g/h)
Product Size:	178(L)×70(W)×50(H)mm
Product Weight:	0.15kg
Packing Information:	10pcs/ctn

MS-T5

Input Rating:	1.3kW (95g/h)
Product Size:	179(L)×70(W)×50(H)mm
Product Weight:	0.14kg



MS-T5

ACCESSORIES

Hot Pot G-13

Dimension: 308 x 258 x 150 mm

Volume: 3.5L

Product weight: 1.65kg

Individual packing: Color box

Packing information: 8pcs/ctn



Bayonet type locking system to fix POT on pan supports.

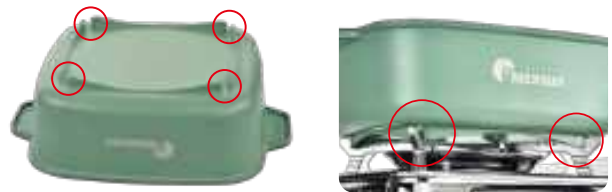

PFOA - free

3 LAYERED NON-STICK POT AND GRILL PLATE

Made of aluminum alloy die castings

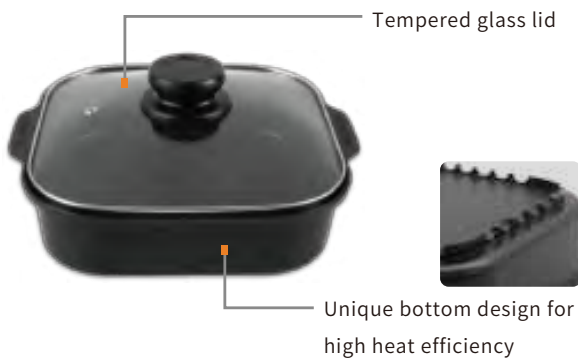
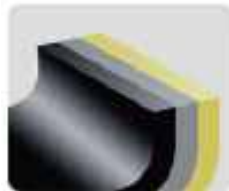

MG-8000

Dimension: 240 x 213 x 64 mm

Product weight: 1.05kg

Individual packing: Color box

Packing information: 10pcs/ctn

AVAILABLE COLOR



MG-2900

Dimension: 274 x 246 x 73 mm

Product weight: 1.45kg

Individual packing: Color box

Packing information: 10pcs/ctn

ACCESSORIES

MG-102

Dimension: 320 x 320 mm

Volume:

Product weight: 1.18kg

Individual packing: Color box

Packing information: 10pcs/ctn

Stew&Grill Multi Use
4Layered Non-Stick Coating

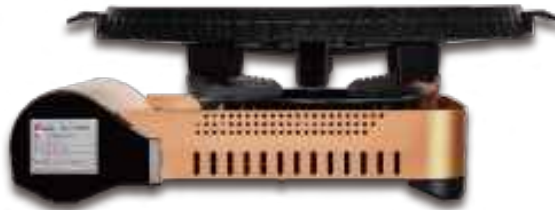
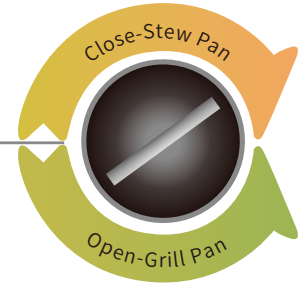

MG-2800

Dimension: 255 x 224 x 22 mm

Product weight: 0.50kg

Individual packing: Color box

Packing information: 10pcs/ctn



WINDSHIELD

Dimension: 840 x 240 mm

Product weight: 0.25kg

Individual packing: Nylon bag

Packing information: 50pcs/ctn



ACCESSORIES



WINDSHIELD NEW

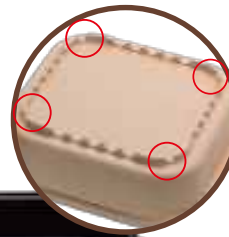

Sturdy bottom bayonet mount.
Patent number:
CN206817559U
201720719530.0

MG-240 COMBO

Dimension: 240 x 213 x 92 mm
 Product weight: 1.05kg
 Individual packing: Color box
 Packing information: 10pcs/ctn



PFOA - free
3 LAYERED NON-STICK
POT AND GRILL PLATE

Made of aluminum alloy die castings



CUTLERY KIT

Dimension: 221 x 101 x 30 mm
 Product weight: 0.36kg
 Packing information: 50sets/ctn



- 1 Multi-functional scissors
- 2 Kitchen tongs
- 3 Fork
- 4 Spoon
- 5 Brush

Mini stove



MINI B
P.13-14

NEW



MINI A
P.15-16



MS-03
P.07

NEW



MS-8000AS
P.17



MS-8000S
P.17



MS-8000R
P.17



MS-808
P.12

Single burner stove



MS-520/2500
P.19



BSF
P.22



MS-2500BS-1
P.19



MS-2500BS-1 FSD
P.04



MS-3500
P.24



MS-3500S
P.24



MS-3800
P.25



MS-3800SP
P.25



MS-2800 A
P.23



MS-2800 BS
P.23



MS-2800 BS FSD
P.04



MS-2900HC
P.23



MS-2900HCBW
P.26



MS-3800DFS
P.25



MS-3800S FSD
P.04



MS-3900DFW
P.24



MS-7000
P.26



MS-7000S
P.26



MS-7000DFS
P.26



MS-7S
P.11



MS-77
P.11



MS-7
P.11



MS-2500BS-3E
P.20-21

NEW



MS-200JS
P.42

NEW



MS-220JS
P.42

NEW

Double burner stove



NEW

MSD-N5000S-E
P.27



MSD-5800S
P.29



MSD-5800BS
P.28 **NEW**



MSD-5800BS FSD
P.03 **NEW**



GAS ONE 02
P.05-06 **NEW**

COMMERCIAL GAS COOKING STOVE



MS-77
P.18



MS-3800
P.18



MS-3800SP
P.18



MS-2900HC
P.18

Ceramic burner stove



MS-8000ASC
P.31



MS-2500BS-1C
P.31



MS-2500C
P.31



MS-3500CS
P.30



MS-N3600CR
P.30

BBQ stove & Grill pan stove



MS-8 mini BBQ
P.36



MS-8 mini BBQ OS
P.36



MS-8 BBQ
P.36



MS-8 mini
P.37



MS-8
P.37

Magnetic stove



MS-N3600AS
P.35



MS-N3600S
P.35



MS-N3600R
P.35



MS-N3600B5
P.34



MS-N6000AS
P.33



MS-N6000S
P.33



MS-N6000R
P.33



MS-100
P.41



MS-N6000RP
P.32



MS-N77R
P.10 **NEW**



MS-N3900HCB
P.33



MS-N7M
P.09 **NEW**



MS-N77M
P.09 **NEW**



MS-N7
P.12



INDOOR STOVE
P.01-02

NEW

MAXSUN (DALIAN) CO . , LTD.

No. 125, Bayiroad, Jinzhou district, Dalian, 116100, China

Tel. +86 411 87858555~7

Fax. +86 411 8785 8558

Email: sales@maxsun-china.com

www.maxsun-china.com

Copyright©2024 Maxsun (Dalian) Co., Ltd. All Rights Reserved.



HOMEPAGE

<http://www.maxsun-china.com>



FACEBOOK

<http://www.maxsunchina>



TWITTER

http://www.maxsun_china



INSTAGRAM

<http://www.maxsunchina>

